

REVISION RECORD				
REV	ECN	DESCRIPTION	DRFT	DATE
A0		NEW		21.06.30

NOTES1:

UL Standard

- 1.Rated voltage/current : 300V / 10A
- 2.Withstanding voltage : AC1600V/1Min.
- 3.Wire range : 24~16AWG

IEC Standard

1. Pollution degree	2	2	3
Overvoltage category	II	III	III
Rate impulse voltage(KV)	2.5KV	2.5KV	2.5KV
Rate voltage(V)	400V	200V	160V
Rate current(A)	17.5A		

2.Wire range : 0.2~1.5mm²

NOTES2:

- 1.Dimension shall be interpreted per ASME Y14.5-2009
- 2.Pitch : 3.50mm, Poles : N=01~24P
- 3.Stripping length : 10mm
- 4.Operating temperature:-40°C~+105°C
- 5.Undimensioned tolerances:

Pitch range in mm			Nominal dimension range in mm					-	∩	□
To	Over To	Over To	To	Over To	Over To	Over To	Over To	0.1/10		
6	10	24	30	30	60	100	150	<		
±0.15	±0.20	±0.30	±0.30	±0.50	±0.70	±1.00	±1.30	±2'		

6.RoHS Compliance

Ordering Information

JL271R - 350 XX G 0 1

- Pitch 350=3.5PH
- No.of pins 1P~24P
- Housing Color
B=Black
G=Green
U=Blue
R=Red
W=White
Y=Yellow
□=Orange
E=Grey
- Packing

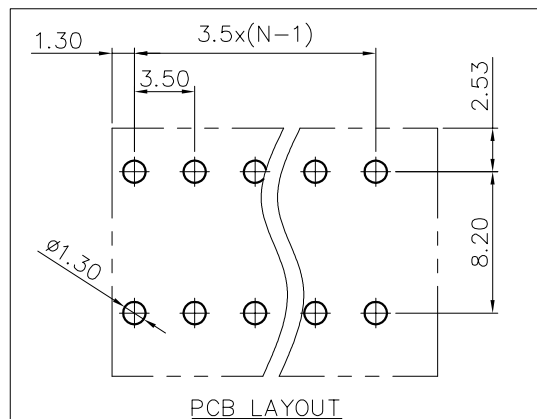
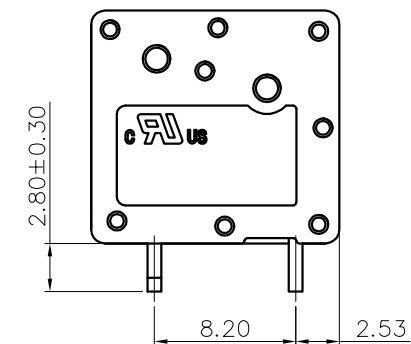
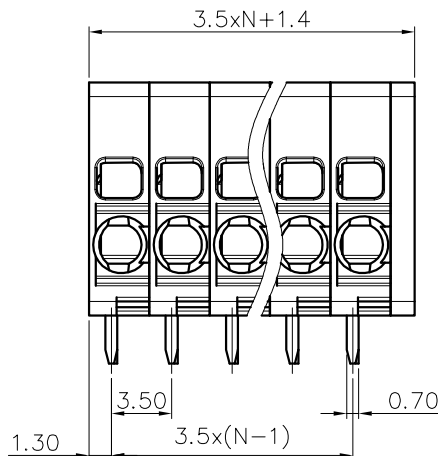
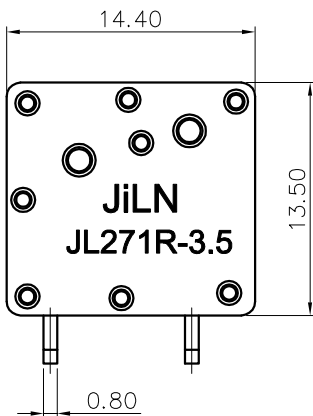

DRAW	SHUANGPING ZHENG	SCALE	FIT	东莞市锦凌电子有限公司 DONGGUAN JINLING ELECTRONIC CO.,LTD	
		UNIT	mm		
CHECK	LICHAD LIU	SIZE	A4		
		SHEET	1/1		
APPROVE	YONGLIANG GAO	PROJ.		PART NO.	JL271R-350XXG01
				TITLE:	JL271R-3.5-XXP弹簧式/弯脚/双排/绿色