

SE3415

P-Channel Enhancement-Mode MOSFET

Revision: A

General Description

Advanced trench technology to provide excellent RDS(ON), low gate charge and low operation voltage. This device is suitable for using as a load switch or in PWM applications.

- Simple Drive Requirement
- Small Package Outline
- Surface Mount Device

Features

For a single MOSFET

- $V_{DS} = -15V$
- $R_{DS(ON)} = 33m\Omega @ V_{GS}=-4.5 @ I_{DS}=-4A$

Pin configurations

See Diagram below

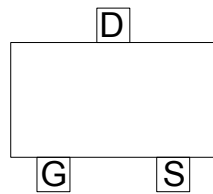

SOT-23

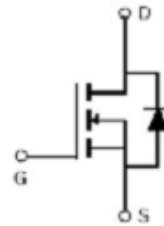

Absolute Maximum Ratings

Parameter		Symbol	Rating	Units
Drain-Source Voltage		V_{DS}	-15	V
Gate-Source Voltage		V_{GS}	± 8	V
Drain Current	Continuous	I_D	-4	A
	Pulsed		-30	
Total Power Dissipation	@TA=25°C	P_D	1.5	W
Operating Junction Temperature Range		T_J	-55 to 150	°C

SE3415

Electrical Characteristics (T _J =25°C unless otherwise noted)						
Symbol	Parameter	Test Conditions	Min	Typ	Max	Units
OFF CHARACTERISTICS (Note 2)						
BV _{DSS}	Drain-Source Breakdown Voltage	I _D =-250μA, V _{GS} =0 V	-15			V
I _{DSS}	Drain to Source Leakage Current	V _{DS} = -20V, V _{GS} =0V			-1	μA
I _{GSS}	Gate-Body Leakage Current	V _{GS} = 18V			110	nA
V _{GS(th)}	Gate Threshold Voltage	V _{DS} = V _{GS} , I _D =250μA	-0.45	-0.57	-0.9	V
R _{DS(ON)}	Static Drain-Source On-Resistance ²	V _{GS} =-4.5V, I _D =-4A	-	33	36	mΩ
DYNAMIC PARAMETERS						
C _{iss}	Input Capacitance	V _{GS} =0V, V _{DS} =10V, f=1MHz	600	751	905	pF
C _{oss}	Output Capacitance		80	115	150	pF
C _{rss}	Reverse Transfer Capacitance		48	80	115	pF
SWITCHING PARAMETERS						
Q _g	Total Gate Charge ²	V _{GS} =4.5V, V _{DS} =10V, I _D =4A	7.4	9.3	11	nC
Q _{gs}	Gate Source Charge		0.8	1	12	nC
Q _{gd}	Gate Drain Charge		1.3	2.2	3.1	nC
t _{d(on)}	Turn-On Delay Time	V _{GS} =-4.5V, V _{DS} =-10V, R _{GEN} =3Ω, R _L =2.5Ω		13		ns
t _{d(off)}	Turn-Off Delay Time			19		ns
t _{d(r)}	Turn-On Rise Time			9		ns
t _{d(f)}	Turn-Off Fall Time			29		ns
Thermal Resistance						
Symbol	Parameter		Typ	Max		Units
R _{θJC}	Junction to Case		-	43		°C/W
R _{θJA}	Junction to Ambient (t ≤ 10s)		-	65		°C/W

Test Circuits and Waveform

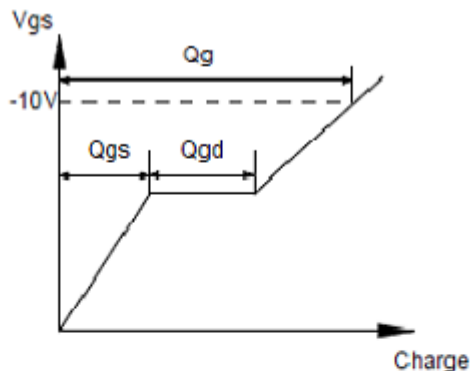
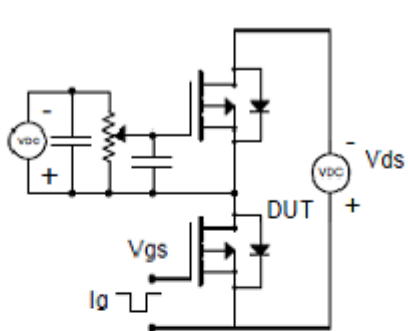

Resistive Switching Test Circuit & Waveforms

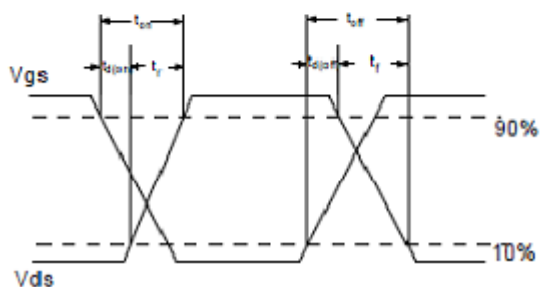
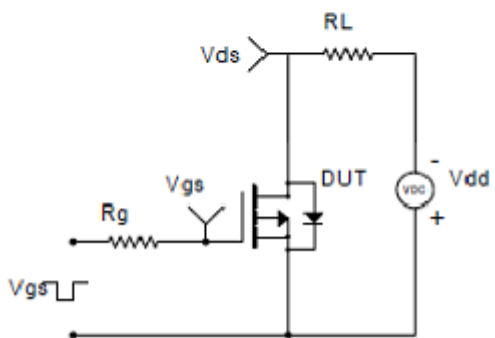

Diode Recovery Test Circuit & Waveforms

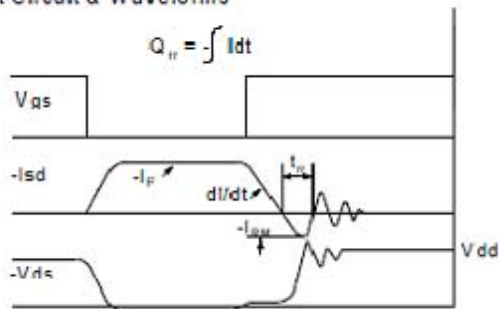
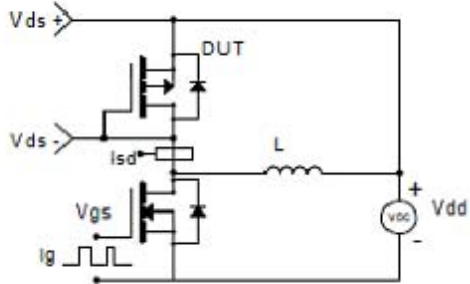

Typical Characteristics

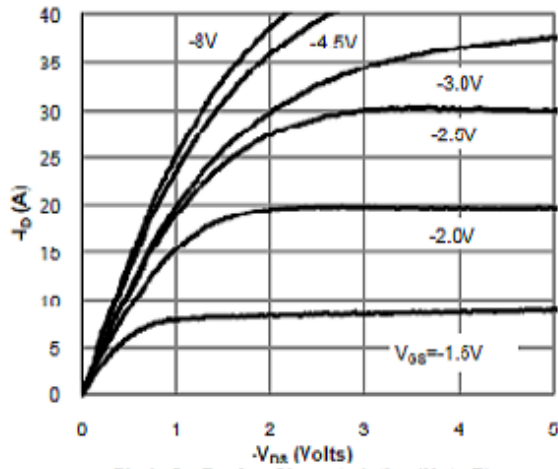

Fig 1: On-Region Characteristics (Note E)

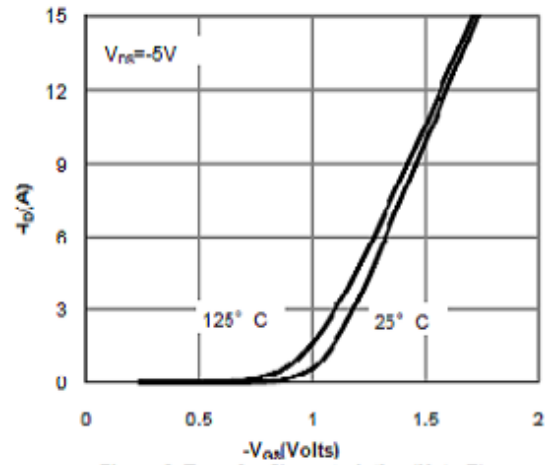

Figure 2: Transfer Characteristics (Note E)

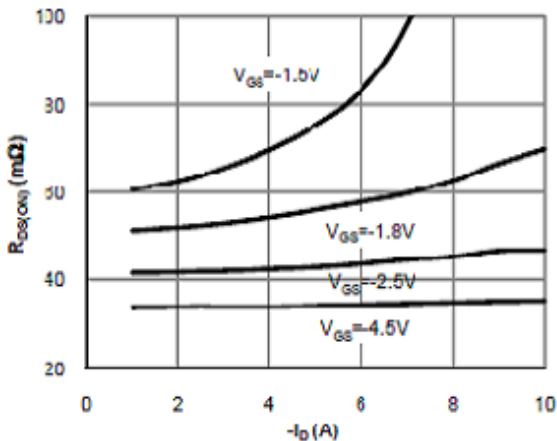

Figure 3: On-Resistance vs. Drain Current and Gate Voltage (Note E)

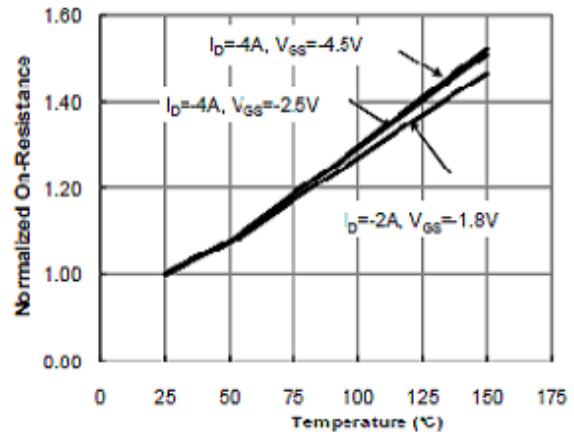

Figure 4: On-Resistance vs. Junction Temperature (Note E)

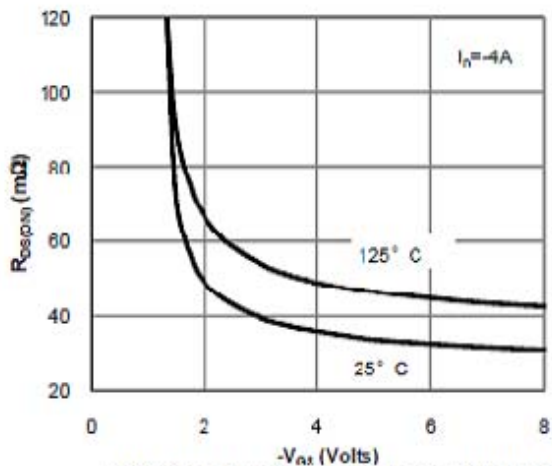

Figure 5: On-Resistance vs. Gate-Source Voltage (Note E)

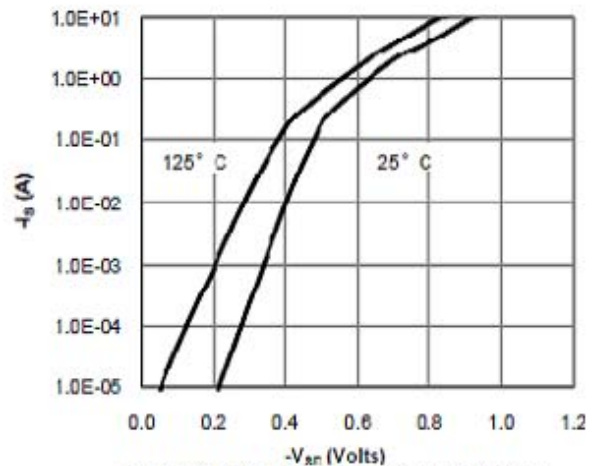

Figure 6: Body-Diode Characteristics (Note E)

Typical Characteristics

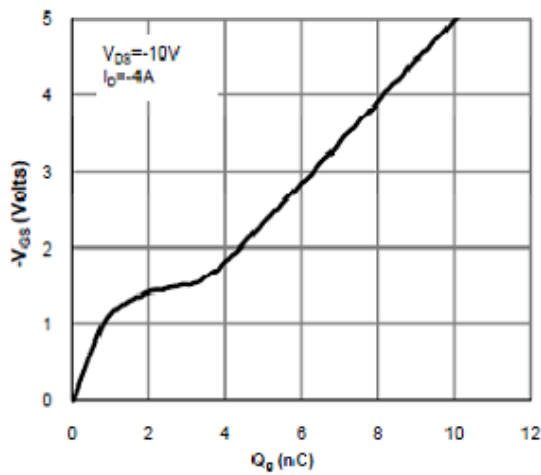

Figure 7: Gate-Charge Characteristics

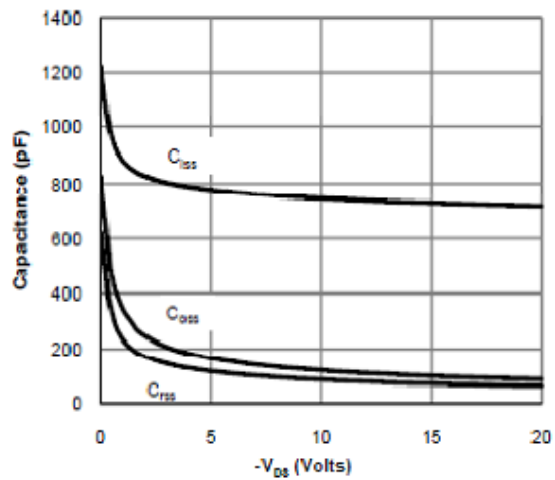

Figure 8: Capacitance Characteristics

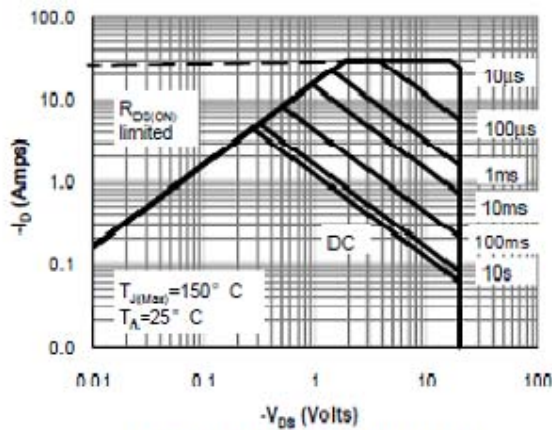

Figure 9: Maximum Forward Biased Safe Operating Area (Note F)

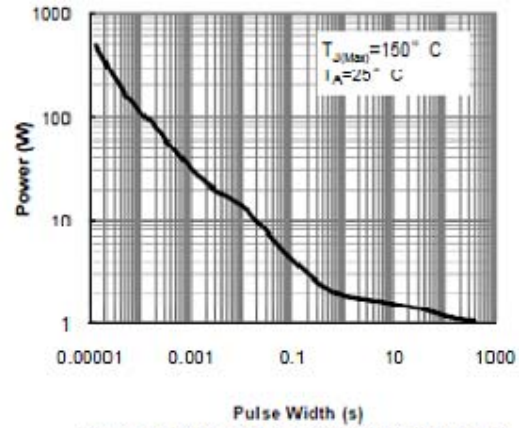

Figure 10: Single Pulse Power Rating Junction-to-Ambient (Note F)

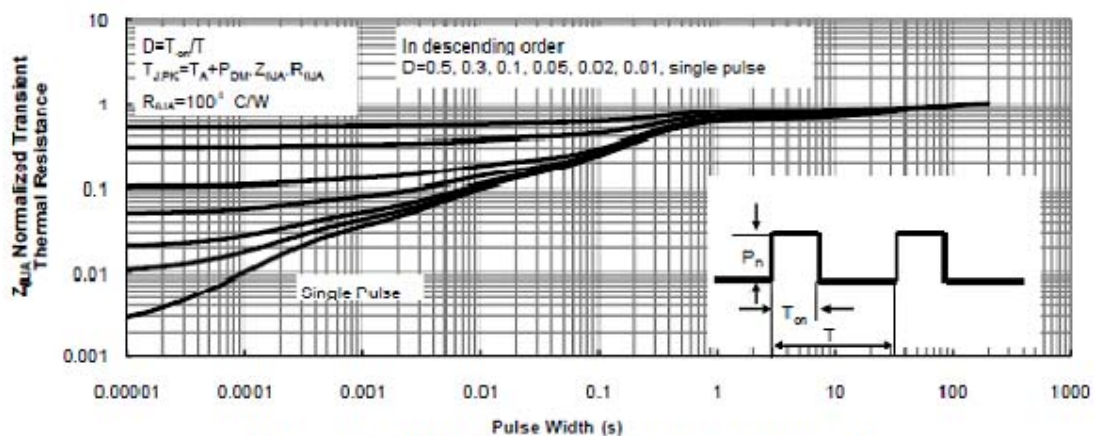
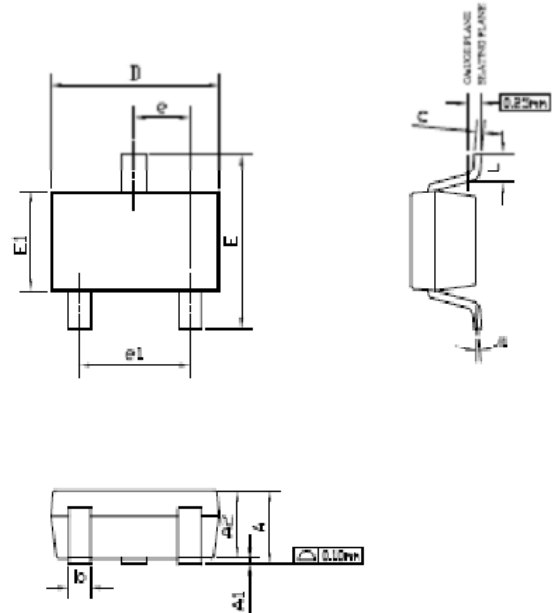

Figure 11: Normalized Maximum Transient Thermal Impedance (Note F)

SE3415

Package Outline Dimension

SOT-23



RECOMMENDED LAND PATTERN

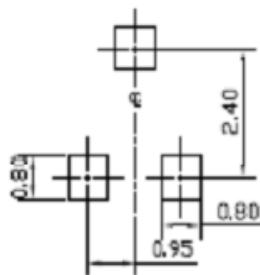

UNIT: mm

SYMBOLS	DIMENSIONS IN MILLIMETERS			DIMENSIONS IN INCHES		
	MIN	NOM	MAX	MIN	NOM	MAX
A	0.85	—	1.25	0.033	—	0.049
A1	0.00	—	0.13	0.000	—	0.005
A2	0.70	1.00	1.13	0.028	0.039	0.045
b	0.30	0.40	0.50	0.012	0.016	0.020
c	0.08	0.13	0.20	0.003	0.005	0.008
D	2.80	2.90	3.10	0.110	0.114	0.122
E	2.60	2.80	3.00	0.102	0.110	0.118
E1	1.40	1.60	1.80	0.055	0.063	0.071
e	λ95 BSC			0.037 BSC		
e1	1.90 BSC			0.075 BSC		
L	0.30	—	0.60	0.012	—	0.024
Bl	0°	5°	8°	0°	5°	8°

SE3415

The SINO-IC logo is a registered trademark of ShangHai Sino-IC Microelectronics Co., Ltd.

© 2005 SINO-IC - Printed in China - All rights reserved.

SHANGHAI SINO-IC MICROELECTRONICS CO., LTD

Add: Building 3, Room 3401-03, No.200 Zhangheng Road,
ZhangJiang Hi-Tech Park, Pudong, Shanghai 201203, China

Phone: +86-21-33932402 33932403

33932405 33933508 33933608

Fax: +86-21-33932401

Email: szrxw002@126.com

Website: <http://www.sino-ic.net>