

Product Summary

$V_{(BR)DSS}$	$R_{DS(on)MAX}$	I_D
-20V	520mΩ@-4.5V	-0.66A
	780mΩ@-2.5V	
	950mΩ(TYP)@-1.8V	

Feature

- Surface Mount Package
- P-Channel Switch with Low RDS(on)
- Operated at Low Logic Level Gate Drive
- ESD Protected

Application

- Load/Power Switching
- Interfacing, Logic Switching
- Battery Management for Ultra Small Portable Electronics

MARKING:

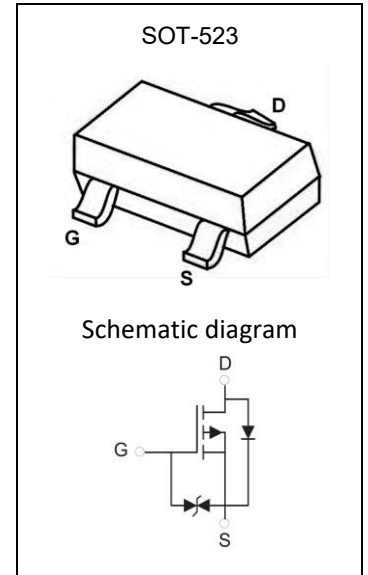
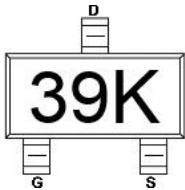

ABSOLUTE MAXIMUM RATINGS ($T_a=25^\circ\text{C}$ unless otherwise noted)

Parameter	Symbol	Value	Unit
Drain-Source Voltage	V_{DS}	-20	V
Gate-Source Voltage	V_{GS}	± 12	V
Continuous Drain Current ⁽¹⁾	I_D	-0.66	A
Pulsed Drain Current ($t_p=10\mu\text{s}$)	I_{DM}	-1.2	A
Power Dissipation ⁽¹⁾	P_D	150	mW
Thermal Resistance from Junction to Ambient ⁽¹⁾	$R_{\theta JA}$	833	$^\circ\text{C}/\text{W}$
Junction Temperature	T_J	150	$^\circ\text{C}$
Storage Temperature	T_{STG}	-55~ +150	$^\circ\text{C}$
Lead Temperature for Soldering Purposes(1/8" from case for 10s)	T_L	260	$^\circ\text{C}$

MOSFET ELECTRICAL CHARACTERISTICS (T_a=25°C unless otherwise noted)

Parameter	Symbol	Test Condition	Min	Type	Max	Unit
Static Characteristics						
Drain-source breakdown voltage	V _{(BR)DSS}	V _{GS} = 0V, I _D = -250μA	-20			V
Zero gate voltage drain current	I _{DSS}	V _{DS} = -20V, V _{GS} = 0V			-1	μA
Gate-body leakage current	I _{GSS}	V _{GS} = ±10V, V _{DS} = 0V			±20	μA
Gate threshold voltage ⁽²⁾	V _{GS(th)}	V _{DS} = V _{GS} , I _D = -250μA	-0.35	-0.61	-1.1	V
Drain-source on-resistance ⁽²⁾	R _{DS(on)}	V _{GS} = -4.5V, I _D = -1A		450	520	mΩ
		V _{GS} = -2.5V, I _D = -0.8A		650	780	
		V _{GS} = -1.8V, I _D = -0.5A		950		
Forward transconductance ⁽²⁾	g _{FS}	V _{DS} = -10V, I _D = -0.54A		1.2		S
Dynamic characteristics⁽⁴⁾						
Input Capacitance	C _{iss}	V _{DS} = -16V, V _{GS} = 0V, f = 1MHz		113		pF
Output Capacitance	C _{oss}			15		
Reverse Transfer Capacitance	C _{rss}			9		
Switching Characteristics⁽⁴⁾						
Turn-on delay time ⁽³⁾	t _{d(on)}	V _{DS} = -10V, I _D = -200mA, V _{GS} = -4.5V, R _G = 10Ω		9		ns
Turn-on rise time ⁽³⁾	t _r			5.7		
Turn-off delay time ⁽³⁾	t _{d(off)}			32.6		
Turn-off fall time ⁽³⁾	t _f			20.3		
Source-Drain Diode characteristics						
Diode forward voltage	V _{DS}	I _S = -0.5A, V _{GS} = 0V			-1.2	V

Notes:

1. Surface mounted on FR4 board using the minimum recommended pad size.
2. Pulse Test : Pulse Width=300μs, Duty Cycle=2%.
3. Switching characteristics are independent of operating junction temperatures.
4. Guaranteed by design, not subject to producing.

Typical Electrical and Thermal Characteristics

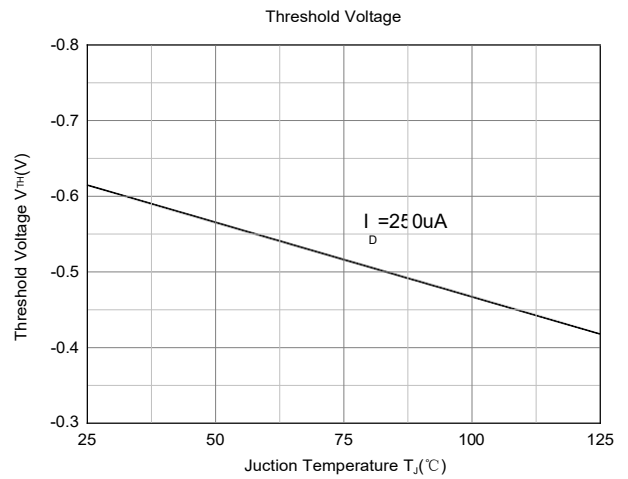
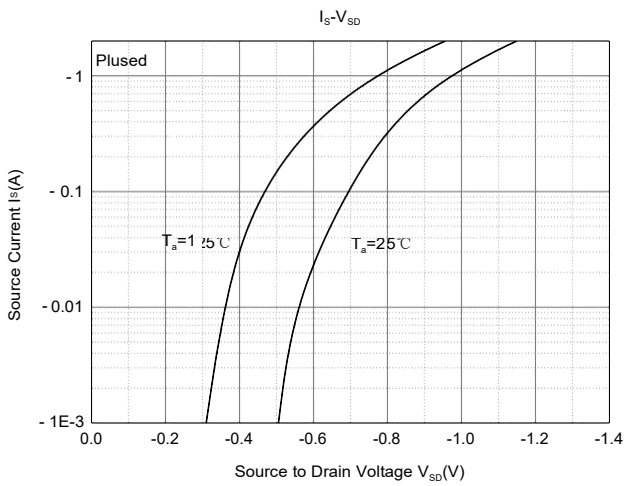
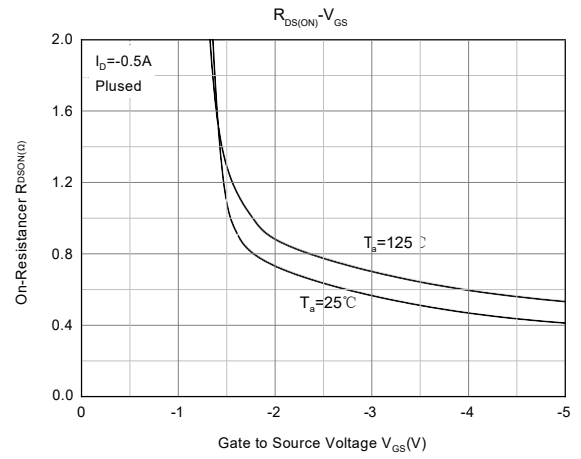
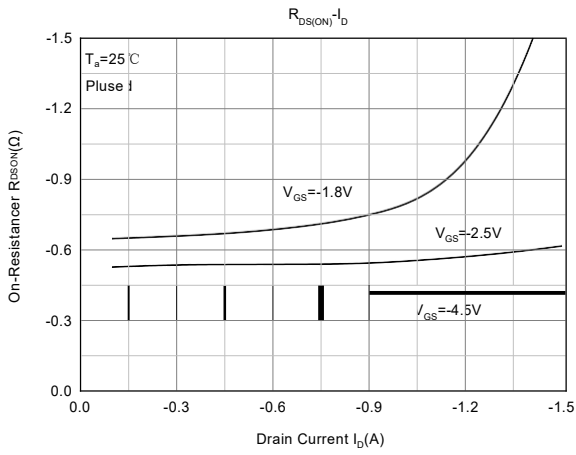
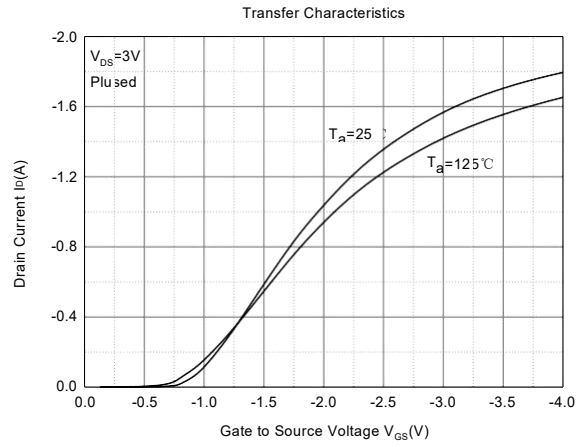
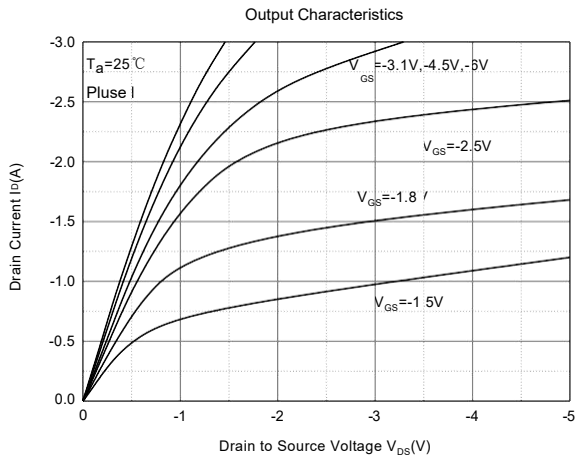

SOT-523 Package Information

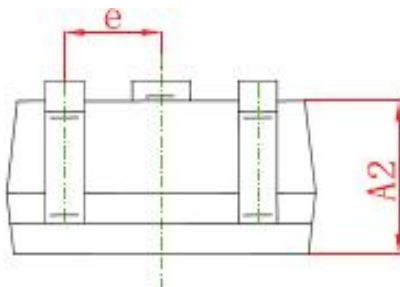
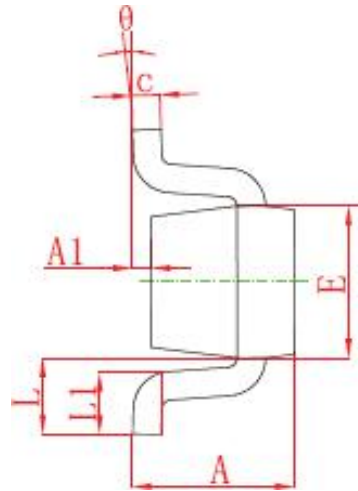
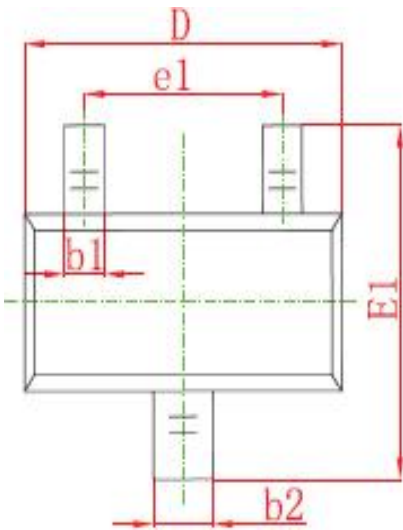

Symbol	Dimensions In Millimeters	
	Min	Max
A	0.700	0.90
A1	0.000	0.100
A2	0.700	0.800
b1	0.150	0.250
b2	0.250	0.350
C	0.100	0.200
D	1.500	1.700
E	0.700	0.900
E1	1.450	1.750
e	0.5000 TYP	
e1	0.900	1.100
L	0.400 REF	
L1	0.260	0.450
θ	0°	8°

SOT-523 Tape and Reel

SOT-523 Tape and reel

SOT-523 Embossed Carrier Tape

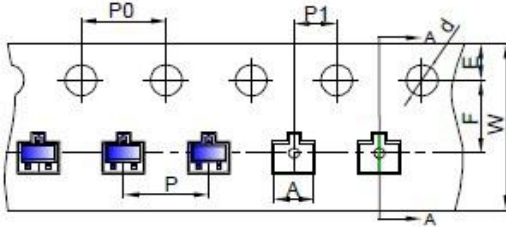

Dimensions are in millimeter										
Pkg type	A	B	C	d	E	F	P0	P	P1	W
SOT-523	1.85	1.85	0.875	Ø1.50	1.75	3.50	4.00	4.00	2.00	8.00

SOT-523 Tape Leader and Trailer

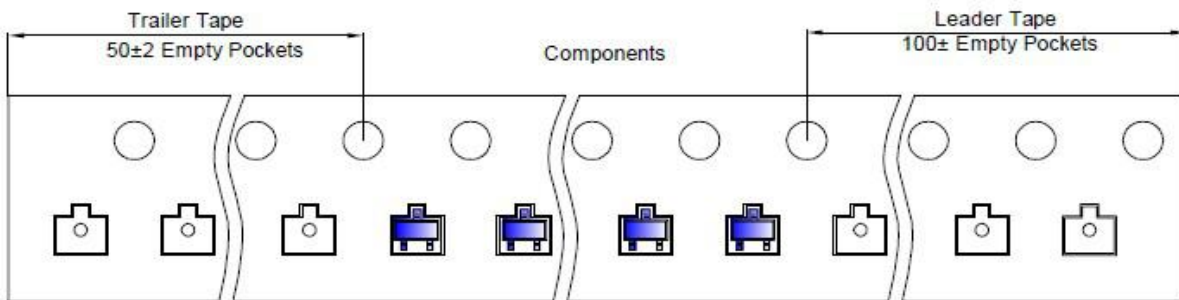

SOT-523 Reel

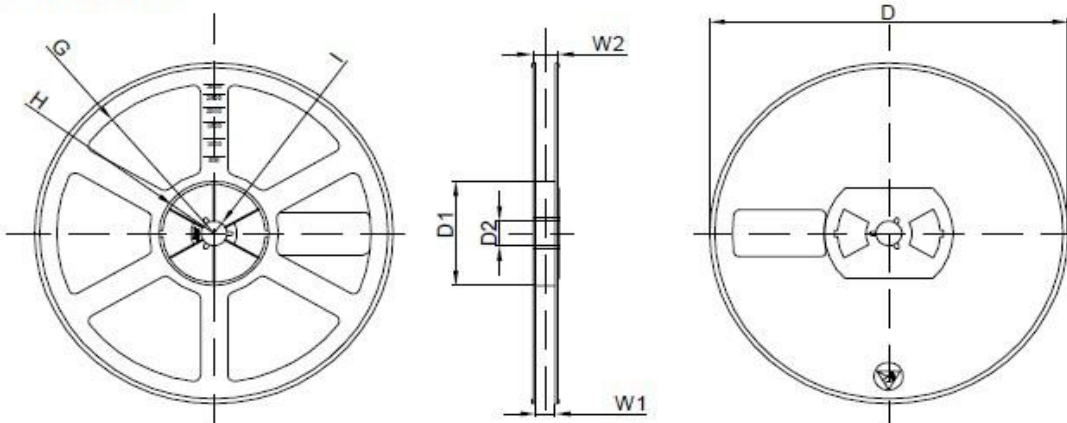

Dimensions are in millimeter								
Reel Option	D	D1	D2	G	H	I	W1	W2
7" Dia	Ø178.00	54.40	13.00	R78.00	R25.60	R6.50	9.50	12.30

REEL	Reel Size	Box	Box Size(mm)	Carton	Carton Size(mm)	G.W.(kg)
3000 pcs	7 inch	30,000 pcs	203×203×195	120,000 pcs	438×438×220	