



MOT65R380F/MOT65R380A N-CHANNEL MOSFET

■ PRODUCT CHARACTERISTICS

VDSS	650V
$R_{DS(on)max}(@V_{GS} = 10\text{ V})$	0.38Ω
Qg@type	14nC
ID	11A

■ APPLICATIONS

- * Power factor correction
- * Switched mode power supplies
- * Uninterruptible power supply

■ FEATURES

- * low $R_{DS(on)}$
- * low gate charge
- * 100% UIS tested
- * RoHS compliant

Symbol

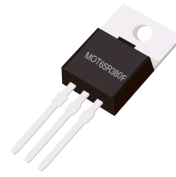
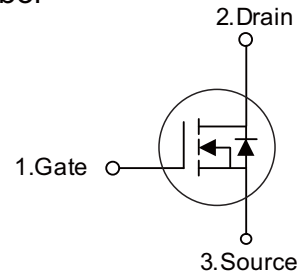

TO-220

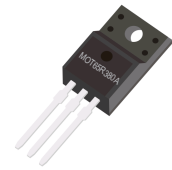

TO-220F

■ ORDER INFORMATION

Order codes		Package	Packing
Halogen-Free	Halogen		
N/A	MOT65R380F	TO-220F	50 pieces/Tube
N/A	MOT65R380A	TO-220	50 pieces/Tube

■ ABSOLUTE MAXIMUM RATINGS ($T_C=25^\circ\text{C}$ unless otherwise specified)

Parameter	Symbol	Value	Unit
Drain-Source Voltage	V_{DSS}	650	V
Continuous drain current	I_D	($T_C = 25^\circ\text{C}$)	11
		($T_C = 100^\circ\text{C}$)	8.2
Pulsed drain current ¹⁾	I_{DM}	30	A
Gate-Source voltage	V_{GSS}	± 30	V
Avalanche energy, single pulse ²⁾	E_{AS}	245	mJ
Avalanche current, repetitive ³⁾	I_{AR}	11	A
Power Dissipation TO-220	P_D	90	W
($T_C = 25^\circ\text{C}$) - Derate above 25°C		0.72	W/ $^\circ\text{C}$
Power Dissipation TO-220F ($T_C = 25^\circ\text{C}$)		31.8	W
- Derate above 25°C		0.26	W/ $^\circ\text{C}$
Operating and Storage Temperature Range	T_J, T_{STG}	-55 to +150	$^\circ\text{C}$
Continuous diode forward current	I_S	11	A
Diode pulse current	$I_{S,pulse}$	30	A

■ THERMAL CHARACTERISTICS

Parameter		Symbol	Value	Unit
Thermal Resistance, Junction-to-Case	TO-220	$R_{\theta JC}$	1.39	$^\circ\text{C}/\text{W}$
	TO-220F		3.9	$^\circ\text{C}/\text{W}$
Thermal Resistance, Junction-to-Ambient	TO-220	$R_{\theta JA}$	45	$^\circ\text{C}/\text{W}$
	TO-220F		53	$^\circ\text{C}/\text{W}$



■ ELECTRICAL CHARACTERISTICS ($T_J = 25^\circ\text{C}$, unless otherwise specified)

Parameter	Symbol	Test Condition	Min.	Typ.	Max.	Unit
Static characteristics						
Drain-source breakdown voltage	BV_{DSS}	$V_{GS}=0\text{ V}, I_D=0.25\text{ mA}$	650	-	-	V
Gate threshold voltage	$V_{GS(th)}$	$V_{DS}=V_{GS}, I_D=0.25\text{ mA}$	2.5	3.5	4.5	V
Drain cut-off current	I_{DSS}	$V_{DS}=650\text{ V}, V_{GS}=0\text{ V}, T_J = 25^\circ\text{C}$			1	μA
		$T_J = 125^\circ\text{C}$	-	10		
Gate leakage current, Forward	I_{GSSF}	$V_{GS}=30\text{ V}, V_{DS}=0\text{ V}$	-	-	100	nA
Gate leakage current, Reverse	I_{GSSR}	$V_{GS}=-30\text{ V}, V_{DS}=0\text{ V}$	-	-	-100	nA
Drain-source on-state resistance	$R_{DS(on)}$	$V_{GS}=10\text{ V}, I_D=5.5\text{ A}, T_J = 25^\circ\text{C}$	-	0.33	0.38	Ω
		$T_J = 150^\circ\text{C}$	-	0.9	-	
Gate resistance	R_G	$f=1\text{ MHz}, \text{open drain}$	-	5.7	-	Ω
Dynamic characteristics						
Input capacitance	C_{iss}	$V_{DS} = 25\text{ V}, V_{GS} = 0\text{ V},$ $f = 1\text{ MHz}$	-	560	-	μF
Output capacitance	C_{oss}		-	216	-	
Reverse transfer capacitance	C_{rss}		-	1.2	-	
Turn-on delay time	$t_{d(on)}$	$V_{DD} = 400\text{ V}, I_D = 5.5\text{ A}$ $R_G = 10\Omega, V_{GS}=15\text{ V}$	-	20.6	-	ns
Rise time	t_r		-	32	-	
Turn-off delay time	$t_{d(off)}$		-	62	-	
Fall time	t_f		-	12.5	-	
Gate charge characteristics						
Gate to source charge	Q_{gs}	$V_{DD}=400\text{ V}, I_D=5.5\text{ A},$ $V_{GS}=0\text{ to }10\text{ V}$	-	4.8	-	nC
Gate to drain charge	Q_{gd}		-	4.7	-	
Gate charge total	Q_g		-	14.7	-	
Gate plateau voltage	$V_{plateau}$		-	6	-	V
Reverse diode characteristics						
Diode forward voltage	V_{SD}	$V_{GS}=0\text{ V}, I_F=5.5\text{ A}$	-	1.2	-	V
Reverse recovery time	t_{rr}	$V_R=400\text{ V}, I_F=5.5\text{ A},$ $dI_F/dt=100\text{ A}/\mu\text{s}$	-	234	-	ns
Reverse recovery charge	Q_{rr}		-	4.4	-	μC
Peak reverse recovery current	I_{rrm}		-	18.7	-	A

Notes:

- Limited by maximum junction temperature, maximum duty cycle is 0.75.
- $I_{AS} = 3\text{ A}, V_{DD} = 60\text{ V}, \text{Starting } T_J = 25^\circ\text{C}.$
- Repetitive Rating: Pulse width limited by maximum junction temperature.



■ ELECTRICAL CHARACTERISTICS DIAGRAMS

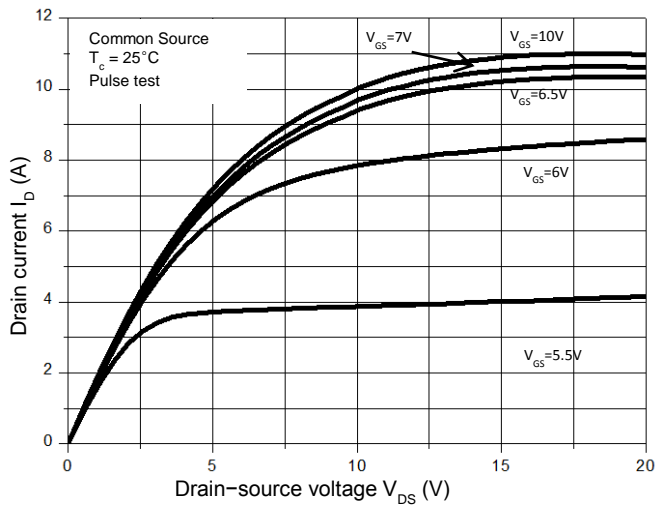

Figure 1. On-Region Characteristics

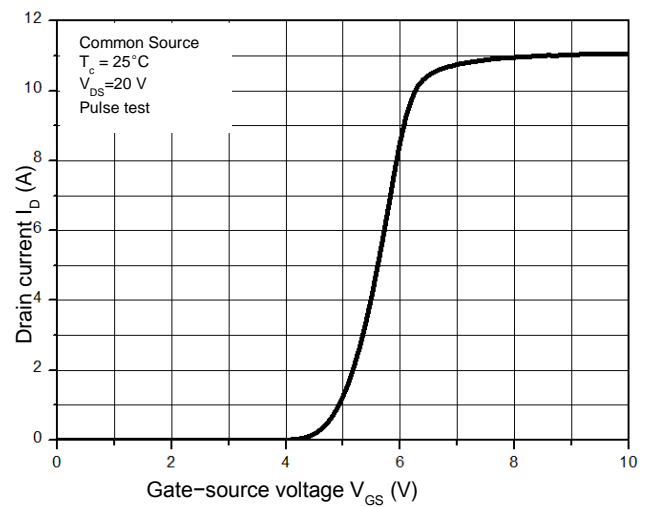

Figure 2. Transfer Characteristics

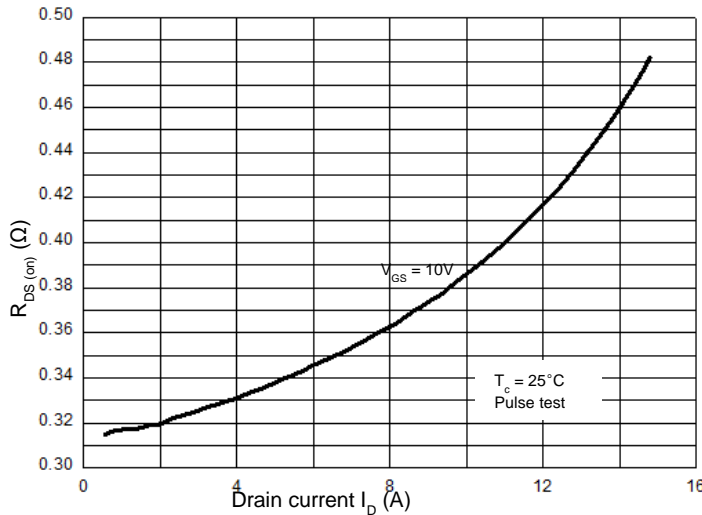

Figure 3. On-Resistance Variation vs. Drain Current

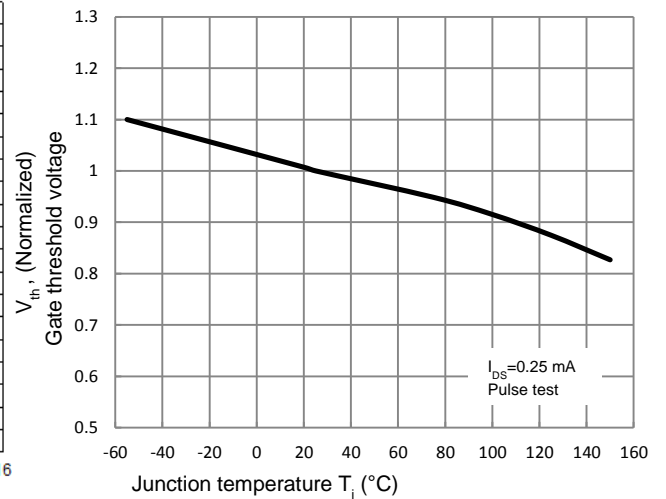

Figure 4. Threshold Voltage vs. Temperature

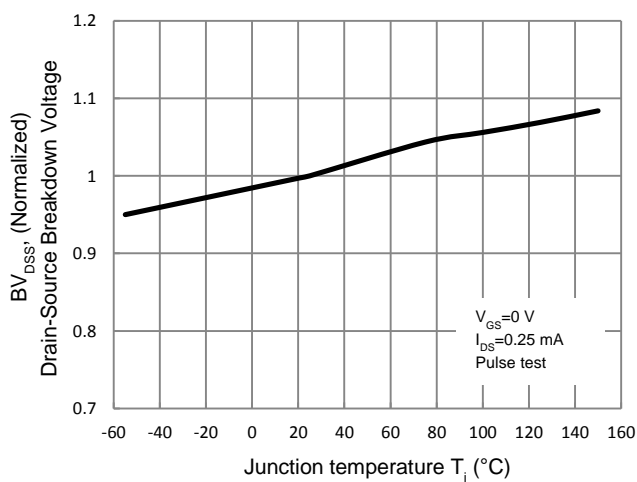

Figure 5. Breakdown Voltage vs. Temperature

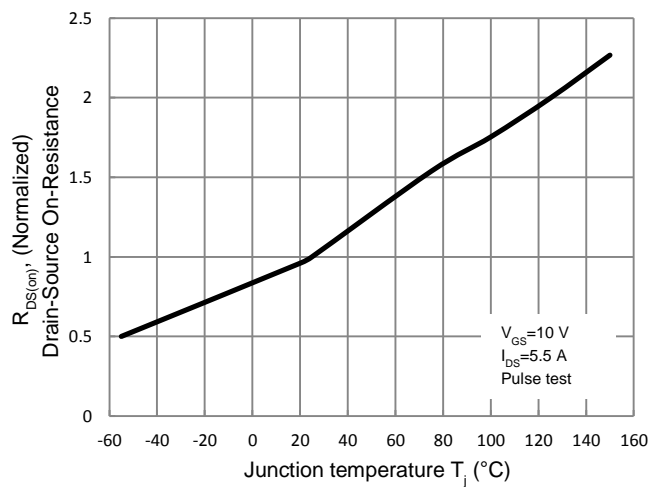

Figure 6. On-Resistance vs. Temperature



■ ELECTRICAL CHARACTERISTICS DIAGRAMS(Cont.)

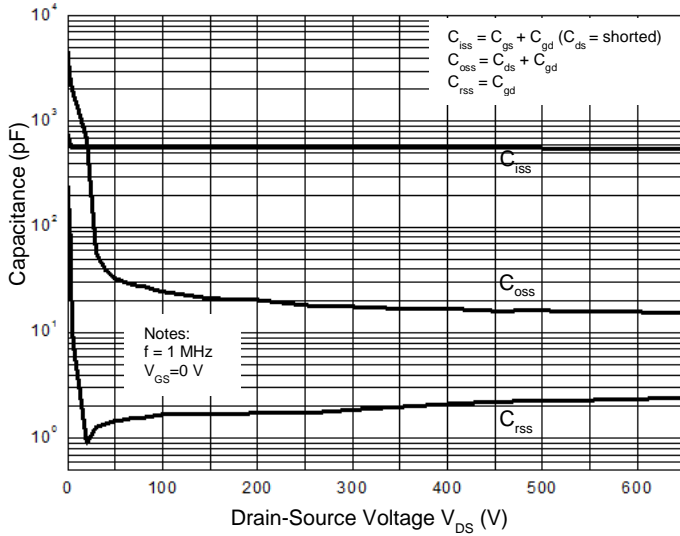

Figure 7. Capacitance Characteristics

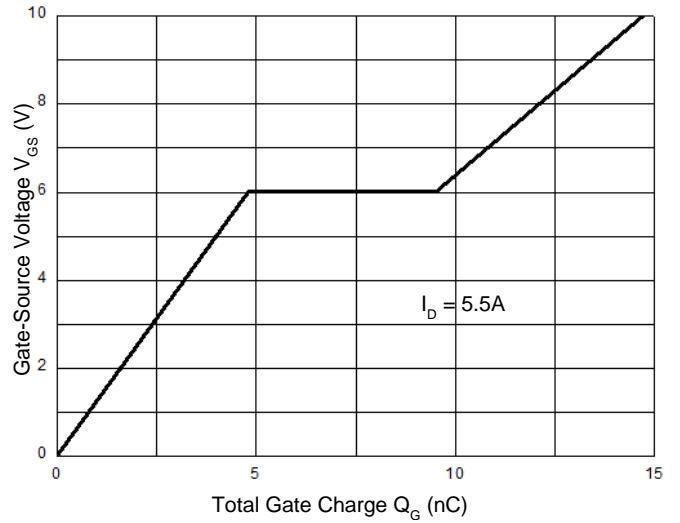

Figure 8. Gate Charge Characteristic

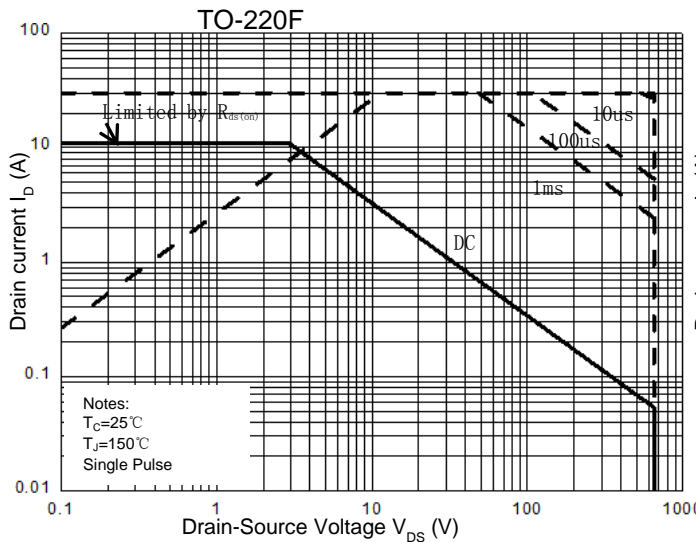

Figure 9.1 Maximum Safe Operating Area

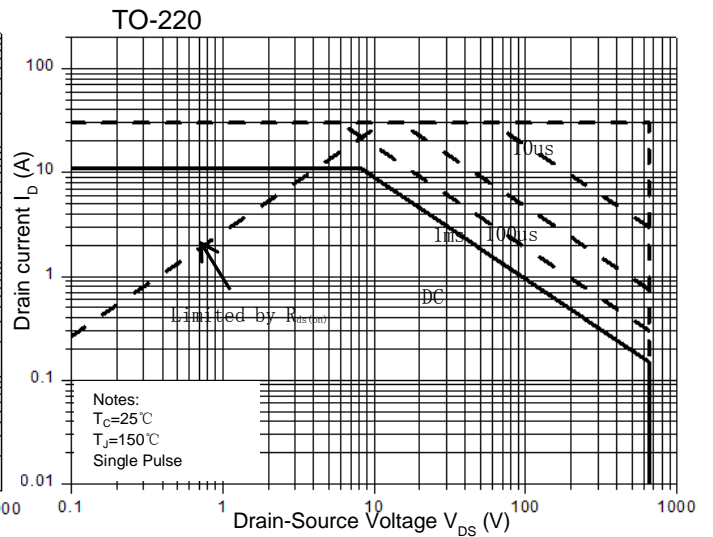

Figure 9.2 Maximum Safe Operating Area

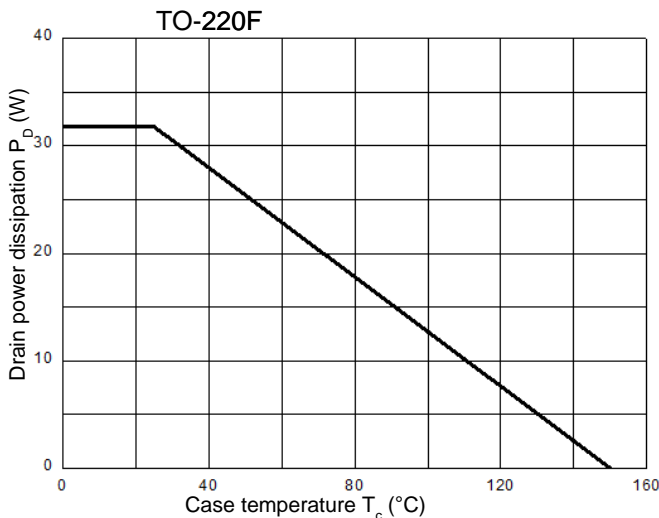

Figure 10.1 Power Dissipation vs. Temperature

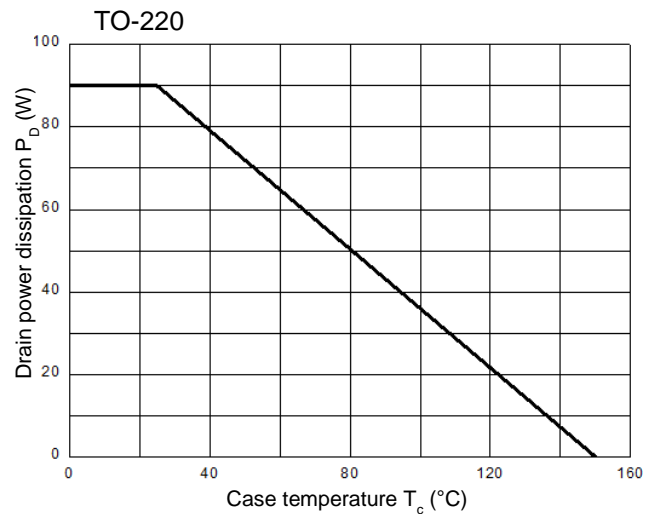
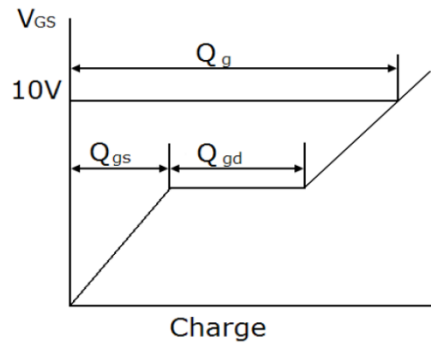
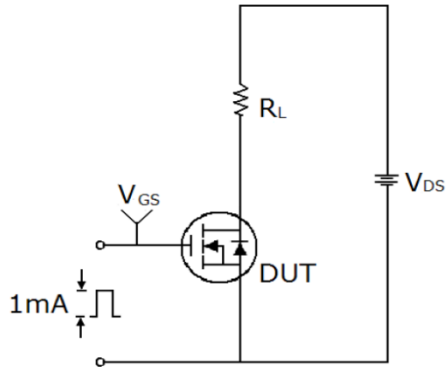
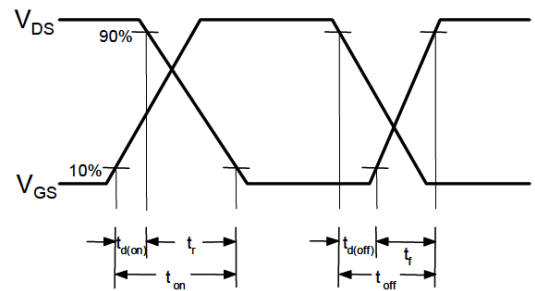
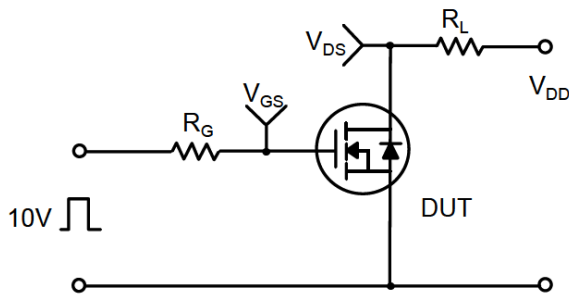

Figure 10.2 Power Dissipation vs. Temperature

■ TEST CIRCUITS AND WAVEFORMS



Switching Test Circuit & Waveforms



Unclamped Inductive Switching Test Circuit & Waveforms

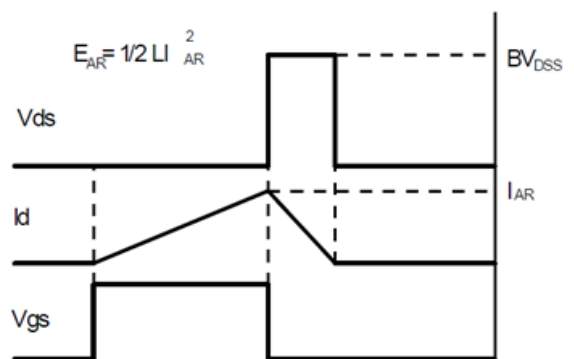
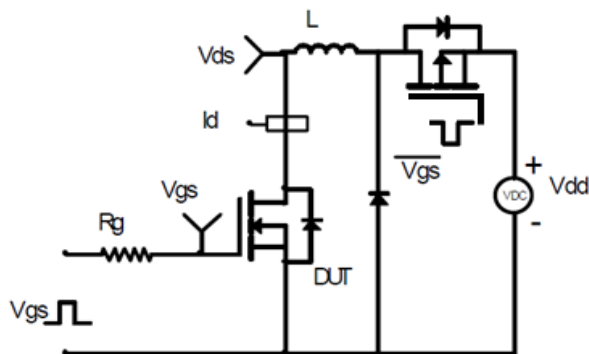

■ TO-220F-3L PACKAGE OUTLINE DIMENSIONS

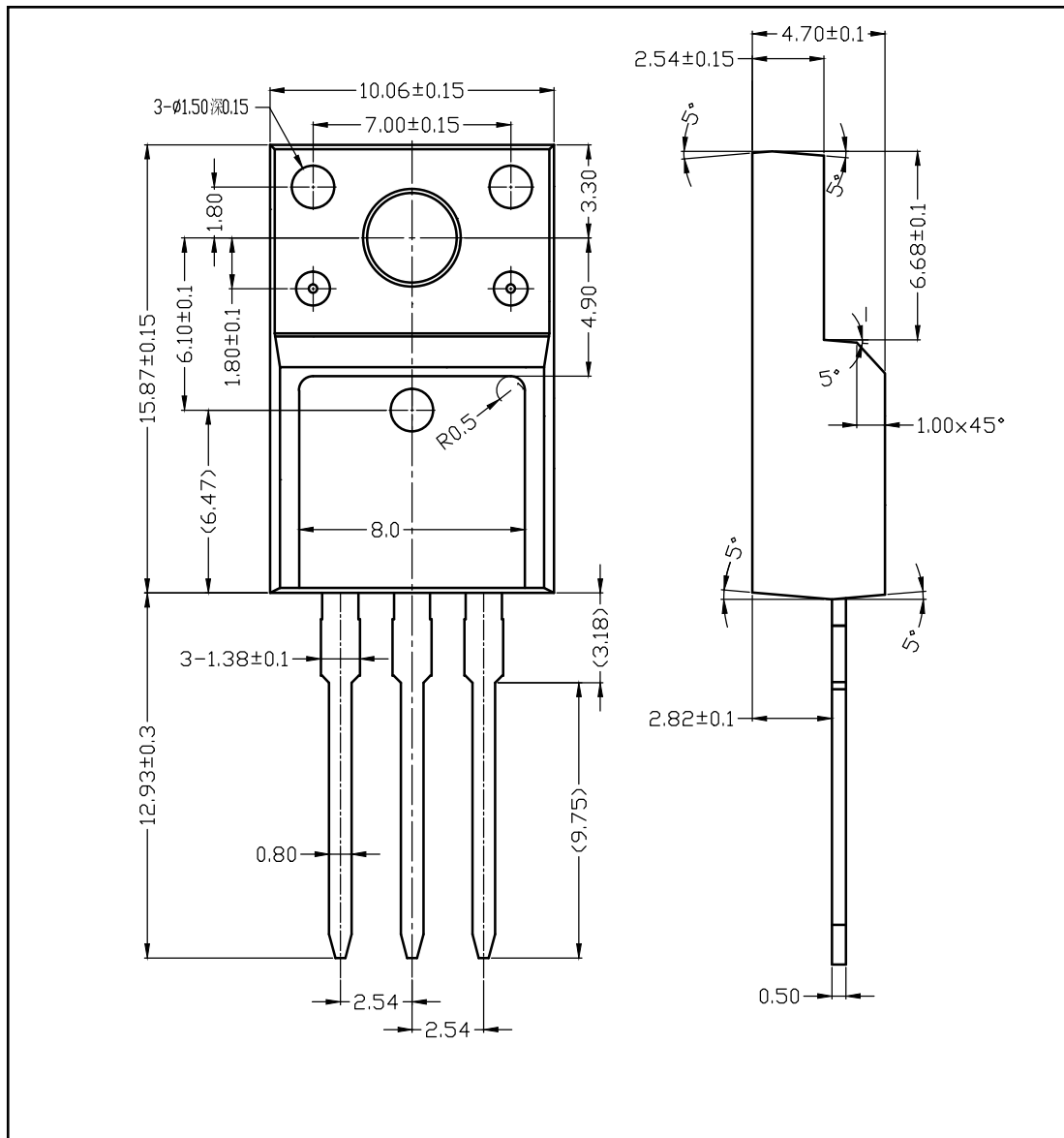

■ TO-220-3L PACKAGE OUTLINE DIMENSIONS

