

### GENERAL DESCRIPTION

The SGM4807 is an audio Click-Pop eliminator for portable multimedia devices. Operating from a 1.7V to 5V power supply, the SGM4807 connects to the output of the existing system amplifier and provides a low-impedance path to ground during startup and shutdown. The inputs INL and INR accept voltage swings from +V<sub>CC</sub> to -V<sub>CC</sub>. The power-up and power-down transients are shunted to ground to prevent Clicks-Pops from becoming audible.

The SGM4807 features two low-impedance analog switches controlled by mute events that open and close the switches. The mute events include under-voltage of V<sub>CC</sub> and external power supply, power-up, power-down and high to low logical level change of  $\overline{\text{MUTE}}$  pin. The switches are open during normal operation and have no impact on the output signal. During startup and shutdown of the amplifier, the SGM4807 can be activated to short the outputs to ground and prevent Clicks-Pops from pulling current through the line-outs.

The SGM4807 is available in Green TDFN-2×2-8L, MSOP-8 and WLCSP-1.57×0.80-8B packages. It operates over an ambient temperature range of -40°C to +85°C.

### FEATURES

- Distortion-Free, Click-Pop Elimination
- 1.5μA (TYP) Supply Current
- 1.7V to 5V Single Supply Operation
- 600kΩ Pull-Low Resistor at  $\overline{\text{MUTE}}$  Pin
- Available in Green TDFN-2×2-8L, MSOP-8 and WLCSP-1.57×0.80-8B Packages
- -40°C to +85°C Operating Temperature Range

### APPLICATIONS

- Mobile Phones
- Smart Phones
- Mobile Internet Devices
- Portable Gaming Consoles
- Portable Media Players
- Notebook Computers

### TYPICAL APPLICATION

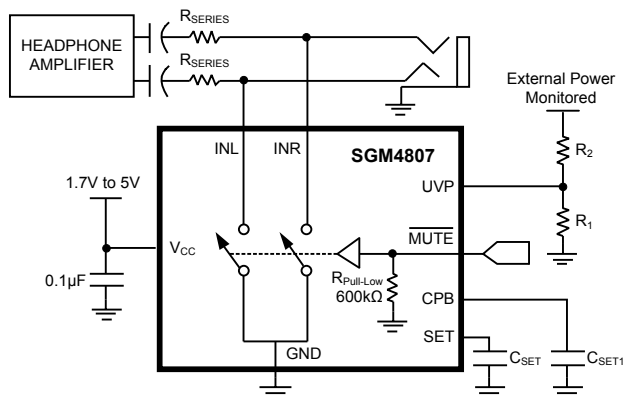

Figure 1. Typical Application Circuit

**PACKAGE/ORDERING INFORMATION**

MODEL	PACKAGE DESCRIPTION	SPECIFIED TEMPERATURE RANGE	ORDERING NUMBER	PACKAGE MARKING	PACKING OPTION
SGM4807	TDFN-2x2-8L	-40°C to +85°C	SGM4807YTDE8G/TR	4807 XXXX	Tape and Reel, 3000
	MSOP-8	-40°C to +85°C	SGM4807YMS8G/TR	SGM4807 YMS8 XXXXX	Tape and Reel, 4000
	WLCSP-1.57x0.80-8B	-40°C to +85°C	SGM4807YG/TR	8EXX	Tape and Reel, 4000

NOTE: XX = Date Code, XXXX = Date Code, XXXXX = Date Code and Vendor Code.

Green (RoHS & HSF): SG Micro Corp defines "Green" to mean Pb-Free (RoHS compatible) and free of halogen substances. If you have additional comments or questions, please contact your SGMICRO representative directly.

**ABSOLUTE MAXIMUM RATINGS**

V<sub>CC</sub>,  $\overline{\text{MUTE}}$ , SET, CPB, UVP to GND .....-0.3V to +6V  
 INL, INR to GND .....-V<sub>CC</sub> -0.3V to +V<sub>CC</sub> + 0.3V  
 Continuous Current In/Out of V<sub>CC</sub> ..... 30mA  
 Continuous Current In/Out of  $\overline{\text{MUTE}}$  ..... 30mA  
 Continuous Current In/Out of SET, CPB, UVP ..... 30mA  
 Continuous Current In/Out of INL, INR and GND ..... 390mA  
 Junction Temperature ..... +150°C  
 Storage Temperature Range ..... -65°C to +150°C  
 Lead Temperature (Soldering, 10s) ..... +260°C  
 ESD Susceptibility  
 HBM ..... 8000V  
 MM ..... 400V  
 CDM ..... 1000V

**RECOMMENDED OPERATING CONDITIONS**

Operating Voltage Range ..... 1.7V to 5V  
 Operating Temperature Range ..... -40°C to +85°C

**OVERSTRESS CAUTION**

Stresses beyond those listed may cause permanent damage to the device. Functional operation of the device at these or any other conditions beyond those indicated in the operational section of the specification is not implied. Exposure to absolute maximum rating conditions for extended periods may affect reliability.

**ESD SENSITIVITY CAUTION**

This integrated circuit can be damaged by ESD if you don't pay attention to ESD protection. SGMICRO recommends that all integrated circuits be handled with appropriate precautions. Failure to observe proper handling and installation procedures can cause damage. ESD damage can range from subtle performance degradation to complete device failure. Precision integrated circuits may be more susceptible to damage because very small parametric changes could cause the device not to meet its published specifications.

**DISCLAIMER**

SG Micro Corp reserves the right to make any change in circuit design, specification or other related things if necessary without notice at any time

PIN CONFIGURATIONS

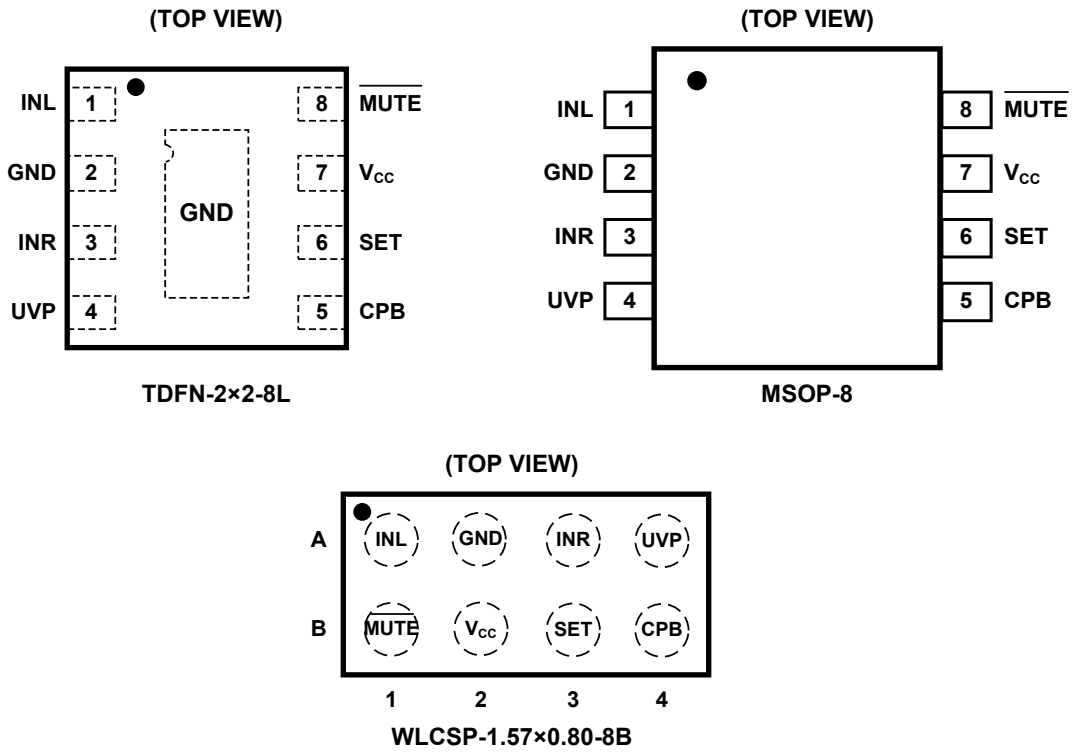

PIN DESCRIPTION

PIN		NAME	FUNCTION
TDFN-2x2-8L/ MSOP-8	WLCSP- 1.57x0.80-8B		
1	A1	INL	Left-Channel Input. Connect INL in between the output coupling capacitor and the headphone jack.
2	A2	GND	Ground.
3	A3	INR	Right-Channel Input. Connect INR in between the output coupling capacitor and the headphone jack.
4	A4	UVP	Under-Voltage Protection Input. When UVP event happens, chip will be in mute status.
5	B4	CPB	Power-On Blanking Time Adjusting. Connect a capacitor from CPB pin to GND to program the power-on blanking time. Chip is in mute status during power-on blanking time.
6	B3	SET	Turn-Off Time Set. Connect an external capacitor in between SET and GND to set the switch open delay; see the Setting the Turn-Off Time section for more information.
7	B2	V <sub>CC</sub>	Power Supply.
8	B1	MUTE	Active Low Enable. When MUTE = "Low", chip enters into mute status; when MUTE = "High", chip works normally. There is one 600kΩ pull-low resistor at MUTE pin.

## ELECTRICAL CHARACTERISTICS

(V<sub>CC</sub> = 5.0V, V<sub>GND</sub> = 0V, Full = -40°C to +85°C, typical values are at T<sub>A</sub> = +25°C, unless otherwise noted.)

PARAMETER	SYMBOL	CONDITIONS	TEMP	MIN	TYP	MAX	UNITS
Supply Voltage Range	V <sub>CC</sub>	Guaranteed by R <sub>ON</sub> test		1.7		5.5	V
Recommended Supply Voltage Range <sup>(1)</sup>	V <sub>CC</sub>	I <sub>IN</sub> = -3.5mA		1.7		5.0	V
Input Voltage Range	V <sub>IN</sub>	Guaranteed by input leakage current test		-V <sub>CC</sub>		+V <sub>CC</sub>	V
Supply Current <sup>(2)</sup>	I <sub>CC</sub>	V <sub>CC</sub> = 5.0V	+25°C		1.5	2	μA
			Full			2.5	
Switch On-Resistance	R <sub>ON</sub>	V <sub>CC</sub> = 3.3V	+25°C		110	150	mΩ
			Full			175	
		V <sub>CC</sub> = 5.0V	+25°C		90	120	
			Full			145	
Switch On-Resistance (WLCSP)	R <sub>ON(WLCSP)</sub>	V <sub>CC</sub> = 3.3V	+25°C		82	110	mΩ
			Full			135	
		V <sub>CC</sub> = 5.0V	+25°C		65	88	
			Full			105	
Click-Pop Reduction		R <sub>SERIES</sub> = 30Ω, R <sub>LOAD</sub> = 16Ω	+25°C		45		dB
Click-Pop Reduction (WLCSP)		R <sub>SERIES</sub> = 30Ω, R <sub>LOAD</sub> = 16Ω	+25°C		48		dB
Input Leakage Current	I <sub>IN</sub>	V <sub>IN</sub> = -5.0V, V <sub>CC</sub> = 5.0V	+25°C		±0.2		μA
			Full			±1	
		V <sub>IN</sub> = V <sub>CC</sub> , V <sub>CC</sub> = 5.0V	+25°C		±0.1		
			Full			±1	
$\overline{\text{MUTE}}$ Leakage Current	I <sub><math>\overline{\text{MUTE}}</math></sub>	V <sub>CC</sub> = 5.0V, V <sub><math>\overline{\text{MUTE}}</math></sub> = 0V	+25°C		±0.1		μA
			Full			±1	
$\overline{\text{MUTE}}$ Input-Voltage High	V <sub>IH</sub>		+25°C	1.5			V
$\overline{\text{MUTE}}$ Input-Voltage Low	V <sub>IL</sub>		+25°C			0.4	V
Under-Voltage Detection Threshold	V <sub>UVPTH</sub>	V <sub>CC</sub> = 5.0V, $\overline{\text{MUTE}}$ = "High"	+25°C	1.14	1.2	1.26	V
Pull-Low Resistor at $\overline{\text{MUTE}}$ Pin	R <sub>PULL-LOW</sub>	V <sub>CC</sub> = 5.0V	+25°C		600		kΩ
Power-On Blanking Time of Mute Status	t <sub>PB</sub>	C <sub>SET1</sub> = 500pF, Figure 1	+25°C		2.6		ms
Turn-On Time	t <sub>ON</sub>	Measured from $\overline{\text{MUTE}}$ = GND and input voltage settled to 90% of its final value, Figure 2	+25°C		110		ns
Turn-Off Time	t <sub>OFF</sub>	C <sub>SET</sub> = 500pF, Figure 2	+25°C	5	13	17	ms
		C <sub>SET</sub> = 50pF, Figure 2	+25°C		1.5		
		C <sub>SET</sub> = 50nF, Figure 2	+25°C		1300		

## NOTES:

- Operating within the recommended supply voltage range ensures that negative audio signals are not limited by the device. Supply voltages above the recommended supply voltage range may limit the headphone amplifier's maximum output voltage.
- Supply current is measured when switches are off.

TYPICAL PERFORMANCE CHARACTERISTICS

V<sub>CC</sub> = 5.0V, V<sub>GND</sub> = 0V, typical values are at T<sub>A</sub> = +25°C, unless otherwise noted.

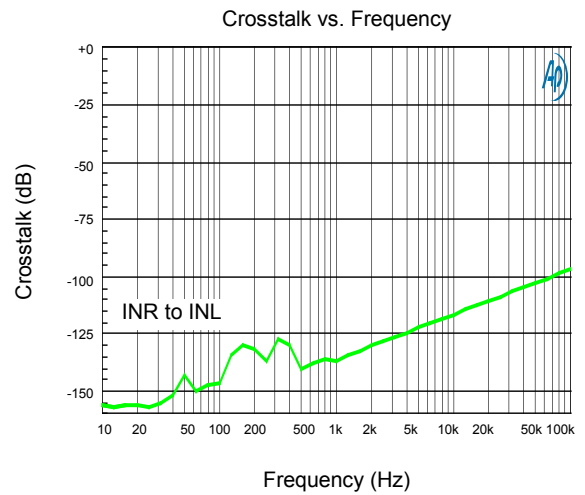
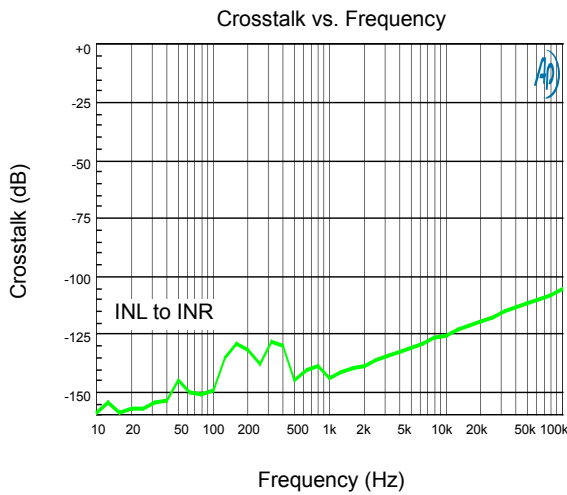
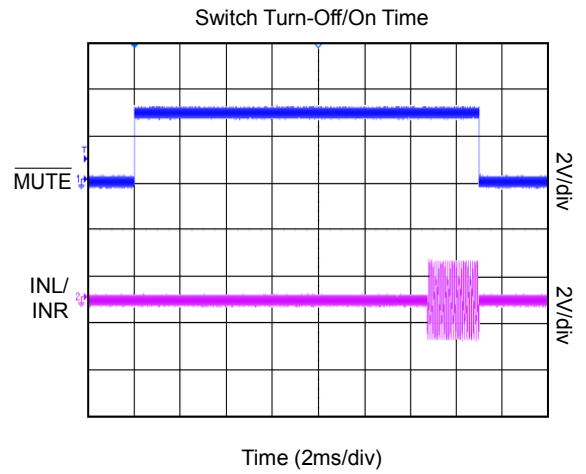
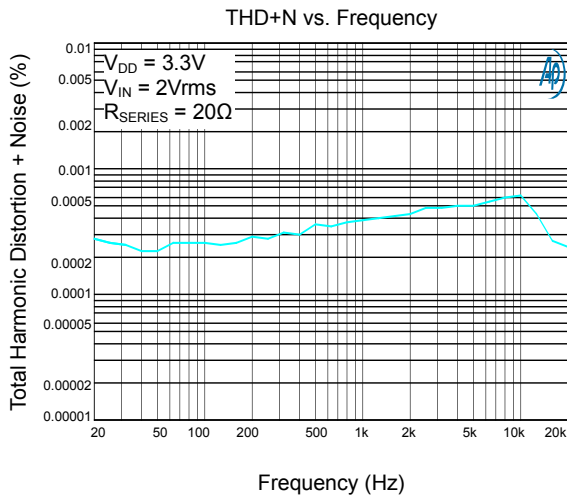

TYPICAL PERFORMANCE CHARACTERISTICS (continued)

V<sub>CC</sub> = 5.0V, V<sub>GND</sub> = 0V, typical values are at T<sub>A</sub> = +25°C, unless otherwise noted.

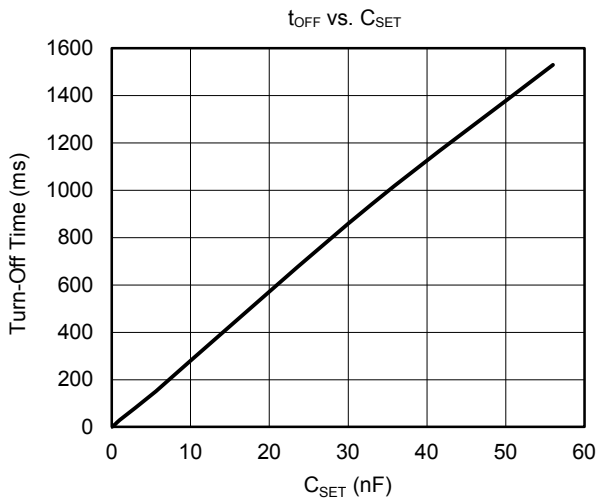
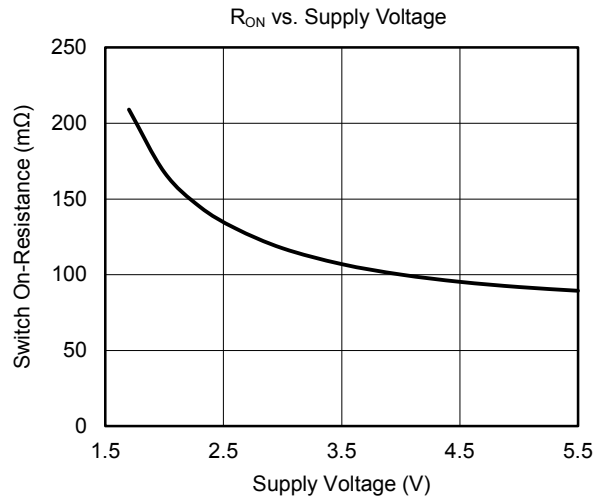
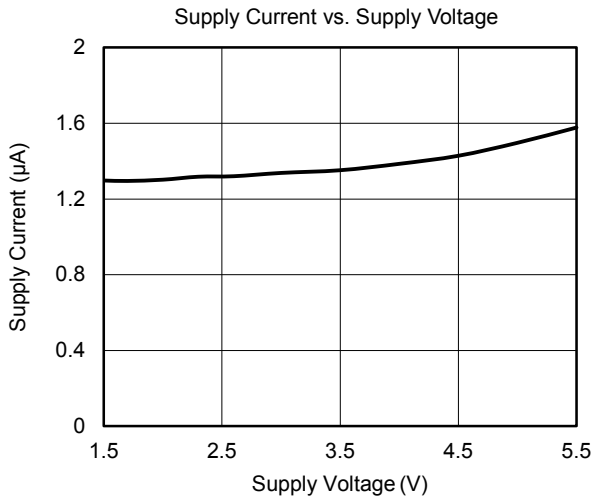

SYSTEM BLOCK DIAGRAM

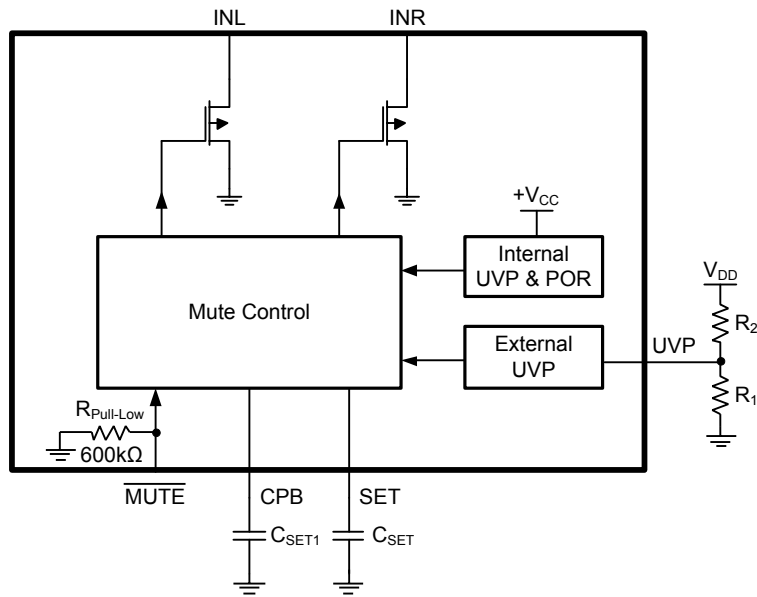

TIMING DIAGRAM

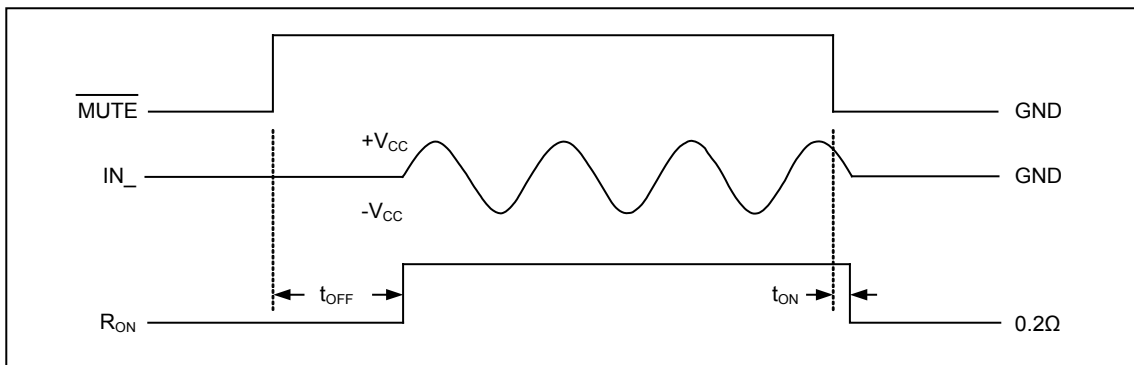

Figure 2. Turn-On/Off Time

**APPLICATION INFORMATION**

The SGM4807 is Click-Pop eliminator designed to be used with conventional line-out amplifiers. The SGM4807 works by adding a low-impedance current path from the line-out side of the DC-blocking capacitor to ground. Drive  $\overline{\text{MUTE}}$  pin low when turning off the amplifier, and high when enabling the amplifier. A short turn-on time allows the switches in the SGM4807 to close before the DC-blocking capacitors have significantly discharged, eliminating Clicks-Pops at amplifier turn-off. An adjustable turn-off time allows the delay to be set to mask all Clicks-Pops during amplifier turn-on.

SGM4807 has CPB and UVP pin to cancel the power-up and power-down Click-Pop noise.

**Setting the Turn-Off Time**

The SGM4807 features a SET pin input that allows the turn-off time to be adjusted from 1ms to 1000ms to match the Click-Pop profile of the amplifier startup. The value of an external capacitor sets the switch open delay, as shown in the following equation:

$$t_{\text{OFF}} \text{ (ms)} = 0.022 \times C_{\text{SET}} \text{ (pF)}$$

When the line-out amplifier is enabled, the SGM4807 automatically waits the set delay time before opening the analog switches. This allows amplifier turn-on Click-Pop to be eliminated.

**Selecting Series Resistors**

A series resistor ( $R_{\text{SERIES}}$ ), as shown in Figure 1, is necessary to achieve optimal Click-Pop reduction.

**Internal Under-Voltage Detection**

The SGM4807 can detect the under-voltage event happened on  $V_{\text{CC}}$  pin, if under-voltage event happens for  $V_{\text{CC}}$  power rail, SGM4807 will mute external audio signal.

**External Under-Voltage Detection**

In Figure 3, the SGM4807 contains an internal precision band-gap reference voltage and a comparator used to monitor the external  $V_{\text{DD}}$  supply voltage, if under-voltage event happens for  $V_{\text{DD}}$  power rail, SGM4807 will mute external audio signal.

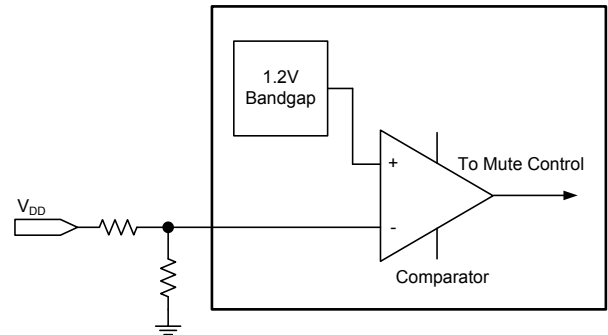

Figure 3. UVP Detection

**Click-Pop-Free Power Up**

Click-Pop-Free power up is ensured by keeping the  $\overline{\text{MUTE}}$  pin low before power-on blanking time is over. The chip should be kept in mute status until the input AC-coupling capacitors are fully charged, this way proper pre-charge of the AC-coupling is performed and pop-less power up is achieved. Figure 4 illustrates the preferred power-up sequence.

The power-on blanking time is adjustable. Adjust this time ( $t_{\text{PB}}$ ) by connecting a capacitor ( $C_{\text{PB}}$ ) between CPB pin and ground. Calculate the external capacitor as follows:

$$C_{\text{PB}} = (t_{\text{PB}}) / (5.2 \times 10^6)$$

where  $t_{\text{PB}}$  is in seconds and  $C_{\text{PB}}$  is in farads.

**Layout Considerations**

Bypass  $V_{\text{CC}}$  to GND with a 0.1 $\mu\text{F}$  capacitor. The 0.1 $\mu\text{F}$  bypass capacitor should be positioned as close as possible to  $V_{\text{CC}}$ . Minimize trace length from GND to solid system ground plane to ensure optimum performance.

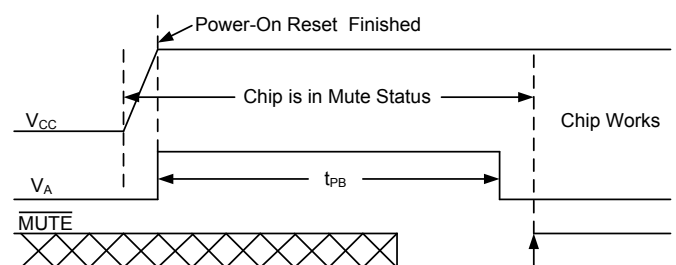
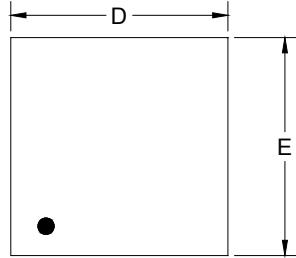

Figure 4. Power-Up Sequence to Cancel Click-Pop Noise



PACKAGE OUTLINE DIMENSIONS

TDFN-2x2-8L



TOP VIEW

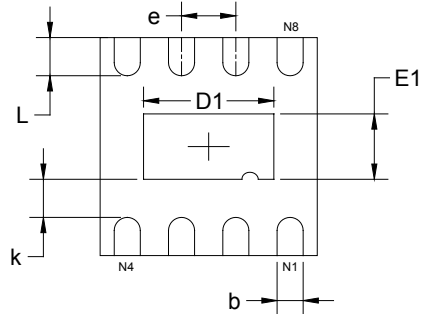

BOTTOM VIEW

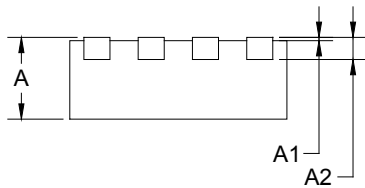

SIDE VIEW

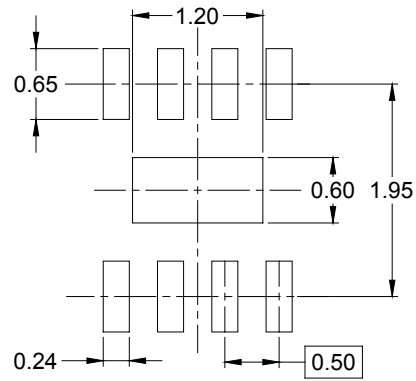

RECOMMENDED LAND PATTERN (Unit: mm)

Symbol	Dimensions In Millimeters		Dimensions In Inches	
	MIN	MAX	MIN	MAX
A	0.700	0.800	0.028	0.031
A1	0.000	0.050	0.000	0.002
A2	0.203 REF		0.008 REF	
D	1.900	2.100	0.075	0.083
D1	1.100	1.300	0.043	0.051
E	1.900	2.100	0.075	0.083
E1	0.500	0.700	0.020	0.028
k	0.200 MIN		0.008 MIN	
b	0.180	0.300	0.007	0.012
e	0.500 TYP		0.020 TYP	
L	0.250	0.450	0.010	0.018

PACKAGE OUTLINE DIMENSIONS

MSOP-8

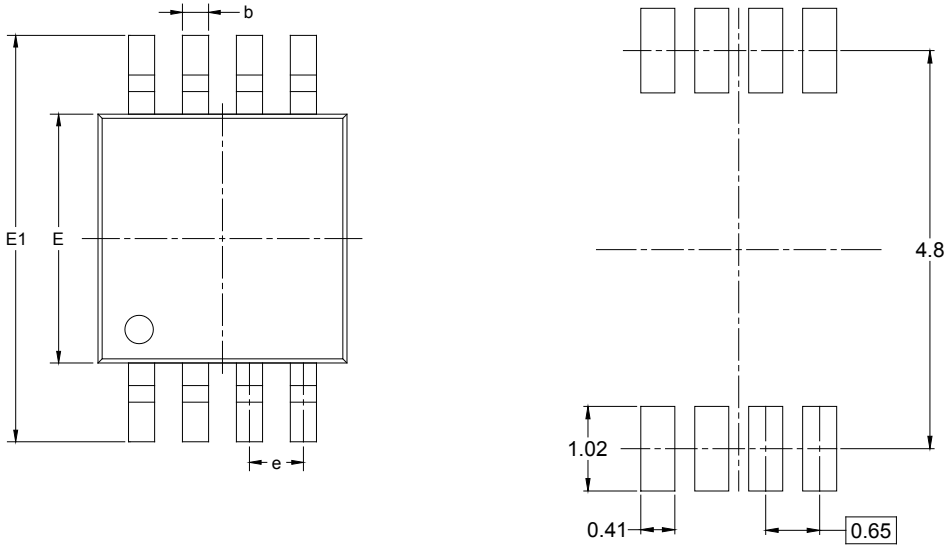

RECOMMENDED LAND PATTERN (Unit: mm)

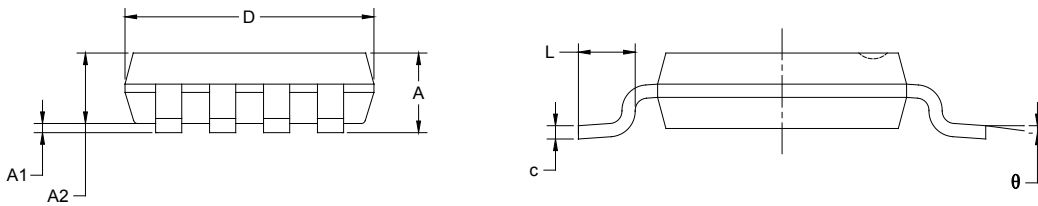

Symbol	Dimensions In Millimeters		Dimensions In Inches	
	MIN	MAX	MIN	MAX
A	0.820	1.100	0.032	0.043
A1	0.020	0.150	0.001	0.006
A2	0.750	0.950	0.030	0.037
b	0.250	0.380	0.010	0.015
c	0.090	0.230	0.004	0.009
D	2.900	3.100	0.114	0.122
E	2.900	3.100	0.114	0.122
E1	4.750	5.050	0.187	0.199
e	0.650 BSC		0.026 BSC	
L	0.400	0.800	0.016	0.031
θ	0°	6°	0°	6°

PACKAGE OUTLINE DIMENSIONS

WLCSP-1.57×0.80-8B

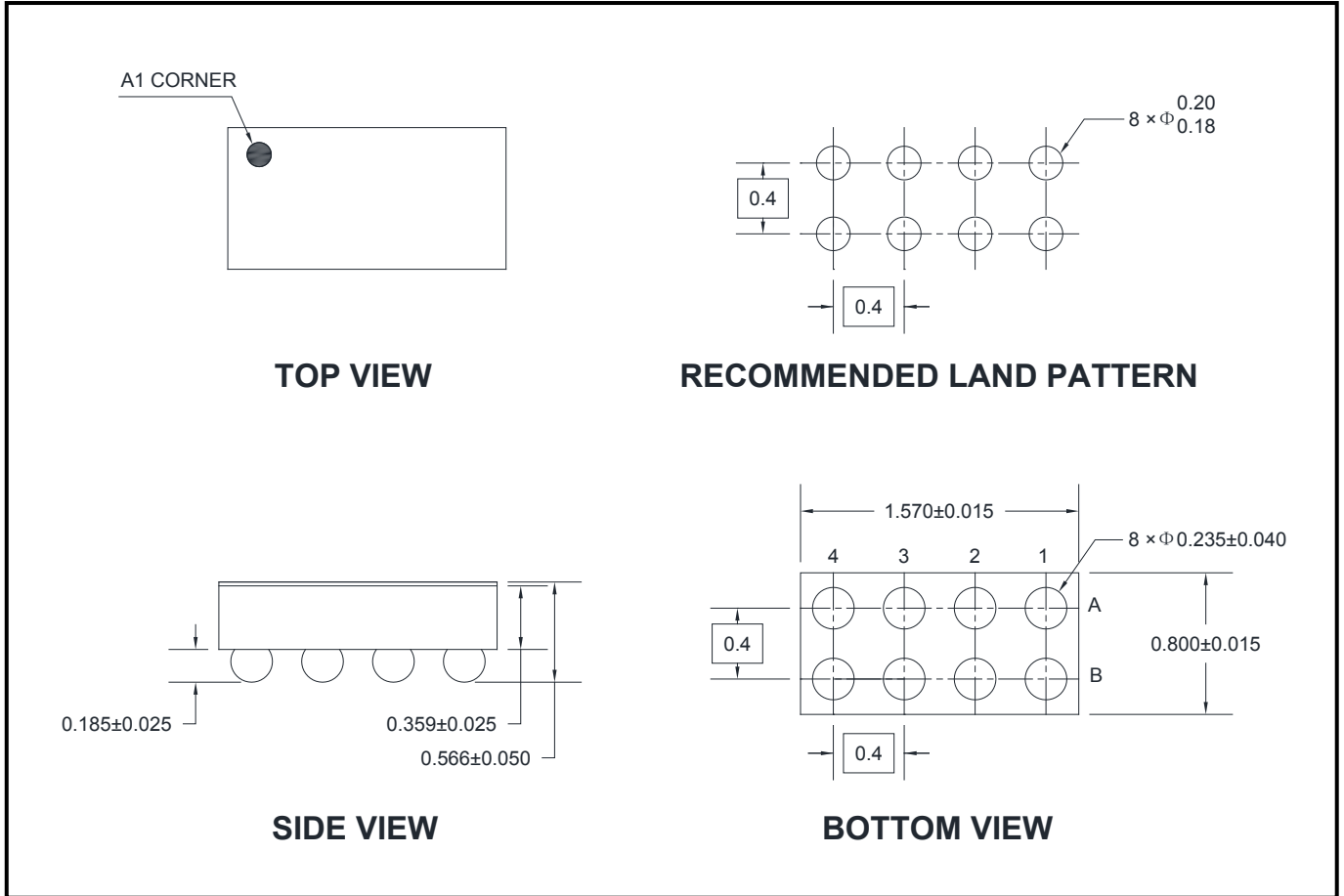

NOTE: All linear dimensions are in millimeters.

**TAPE AND REEL INFORMATION**

**REEL DIMENSIONS**

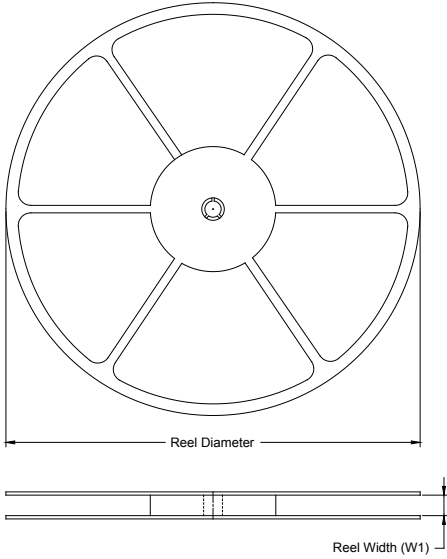

**TAPE DIMENSIONS**



NOTE: The picture is only for reference. Please make the object as the standard.

**KEY PARAMETER LIST OF TAPE AND REEL**

Package Type	Reel Diameter	Reel Width W1 (mm)	A0 (mm)	B0 (mm)	K0 (mm)	P0 (mm)	P1 (mm)	P2 (mm)	W (mm)	Pin1 Quadrant
TDFN-2x2-8L	7"	9.5	2.30	2.30	1.10	4.0	4.0	2.0	8.0	Q1
MSOP-8	13"	12.4	5.20	3.30	1.50	4.0	8.0	2.0	12.0	Q1
WLCSP-1.57x0.80-8B	7"	9.5	1.00	1.80	0.70	4.0	4.0	2.0	8.0	Q2

DD0001

# PACKAGE INFORMATION

## CARTON BOX DIMENSIONS



NOTE: The picture is only for reference. Please make the object as the standard.

## KEY PARAMETER LIST OF CARTON BOX

Reel Type	Length (mm)	Width (mm)	Height (mm)	Pizza/Carton
7" (Option)	368	227	224	8
7"	442	410	224	18
13"	386	280	370	5

DD0002