

系列号	HoCS
修订日期	2022-08-16
版本号	Ho-A0



Features

- 3 Watts power rating in 1 Watt size, 1225 package
- Low TCR of ± 100 PPM/ $^{\circ}$ C
- Resistance values from 1m to 1 ohm
- High purity alumina substrate for high power dissipation
- Long side terminations with higher power rating
- RoHS Compliance

Construction

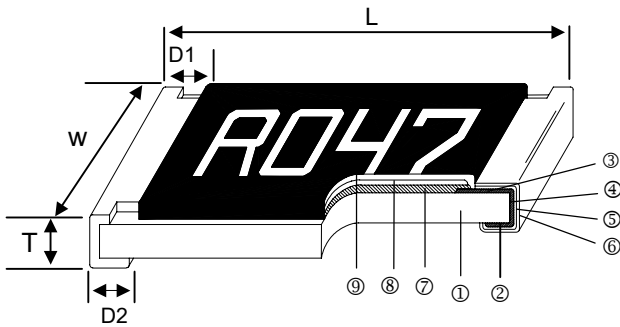

Applications

- Power Management Applications
- Switching Power Supply
- Over Current Protection in Audio Applications
- Voltage Regulation Module (VRM)
- DC-DC Converter, Battery Pack, Charger, Adaptor
- Automotive Engine Control
- Disk Driver

① Alumina Substrate	④ Edge Electrode	⑦ Resistor Layer
② Bottom Electrode	⑤ Barrier Layer	⑧ Primary Overcoat
③ Top Electrode	⑥ External Electrode	⑨ Secondary Overcoat

Dimensions

Type	Size (Inch)	L (mm)	W (mm)	T (mm)	D1 (mm)	D2 (mm)	Weight (g) (1000pcs)
CS	1210	3.10 \pm 0.10	2.60 \pm 0.15	0.55 \pm 0.10	0.50 \pm 0.30	0.50 \pm 0.25	15.5

Part Numbering

Ho	CS	1210	150mR	1%	TCR200
↓	↓	↓	↓	↓	↓
制造商	产品类别	封装	阻值	精度	温度系数
毫欧电子	贴片陶瓷	1210	10mR~1000mR	D= \pm 0.5% F= \pm 1% G= \pm 2% J= \pm 5%	F= \pm 200 G= \pm 300 H= \pm 400 J= \pm 600



地址：深圳市龙华新区观澜大布头路南通邦高新产业园 A 栋 8 楼

Recommend Land Pattern

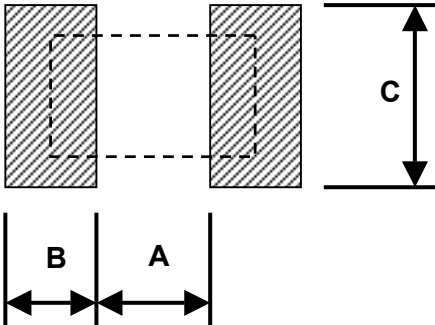

Type	A (mm)	B (mm)	C (mm)
CS1210	2.00	1.15	2.50±0.2

Derating Curve

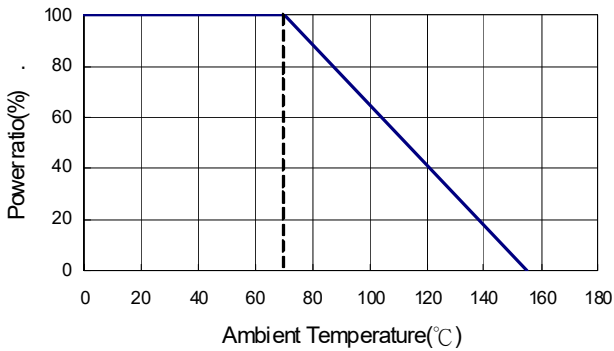

Soldering Condition

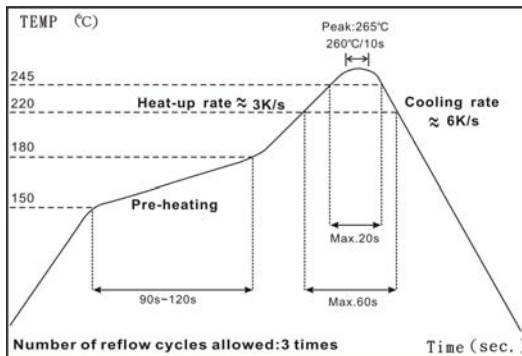

IR Reflow Soldering

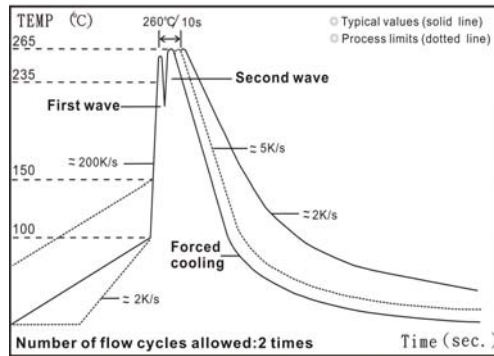

Wave Soldering (Flow Soldering)

- (1) Time of IR reflow soldering at maximum temperature point 260°C : 10s
- (2) Time of wave soldering at maximum temperature point 260°C : 10s
- (3) Time of soldering iron at maximum temperature point 410°C : 5s

 毫欧电阻 毫欧制造	HoCS1210贴片陶瓷系列规格书	系列号	HoCS
		修订日期	2022-08-16
		版本号	Ho-A0

Standard Electrical Specifications

Type \ Item	Power Rating at 70°C	Operating Temp. Range	Max. Operating Current	Resistance Range (mΩ)				TCR (PPM/°C)
				±0.5%	±1%	±2%	±5%	
CS1210	1/2W	-55 ~ +155°C	5.00A	10 - 20	21 - 50	51 - 91	100 - 1000	±600 ±400 ±300 ±200
			7.07A					
			8.66A					
			10.0A					

Low TCR Electrical Specifications

Type \ Item	Power Rating at 70°C	Operating Temp. Range	Max. Operating Current	Resistance Range (mΩ)				TCR (PPM/°C)
				±0.5%	±1%	±2%	±5%	
CS1210	1/2W	-55 ~ +155°C	2.58A	75 - 1000				±100

Operating Current= $\sqrt{P/R}$

地址：深圳市龙华新区观澜大布头路南通邦高新产业园 A 栋 8 楼

深圳市毫欧电子有限公司 | 电话：0755-28153546 | 传真：0755-22630181 | 网址：www.moolee.com.cn



HoCS1210贴片陶瓷系列规格书

系列号	HoCS
修订日期	2022-08-16
版本号	Ho-A0

Environmental Characteristics

Item	Requirement	Test Method
Temperature Coefficient of Resistance (T.C.R.)	As Spec.	JIS-C-5201-1 4.8 IEC-60115-1 4.8 -55°C~+125°C, 25°C is the reference temperature
Short Time Overload	±(0.5%+0.05Ω)	JIS C 5201-1 4.13 IEC 60115-1 4.13 RCWV*2.5 or Max. Overload Voltage whichever is lower for 5 seconds
	±(1.0%+0.05Ω) For High power rating	
Insulation Resistance	≥ 10G	JIS-C-5201-1 4.6 IEC-60115-1 4.6 Max. Overload Voltage for 1 minute
Endurance	±(1.0%+0.05Ω)	JIS-C-5201-1 4.25 IEC-60115-1 4.25.1 70±2°C, RCWV for 1000 hrs with 1.5 hrs "ON" and 0.5 hr "OFF"
Damp Heat with Load	±(0.5%+0.05Ω)	JIS-C-5201-1 4.24 IEC-60115-1 4.24 40±2°C, 90~95% R.H., RCWV for 1000 hrs with 1.5 hrs "ON" and 0.5 hr "OFF"
Dry Heat	±(0.5%+0.05Ω)	JIS-C-5201-1 4.23 IEC-60115-1 4.23.2 at +155°C for 1000 hrs
Bending Strength	±(1.0%+0.05Ω)	JIS-C-5201-1 4.33 IEC-60115-1 4.33 Bending once for 5 seconds with 3mm 2010, 2512 sizes: 2mm
Solderability	95% min. coverage	JIS-C-5201-1 4.17 IEC-60115-1 4.17 245±5°C for 3 seconds
Resistance to Soldering Heat	±(0.5%+0.05Ω)	JIS-C-5201-1 4.18 IEC-60115-1 4.18 260±5°C for 10 seconds
Voltage Proof	No breakdown or flashover	JIS-C-5201-1 4.7 IEC-60115-1 4.7 1.42 times Max. Operating Voltage for 1 minute
Leaching	Individual leaching area ≤5% Total leaching area ≤10%	JIS-C-5201-1 4.18 IEC-60068-2-58 8.2.1 260±5°C for 30 seconds
Rapid Change of Temperature	±(0.5%+0.05Ω)	JIS-C-5201-1 4.19 IEC-60115-1 4.19 -55°C to +155°C, 5 cycles

RCWV(Rated Continuous Working Voltage)= $\sqrt{P \cdot R}$ or Max. Operating Voltage whichever is lower.

Storage Temperature: 15~28°C; Humidity < 80%RH

地址：深圳市龙华新区观澜大布头路南通邦高新产业园 A 栋 8 楼

深圳市毫欧电子有限公司 | 电话：0755-28153546 | 传真：0755-22630181 | 网址：www.moolee.com.cn

■Packaging

Packaging Quantity & Reel Specifications

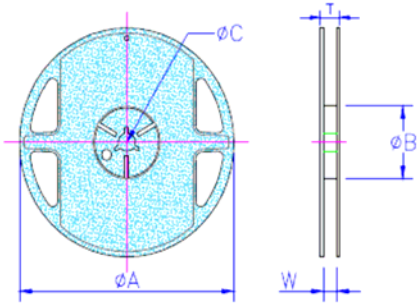

Type	ΦA (mm)	ΦB (mm)	ΦC (mm)	W (mm)	T (mm)	Paper Tape (EA)	Embossed Plastic Tape (EA)
CS1210	178.0±1.0	60.0+1.0	13.5±0.7	9.5±0.1	11.5±1.0	5,000	

Paper Tape Specifications

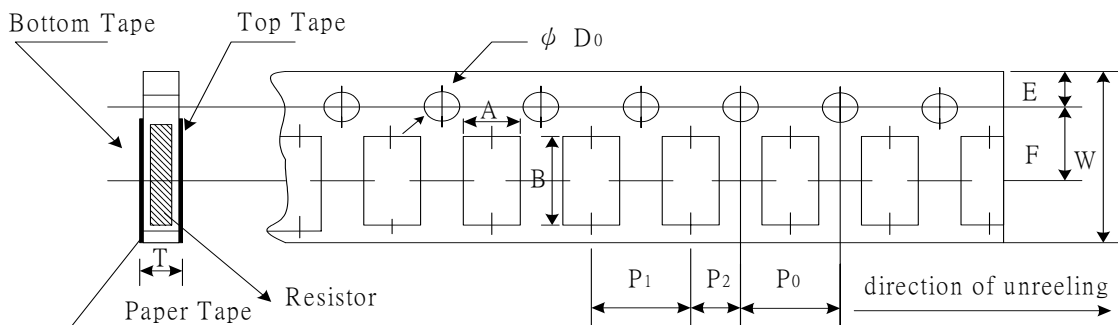

Type	A (mm)	B (mm)	W (mm)	E (mm)	F (mm)	P0 (mm)	P1 (mm)	P2 (mm)	ΦD ₀ (mm)	T (mm)
CS1210	2.90±0.10	3.50±0.20	8.0±0.20	1.75±0.10	3.50±0.05	4.00±0.10	4.00±0.05	2.00±0.05	1.50+0.1,-0	0.85±0.10