





**REVISED RECORD SHEET**

REV. NO	REV. DATE	REVISED CONTENT



<b>INDEX</b>	<b>Page</b>
■ Part Number Code	1
■ Structure and Dimensions	2
■ Electrical Characteristics	2
■ Reliability	3
■ Soldering Recommendation	4
■ Max. Power Dissipation Derating Curve	5
■ RoHS Compliant Declaration	5
■ Warehouse Storage Conditions of Products	5
■ Install and use&Storage place condition&Warn and note item	6
■ Taping and Dimensions	7
■ Standard Packing	8
■ Safety Approvals	9
■ Certificates	9
■ R-T Table	10~14



Part Number Code

Example :

**TTC**    **3**    **A**    **104**    **F**    **419**    **3**    **F**    **Y10**  
**(1)**    **(2)**    **(3)**    **(4)**    **(5)**    **(6)**    **(7)**    **(8)**    **(9)**

No.	Item	Digit	Specification
(1)	Product Type	TTC	Thinking NTC thermistor TTC type
(2)	Body Size	3	Φ4 mm x H 5.0 mm (max.)
(3)	Definition of B Value	A	B <sub>25/85</sub>
(4)	Zero Power Resistance at 25°C	104	10 x 10 <sup>4</sup> Ω = 100 KΩ
(5)	Tolerance of R <sub>25°C</sub>	F	± 1%
(6)	B Value	419	4190K
(7)	Tolerance of B Value	3	±3%
(8)	Appearance	F	Out kink lead epoxy coating (Green)
(9)	Optional Suffix	Y10	RoHS+HF compliance Taping 12.7mm&Box

Structure and Dimensions

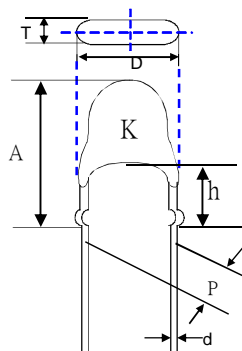

(unit:mm)

Item	D	d	P	A	T	h
Max	4	0.52	3.04	13.5	3	7
Min	2	0.48	2.04	---	1.5	5

Electrical Characteristics

Part No.	Zero Power Resistance at 25°C	Tolerance of R <sub>25°C</sub>	B <sub>25/85</sub> Value	Tolerance of B Value	Max. Power Dissipation at 25°C	Dissipation Factor	Thermal Time Constant	Operating Temperature Range
	R <sub>25°C</sub> (KΩ)	(± %)	(K)	(± %)	P <sub>max</sub> (mW)	δ(mW/°C)	τ (sec.)	T <sub>L</sub> ~T <sub>U</sub> (°C)
TTC3A104F4193FY10	100	1	4190	3	150	≥2.5	≤18	-40 ~+125

Reliability

Item	Standard	Test conditions / Methods	Specifications															
Tensile Strength of Terminals	IEC60068-2-21	<p>Gradually applying the force specified and keeping the unit fixed for 10±1 sec.</p> <table style="width: 100%; border: none;"> <tr> <td style="text-align: center; border: none;">Terminal diameter (mm)</td> <td style="text-align: center; border: none;">Force (Kg)</td> </tr> <tr> <td style="text-align: center; border: none;"><u>0.3&lt;d≤0.5</u></td> <td style="text-align: center; border: none;"><u>0.5</u></td> </tr> <tr> <td style="text-align: center; border: none;">0.5&lt;d≤0.8</td> <td style="text-align: center; border: none;">1.0</td> </tr> </table>	Terminal diameter (mm)	Force (Kg)	<u>0.3&lt;d≤0.5</u>	<u>0.5</u>	0.5<d≤0.8	1.0	No visible damage									
Terminal diameter (mm)	Force (Kg)																	
<u>0.3&lt;d≤0.5</u>	<u>0.5</u>																	
0.5<d≤0.8	1.0																	
Bending Strength of Terminals	IEC60068-2-21	<p>Hold specimen and apply the force specified below to each lead. Bend the specimen to 90°, then return to the original position. Repeat the procedure in the opposite direction.</p> <table style="width: 100%; border: none;"> <tr> <td style="text-align: center; border: none;">Terminal diameter (mm)</td> <td style="text-align: center; border: none;">Force (Kg)</td> </tr> <tr> <td style="text-align: center; border: none;"><u>0.3&lt;d≤0.5</u></td> <td style="text-align: center; border: none;"><u>0.25</u></td> </tr> <tr> <td style="text-align: center; border: none;">0.5&lt;d≤0.8</td> <td style="text-align: center; border: none;">0.50</td> </tr> </table>	Terminal diameter (mm)	Force (Kg)	<u>0.3&lt;d≤0.5</u>	<u>0.25</u>	0.5<d≤0.8	0.50	No visible damage									
Terminal diameter (mm)	Force (Kg)																	
<u>0.3&lt;d≤0.5</u>	<u>0.25</u>																	
0.5<d≤0.8	0.50																	
Solderability	IEC60068-2-20	245 ± 3 °C , 3 ± 0.3 sec	At least 95% of terminal electrode is covered by new solder															
Resistance to Soldering Heat	IEC60068-2-20	260 ± 3 °C , 10 ± 1 sec	No visible damage   ΔR <sub>25</sub> /R <sub>25</sub>   ≤ 3 %															
High Temperature Storage	IEC60068-2-2	125 ± 5 °C , 1000 ± 24 hrs	No visible damage   ΔR <sub>25</sub> /R <sub>25</sub>   ≤ 5 %															
Damp Heat, Steady State	IEC 60068-2-78	40 ± 2 °C , 90 ~ 95 % RH , 1000 ± 24 hrs	No visible damage   ΔR <sub>25</sub> /R <sub>25</sub>   ≤ 3 %															
Rapid Change of Temperature	IEC60068-2-14	<p>The conditions shown below shall be repeated 5 cycles</p> <table border="1" style="width: 100%; border-collapse: collapse;"> <thead> <tr> <th>Step</th> <th>Temperature (°C)</th> <th>Period (minutes)</th> </tr> </thead> <tbody> <tr> <td style="text-align: center;">1</td> <td style="text-align: center;">-40 ± 5</td> <td style="text-align: center;">30 ± 3</td> </tr> <tr> <td style="text-align: center;">2</td> <td style="text-align: center;">Room temperature</td> <td style="text-align: center;">5 ± 3</td> </tr> <tr> <td style="text-align: center;">3</td> <td style="text-align: center;">125 ± 5</td> <td style="text-align: center;">30 ± 3</td> </tr> <tr> <td style="text-align: center;">4</td> <td style="text-align: center;">Room temperature</td> <td style="text-align: center;">5 ± 3</td> </tr> </tbody> </table>	Step	Temperature (°C)	Period (minutes)	1	-40 ± 5	30 ± 3	2	Room temperature	5 ± 3	3	125 ± 5	30 ± 3	4	Room temperature	5 ± 3	No visible damage   ΔR <sub>25</sub> /R <sub>25</sub>   ≤ 3 %
Step	Temperature (°C)	Period (minutes)																
1	-40 ± 5	30 ± 3																
2	Room temperature	5 ± 3																
3	125 ± 5	30 ± 3																
4	Room temperature	5 ± 3																
Max. Power Dissipation	IEC60539-1 4.26.3	25 ± 5 °C , Pmax. , 1000 ±24 hrs	No visible damage   ΔR <sub>25</sub> /R <sub>25</sub>   ≤ 5 %															
Dissipation Factor (δ)	Specification	<p>Dissipation factor is ration of thermistor's temperature change caused by its dissipation power under specific ambienttemperature. which stands for dissipation power for thermistor's increase of 1°C.</p> $\delta = V^2 / (T_2 - T_1) \text{ (mW/°C)}$	≥ 2.5mW/°C															
Thermal Time Constant( τ )	Specification	The thermal time constant is a 63.2% change of thermistor's body temperature from its initial temperature (T0) to specific temperature (T1) under zero-power conditions.	≤ 18Sec															

## Soldering Recommendation

### Wave Soldering Profile

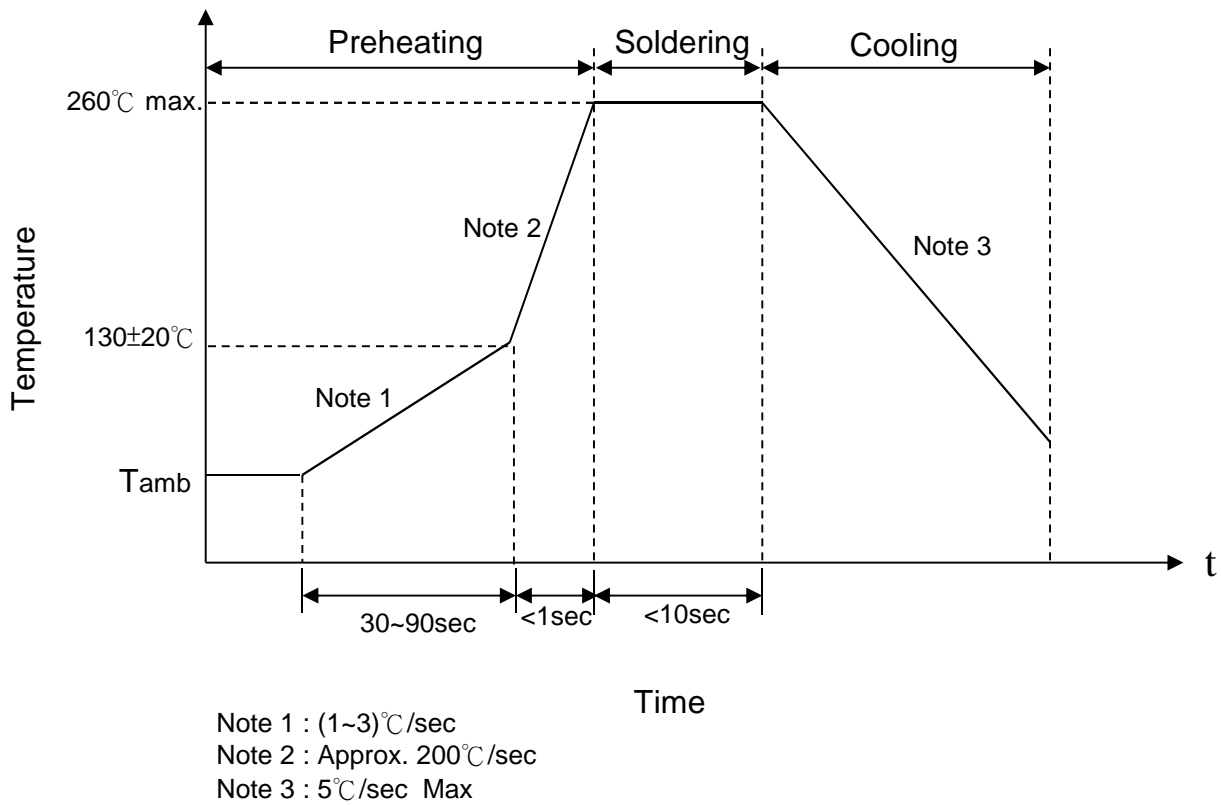

Caution: It has be better to keep the minimum distance as 6mm between the bottom of the thermistorbody and PCB surface to prevent component damage.

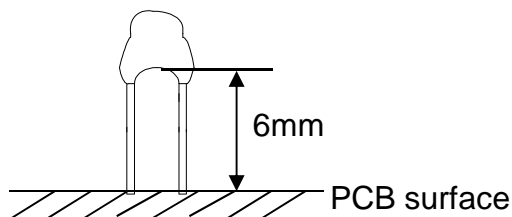

### Recommended Reworking Conditions with Soldering Iron

Item	Conditions
Temperature of Soldering Iron-tip	$360^{\circ}\text{C}$ (max.)
Soldering Time	3 sec (max.)
Distance from Thermistor	6 mm (min.)

### Max. Power Dissipation Derating Curve

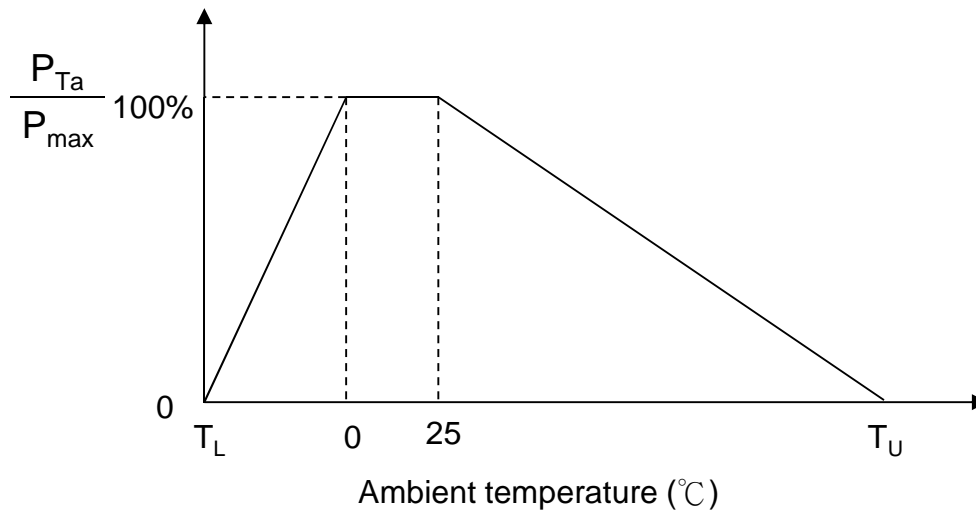

Note:  $T_L$  = Minimum operating temperature ( $^{\circ}\text{C}$ )

$T_U$  = Maximum operating temperature ( $^{\circ}\text{C}$ )

For example :

Ambient temperature( $T_a$ )=55 $^{\circ}\text{C}$

Maximum operating temperature( $T_u$ )=125 $^{\circ}\text{C}$

$P_{Ta} = (T_u - T_a) / (T_u - 25) \times P_{max} = 70\% P_{max}$

### RoHS Compliant Declaration

We hereby declare that the components delivered to your company are compliant with RoHS directive 2015/863/EU.

### Warehouse Storage Conditions of Products

(I) Storage Conditions :

- 1.Storage Temperature : -10 $^{\circ}\text{C}$  ~+40 $^{\circ}\text{C}$
- 2.Relative Humidity :  $\leq 75\% \text{RH}$ (not dewing condition)
- 3.Keep away from corrosive atmosphere and sunlight

(II) Period of Storage : 1 year



### **Install and use**

1. Use this product within the specified temperature range.
2. Higher temperature may cause deterioration of the characteristics or the material quality of this product.
3. Do not melt the solder in resin head, when you solder this product. If you melt the solder in resin head, it has possibility that the break of wire, short and insulation damage.
4. Do not touch the resin head directly by solder iron. It may cause the melt of solder in resin head.
5. At least away from resin head 10mm above when lead dividing.
6. In case you cut the lead wire of this product less than 10mm from resin head, the heat of melted solder at lead wire edge is propagated easily to the resin head along the lead wire.
7. Radius of lead bending should be more than 2mm when lead bending.  
Holding element by side lead wire is recommended when lead wire is bent or cut.
8. Do not apply an excessive force to the lead. Otherwise, it may cause junction between lead and element to break or crack.
9. The ceramic element of this product is fragile, and care must be taken not to load an excessive press-force or not to give a shock at handling. Such forces may cause cracking or chipping.
10. If you mold by resin this product, please evaluate the quality of this product before you use it.

### **Storage place condition**

To keep solderability of product from declining, the following storage condition is recommended.

1. Storage condition:  
Temperature -10°C to +40°C  
Humidity less than 75%RH (not dewing condition)
2. Storage term:  
Use this product within 1 year after delivery by first-in and first-out stocking system.
3. Handling after unpacking:  
After unpacking, reseal product promptly or store it in a sealed container with a drying agent.
4. Storage place:  
Do not store this product in corrosive gas (Sulfuric acid gas, Chlorine gas, etc.) or in direct sunlight.

### **Warn and note item**

This product is designed for application in an ordinary environment (normal room temperature, humidity and atmospheric pressure).

Do not use under the following conditions because all of these factors can deteriorate the product characteristics or cause failures and burn-out.

1. Corrosive gas or deoxidizing gas (Chlorine gas, Hydrogen sulfide gas, Ammonia gas, Sulfuric acid gas, Nitric oxide gas, etc.)
2. Volatile or flammable gas
3. Dusty conditions
4. Under vacuum, or under high or low pressure
5. Wet or humid locations; soak in the liquid or wash with liquid
6. Places with salt water, oils, chemical liquids or organic solvents and do not use directly with quick-drying glue.
7. Strong vibrations
8. Other places where similar hazardous conditions exist
9. Be sure to provide an appropriate fail-safe function on your product to prevent secondary damages that may be caused by the abnormal function or the failure of our product.
10. This series is manufactured and promoted for applying in general electronics devices such as audio-video equipment, home electric appliance, office automation equipment, communication equipment, power module, LED lighting, measurement hardware, machine accessory, etc.
11. This series cannot be applied in area like automotive product, military, aerospace, etc. except general electronic device, Thinking shall not be held liable for any malfunction or breakdown caused by using product in the condition which is inconsistent with that recommended by Thinking.

Taping and Dimensions

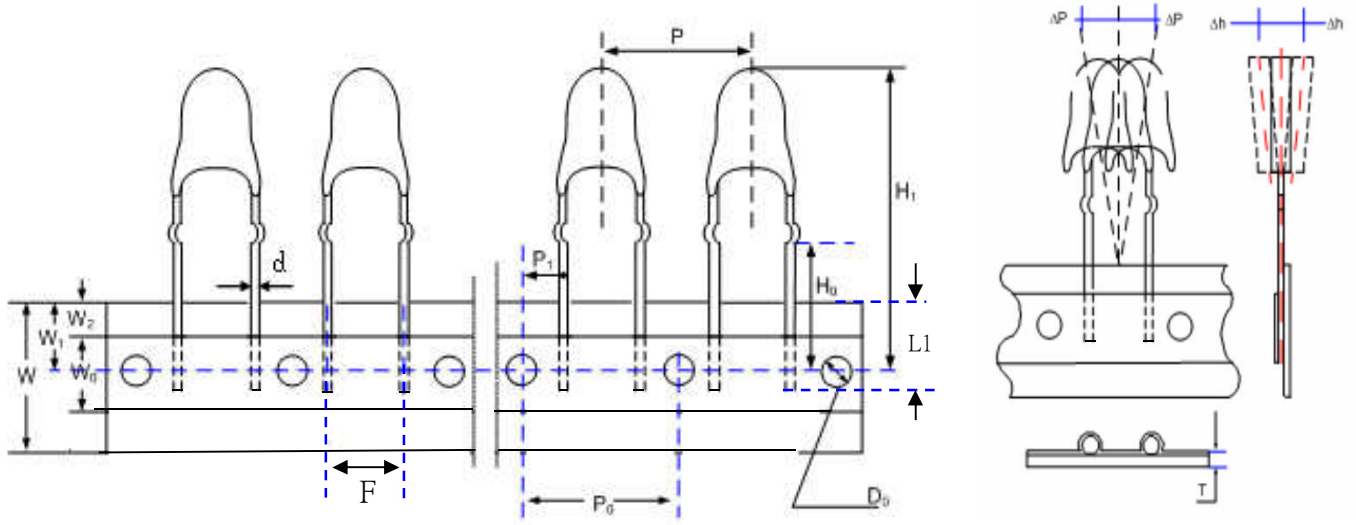

(Unit:mm)

Item	P0	F	P	P1	H0	H1	d	W0	W1	W2	W	ΔP	Δh	L1	D0	T
	±0.3	±0.5	±1	±0.7	±0.5	Max	±0.02	±1.5	+0.75 /-0.5	Max	+1 /-0.5	Max	Max.	±1	±0.2	Max
	12.7	2.54	12.7	5.08	17	31	0.5	12	9	3	18	1	2	10	4	0.6

Standard Packing

(1) Quantity (2500pcs / Ammo box)

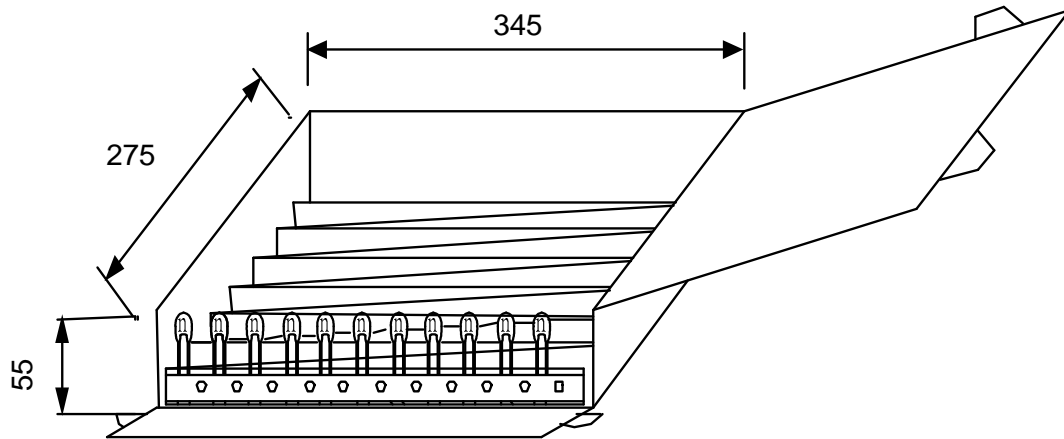

(Unit:mm)

(2) : Quantity (5 boxes /Carton)

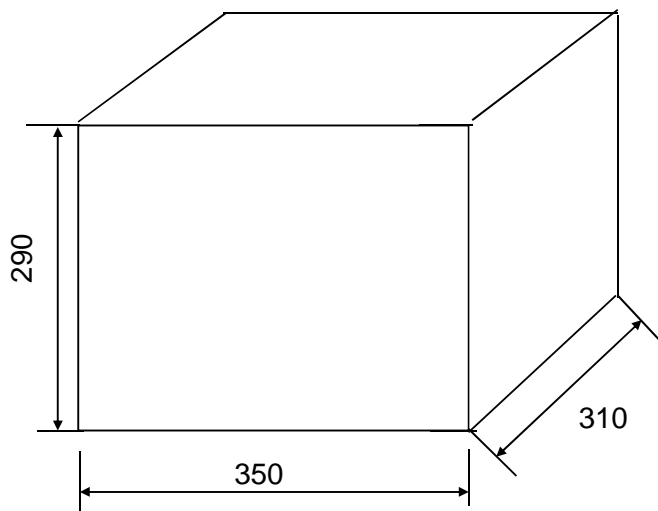

(Unit:mm)

Safety Approvals (Certified Model/Type : TTC03-104)



\* UL 1434 / cUL recognized (File # E138827)



\* CQC GB/T 6663.1-2007 recognized (File# CQC04001011945)

\* CQC GB 6663-86 recognized (File# CQC04001011966)



\* TÜV recognized (File # R 50050155)

Certificates

- (1) IATF 16949 certificate
- (2) ISO 9001 certificate

Test Report

- (1) RoHS test report
- (2) Halogen-free test report

R - T Table

Part No. : TTC3A104F4193FY10

R25=100KOhm  $\pm$ 1%B25/85 = 4190 K  $\pm$  3%

Temperature (°C)	Rmax. (K $\Omega$ )	Rnor. (K $\Omega$ )	Rmin. (K $\Omega$ )	Temperature Tol. (°C)		Resistance Tol. (%)	
-40	3494.28	3120.40	2786.24	-1.99	1.90	12.0%	-10.7%
-39	3291.93	2944.81	2634.03	-1.98	1.89	11.8%	-10.6%
-38	3102.36	2780.03	2490.94	-1.96	1.86	11.6%	-10.4%
-37	2923.93	2624.66	2355.79	-1.93	1.83	11.4%	-10.2%
-36	2755.44	2477.70	2227.73	-1.89	1.79	11.2%	-10.1%
-35	2596.03	2338.41	2106.15	-1.85	1.76	11.0%	-9.9%
-34	2445.08	2206.28	1990.61	-1.81	1.72	10.8%	-9.8%
-33	2302.10	2080.92	1880.80	-1.76	1.68	10.6%	-9.6%
-32	2166.74	1962.02	1776.47	-1.72	1.65	10.4%	-9.5%
-31	2038.70	1849.36	1677.43	-1.68	1.61	10.2%	-9.3%
-30	1917.72	1742.72	1583.53	-1.64	1.58	10.0%	-9.1%
-29	1803.56	1641.90	1494.59	-1.60	1.55	9.8%	-9.0%
-28	1695.96	1546.72	1410.48	-1.57	1.52	9.6%	-8.8%
-27	1594.70	1456.98	1331.02	-1.53	1.49	9.5%	-8.6%
-26	1499.50	1372.46	1256.06	-1.50	1.46	9.3%	-8.5%
-25	1410.11	1292.96	1185.42	-1.47	1.44	9.1%	-8.3%
-24	1326.26	1218.25	1118.92	-1.45	1.42	8.9%	-8.2%
-23	1247.67	1148.10	1056.37	-1.42	1.39	8.7%	-8.0%
-22	1174.06	1082.28	997.573	-1.39	1.37	8.5%	-7.8%
-21	1105.16	1020.56	942.341	-1.37	1.35	8.3%	-7.7%
-20	1040.68	962.702	890.477	-1.35	1.33	8.1%	-7.5%
-19	980.364	908.482	841.787	-1.33	1.31	7.9%	-7.3%
-18	923.941	857.676	796.084	-1.30	1.29	7.7%	-7.2%
-17	871.160	810.067	753.183	-1.28	1.27	7.5%	-7.0%
-16	821.780	765.450	712.909	-1.26	1.26	7.4%	-6.9%
-15	775.569	723.625	675.092	-1.24	1.24	7.2%	-6.7%
-14	732.308	684.405	639.571	-1.22	1.22	7.0%	-6.6%
-13	691.794	647.613	606.194	-1.20	1.20	6.8%	-6.4%
-12	653.831	613.082	574.815	-1.18	1.18	6.6%	-6.2%
-11	618.241	580.656	545.302	-1.16	1.16	6.5%	-6.1%
-10	584.856	550.189	517.526	-1.14	1.14	6.3%	-5.9%
-9	553.519	521.545	491.370	-1.12	1.12	6.1%	-5.8%
-8	524.085	494.599	466.724	-1.09	1.10	6.0%	-5.6%
-7	496.422	469.232	443.487	-1.07	1.08	5.8%	-5.5%
-6	470.404	445.338	421.564	-1.05	1.06	5.6%	-5.3%
-5	445.919	422.815	400.868	-1.03	1.03	5.5%	-5.2%
-4	422.861	401.572	381.317	-1.00	1.01	5.3%	-5.0%
-3	401.133	381.524	362.837	-0.98	0.99	5.1%	-4.9%
-2	380.646	362.592	345.359	-0.95	0.96	5.0%	-4.8%
-1	361.318	344.703	328.819	-0.93	0.94	4.8%	-4.6%



R - T Table

Part No. : TTC3A104F4193FY10

R25=100KOhm ±1%

B25/85 = 4190 K ± 3%

Temperature (°C)	Rmax. (KΩ)	Rnor. (KΩ)	Rmin. (KΩ)	Temperature Tol. (°C)		Resistance Tol. (%)	
0	343.072	327.790	313.158	-0.90	0.91	4.7%	-4.5%
1	325.839	311.793	298.322	-0.88	0.89	4.5%	-4.3%
2	309.555	296.653	284.261	-0.85	0.86	4.3%	-4.2%
3	294.160	282.319	270.927	-0.83	0.84	4.2%	-4.0%
4	279.599	268.741	258.279	-0.80	0.81	4.0%	-3.9%
5	265.821	255.874	246.276	-0.77	0.79	3.9%	-3.8%
6	252.779	243.677	234.880	-0.75	0.76	3.7%	-3.6%
7	240.430	232.111	224.058	-0.72	0.73	3.6%	-3.5%
8	228.732	221.139	213.777	-0.69	0.71	3.4%	-3.3%
9	217.649	210.729	204.008	-0.66	0.68	3.3%	-3.2%
10	207.145	200.848	194.722	-0.64	0.65	3.1%	-3.0%
11	197.187	191.467	185.895	-0.61	0.63	3.0%	-2.9%
12	187.745	182.560	177.500	-0.58	0.60	2.8%	-2.8%
13	178.790	174.100	169.515	-0.55	0.57	2.7%	-2.6%
14	170.295	166.063	161.920	-0.53	0.54	2.5%	-2.5%
15	162.236	158.427	154.693	-0.50	0.51	2.4%	-2.4%
16	154.588	151.171	147.816	-0.47	0.49	2.3%	-2.2%
17	147.329	144.275	141.270	-0.44	0.46	2.1%	-2.1%
18	140.438	137.719	135.039	-0.41	0.43	2.0%	-1.9%
19	133.897	131.487	129.107	-0.39	0.40	1.8%	-1.8%
20	127.685	125.561	123.459	-0.36	0.37	1.7%	-1.7%
21	121.786	119.925	118.080	-0.33	0.34	1.6%	-1.5%
22	116.184	114.565	112.958	-0.30	0.32	1.4%	-1.4%
23	110.861	109.466	108.078	-0.27	0.29	1.3%	-1.3%
24	105.805	104.616	103.429	-0.25	0.26	1.1%	-1.1%
25	101.000	100.000	99.0000	-0.22	0.23	1.0%	-1.0%
26	96.6940	95.6077	94.5242	-0.25	0.26	1.1%	-1.1%
27	92.5901	91.4272	90.2699	-0.28	0.29	1.3%	-1.3%
28	88.6783	87.4477	86.2256	-0.31	0.32	1.4%	-1.4%
29	84.9491	83.6590	82.3803	-0.34	0.35	1.5%	-1.5%
30	81.3933	80.0512	78.7235	-0.37	0.39	1.7%	-1.7%
31	78.0023	76.6153	75.2455	-0.40	0.42	1.8%	-1.8%
32	74.7681	73.3425	71.9368	-0.44	0.45	1.9%	-1.9%
33	71.6827	70.2244	68.7888	-0.47	0.48	2.1%	-2.0%
34	68.7389	67.2532	65.7930	-0.50	0.52	2.2%	-2.2%
35	65.9297	64.4215	62.9414	-0.53	0.55	2.3%	-2.3%
36	63.2483	61.7221	60.2267	-0.57	0.58	2.5%	-2.4%
37	60.6886	59.1485	57.6418	-0.60	0.61	2.6%	-2.5%
38	58.2444	56.6942	55.1798	-0.63	0.65	2.7%	-2.7%
39	55.9101	54.3532	52.8345	-0.67	0.68	2.9%	-2.8%



R - T Table

Part No. : TTC3A104F4193FY10

R25=100KOhm ±1%

B25/85 = 4190 K ± 3%

Temperature (°C)	Rmax. (KΩ)	Rnor. (KΩ)	Rmin. (KΩ)	Temperature Tol.		Resistance Tol.	
				(°C)		(%)	
40	53.6803	52.1199	50.5998	-0.70	0.71	3.0%	-2.9%
41	51.5499	49.9888	48.4701	-0.73	0.75	3.1%	-3.0%
42	49.5140	47.9547	46.4399	-0.77	0.78	3.3%	-3.2%
43	47.5680	46.0129	44.5042	-0.80	0.81	3.4%	-3.3%
44	45.7075	44.1588	42.6582	-0.84	0.85	3.5%	-3.4%
45	43.9284	42.3879	40.8973	-0.87	0.88	3.6%	-3.5%
46	42.2268	40.6962	39.2171	-0.90	0.92	3.8%	-3.6%
47	40.5989	39.0797	37.6136	-0.94	0.95	3.9%	-3.8%
48	39.0411	37.5347	36.0829	-0.98	0.98	4.0%	-3.9%
49	37.5501	36.0578	34.6214	-1.01	1.02	4.1%	-4.0%
50	36.1228	34.6457	33.2257	-1.05	1.05	4.3%	-4.1%
51	34.7560	33.2951	31.8924	-1.08	1.09	4.4%	-4.2%
52	33.4470	32.0031	30.6184	-1.12	1.12	4.5%	-4.3%
53	32.1930	30.7668	29.4009	-1.15	1.15	4.6%	-4.4%
54	30.9915	29.5837	28.2370	-1.19	1.19	4.8%	-4.6%
55	29.8399	28.4511	27.1242	-1.23	1.22	4.9%	-4.7%
56	28.7361	27.3667	26.0600	-1.26	1.26	5.0%	-4.8%
57	27.6777	26.3282	25.0420	-1.30	1.29	5.1%	-4.9%
58	26.6627	25.3334	24.0680	-1.34	1.33	5.2%	-5.0%
59	25.6892	24.3804	23.1359	-1.37	1.36	5.4%	-5.1%
60	24.7552	23.4671	22.2437	-1.41	1.40	5.5%	-5.2%
61	23.8589	22.5917	21.3896	-1.45	1.43	5.6%	-5.3%
62	22.9988	21.7525	20.5716	-1.49	1.47	5.7%	-5.4%
63	22.1730	20.9478	19.7883	-1.52	1.50	5.8%	-5.5%
64	21.3803	20.1761	19.0378	-1.56	1.54	6.0%	-5.6%
65	20.6189	19.4358	18.3188	-1.60	1.57	6.1%	-5.7%
66	19.8877	18.7257	17.6297	-1.64	1.61	6.2%	-5.9%
67	19.1853	18.0442	16.9693	-1.67	1.64	6.3%	-6.0%
68	18.5104	17.3902	16.3361	-1.71	1.68	6.4%	-6.1%
69	17.8619	16.7624	15.7290	-1.75	1.71	6.6%	-6.2%
70	17.2386	16.1597	15.1468	-1.79	1.75	6.7%	-6.3%
71	16.6395	15.5810	14.5884	-1.83	1.79	6.8%	-6.4%
72	16.0635	15.0253	14.0528	-1.87	1.82	6.9%	-6.5%
73	15.5096	14.4915	13.5388	-1.91	1.86	7.0%	-6.6%
74	14.9770	13.9787	13.0456	-1.95	1.89	7.1%	-6.7%
75	14.4647	13.4860	12.5723	-1.99	1.93	7.3%	-6.8%
76	13.9719	13.0126	12.1180	-2.03	1.97	7.4%	-6.9%
77	13.4978	12.5576	11.6818	-2.07	2.00	7.5%	-7.0%
78	13.0416	12.1204	11.2630	-2.11	2.04	7.6%	-7.1%
79	12.6026	11.7000	10.8609	-2.15	2.08	7.7%	-7.2%



R - T Table

Part No. : TTC3A104F4193FY10

R25=100KOhm ±1%

B25/85 = 4190 K ± 3%

Temperature (°C)	Rmax. (KΩ)	Rnor. (KΩ)	Rmin. (KΩ)	Temperature Tol. (°C)		Resistance Tol. (%)	
80	12.1801	11.2958	10.4747	-2.19	2.11	7.8%	-7.3%
81	11.7735	10.9072	10.1037	-2.23	2.15	7.9%	-7.4%
82	11.3820	10.5335	9.74734	-2.27	2.19	8.1%	-7.5%
83	11.0051	10.1741	9.40495	-2.31	2.22	8.2%	-7.6%
84	10.6421	9.82839	9.07595	-2.35	2.26	8.3%	-7.7%
85	10.2927	9.49580	8.75977	-2.40	2.30	8.4%	-7.8%
86	9.95605	9.17582	8.45590	-2.44	2.34	8.5%	-7.8%
87	9.63183	8.86793	8.16379	-2.48	2.38	8.6%	-7.9%
88	9.31951	8.57163	7.88298	-2.52	2.41	8.7%	-8.0%
89	9.01860	8.28646	7.61299	-2.57	2.45	8.8%	-8.1%
90	8.72868	8.01197	7.35337	-2.61	2.49	8.9%	-8.2%
91	8.44929	7.74772	7.10370	-2.65	2.53	9.1%	-8.3%
92	8.18003	7.49331	6.86356	-2.70	2.57	9.2%	-8.4%
93	7.92050	7.24834	6.63256	-2.74	2.61	9.3%	-8.5%
94	7.67033	7.01243	6.41033	-2.79	2.65	9.4%	-8.6%
95	7.42915	6.78523	6.19650	-2.83	2.69	9.5%	-8.7%
96	7.19660	6.56638	5.99074	-2.88	2.73	9.6%	-8.8%
97	6.97236	6.35555	5.79272	-2.93	2.77	9.7%	-8.9%
98	6.75610	6.15242	5.60212	-2.97	2.81	9.8%	-8.9%
99	6.54751	5.95668	5.41864	-3.02	2.85	9.9%	-9.0%
100	6.34629	5.76805	5.24198	-3.07	2.89	10.0%	-9.1%
101	6.15216	5.58625	5.07188	-3.11	2.93	10.1%	-9.2%
102	5.96485	5.41099	4.90806	-3.16	2.98	10.2%	-9.3%
103	5.78409	5.24202	4.75028	-3.21	3.02	10.3%	-9.4%
104	5.60963	5.07910	4.59828	-3.26	3.06	10.4%	-9.5%
105	5.44123	4.92198	4.45184	-3.30	3.10	10.5%	-9.6%
106	5.27865	4.77044	4.31072	-3.35	3.14	10.7%	-9.6%
107	5.12167	4.62425	4.17472	-3.40	3.19	10.8%	-9.7%
108	4.97007	4.48320	4.04363	-3.45	3.23	10.9%	-9.8%
109	4.82364	4.34710	3.91725	-3.50	3.27	11.0%	-9.9%
110	4.68220	4.21575	3.79539	-3.55	3.32	11.1%	-10.0%
111	4.54554	4.08895	3.67786	-3.60	3.36	11.2%	-10.1%
112	4.41348	3.96654	3.56450	-3.65	3.40	11.3%	-10.1%
113	4.28584	3.84833	3.45514	-3.70	3.44	11.4%	-10.2%
114	4.16245	3.73417	3.34962	-3.75	3.49	11.5%	-10.3%
115	4.04316	3.62389	3.24777	-3.80	3.53	11.6%	-10.4%
116	3.92780	3.51734	3.14946	-3.85	3.57	11.7%	-10.5%
117	3.81622	3.41438	3.05454	-3.90	3.62	11.8%	-10.5%
118	3.70828	3.31486	2.96288	-3.95	3.66	11.9%	-10.6%
119	3.60383	3.21864	2.87434	-4.00	3.70	12.0%	-10.7%



