



AiP74LVC244

Octal Buffer/Line Driver; 3-state

Product Specification

Specification Revision History:

Version	Date	Description
2017-09-A1	2017-09	New
2021-12-A2	2021-12	Modify Ordering Information
2022-02-A3	2022-02	Modify ambient temperature to $-40^{\circ}\text{C}\sim+105^{\circ}\text{C}$ and add electrical characteristics of $-40^{\circ}\text{C}\sim+105^{\circ}\text{C}$



General Description

The AiP74LVC244 is an octal non-inverting buffer/line driver with 3-state outputs. The 3-state outputs are controlled by the output enable inputs $1\overline{OE}$ and $2\overline{OE}$. A HIGH on $n\overline{OE}$ causes the outputs to assume a high-impedance OFF-state. Schmitt-trigger action at all inputs makes the circuit highly tolerant for slower input rise and fall times.

Inputs can be driven from either 3.3 V or 5.0 V devices. In 3-state operation, outputs can handle 5V. These features allow the use of these devices as translators in a mixed 3.3 V and 5V environment.

Features:

- 5 V tolerant inputs/outputs for interfacing with 5V logic
- Wide supply voltage range from 1.2V to 3.6V
- CMOS low power consumption
- Direct interface with TTL levels
- Inputs accept voltages up to 5.5V
- High-impedance when $V_{CC}=0V$
- Packaging information: SOP20/TSSOP20/DHVQFN20

**Ordering Information:****Tube packing specifications:**

Part number	Packaging form	Marking code	Tube quantity	Boxed tube quantity	Boxed quantity	Notes
AiP74LVC244SA20.TB	SOP20	74LVC244	35 PCS/tube	80 tube/box	2800 PCS/box	Dimensions of plastic enclosure: 12.8mm×7.5mm Pin spacing: 1.27mm
AiP74LVC244TA20.TB	TSSOP20	74LVC244	70 PCS/tube	200 tube/box	14000 PCS/box	Dimensions of plastic enclosure: 6.5mm×4.4mm Pin spacing: 0.65mm

Reel packing specifications:

Part number	Packaging form	Marking code	Reel quantity	Boxed reel quantity	Notes
AiP74LVC244SA20.TR	SOP20	74LVC244	2000 PCS/reel	4000 PCS/box	Dimensions of plastic enclosure: 12.8mm×7.5mm Pin spacing:1.27mm
AiP74LVC244TA20.TR	TSSOP20	74LVC244	4000 PCS/reel	8000 PCS/box	Dimensions of plastic enclosure: 6.5mm×4.4mm Pin spacing:0.65mm
AiP74LVC244QE20.TR	DHVQFN20	74LVC244	3000 PCS/reel	3000 PCS/box	Dimensions of plastic enclosure: 4.5mm×2.5mm Pin spacing:0.5mm

Note: If the physical information is inconsistent with the ordering information, please refer to the actual product.



2、Block Diagram And Pin Description

2.1、Block Diagram

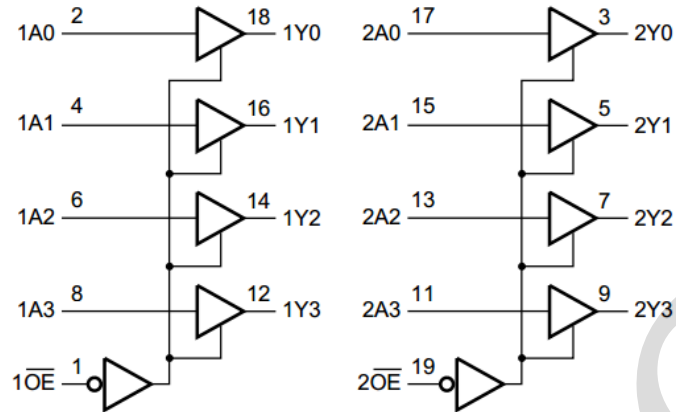

Figure 1. Logic symbol

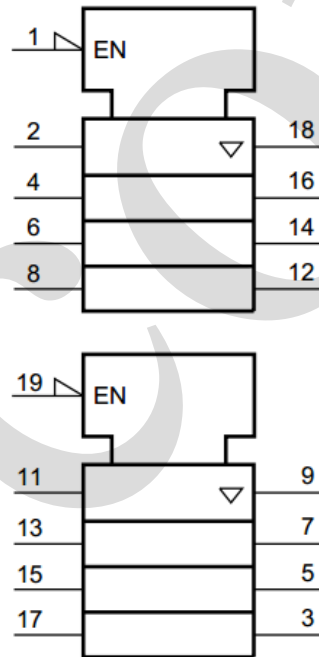

Figure 2. IEC logic diagram

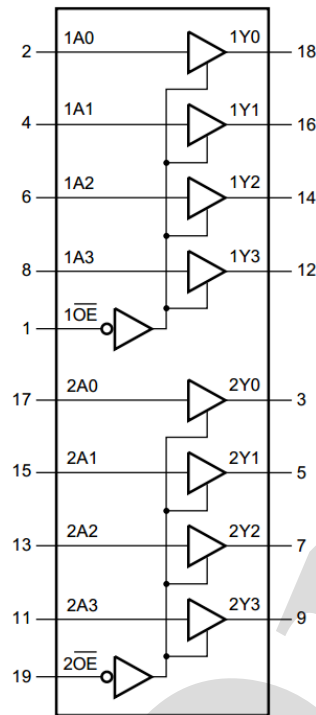
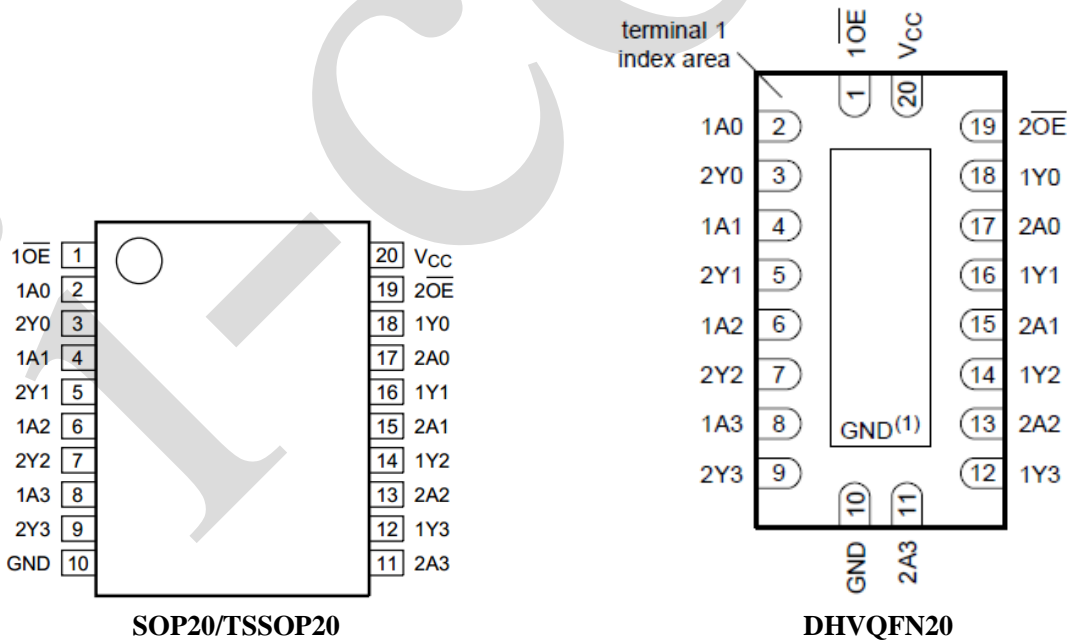

Figure 3. Functional diagram

2.2、Pin Configurations



Note: (1) This is not a supply pin. The substrate is attached to this pad using conductive die attach material. There is no electrical or mechanical requirement to solder this pad. However, if it is soldered, the solder land should remain floating or be connected to GND.



2.3、Pin Description

Pin No.	Pin Name	Description
1	$\overline{1OE}$	output enable input (active LOW)
2	1A0	data input
3	2Y0	bus output
4	1A1	data input
5	2Y1	bus output
6	1A2	data input
7	2Y2	bus output
8	1A3	data input
9	2Y3	bus output
10	GND	ground (0V)
11	2A3	data input
12	1Y3	bus output
13	2A2	data input
14	1Y2	bus output
15	2A1	data input
16	1Y1	bus output
17	2A0	data input
18	1Y0	bus output
19	$2OE$	output enable input (active LOW)
20	V_{CC}	supply voltage

2.4、Function Table

Input		Output
\overline{nOE}	nAn	nYn
L	L	L
L	H	H
H	X	Z

Note: H=HIGH voltage level; L=LOW voltage level; X=don't care; Z=high-impedance OFF-state.



3、Electrical Parameter

3.1、Absolute Maximum Ratings

(Voltages are referenced to GND(ground=0V), unless otherwise specified.)

Parameter	Symbol	Conditions	Min.	Max.	Unit
supply voltage	V_{CC}	-	-0.5	6.5	V
input clamping current	I_{IK}	$V_I < 0V$	-50	-	mA
input voltage	V_I	-	-0.5	6.5	V
output clamping current	I_{OK}	$V_O > V_{CC}$ or $V_O < 0V$	-	± 50	mA
output voltage	V_O	output HIGH or LOW	-0.5	$V_{CC}+0.5$	V
		output 3-state	-0.5	6.5	V
output current	I_O	$V_O=0V$ to V_{CC}	-	± 50	mA
supply current	I_{CC}	-	-	100	mA
ground current	I_{GND}	-	-100	-	mA
storage temperature	T_{stg}	-	-65	150	°C
total power dissipation	P_{tot}	-	-	500	mW
Soldering Temperature	T_L	10s		250	°C

Note:

[1] The minimum input voltage ratings may be exceeded if the input current ratings are observed.

[2] The output voltage ratings may be exceeded if the output current ratings are observed.

[3] For SOP20 packages: above 70°C the value of P_{tot} derates linearly with 8mW/K.

For (T)SSOP20 packages: above 60°C the value of P_{tot} derates linearly with 5.5mW/K.

For DHVQFN20 packages: above 60°C the value of P_{tot} derates linearly with 4.5mW/K.

3.2、Recommended Operating Conditions

Parameter	Symbol	Conditions	Min.	Typ.	Max.	Unit
supply voltage	V_{CC}	-	1.65	-	3.6	V
		functional	1.2	-	3.6	V
input voltage	V_I	-	0	-	5.5	V
output voltage	V_O	output HIGH or LOW	0	-	V_{CC}	V
		output 3-state	0	-	5.5	V
ambient temperature	T_{amb}	in free air	-40	-	+105	°C
input transition rise and fall rate	$\Delta t/\Delta V$	$V_{CC}= 1.2V$ to $2.7V$	0	-	20	ns/V
		$V_{CC}= 2.7V$ to $3.6V$	0	-	10	ns/V



3.3、Electrical Characteristics

3.3.1、DC Characteristics 1

($T_{amb} = -40^{\circ}\text{C}$ to $+85^{\circ}\text{C}$, voltages are referenced to GND (ground=0V), unless otherwise specified.)

Parameter	Symbol	Conditions	Min.	Typ.	Max.	Unit	
HIGH-level input voltage	V_{IH}	$V_{CC} = 1.2\text{V}$	1.08	-	-	V	
		$V_{CC} = 1.65\text{V}$ to 1.95V	$0.65 \times V_{CC}$	-	-	V	
		$V_{CC} = 2.3\text{V}$ to 2.7V	1.7	-	-	V	
		$V_{CC} = 2.7\text{V}$ to 3.6V	2.0	-	-	V	
LOW-level input voltage	V_{IL}	$V_{CC} = 1.2\text{V}$	-	-	0.12	V	
		$V_{CC} = 1.65\text{V}$ to 1.95V	-	-	$0.35 \times V_{CC}$	V	
		$V_{CC} = 2.3\text{V}$ to 2.7V	-	-	0.7	V	
		$V_{CC} = 2.7\text{V}$ to 3.6V	-	-	0.8	V	
HIGH-level output voltage	V_{OH}	$V_I = V_{IH}$ or V_{IL}	$I_O = -100\mu\text{A}; V_{CC} = 1.65\text{V}$ to 3.6V	$V_{CC} - 0.2$	-	-	V
			$I_O = -4\text{mA}; V_{CC} = 1.65\text{V}$	1.2	-	-	V
			$I_O = -8\text{mA}; V_{CC} = 2.3\text{V}$	1.8	-	-	V
			$I_O = -12\text{mA}; V_{CC} = 2.7\text{V}$	2.2	-	-	V
			$I_O = -18\text{mA}; V_{CC} = 3.0\text{V}$	2.4	-	-	V
			$I_O = -24\text{mA}; V_{CC} = 3.0\text{V}$	2.2	-	-	V
LOW-level output voltage	V_{OL}	$V_I = V_{IH}$ or V_{IL}	$I_O = 100\mu\text{A}; V_{CC} = 1.65\text{V}$ to 3.6V	-	-	0.2	V
			$I_O = 4\text{mA}; V_{CC} = 1.65\text{V}$	-	-	0.45	V
			$I_O = 8\text{mA}; V_{CC} = 2.3\text{V}$	-	-	0.6	V
			$I_O = 12\text{mA}; V_{CC} = 2.7\text{V}$	-	-	0.4	V
			$I_O = 24\text{mA}; V_{CC} = 3.0\text{V}$	-	-	0.55	V
input leakage current	I_I	$V_{CC} = 3.6\text{V}; V_I = 5.5\text{V}$ or GND	-	± 0.1	± 5	μA	
OFF-state output current	I_{OZ}	$V_{CC} = 3.6\text{V}; V_I = V_{IH}$ or $V_{IL}; V_O = 5.5\text{V}$ or GND	-	± 0.1	± 5	μA	
power-off leakage current	I_{OFF}	$V_{CC} = 0\text{V}; V_I$ or $V_O = 5.5\text{V}$	-	± 0.1	± 10	μA	
supply current	I_{CC}	$V_{CC} = 3.6\text{V}; V_I = V_{CC}$ or GND; $I_O = 0\text{A}$	-	0.1	10	μA	
additional supply current	ΔI_{CC}	per input pin; $V_{CC} = 2.7\text{V}$ to $3.6\text{V}; V_I = V_{CC} - 0.6\text{V}; I_O = 0\text{A}$	-	5	500	μA	
input capacitance	C_I	-	-	4	-	pF	

Note:

[1] All typical values are measured at $V_{CC} = 3.3\text{V}$ (unless stated otherwise) and $T_{amb} = 25^{\circ}\text{C}$.



[2] The bus hold circuit is switched off when $V_I > V_{CC}$ allowing 5.5 V on the input terminal.

3.3.2、DC Characteristics 2

($T_{amb} = -40^{\circ}\text{C}$ to $+105^{\circ}\text{C}$, voltages are referenced to GND (ground=0V), unless otherwise specified.)

Parameter	Symbol	Conditions	Min.	Typ.	Max.	Unit	
HIGH-level input voltage	V_{IH}	$V_{CC} = 1.2\text{V}$	1.08	-	-	V	
		$V_{CC} = 1.65\text{V}$ to 1.95V	$0.65 \times V_{CC}$	-	-	V	
		$V_{CC} = 2.3\text{V}$ to 2.7V	1.7	-	-	V	
		$V_{CC} = 2.7\text{V}$ to 3.6V	2.0	-	-	V	
LOW-level input voltage	V_{IL}	$V_{CC} = 1.2\text{V}$	-	-	0.12	V	
		$V_{CC} = 1.65\text{V}$ to 1.95V	-	-	$0.35 \times V_{CC}$	V	
		$V_{CC} = 2.3\text{V}$ to 2.7V	-	-	0.7	V	
		$V_{CC} = 2.7\text{V}$ to 3.6V	-	-	0.8	V	
HIGH-level output voltage	V_{OH}	$V_I = V_{IH}$ or V_{IL}	$I_O = -100\mu\text{A}; V_{CC} = 1.65\text{V}$ to 3.6V	$V_{CC} - 0.3$	-	-	V
			$I_O = -4\text{mA}; V_{CC} = 1.65\text{V}$	1.05	-	-	V
			$I_O = -8\text{mA}; V_{CC} = 2.3\text{V}$	1.65	-	-	V
			$I_O = -12\text{mA}; V_{CC} = 2.7\text{V}$	2.05	-	-	V
			$I_O = -18\text{mA}; V_{CC} = 3.0\text{V}$	2.25	-	-	V
			$I_O = -24\text{mA}; V_{CC} = 3.0\text{V}$	2.0	-	-	V
LOW-level output voltage	V_{OL}	$V_I = V_{IH}$ or V_{IL}	$I_O = 100\mu\text{A}; V_{CC} = 1.65\text{V}$ to 3.6V	-	-	0.3	V
			$I_O = 4\text{mA}; V_{CC} = 1.65\text{V}$	-	-	0.65	V
			$I_O = 8\text{mA}; V_{CC} = 2.3\text{V}$	-	-	0.8	V
			$I_O = 12\text{mA}; V_{CC} = 2.7\text{V}$	-	-	0.6	V
			$I_O = 24\text{mA}; V_{CC} = 3.0\text{V}$	-	-	0.8	V
input leakage current	I_I	$V_{CC} = 3.6\text{V}; V_I = 5.5\text{V}$ or GND	-	-	± 20	μA	
OFF-state output current	I_{OZ}	$V_{CC} = 3.6\text{V}; V_I = V_{IH}$ or $V_{IL}; V_O = 5.5\text{V}$ or GND	-	-	± 20	μA	
power-off leakage current	I_{OFF}	$V_{CC} = 0\text{V}; V_I$ or $V_O = 5.5\text{V}$	-	-	± 20	μA	
supply current	I_{CC}	$V_{CC} = 3.6\text{V}; V_I = V_{CC}$ or GND; $I_O = 0\text{A}$	-	-	40	μA	
additional supply current	ΔI_{CC}	per input pin; $V_{CC} = 2.7\text{V}$ to $3.6\text{V}; V_I = V_{CC} - 0.6\text{V}; I_O = 0\text{A}$	-	-	5000	μA	

Note:

[1] All typical values are measured at $V_{CC} = 3.3\text{V}$ (unless stated otherwise) and $T_{amb} = 25^{\circ}\text{C}$.



[2] The bus hold circuit is switched off when $V_I > V_{CC}$ allowing 5.5 V on the input terminal.

3.3.3、 AC Characteristics 1

($T_{amb} = -40^{\circ}C$ to $+85^{\circ}C$, voltages are referenced to GND (ground=0V), unless otherwise specified.)

Parameter	Symbol	Conditions	Min.	Typ.	Max.	Unit	
nAn to nYn propagation delay	t_{pd}	see Figure 5	$V_{CC} = 1.2V$	-	17.0	-	ns
			$V_{CC} = 1.65V$ to $1.95V$	1.5	6.4	13.7	ns
			$V_{CC} = 2.3V$ to $2.7V$	1.0	3.4	7.1	ns
			$V_{CC} = 2.7V$	1.5	3.4	6.9	ns
			$V_{CC} = 3.0V$ to $3.6V$	1.5	2.9	5.9	ns
$\bar{n}OE$ to nYn enable time	t_{en}	see Figure 6	$V_{CC} = 1.2V$	-	24.0	-	ns
			$V_{CC} = 1.65V$ to $1.95V$	1.5	7.0	17.3	ns
			$V_{CC} = 2.3V$ to $2.7V$	1.5	3.9	9.5	ns
			$V_{CC} = 2.7V$	1.5	4.1	8.6	ns
			$V_{CC} = 3.0V$ to $3.6V$	1.0	3.2	7.6	ns
$\bar{n}OE$ to nYn disable time	t_{dis}	see Figure 6	$V_{CC} = 1.2V$	-	9.0	-	ns
			$V_{CC} = 1.65V$ to $1.95V$	2.2	4.5	9.8	ns
			$V_{CC} = 2.3V$ to $2.7V$	0.5	3.6	5.5	ns
			$V_{CC} = 2.7V$	1.5	3.3	6.8	ns
			$V_{CC} = 3.0V$ to $3.6V$	1.5	3.1	5.8	ns
output skew time	$t_{sk(o)}$	-	-	-	1.0	ns	
power dissipation capacitance	C_{PD}	per input; $V_I = GND$ to V_{CC}	$V_{CC} = 1.65V$ to $1.95V$	-	6.4	-	pF
			$V_{CC} = 2.3V$ to $2.7V$	-	9.6	-	
			$V_{CC} = 3.0V$ to $3.6V$	-	12.5	-	

Note:

[1] Typical values are measured at $T_{amb} = 25^{\circ}C$ and $V_{CC} = 1.2V, 1.8V, 2.5V, 2.7V,$ and $3.3V$ respectively.

[2] t_{pd} is the same as t_{PLH} and t_{PHL} .

t_{en} is the same as t_{PZH} and t_{PZL} .

t_{dis} is the same as t_{PLZ} and t_{PHZ} .

[3] Skew between any two outputs of the same package switching in the same direction. This parameter is guaranteed by design.

[4] C_{PD} is used to determine the dynamic power dissipation (P_D in uW).

$$P_D = (C_{PD} \times V_{CC}^2 \times f_i \times N) + \sum (C_L \times V_{CC}^2 \times f_o) \text{ where:}$$

f_i = input frequency in MHz.

f_o = output frequency in MHz.

C_L = output load capacitance in pF.

V_{CC} = supply voltage in V_{olt} .

N = number of inputs switching.

$\sum (C_L \times V_{CC}^2 \times f_o)$ = sum of the outputs.



3.3.4. AC Characteristics 2

($T_{amb} = -40^{\circ}\text{C}$ to $+105^{\circ}\text{C}$, voltages are referenced to GND (ground=0V), unless otherwise specified.)

Parameter	Symbol	Conditions	Min.	Typ.	Max.	Unit	
nAn to nYn propagation delay	t_{pd}	see Figure 5	$V_{CC} = 1.65\text{V to }1.95\text{V}$	1.5	-	15.8	ns
			$V_{CC} = 2.3\text{V to }2.7\text{V}$	1.0	-	8.2	ns
			$V_{CC} = 2.7\text{V}$	1.5	-	9.0	ns
			$V_{CC} = 3.0\text{V to }3.6\text{V}$	1.5	-	7.5	ns
nOE to nYn enable time	t_{en}	see Figure 6	$V_{CC} = 1.65\text{V to }1.95\text{V}$	1.5	-	20.0	ns
			$V_{CC} = 2.3\text{V to }2.7\text{V}$	1.5	-	11.0	ns
			$V_{CC} = 2.7\text{V}$	1.5	-	11.0	ns
			$V_{CC} = 3.0\text{V to }3.6\text{V}$	1.0	-	9.5	ns
nOE to nYn disable time	t_{dis}	see Figure 6	$V_{CC} = 1.65\text{V to }1.95\text{V}$	2.2	-	11.3	ns
			$V_{CC} = 2.3\text{V to }2.7\text{V}$	0.5	-	6.4	ns
			$V_{CC} = 2.7\text{V}$	1.5	-	8.5	ns
			$V_{CC} = 3.0\text{V to }3.6\text{V}$	1.5	-	7.5	ns
output skew time	$t_{sk(o)}$	-	-	-	1.5	ns	

Note:

- [1] Typical values are measured at $T_{amb} = 25^{\circ}\text{C}$ and $V_{CC} = 1.2\text{V}, 1.8\text{V}, 2.5\text{V}, 2.7\text{V},$ and 3.3V respectively.
- [2] t_{pd} is the same as t_{PLH} and t_{PHL} .
 t_{en} is the same as t_{PZH} and t_{PZL} .
 t_{dis} is the same as t_{PLZ} and t_{PHZ} .
- [3] Skew between any two outputs of the same package switching in the same direction. This parameter is guaranteed by design.



4、 Testing Circuit

4.1、 AC Testing Circuit

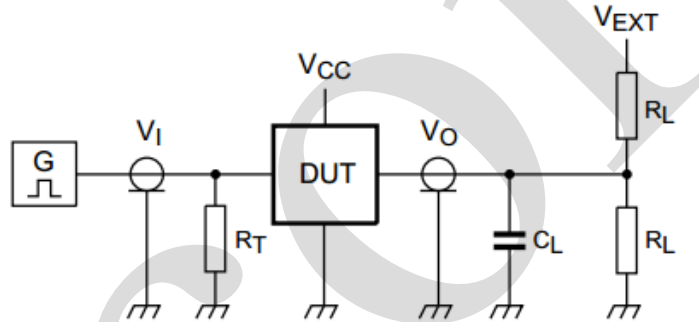
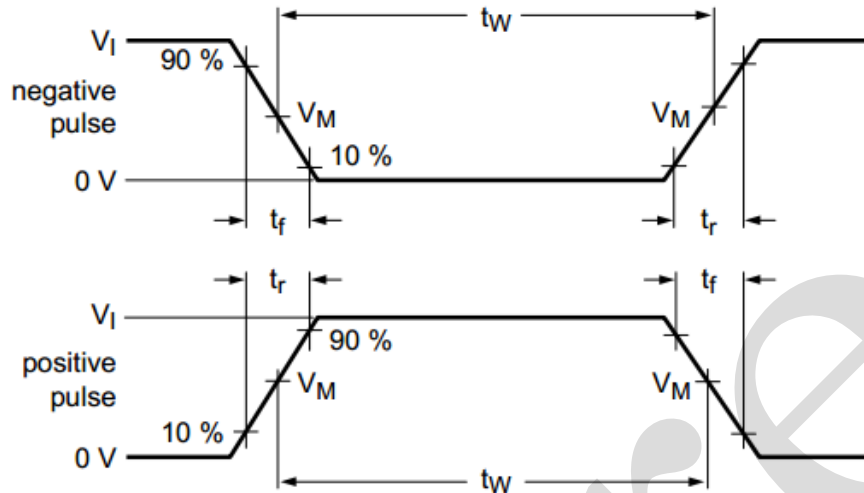

Figure 4. Test circuit for measuring switching times

Definitions for test circuit:

R_L =Load resistance.

C_L =Load capacitance including jig and probe capacitance.

R_T =Termination resistance should be equal to the output impedance Z_o of the pulse generator.

V_{EXT} =External voltage for measuring switching times.

4.2、 AC Testing Waveforms

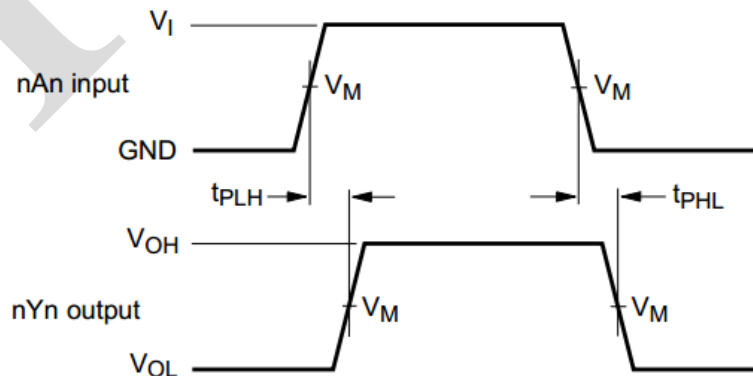

Figure 5. The input (nAn) to output (nYn) propagation delays

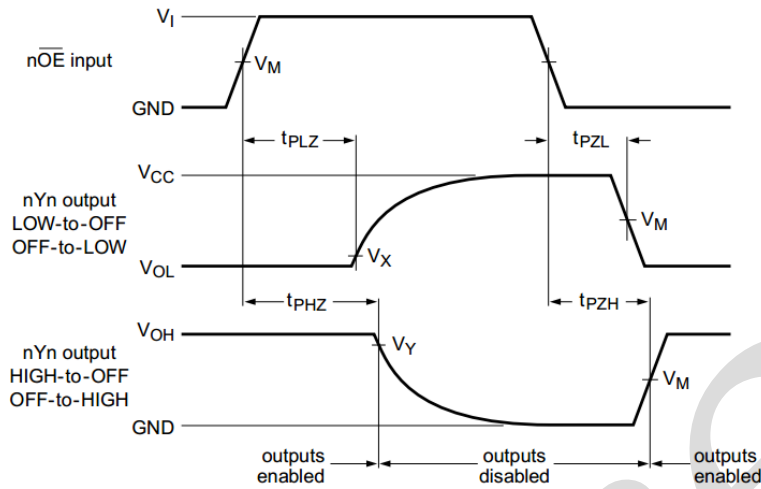

Figure 6. 3-state enable and disable times

4.3. Measurement Points

Supply voltage	Input		Output		
V_{CC}	V_I	V_M	V_M	V_X	V_Y
1.2V	V_{CC}	$0.5 \times V_{CC}$	$0.5 \times V_{CC}$	$V_{OL} + 0.15V$	$V_{OH} - 0.15V$
1.65V to 1.95V	V_{CC}	$0.5 \times V_{CC}$	$0.5 \times V_{CC}$	$V_{OL} + 0.15V$	$V_{OH} - 0.15V$
2.3V to 2.7V	V_{CC}	$0.5 \times V_{CC}$	$0.5 \times V_{CC}$	$V_{OL} + 0.15V$	$V_{OH} - 0.15V$
2.7V	2.7V	1.5V	1.5V	$V_{OL} + 0.3V$	$V_{OH} - 0.3V$
3.0V to 3.6V	2.7V	1.5V	1.5V	$V_{OL} + 0.3V$	$V_{OH} - 0.3V$

4.4. Test Data

Supply voltage	Input		Load		V_{EXT}		
V_{CC}	V_I	t_r, t_f	C_L	R_L	t_{PLH}, t_{PHL}	t_{PZH}, t_{PHZ}	t_{PZL}, t_{PLZ}
1.2V	V_{CC}	$\leq 2.0ns$	30pF	1k Ω	open	GND	$2 \times V_{CC}$
1.65V to 1.95V	V_{CC}	$\leq 2.0ns$	30pF	1k Ω	open	GND	$2 \times V_{CC}$
2.3V to 2.7V	V_{CC}	$\leq 2.0ns$	30pF	500 Ω	open	GND	$2 \times V_{CC}$
2.7V	2.7V	$\leq 2.5ns$	50pF	500 Ω	open	GND	$2 \times V_{CC}$
3.0V to 3.6V	2.7V	$\leq 2.5ns$	50pF	500 Ω	open	GND	$2 \times V_{CC}$



5、Package Information

5.1、SOP20

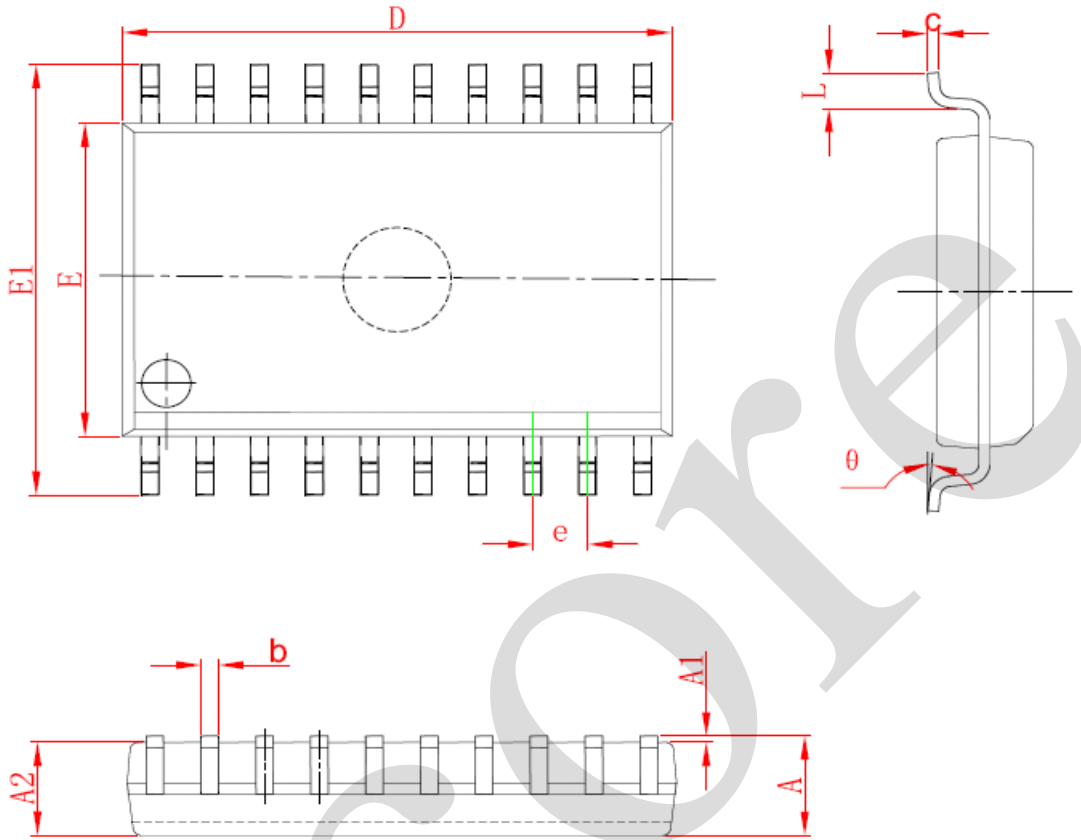

Symbol	Dimensions In Millimeters		Dimensions In Inches	
	Min	Max	Min	Max
A	2.350	2.650	0.093	0.104
A1	0.100	0.300	0.004	0.012
A2	2.100	2.500	0.083	0.098
b	0.330	0.510	0.013	0.020
c	0.204	0.330	0.008	0.013
D	12.520	13.000	0.493	0.512
E	7.400	7.600	0.291	0.299
E1	10.210	10.610	0.402	0.418
e	1.270 (BSC)		0.050 (BSC)	
L	0.400	1.270	0.016	0.050
θ	0°	8°	0°	8°



5.2、TSSOP20

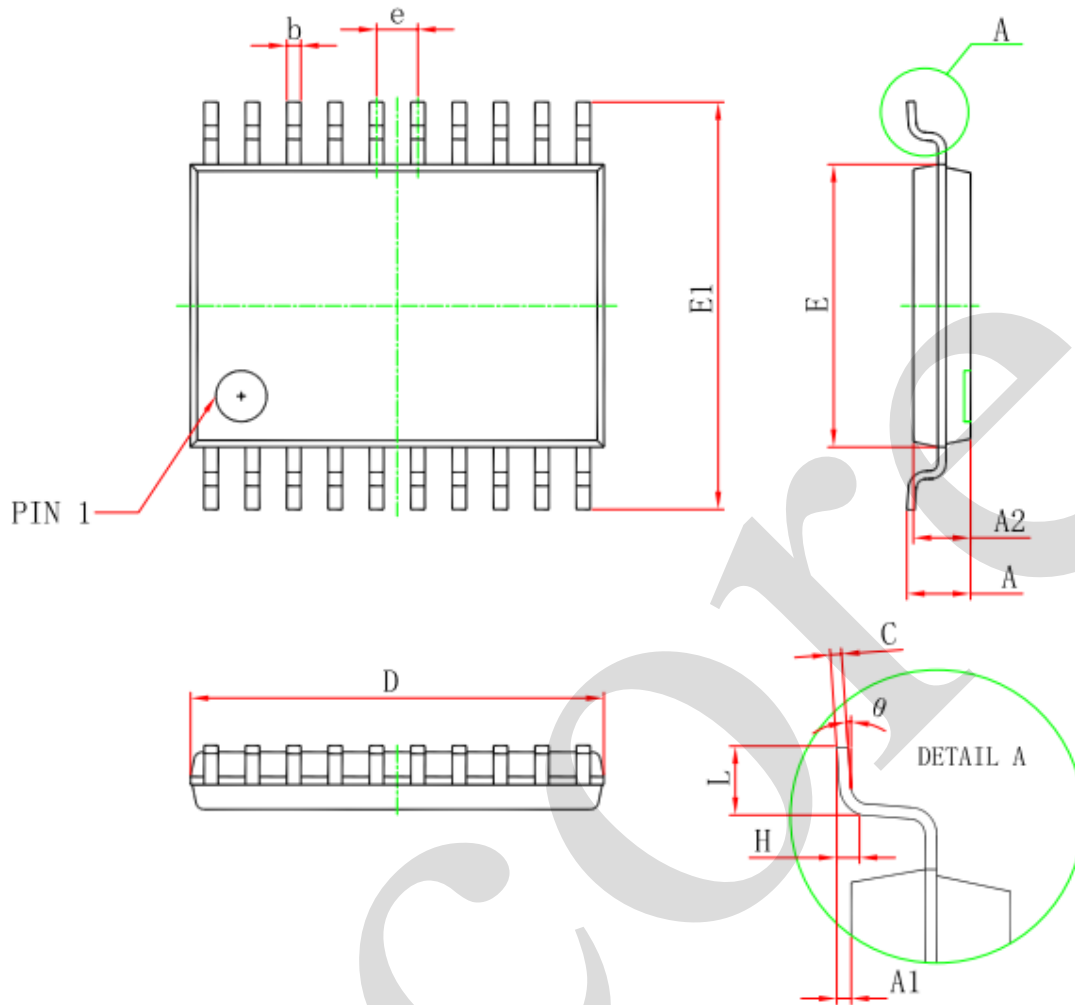

Symbol	Dimensions In Millimeters		Dimensions In Inches	
	Min	Max	Min	Max
D	6.400	6.600	0.252	0.259
E	4.300	4.500	0.169	0.177
b	0.190	0.300	0.007	0.012
e	0.090	0.200	0.004	0.008
E1	6.250	6.550	0.246	0.258
A		1.200		0.047
A2	0.800	1.000	0.031	0.039
A1	0.050	0.150	0.002	0.006
e	0.65 (BSC)		0.026 (BSC)	
L	0.500	0.700	0.020	0.028
H	0.25(TYP)		0.01(TYP)	
θ	1°	7°	1°	7°



5.3、DHVQFN20

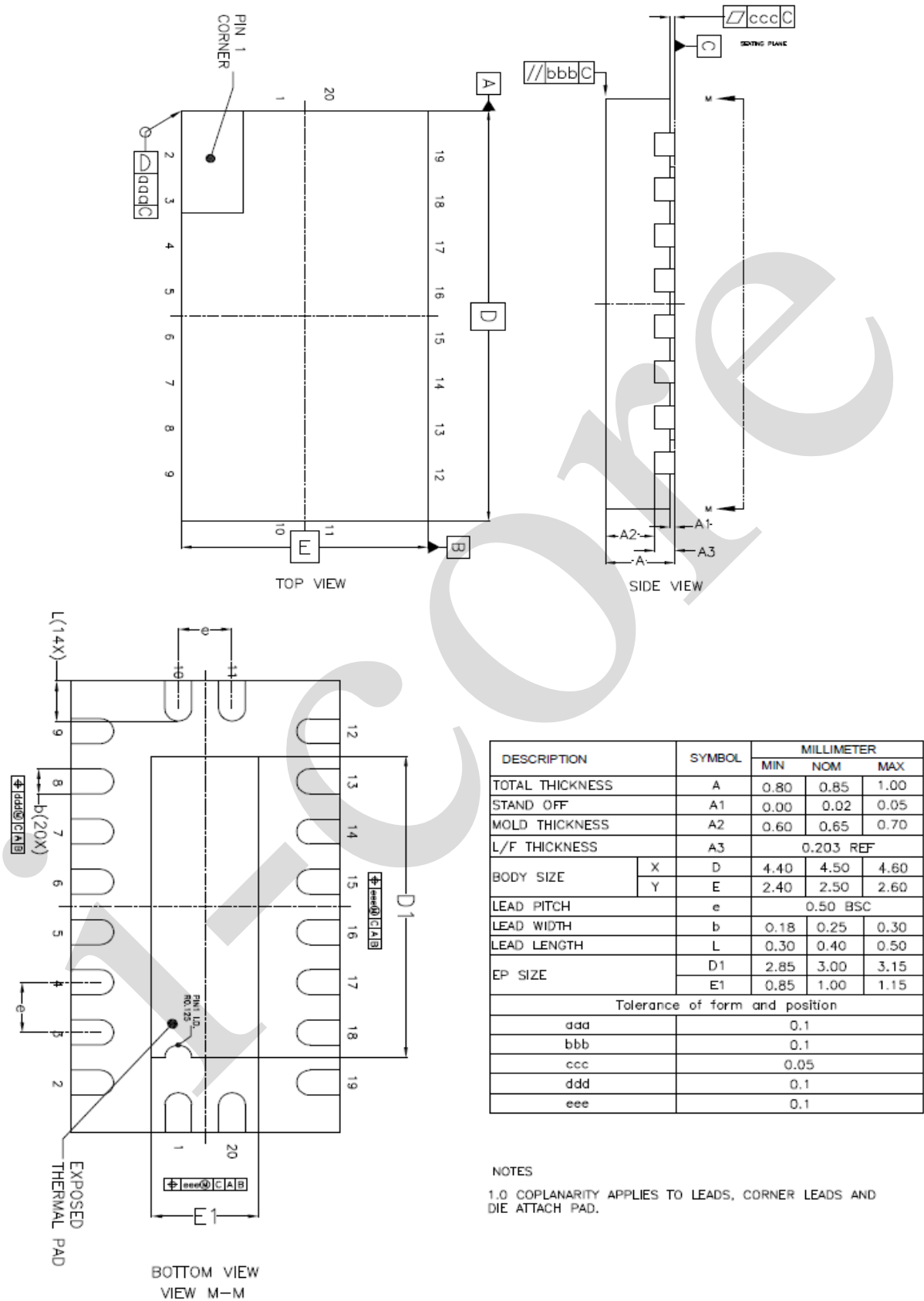



6、 Statements And Notes

6.1、 The name and content of Hazardous substances or Elements in the product

Part name	Hazardous substances or Elements									
	Lead and lead compounds	Mercury and mercury compounds	Cadmium and cadmium compounds	Hexavalent chromium compounds	Polybrominated biphenyls	Polybrominated biphenyl ethers	Dibutyl phthalate	Butylbenzyl phthalate	Di-2-ethylhexyl phthalate	Diisobutyl phthalate
Lead frame	○	○	○	○	○	○	○	○	○	○
Plastic resin	○	○	○	○	○	○	○	○	○	○
Chip	○	○	○	○	○	○	○	○	○	○
The lead	○	○	○	○	○	○	○	○	○	○
Plastic sheet installed	○	○	○	○	○	○	○	○	○	○
explanation	○: Indicates that the content of hazardous substances or elements in the detection limit of the following the SJ/T11363-2006 standard. ×: Indicates that the content of hazardous substances or elements exceeding the SJ/T11363-2006 Standard limit requirements.									

6.2、 Notion

Recommended carefully reading this information before the use of this product;

The information in this document are subject to change without notice;

This information is using to the reference only, the company is not responsible for any loss;

The company is not responsible for the any infringement of the third party patents or other rights of the responsibility.