

### Power Top View LEDs with Lens 67-31EP3-URD1224DBFBZ5-CT0D-AM



#### Features

##### Lead (Pb) Free Product - RoHS Compliant

- P-LCC-3 package.
- Colored diffused resin.
- Wide viewing angle 30°.
- Inner reflector and white package.
- Qualification according to AEC-Q101 rev C.
- Soldering methods: IR reflow soldering.
- Compliance with EU REACH

#### Applications

- Backlight: LCD, switches, symbol, mobile phone and illuminated advertising.
- Ideal for coupling into light guides.
- Substitution of traditional light.
- General applications.
- Optical indicator.
- Automotive

## Device Selection Guide

Chip Materials	Emitted Color	Resin Color
AlGaInP	Reddish Orange	Water Clear

## Absolute Maximum Ratings (Ta=25°C)

Parameter	Symbol	Rating	Unit
Forward Current	I <sub>F</sub>	70	mA
Power Dissipation	P <sub>d</sub>	182	mW
Junction Temperature	T <sub>j</sub>	125	°C
Operating Temperature	T <sub>opr</sub>	-40 ~ +100	°C
Storage Temperature	T <sub>stg</sub>	-40 ~ +110	°C
Thermal resistance	R <sub>th J-A</sub>	500	K/W
	R <sub>th J-S</sub>	300	K/W
ESD (Classification acc. AEC Q101)	ESD <sub>HBM</sub>	2000	V
	ESD <sub>MM</sub>	200	V
Soldering Temperature	T <sub>sol</sub>	Reflow Soldering : 260 °C for 30 sec. Hand Soldering : 350 °C for 3 sec.	

## Electro-Optical Characteristics (Ta=25°C)

Parameter	Symbol	Min.	Typ.	Max.	Unit	Condition
Luminous Intensity	I <sub>v</sub>	5600	---	18000	mcd	I <sub>F</sub> = 50mA
Viewing Angle	2θ <sub>1/2</sub>	---	30	---	deg	
Dominant Wavelength	λ <sub>d</sub>	612	---	624	nm	
Forward Voltage	V <sub>F</sub>	1.8	---	2.6	V	V <sub>R</sub> = 12V
Reverse Current	I <sub>R</sub>	---	---	10	μA	

Note:

1. Tolerance of Luminous Intensity: ±11%
2. Tolerance of Dominant Wavelength: ±1nm
3. Tolerance of Forward Voltage: ±0.1V

### Bin Range of Luminous Intensity

Bin Code	Min.(mcd)	Max.(mcd)	Flux(lm) typ.	Unit	Condition
DB	5600	7100	6	mcd	I <sub>F</sub> = 50mA
EA	7100	9000	7		
EB	9000	11200	9		
FA	11200	14400	11		
FB	14400	18000	13		

Note:  
 Typical of flux is only for reference

### Bin Range of Dominant Wavelength

Bin Code	Min.	Max.	Unit	Condition
KJ-1	612	615	nm	I <sub>F</sub> = 50mA
KJ-2	615	618		
KJ-3	618	621		
KJ-4	621	624		

### Bin Range of Forward Voltage

Bin Code	Min.	Max.	Unit	Condition
G3-1	1.80	2.00	V	I <sub>F</sub> =50mA
G3-2	2.00	2.20		
G3-3	2.20	2.40		
G3-4	2.40	2.60		

**Typical Electro-Optical Characteristics Curves**  
**Typical Curve of Spectral Distribution**

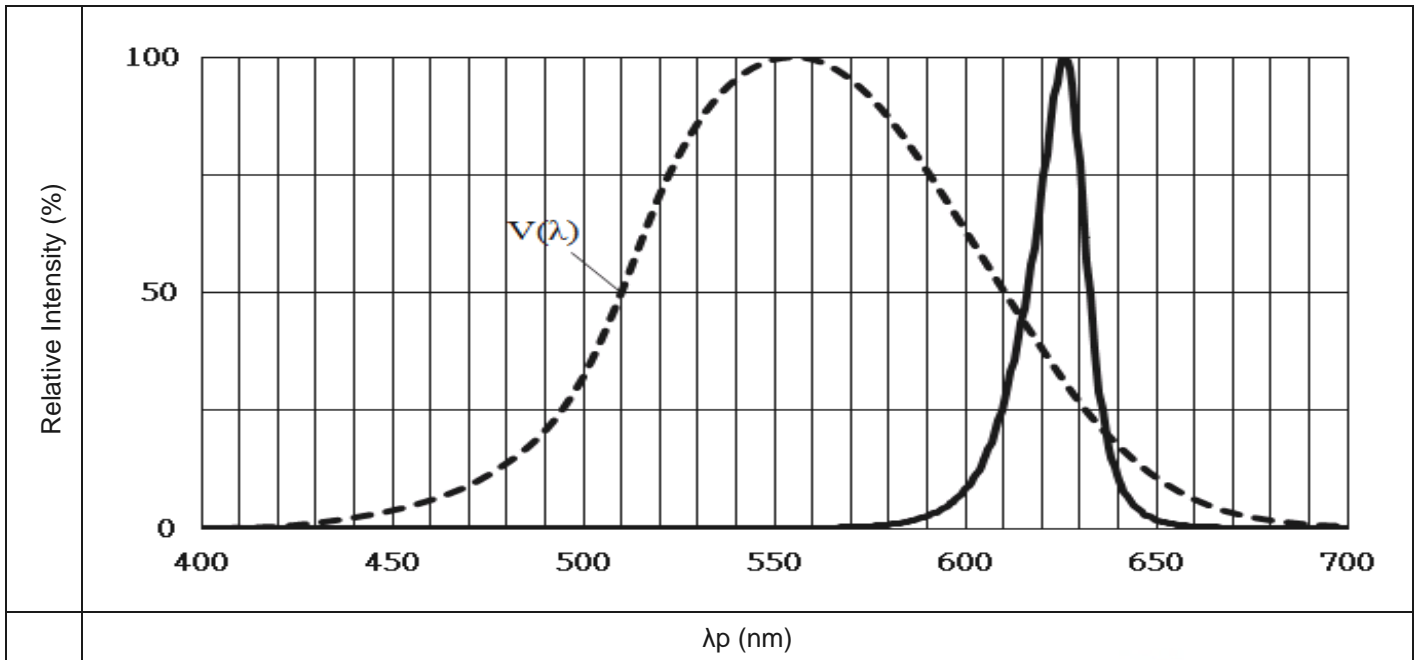

Note:  $V(\lambda)$ =Standard eye response curve;

**Diagram Characteristics of Radiation**

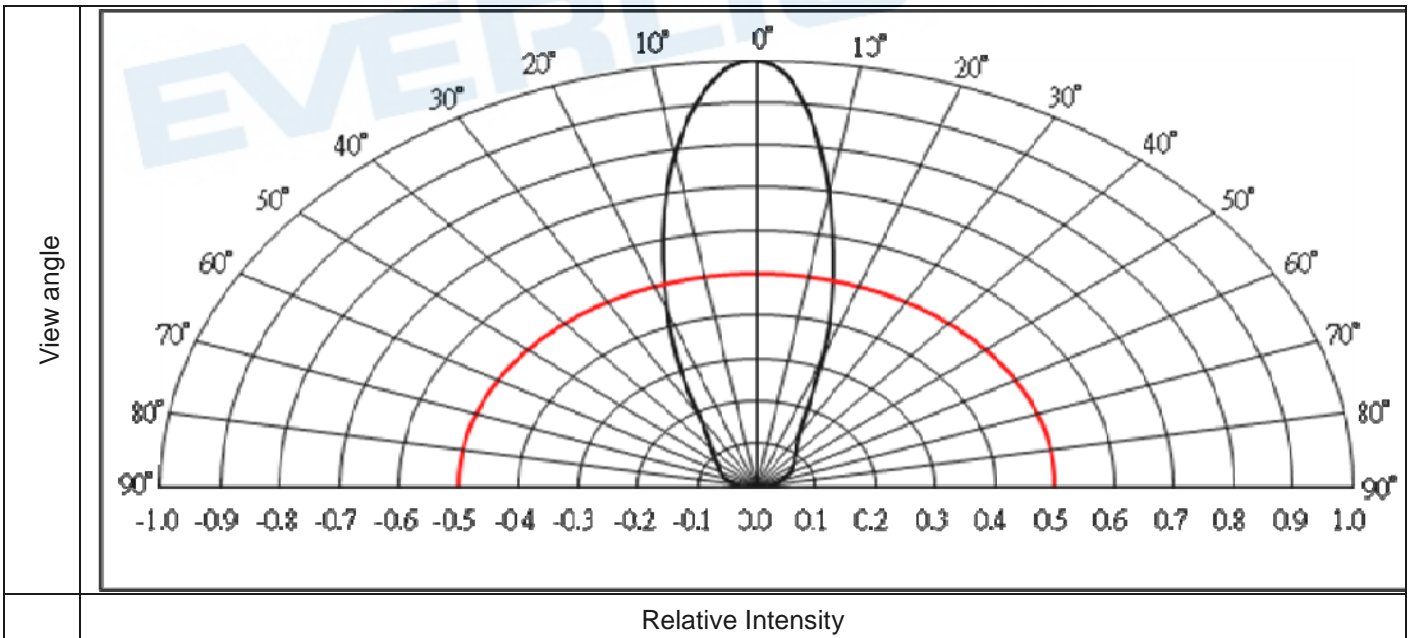

Typical Electro-Optical Characteristics Curves

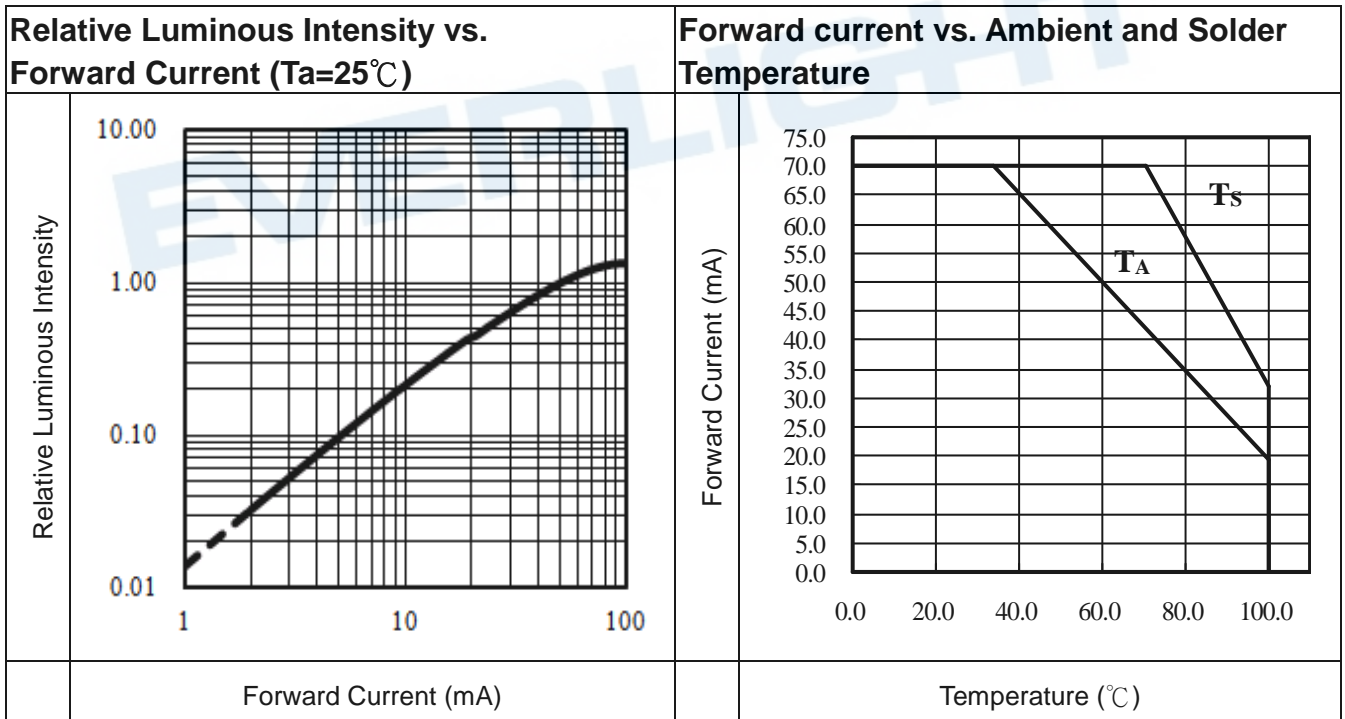
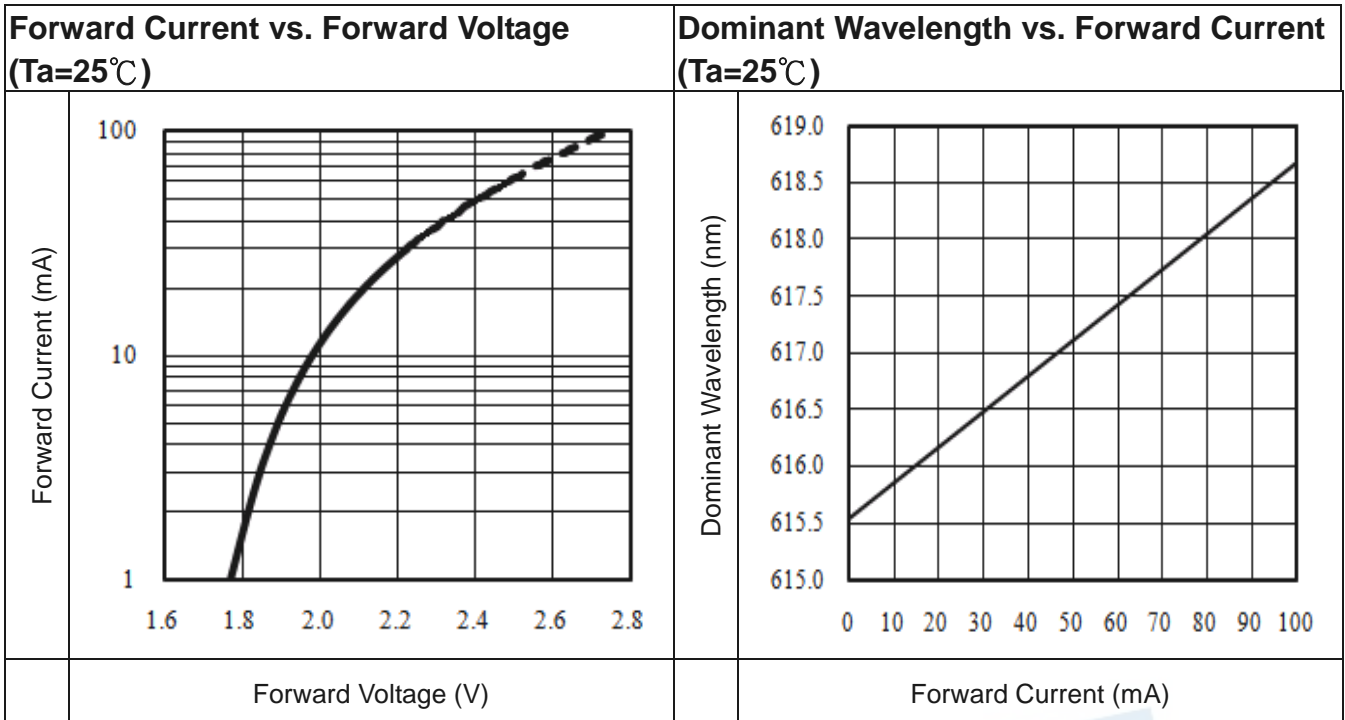

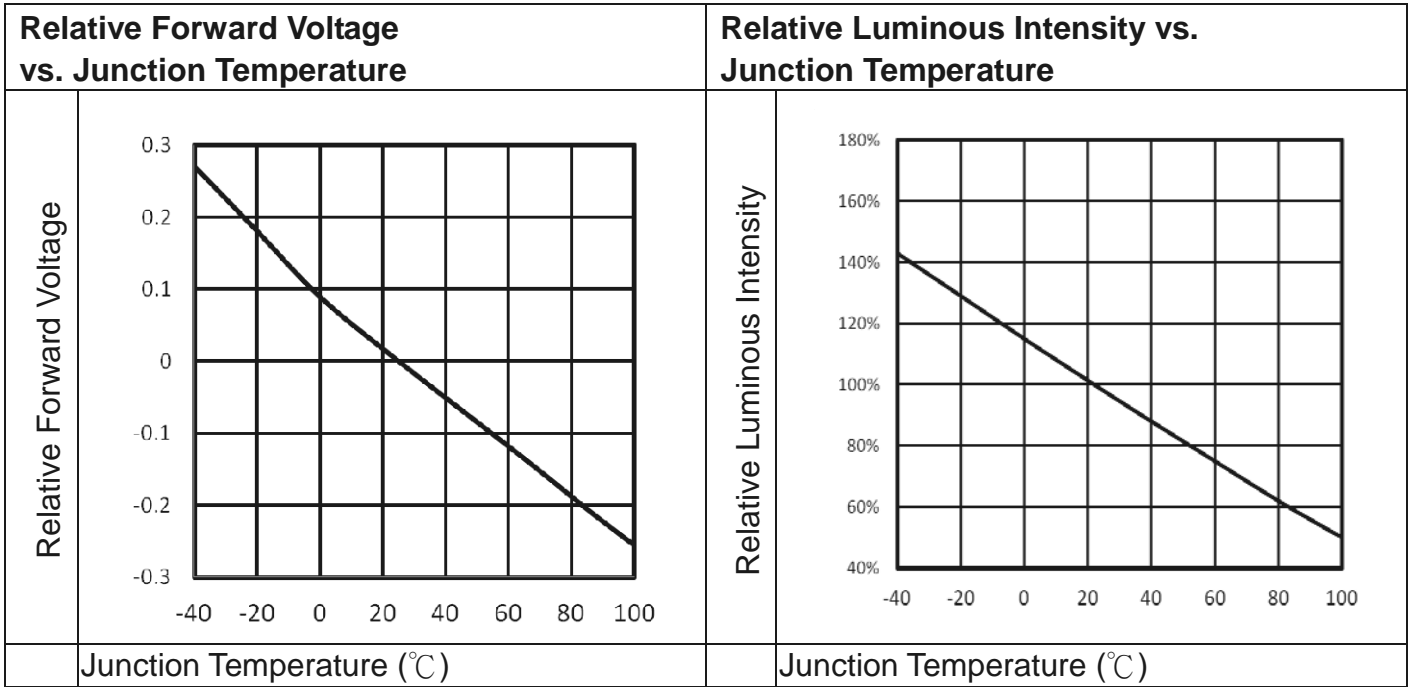

Note:  $\Delta V_F = V_F - V_F(25^\circ\text{C}) = f(T_j)$ ;  $I_F = 50\text{mA}$

Note:  $f(T_j) = I_v / I_v(25^\circ\text{C})$ ;  $I_F = 50\text{mA}$



Package Dimension

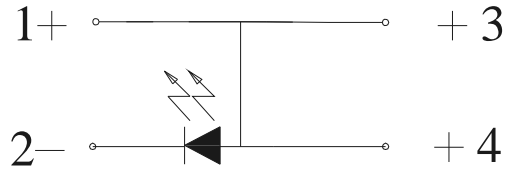
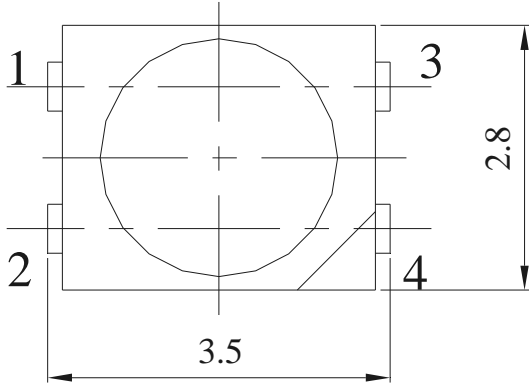

Polarity

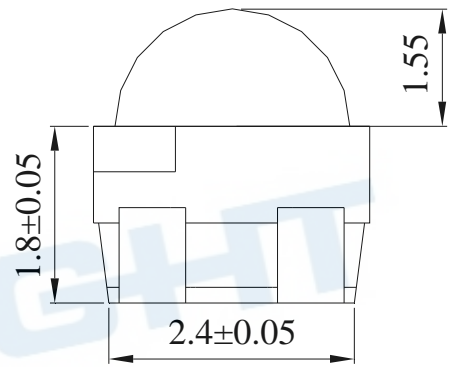
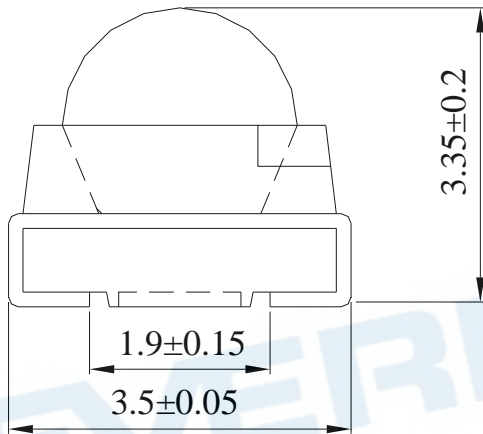

for reflow  
 soldering (propose)

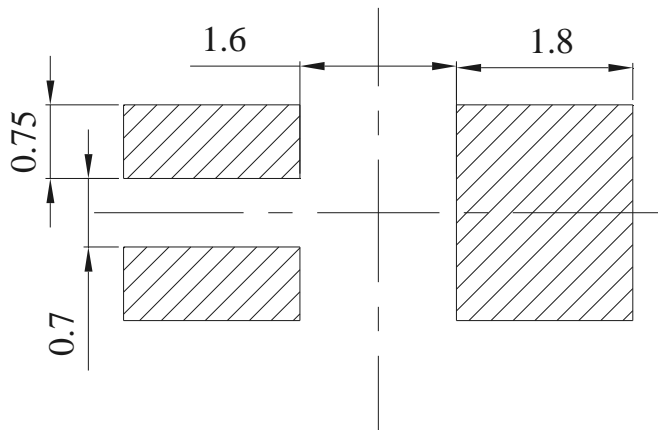
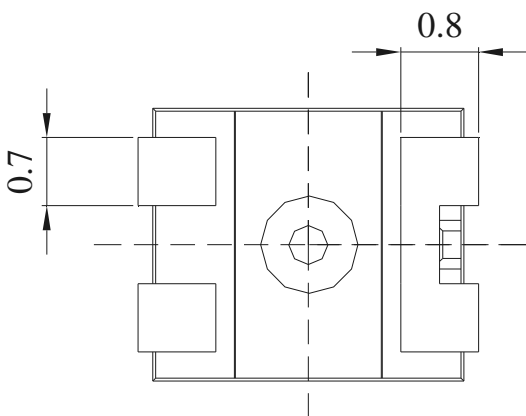

Note: Tolerances unless mentioned  $\pm 0.1\text{mm}$ . Unit = mm

**Moisture Resistant Packing Materials**

Label Explanation

- CPN: Customer's Product Number
- P/N: Product Number
- QTY: Packing Quantity
- CAT: Luminous Intensity Rank
- HUE: Dom. Wavelength Rank
- REF: Forward Voltage Rank
- LOT No: Lot Number

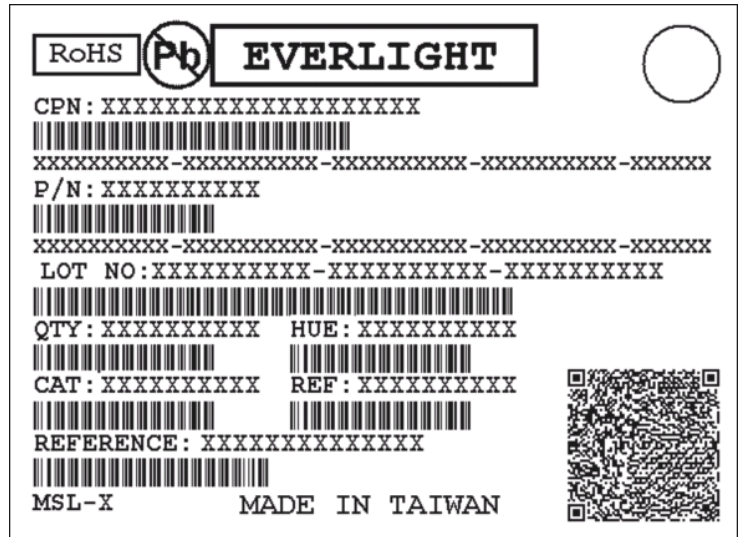

**Reel Dimensions**

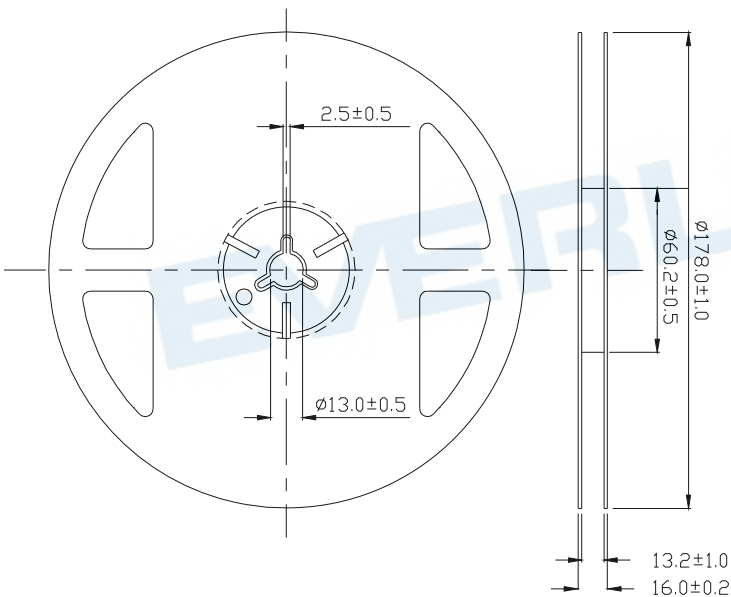

Note: Unit = mm



**Carrier Tape Dimensions: Loaded Quantity 1500 pcs Per Reel**

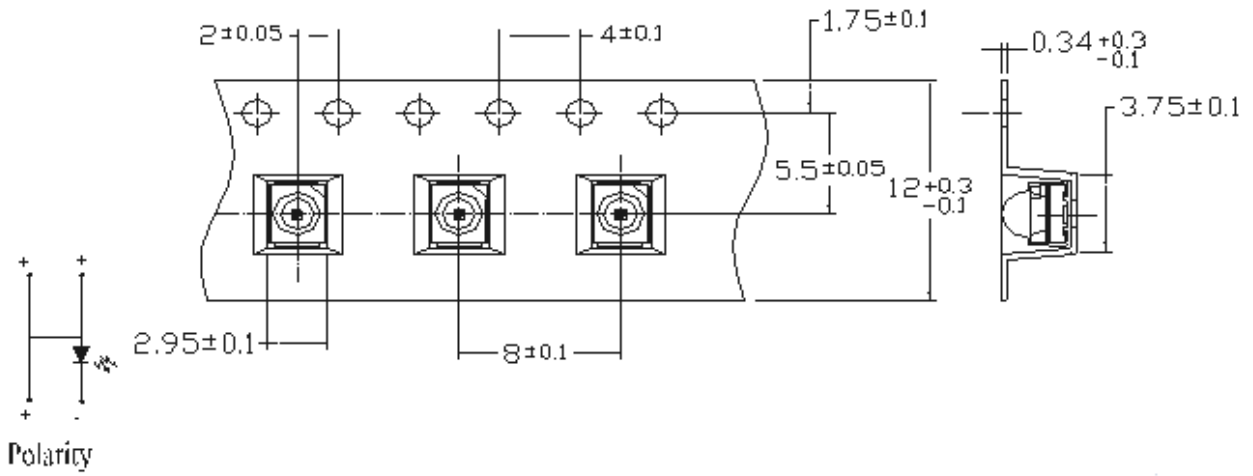

Note:  
 The tolerances unless mentioned is :  $\pm 0.1$ mm, Unit = mm

**Moisture Resistant Packing Process**

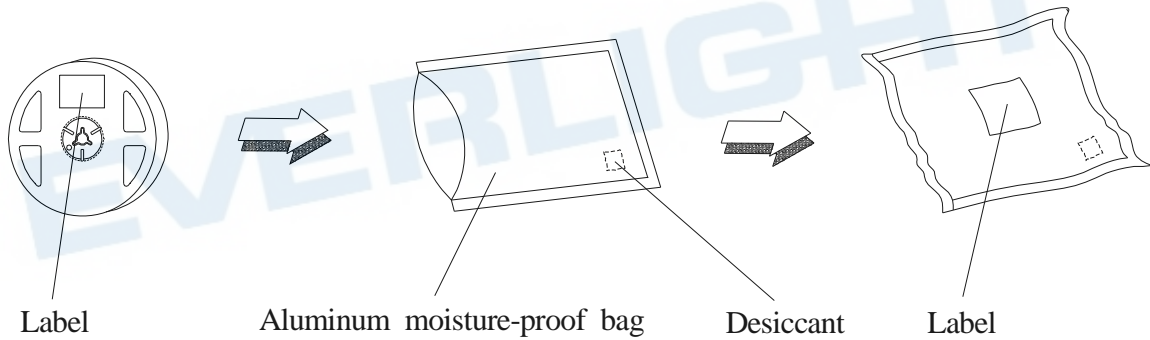

Note:  
 Tolerances unless mentioned  $\pm 0.1$ mm. Unit = mm

## Precautions For Use

### Precautions for Use

#### 1. Soldering Condition (Reference: IPC/JEDEC J-STD-020D)

##### a. IR reflow

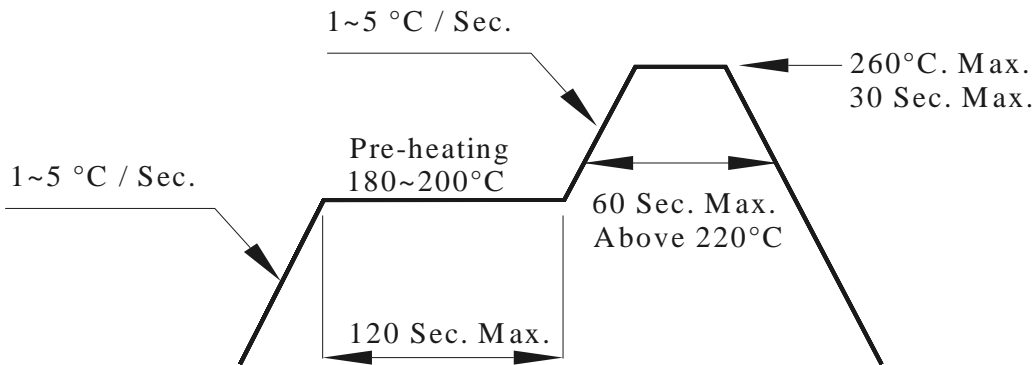

##### (B) Recommend soldering pad

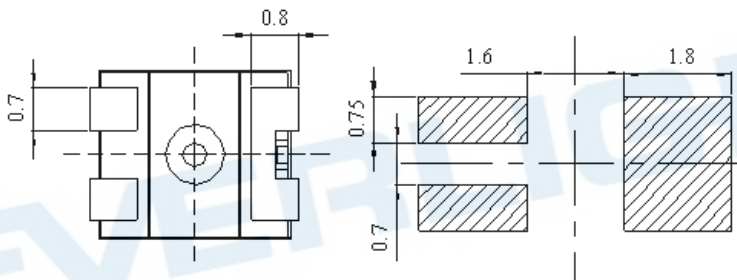

Note: Tolerances unless mentioned  $\pm 0.1$ mm. Unit = mm

#### 2. Current limiting

A resistor should be used to limit current spikes that can be caused by voltage fluctuations. Otherwise damage could occur.

#### 3. Storage

- 3.1 Moisture proof bag should only be opened immediately prior to usage.
- 3.2 Environment should be less than 30°C and 60% RH when moisture proof bag is opened.
- 3.3 If the moisture sensitivity card indicates higher than acceptable moisture, the component should be baked at min. 60deg +/-5deg for 24 hours.

#### 4. Iron Soldering

Hand soldering is not recommended for regular production. These guidelines are for rework only. Soldering iron tip should contact each terminal no more than 3 sec at 350°C, using soldering iron with nominal power less than 25W. Allow min. 2 sec. between soldering intervals.

#### 5. Usage

Do not exceed the values given in this specification.

### Application Restrictions

High reliability applications such as military/aerospace, automotive safety/security systems, and medical equipment may require different product. If you have any concerns, please contact Everlight before using this product in your application. This specification guarantees the quality and performance of the product as an individual component. Do not use this product beyond the specification described in this document.

EVERLIGHT