

PIIN/NO	ASSIGNMENT
C1	VCC
C2	RST
C3	CLK
CD	Detect Switch
C5	GND
C6	VPP
C7	I/O

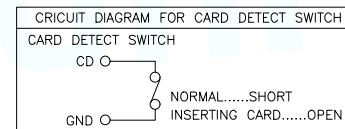

NOTES:

- MATERIAL:  
HOUSING: High Temperature Thermoplastic  
Terminal: Copper Alloy  
Shell: Stainless Steel
- PLATING:  
Terminal: 50u" Ni UNDERPLATED OVERALL  
G/F PLATED ON CONTACT AREA AND SOLDER AREA  
Shell: 30u" Ni UNDERPLATED OVERALL  
G/F PLATED ON CONTACT AREA AND SOLDER AREA
- TECHNICAL SPECIALITY:  
RATED VOLTAGE: 30V AC MAX.  
CURRENT RATING: 0.5A MAX.  
INSULATION RESISTANCE: 1000MΩ MIN  
CONTACT RESISTANCE: 50mΩ MAX  
WITHSTANDING VOLTAGE: 500V AC FOR 1 MINUTES  
OPERATING TEMPERATURE:  
-25℃~+85℃ Humidity 80% R.H MAX
- DIMENSIONS WITH MARK " \* " MUST BE MEASURE BY QC AND IPQC

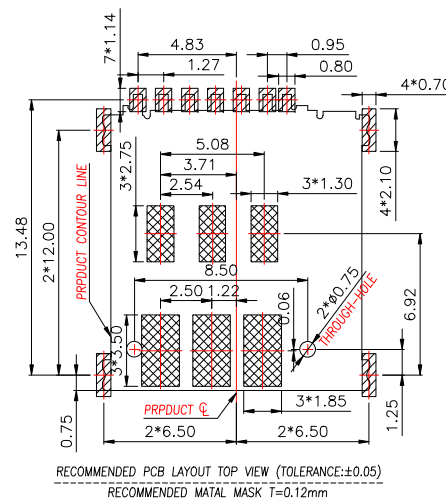
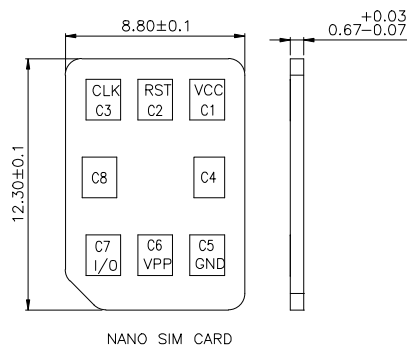

RECOMMENDED PCB LAYOUT TOP VIEW (TOLERANCE: ±0.05)  
RECOMMENDED METAL MASK T=0.12mm

- SMT SOLDER AREA
- NO PATTERN AND VIA HOLE IN THIS AREA

MANUFACTURE DWG		东莞市讯普电子科技有限公司 DongGuan XunPu Electronics Co., Ltd	TITLE: NANO SIM CARD 1.37H PUSH PUSH 有桩	
UNLESS OTHERWISE SPECIFIED TOLERANCES			PAR	SMN-303A-ACP7
DECIMALS:	ANGLES:	DWN		
X.: ±0.35	X': ±2°	CHKD		
.X: ±0.15	.X': ±1°	APVD		
.XX: ±0.10	.XX': ±0.5°	SCALE 1:1	UNIT: MM	
CUSTOMER COPY		SIZE: A4	SHEET: 1F1	
			REV: A	

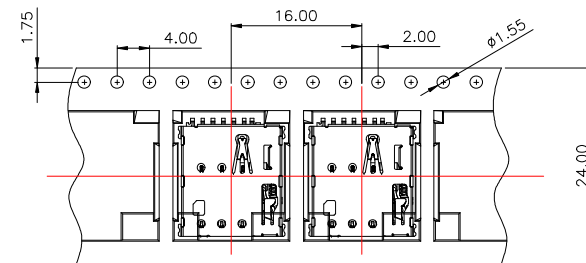
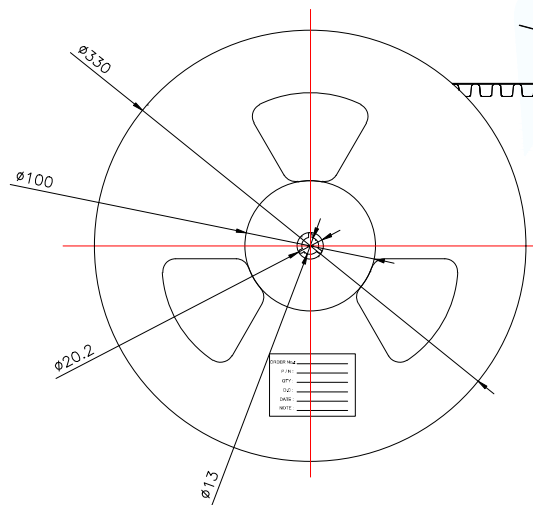
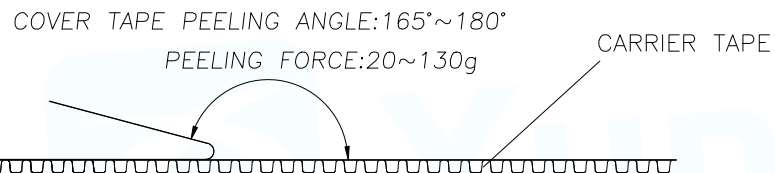
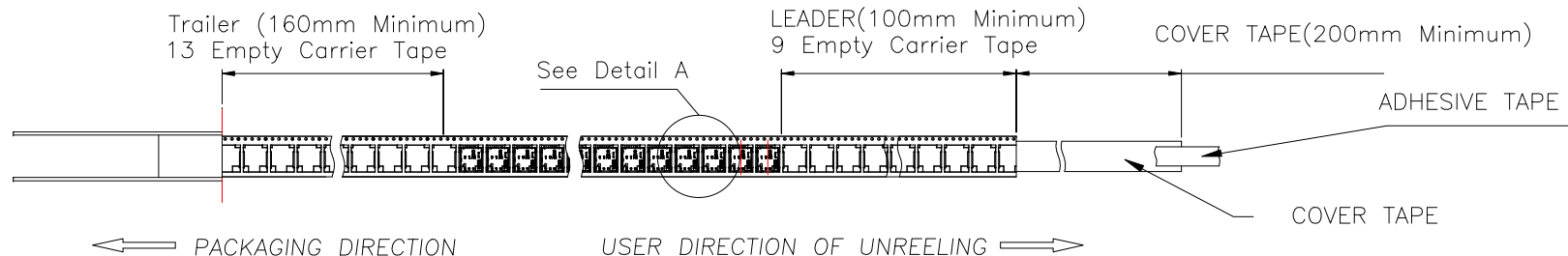

DETAIL A

1	SMN-303A-ACP7	1500	10		15000	350X350X340
ITEM	PRODUCT NO	QTY/REEL	REEL/CARTON	Kg/CARTON	QTY/CARTON	CARTON SIZE

MANUFACTURE DWG		 东莞市讯普电子科技有限公司 DongGuan XunPu Electronics Co.,Ltd	TITLE:NANO SIM CARD 1.37H PUSH PUSH 有桩		
UNLESS OTHERWISE SPECIFIED TOLERANCES			PAR	SMN-303A-ACP7	
DECIMALS:	ANGLES:	DWN			
X.: $\pm 0.35$	X': $\pm 2^\circ$	CHKD			
.X: $\pm 0.15$	.X': $\pm 1^\circ$	APVD			
.XX: $\pm 0.10$	.XX': $\pm 0.5^\circ$	SCALE1:1	UNIT:MM		
CUSTOMER COPY		SIZE:A4	SHEET:1F1	REV:A	