

FEATURES

- * Low forward voltage drop
- * High current capability
- * High reliability
- * High surge current capability
- * Epitaxial construction

MECHANICAL DATA

- * Case: Molded plastic
- * Epoxy: UL 94V-0 rate flame retardant
- * Lead: Lead solderable per MIL-STD-202, method 208 guaranteed
- * Polarity: As Marked
- * Mounting position: Any
- * Weight: 2.24 grams

VOLTAGE RANGE

45 to 200 Volts

CURRENT

10 Ampere



TO-252

Unit: mm

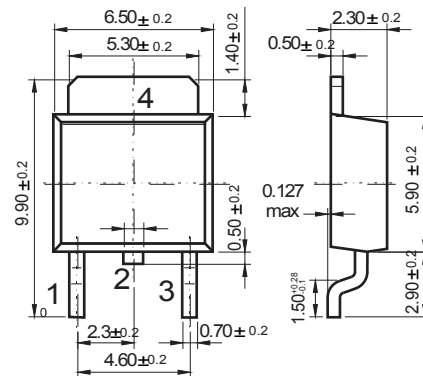

Dimensions in inches and (millimeters)

MAXIMUM RATINGS AND ELECTRICAL CHARACTERISTICS

Rating 25°C ambient temperature unless otherwise specified.
Single phase half wave, 60Hz, resistive or inductive load.
For capacitive load, derate current by 20%.

TYPE NUMBER	MBRD 1045CT	MBRD 1060CT	MBRD 10100CT	MBRD 10150CT	MBRD 10200CT	UNITS
Maximum Recurrent Peak Reverse Voltage	45	60	100	150	200	V
Maximum RMS Voltage	32	42	70	105	140	V
Maximum DC Blocking Voltage	45	60	100	150	200	V
Maximum Average Forward Rectified Current .375"(9.5mm) Lead Length at Tc=100°C	10					A
Peak Forward Surge Current, 8.3 ms single half sine-wave superimposed on rated load (JEDEC method)	150					A
Maximum Instantaneous Forward Voltage at 10A	0.55	0.70	0.85	0.90		V
Maximum DC Reverse Current at Rated DC Blocking Voltage	0.1		0.02			mA
	5		2			mA
Typical Junction Capacitance (Note1)	400					pF
Typical Thermal Resistance R _{JA} (Note 2)	8					°C/W
Operating Temperature Range T _J	-55 — +150					°C
Storage Temperature Range T _{STG}	-55 — +150					°C

NOTES:

1. Measured at 1MHz and applied reverse voltage of 4.0V D.C.
2. Thermal Resistance Junction to Ambient Vertical PC Board Mounting 0.5"(12.7mm) Lead Length.

RATING AND CHARACTERISTIC CURVES (MBRD1045CT THRU MBRD10200CT)

FIG.1-TYPICAL FORWARD CURRENT DERATING CURVE

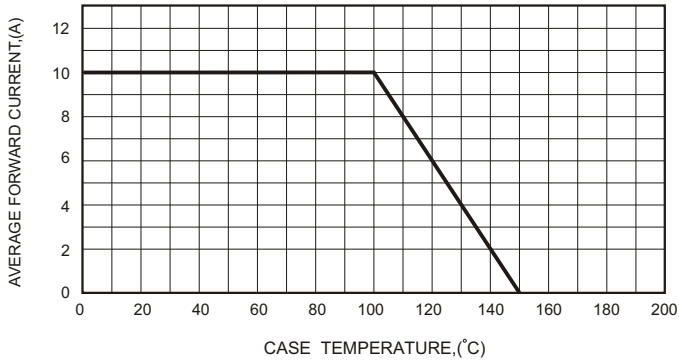

FIG.2-TYPICAL FORWARD CHARACTERISTICS

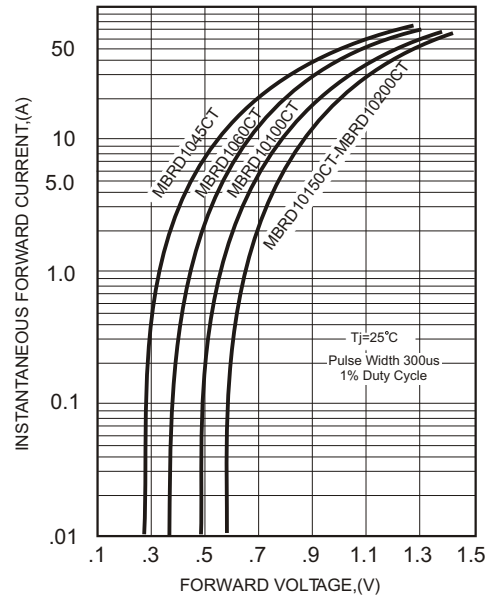

FIG.3-MAXIMUM NON-REPETITIVE FORWARD SURGE CURRENT

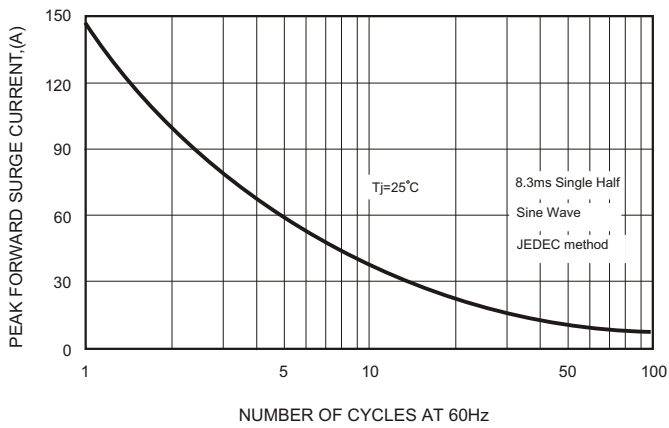

FIG.4-TYPICAL JUNCTION CAPACITANCE

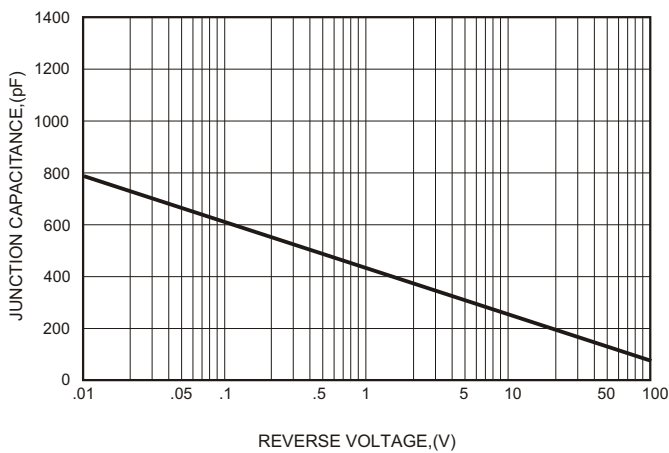

FIG.5 - TYPICAL REVERSE CHARACTERISTICS

