

WS3221C

Over-Voltage-Protection load switch with Adjustable OVLO threshold

[Http://:www.willsemi.com](http://www.willsemi.com)

Descriptions

The WS3221 is an Over-Voltage-Protection (OVP) load switch with adjustable OVLO threshold voltage. The device will switch off internal MOSFET to disconnect IN to OUT to protect load when any of input voltage over the threshold.

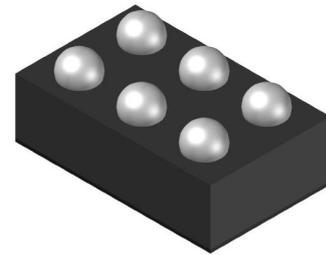

CSP-6L (Bottom View)

When the OVLO input set below the external OVLO select voltage, the WS3221 automatically chooses the internal fixed OVLO threshold voltage. The over voltage protection threshold voltage can be adjusted with external resistor divider and the OVLO threshold voltage range is 4~20V. The Over temperature protection (OTP) function monitors chip temperature to protect the device.

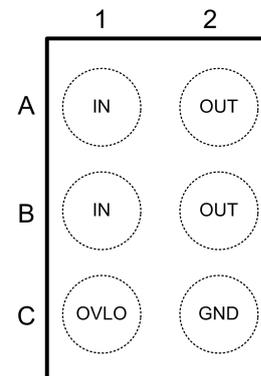

Pin configuration (Top view)

The WS3221 is available in standard CSP-6L Package. Standard products are Pb-free and Halogen-free.

Features

- Maximum input voltage : 29V
- Switch ON resistance : 28mΩ Typ.
- Ultra fast OVP response time : 50ns Typ.
- OVLO threshold voltage

Reference voltage for adjustable version
 1.2V : WS3221C with ±2.5% accuracy
 Internal threshold voltage for fixed version
 6.8V : WS3221C68 with ±2% accuracy
 10.5V : WS3221CB with ±2% accuracy
 14.0V : WS3221CE with ±2% accuracy

Applications

- Mobile Handsets and Tablets
- Portable Media Players
- Peripherals

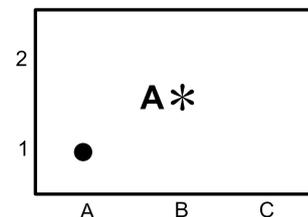

Marking

A = Device code
***** = Month code (A~Z)

Order information

Device	Marking	Package	Shipping
WS3221C-6/TR	A*	CSP-6L	3000/Reel&Tape
WS3221C68-6/TR	F*	CSP-6L	3000/Reel&Tape
WS3221CB-6/TR	B*	CSP-6L	3000/Reel&Tape
WS3221CE-6/TR	E*	CSP-6L	3000/Reel&Tape

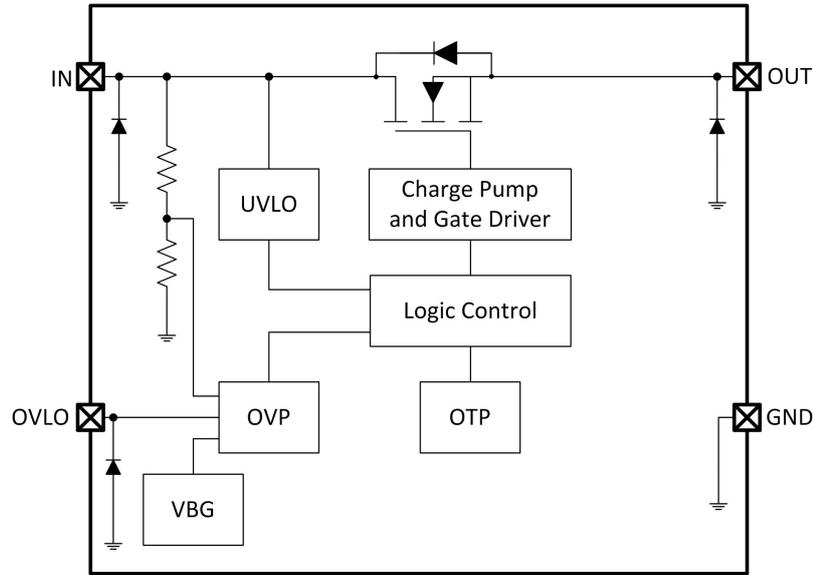
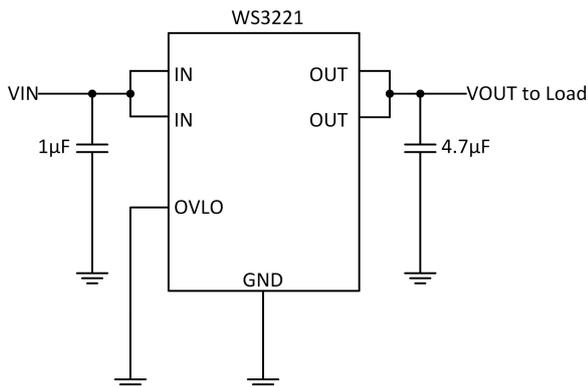
Function Block Diagram

Typical Applications

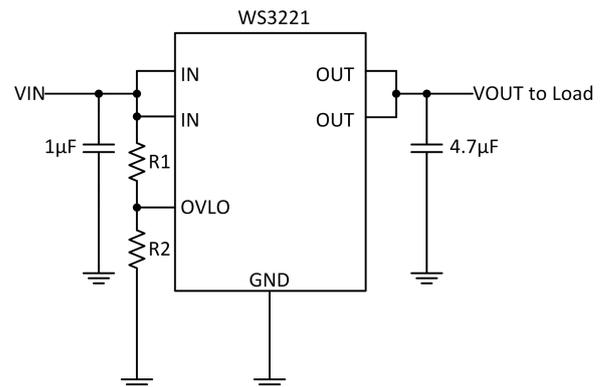
Over Voltage Protect with Internal OVLO Threshold Setting



Over Voltage Protect with External OVLO Threshold Setting

Note1: R1 and R2 are only required for External OVP, otherwise connect OVLO to GND

Note2: Recommend $10K \leq R2 \leq 50K$

Pin Descriptions

Pin No.	Symbol	Descriptions
A1, B1	IN	Switch Input and Device Power Supply.
A2, B2	OUT	Switch Output to Load.
C1	OVLO	External OVLO adjustment. Connect a resistor-divider to set different OVLO threshold, $V_{OVLO} = 1.2 \times (1 + R1/R2)$ as shown typical application diagram. Connect OVLO to GND when using the internal fixed threshold voltage.
C2	GND	Ground

Absolute Maximum Ratings

Parameter	Symbol	Value	Unit
Input voltage (IN pin)	V_{IN}	-0.3 ~ 29	V
Output voltage (OUT pin)	V_{OUT}	-0.3 ~ 22	V
Input voltage (OVLO pin)	V_{OVLO}	-0.3~15	V
MAX Continuous Output current	I_{OUT}	4	A
Switch FET Body Diode Continuous Current	I_{DIODE}	2.5	A
Body Diode Forward Peak Pulse Current*1	I_{PP}	Pulse Width=10ms	20
		Pulse Width=20μs	50
Thermal resistance	$R_{\theta JA}$	98	°C/W
Junction temperature	T_J	150	°C
Lead temperature(10s)	T_L	260	°C
Storage temperature	T_{stg}	-55 ~ 150	°C
ESD Ratings	HBM	±4000	V
	MM	±200	V

***1 Single Pulse**

These are stress ratings only. Stresses exceeding the range specified under “Absolute Maximum Ratings” may cause substantial damage to the device. Functional operation of this device at other conditions beyond those listed in the specification is not implied and prolonged exposure to extreme conditions may affect device reliability.

Recommend Operating Conditions (Ta=25°C, unless otherwise noted)

Parameter	Symbol	Value	Unit
Input voltage	V_{IN}	2.5 ~ 28	V
Ambient operating temperature	T_{opr}	-40 ~ 85	°C

Electronics Characteristics ($V_{IN}=5V$, $C_{IN}=1\mu F$, $C_{OUT}=4.7\mu F$, $T_a=25^\circ C$, unless otherwise noted)

Parameter	Symbol	Conditions	Min.	Typ.	Max.	Units
Input voltage range	V_{IN}		2.5		28	V
Quiescent current	I_Q	NO Load		110		μA
ON resistance	R_{ON}	$V_{IN}=5V$, $I_{OUT}=1A$		28	35	$m\Omega$
OVP response time	t_{OVP}	V_{IN} rising, $C_{IN}=C_L=0pF$ *1		50		ns
OVP threshold voltage	V_{OVLO_TH}	WS3221C, V_{OVLO_TH}	1.17	1.2	1.23	V
		adj. version V_{OVLO_HYS} *2		35		mV
		WS3221C68, fixed version	6.66	6.8	6.93	V
		WS3221CB, fixed version	10.29	10.5	10.71	V
		WS3221CE, fixed version	13.58	14.0	14.42	V
Adjust OVP voltage range	V_{OVLO_RANGE}	V_{IN} rising	4		20	V
External OVLO select Threshold	V_{OVLO_SELECT}		0.2		0.3	V
UVLO threshold voltage	V_{UVLO}	V_{IN} rising		2.3		V
UVLO hysteresis voltage	V_{UVLO_HYS}	V_{IN} falling		0.25		V
Turn ON time	T_{ON}	$V_{IN}>UVLO$ to $V_{OUT}=V_{IN}*90\%$ $C_L=0$		16		ms
Output discharge resistance	R_{DCHG}	$V_{IN}=5V$		220		Ω
OTP threshold temperature	T_{OTP}	$V_{IN}=5V$		150		$^\circ C$
OTP hysteresis temperature	T_{HYS}	$V_{IN}=5V$		20		$^\circ C$

*1: Guaranteed by design

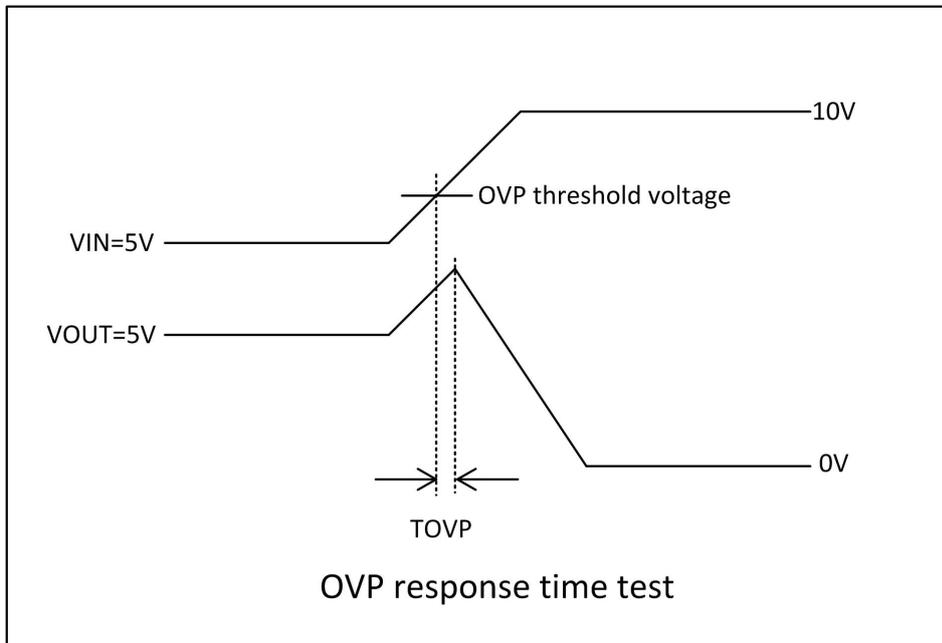

*2: If connect a resistor-divider to set different OVLO threshold, then $V_{OVLO_HYS} = 35 \times (1+R1/R2)$ mV

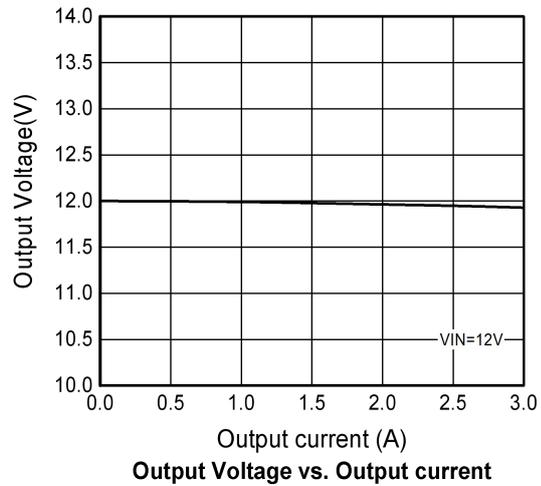
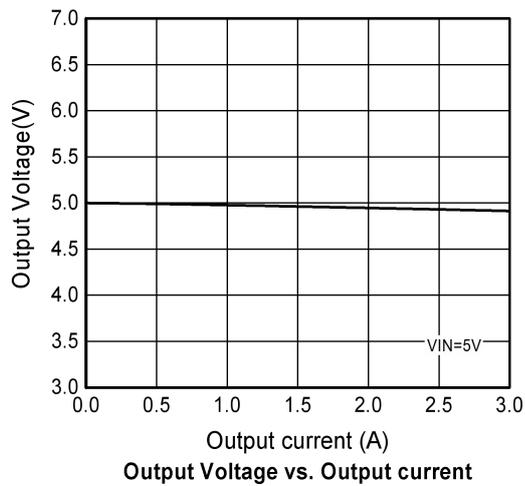
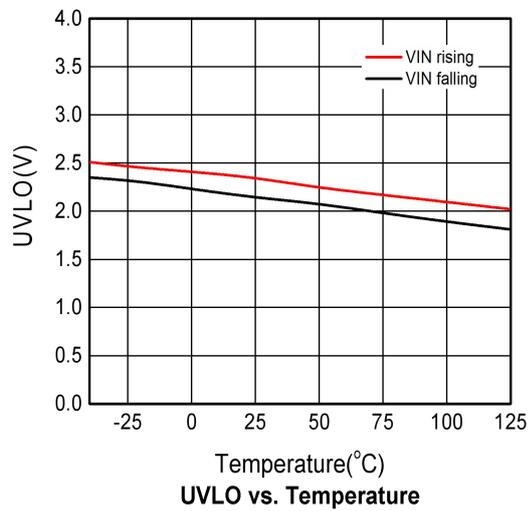
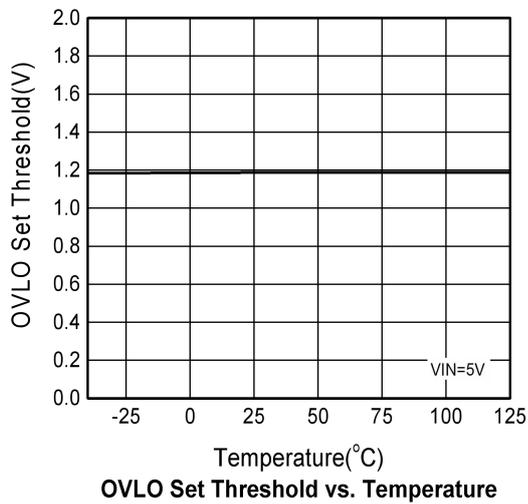
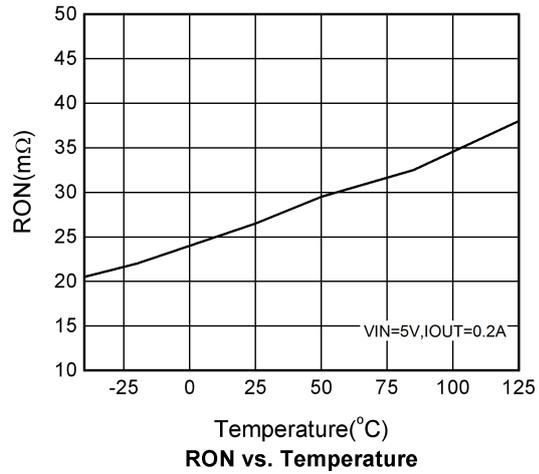
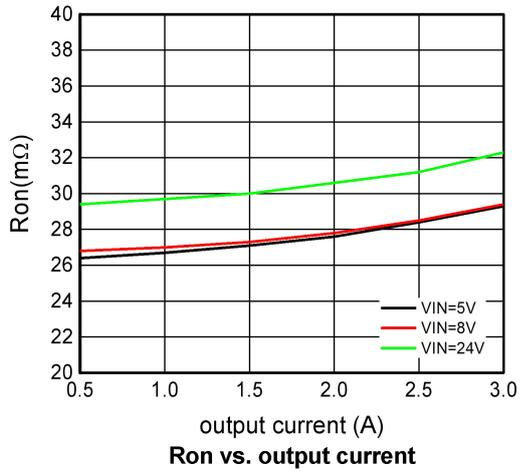
Typical Characteristics ($T_A=25^\circ\text{C}$, unless otherwise noted)

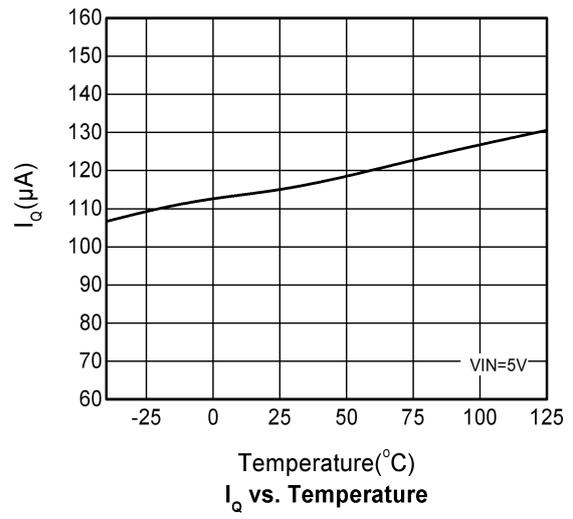
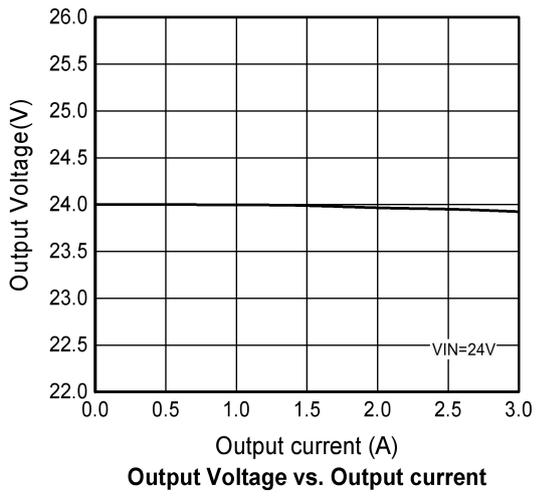

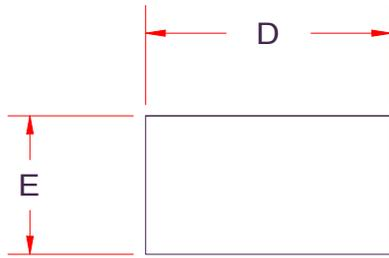
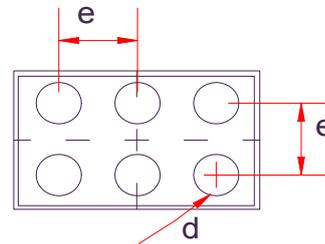
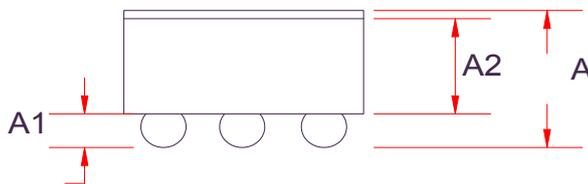
PACKAGE OUTLINE DIMENSIONS
CSP-6L

TOP VIEW

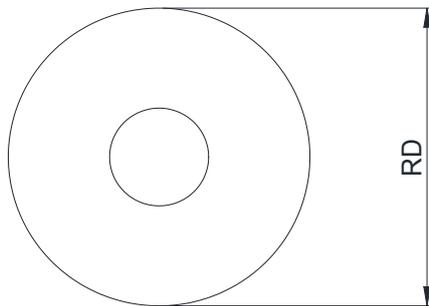
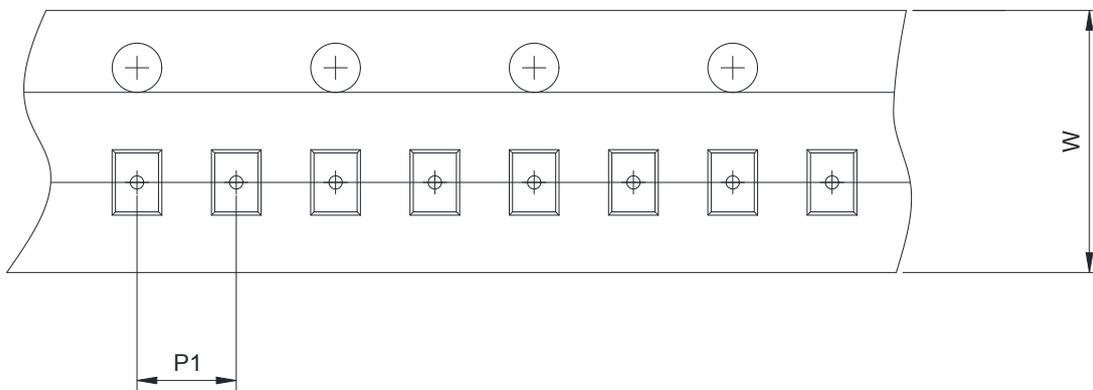
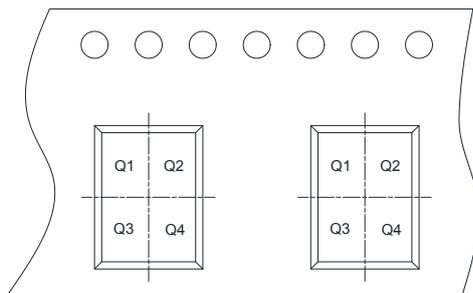
BOTTOM VIEW

SIDE VIEW

Symbol	Dimensions in Millimeters		
	Min.	Typ.	Max.
A	0.52	0.57	0.63
A1	0.16	0.19	0.22
A2	0.33	0.36	0.39
D	1.22	1.25	1.28
E	0.74	0.77	0.80
e	0.40Typ.		
e1	0.40Typ.		
d	0.19	0.23	0.27

TAPE AND REEL INFORMATION
Reel Dimensions

Tape Dimensions

Quadrant Assignments For PIN1 Orientation In Tape



 User Direction of Feed

RD	Reel Dimension	<input checked="" type="checkbox"/> 7inch	<input type="checkbox"/> 13inch
W	Overall width of the carrier tape	<input checked="" type="checkbox"/> 8mm	<input type="checkbox"/> 12mm <input type="checkbox"/> 16mm
P1	Pitch between successive cavity centers	<input type="checkbox"/> 2mm	<input checked="" type="checkbox"/> 4mm <input type="checkbox"/> 8mm
Pin1	Pin1 Quadrant	<input checked="" type="checkbox"/> Q1	<input type="checkbox"/> Q2 <input type="checkbox"/> Q3 <input type="checkbox"/> Q4