

## Description

- Proprietary processing technique produces extremely low resistance values
- Very low inductance
- Low thermal EMF
- Metallic Material
- AEC-Q101 qualified available

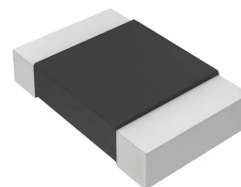

## Part Numbering System

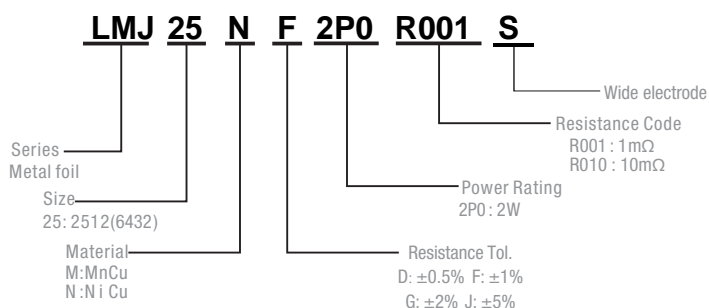

Parameter	Standard
Power Rating	1mΩ~10mΩ : 2 W
Resistance Value	1~10mΩ
Operating Temperature Range	-55 to +170°C
Component Temperature Coefficient (TCR)	± 50 ppm/°C
Maximum Working Voltage (V)	$(P \times R)^{1/2}$
Rating Current (A)	$(P / R)^{1/2}$

P=Power Rating; R=Resistance Value

## Standard Electrical Specifications

Type	Rating Power at 70°C	T.C.R. (ppm/°C)	Resistance Range(mΩ) 0.5% (D) 1.0% (F) 2.0% (G) 5.0% (J)	Material	Electrode	Operating Temperature(°C)
LMJ25	2W	50	1-10	R001-R010:MnCu R001-R010:NiCu	R001-R003:Wide R004-R10:Narrow	-55~+170°C

### Construction

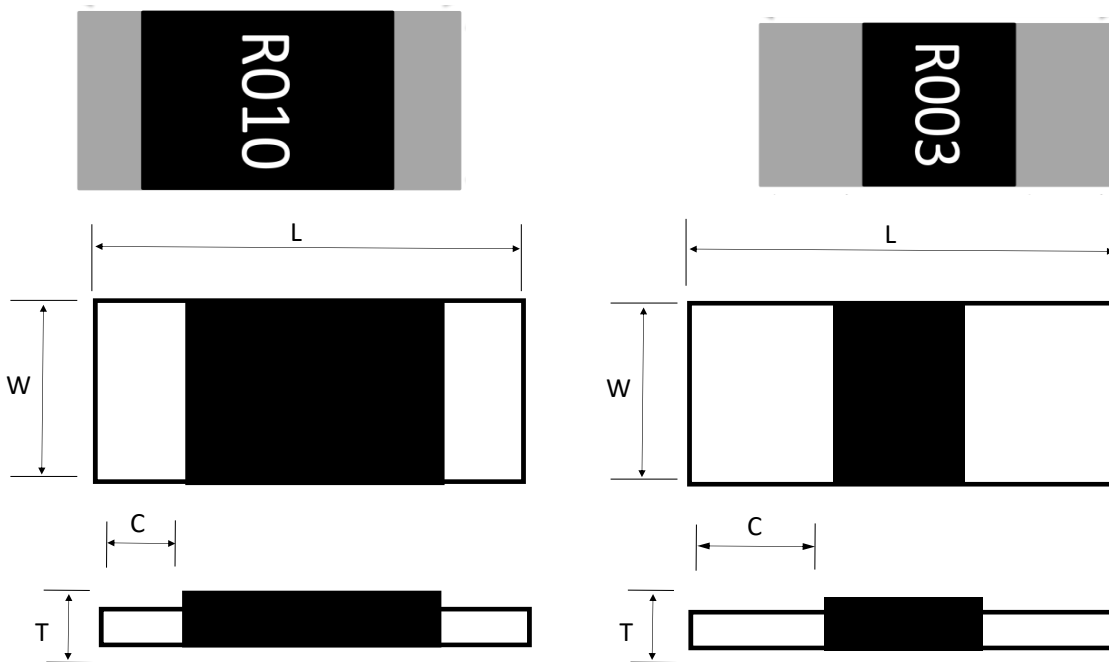

Unit: Millimeters

Type	Power	L	W	C	t
LMJ 25	2W	6.4±0.2	3.2±0.2	1.0±0.2 (Narrow)	0.7±0.2
				2.2±0.2 (Wide)	

### Recommended land pattern

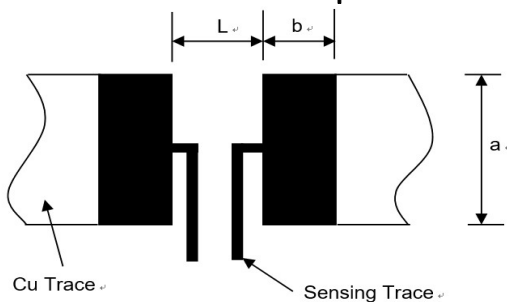

Unit: Millimeters

Resistance Range (Ω)	a	b	L
0.001-0.003(Wide)	4.0±0.1	3.1±0.1	1.3±0.1
0.004~0.010(Narrow)	4.0±0.1	2.1±0.1	4.1±0.1

### Product structure diagram

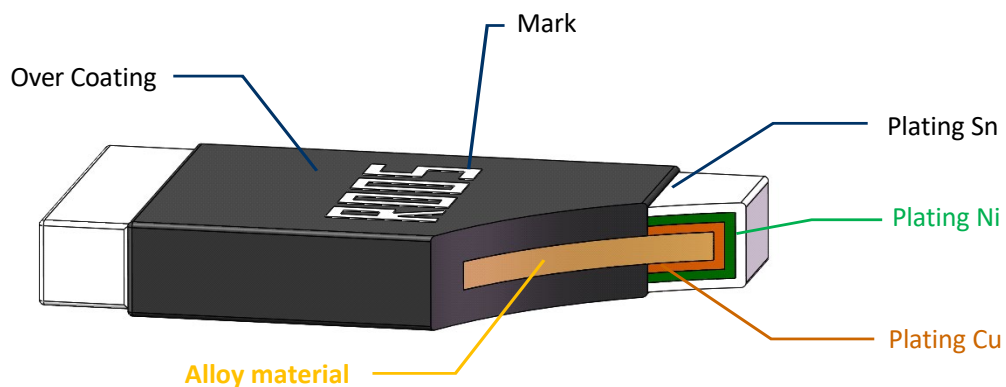

## Power Derating Curve

For resistors operated in ambient temperatures 70°C, power rating shall be derated in accordance with the curve below:

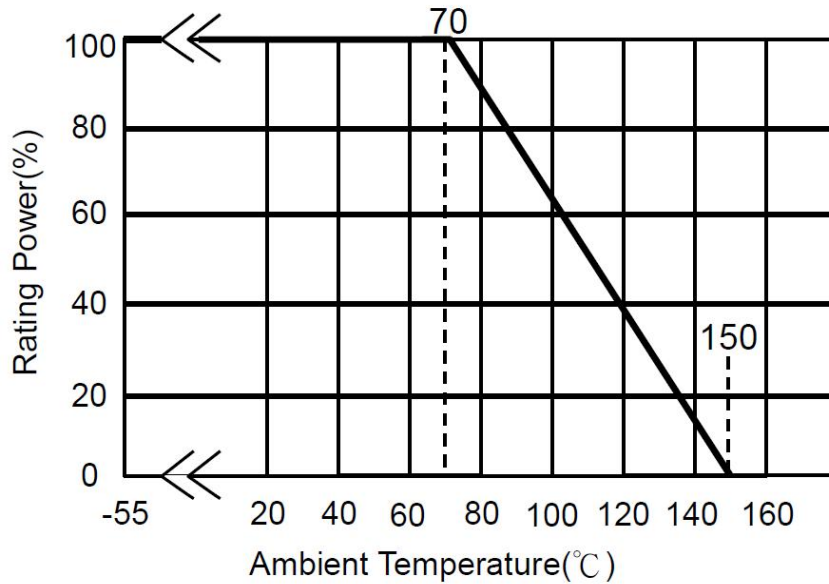

## Recommended Solder Curve

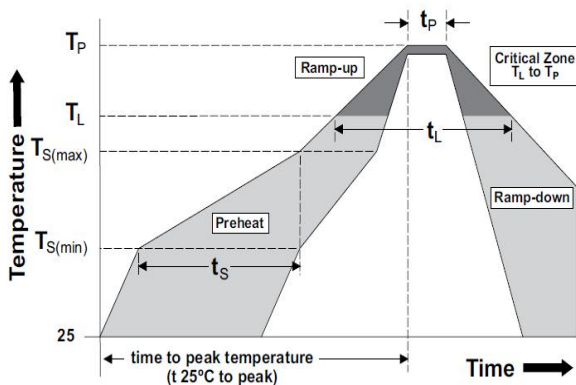

Reflow Condition		Pb – Free assembly
Pre heat	- Temperature Min (Ts(min))	150°C
	- Temperature Max (Ts(max))	200°C
	- Time (Min to Max) (ts)	60 – 120 secs
Average ramp up rate (Liquidus Temp (TL) to peak)		5°C/second max
TS(max) to TL - Ramp-up Rate		5°C/second max
Reflow	- Temperature (TL) (Liquidus)	217°C
	- Temperature (tL)	60 – 150 seconds
Peak Temperature (TP)		260°C
Time within 5°C of actual peak Temperature (tp)		20 – 40 seconds
Ramp-down Rate		5°C/second max
Time 25°C to peak Temperature (TP)		8 minutes Max.
Wave Soldering		260°C, 10 seconds max.
Hand Soldering		350°C, 5 seconds max.

## Product Characteristics

Item	Test condition/ Methods	Limited	Standard
Resistance	Measuring resistance value at room temperature 25°C±5°C	Refer to Spec	IEC60115-1 4.5
Temperature coefficient of resistance	$TCR = \frac{(R-R_0)}{R_0(T_2-T_1)} \times 10^6$ R <sub>0</sub> : resistance of room temperature R: resistance of 125°C T <sub>1</sub> : Room temperature T <sub>2</sub> : Temperature at 125°C	Refer to Spec	MIL-STD-202 Method 304
Short time Overload	Apply overload for 5 seconds and measure the resistance change rate after standing for 24 hours. 4 times the rated power for 5 seconds	≤±0.5%	MIL-R-26E
Resistance to Soldering Heat	260°C±5°C time: 12sec±0.5sec	≤±0.5%	MIL-STD-202 Method 210
Temperature Cycling	-55°C (15min)/+125°C(15min), 1000 cycles	≤±1%	MIL-STD-202 Method107G
Low temperature Storage	-55°C for 1000hours, No power	≤±0.5%	MIL-STD-26E
High Temperature Storage	125°C for 1000hours, No power	≤±1%	IEC6011501-4.25
Bias Humidity	+85°C, 85% RH, 10%bias, 1000hours	≤±0.5%	MIL-STD-202 Method103
Mechanical shock	Condition C, 100 g's, 6 msec, 3 mutually perpendicular axes, in 6 directions, three impacts each for a total of 18 times 18 shocks.	≤±0.5%	MIL-STD-202 Method 213
Vibration	The frequency varies from 10HZ to 55HZ and return to 10HZ, shall be transferred in 1 min. Amplitude : 1.5mm, 3 directions, and 12 hours	≤±0.5%	MIL-STD-202 Method 201
Operational life	70°C±2°C, 1000 hours, at rated power 1.5 hours "ON", 0.5 hours "OFF"	≤±1%	MIL-STD-202 Method 108
Moisture resistance	MIL-STD-202,method106, No power, 7b not required	≤±1%	MIL-STD-202 Method 106

## Tapping & Package

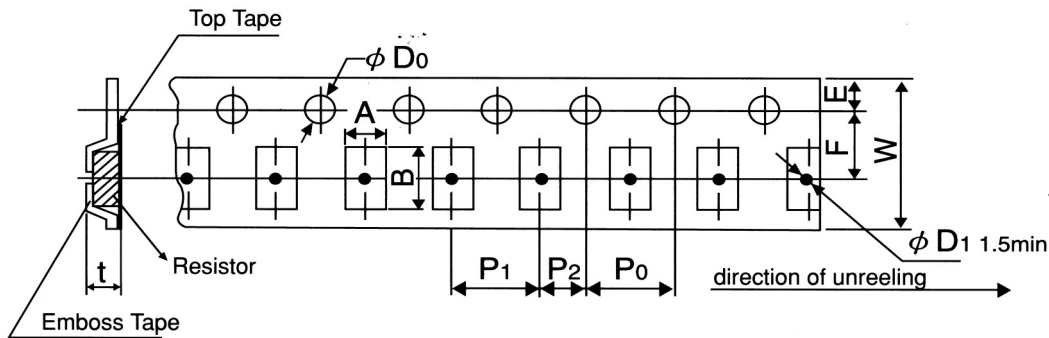

Type	Pack	A ±0.2	B ±0.2	D0 +0.5-0	E ±0.1	F ±0.05	P0 ±0.1	P1 ±0.1	P2 ±0.1	W ±0.2	D1 ±0.05	T ±0.15
2512	Emboss	3.60	6.90	1.50	1.75	5.50	4.00	4.00	2.00	12.00	1.50	1.20

## Reel Specification

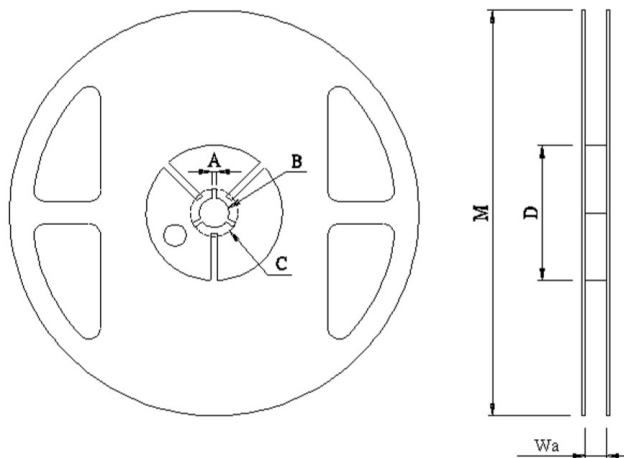

Type	A	B	C	D	M	W
2512	2.00±0.5	13.50±0.5	21.00±0.5	80.00±1.0	178.00±2.0	13.80±0.5

## Packaging

Quantity: 4, 000pcs

8mm wide tape on 178mm(7 inch)  
diameter reel -specification EIA  
Standard 481.

## Peel strength of upper belt

Stripping speed: 300 mm / min; The peel force is between 0.1N and 0.7n.

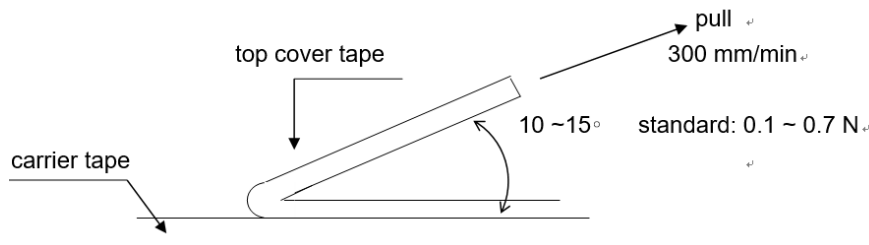

## Storage conditions & shelf life

It can be stored for 2 years under closed conditions with temperature of 5 ° C ~ 35 ° C and relative humidity of 40 ~ 75

Please avoid the following harsh environment during storage to avoid affecting the product performance and solder connectivity: the places with corrosive gases such as sea breeze, Cl<sub>2</sub>, H<sub>2</sub>S, NH<sub>3</sub>, SO<sub>2</sub> and NO<sub>2</sub> shall be stored without direct sunlight.

## Precautions for product use

When measuring the resistance value before welding, a special resistance meter with high precision shall be used. When measuring, a 4-wire probe or fixture must be used. 4. When measuring parts with a wire measuring needle, the 4 measuring needles must indeed contact the parts.

Avoid damaging the protective layer during manual welding or clamping with tweezers.

When the PCB is divided or fixed on the support, be careful to avoid excessive bending causing mechanical stress to the resistor.

It shall be used within the rated power range within the specification, especially when the power exceeds the rated value, which may affect the reliability of the product