

产品规格承认书

Specification for approval

客户名称:
Customer: _____

产品型号:
Product Model: _____ GTF 5F-1000 _____

尺 寸:
Size.: _____ 5.2X20mm 单体 _____

客户料号:
Customer Part No.: _____

供应商: _____ 苏州普罗森美电子科技有限公司
Supplier: _____ Suzhou Prosemi Electronic Technology Co., Ltd _____

供应商地 址: _____ 江苏苏州工业园区新平街388号腾飞创新园D栋701-705单元
Supplier Address: _____ Unit 701-705 Block D at Xingping Street, SIP, Jiangsu, PRC ,China _____

编 制 Prepared	审 核 Checked	批 准 Approved
王佳妮	肖逸	王泽斌

编 制 Prepared	审 核 Checked	批 准 Approved

供方签章:

SUPPLIER:

日期:

DATE: 2019.12.2



需方签章:

CUSTOMER:

日期:

DATE:

1.适用范围 / Scope of Application

本产品适用于各类电子设备电路的过流保护作用, 广泛应用于照明设备、电源设备以及适配器等领域。

This product is suitable for various kinds of electronic devices' circuit over current protection. Widely used in industrial of Lighting, Power supply and Adapter applications, etc.

2. 结构及尺寸 / Dimensions and Structure

单位: 毫米 / Unit: mm

5F Series

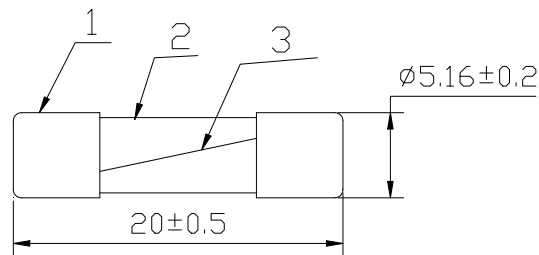

5FP Series

6.3A以下, 用 $\phi 0.6$ 引线。
8A以上, 用 $\phi 0.8$ 引线

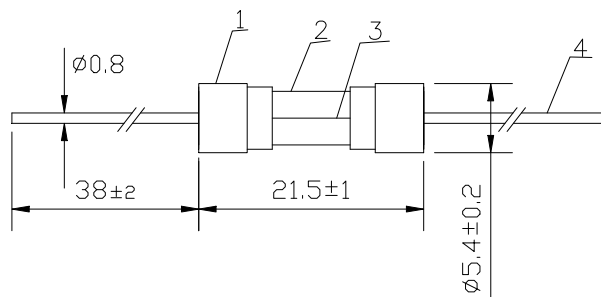

3. 材料明细 / Material Details

编号 NO.	零件名称 Part Name	材质 Material
①	铜帽 Cap	黄铜镀镍 Nickel Plated Brass
②	管体 Body	玻璃管 Glass Tube
③	熔丝 Fuse element	合金 Alloy
④	引线帽 Lead Wire	镀锡铜线 Tinned Copper Wire

4. 产品标示 / Product Marking

保险丝两端铜帽上需有下列标示。

The fuses cap shall have the following markings.

示例 For Example:

<u>P</u>	<u>15A</u>	<u>250V</u>
①	②	③

① 普罗森美工厂标识/Chevron LOGO:

② 额定电流/Rated Current(A): **A**或**mA**

③ 额定电压/Rated Voltage(V):

注意 / Note:

对于标示的大小和位置没有规定。

Size and position of the markings shall not be provided.



5. 产品特性/Product Characteristic

Rated Current	Rated Voltage	Breaking Capacity	I^2T A ² s
50mA	125V(50mA~30A) 250V(50mA~30A) 350V(50mA~20A)	35A@250Vac(50mA~1A) 10KA@125Vac(50mA~3.15A) 100A@250Vac(1.2A~3.15A) 300A@350Vac(50mA~10A) 200A@250Vac(3.5A~10A) 750A@125Vac(12A~30A) 300A@350Vac(12A~20A) 600A@250Vac(12A~30A)	0.001
63mA			0.001
100mA			0.002
125mA			0.003
160mA			0.005
200mA			0.01
250mA			0.02
315mA			0.045
400mA			0.07
500mA			0.1
630mA			0.2
800mA			0.45
1.0A			0.9
1.25A			1.3
1.6A			2.5
2.0A			5.8
2.5A			7.6
3.15A			11
4.0A			28
5.0A			40
6.3A	64		
8.0A	133		
10A	242		
12A	/		



产品规格书

文件版本 Vefision

A/0

型号 Type: 5F/5FP-1000

文件编号 No

15A			/
20A			/
25A			/
30A			/

6. 外观及形状 / Appearances and Configuration

6.1 外观不应出现显著的污点、裂纹，标识应该容易辨识。

There shall not be any remarkable stain and crack on the appearances, markings shall be easily legible.

6.2 形状：不带引线或带直线引脚小型玻璃管保险丝。

Configuration: No Lead End Cap or Axial Leaded Miniature Glass Tube Fuse.

7. 产品特性 / Product Characteristics

7.1 引脚拉力强度 / Lead Pull Strength

10 牛顿 10±1 秒 / 10N for 10±1 Seconds

7.2 引脚推力强度 / Lead Thrust Strength

2 牛顿 10±1 秒 / 2N for 10±1 Seconds

7.3 可焊性 / Solder ability

波峰焊/Wave : 260°C, ≤3s;

烙铁焊/Soldering Iron: 350±10°C, ≤3s.

7.4 耐焊接热 / Soldering Heat Resistance

波峰焊/Wave : 260°C, <10s;

烙铁焊/Soldering Iron: 350°C, <2s.

8. 电气特性 / Electrical Characteristics

8.1 实验条件: Test Condition

所有测试环境温度为 25±5°C。

All electrical test is to be conducted with the ambient air at a temperature of 25±5°C.

8.2 分断能力 / Interrupting Rating:

分断能力 Breaking Capacity::



产品规格书

文件版本 Vefision

A/0

型号 Type: 5F/5FP-1000

文件编号 No

35A@250Vac(50mA~1A)
10KA@125Vac(50mA~3.15A)
100A@250Vac(1.2A~3.15A)
300A@350Vac(50mA~10A)
200A@250Vac(3.5A~10A)
750A@125Vac(12A~30A)
300A@350Vac(12A~20A)
600A@250Vac(12A~30A)

The insulation resistance value of fuse is greater than 0.1MΩ after breaking capacity testing.

8.3 温度上升试验 / Rising Temperature Test:

通 1.0 倍额定电流，当温度稳定时（5 分钟测量 4 次，且每次测量值与平均值相差不超过 2℃）。测得熔断体任何部位的温升不得超过 75℃，周围环境温度为 25±5℃。

When the 100% times of Ampere Rating passes the fuse, after reaching thermal balance , the temperature on the fuse surface rising shall not behigher than 75℃. Note: Rising temperature= theSurface temperature-Ambienttemperature.Rising

8.4 熔断时限 / Opening Time

额定电流的% % of Ampere Rating	熔断时间 Opening Time
100%	T>4hrs
135%	T<3600s
200%	T<60s

8.5 平均时间电流曲线图 / Average Time Current Curves

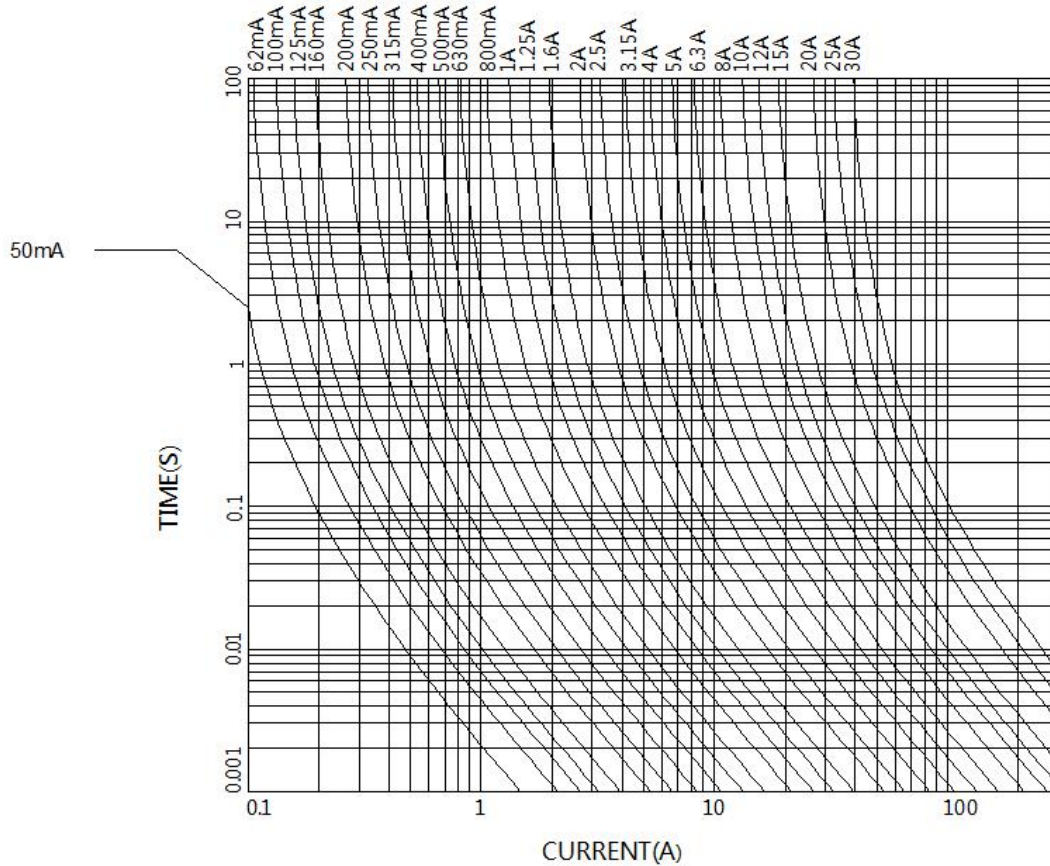

9. 环境特性 / Environmental Characteristic

9.1 使用温度范围 / Operating Temperature

-55℃~+125℃。

9.2 保存条件 Stock Condition

湿度：相对湿度 ≤ 75% 平均可以存放 3 年。

Humidity: Relative humidity ≤ 75% store 3 years in average.

9.3 若操作环境温度超出 25±5℃ 范围，在选用保险丝规格时，需考虑操作环境温度对保险丝的影响，请参照如下：温度-电流曲线图。

When choosing the fuse's specification, if the operating environmental temperature beyond the scope from 20~30℃, engineer should consider the environmental temperature's affection to fuses. Please refer: Temperature Rerating Curve:

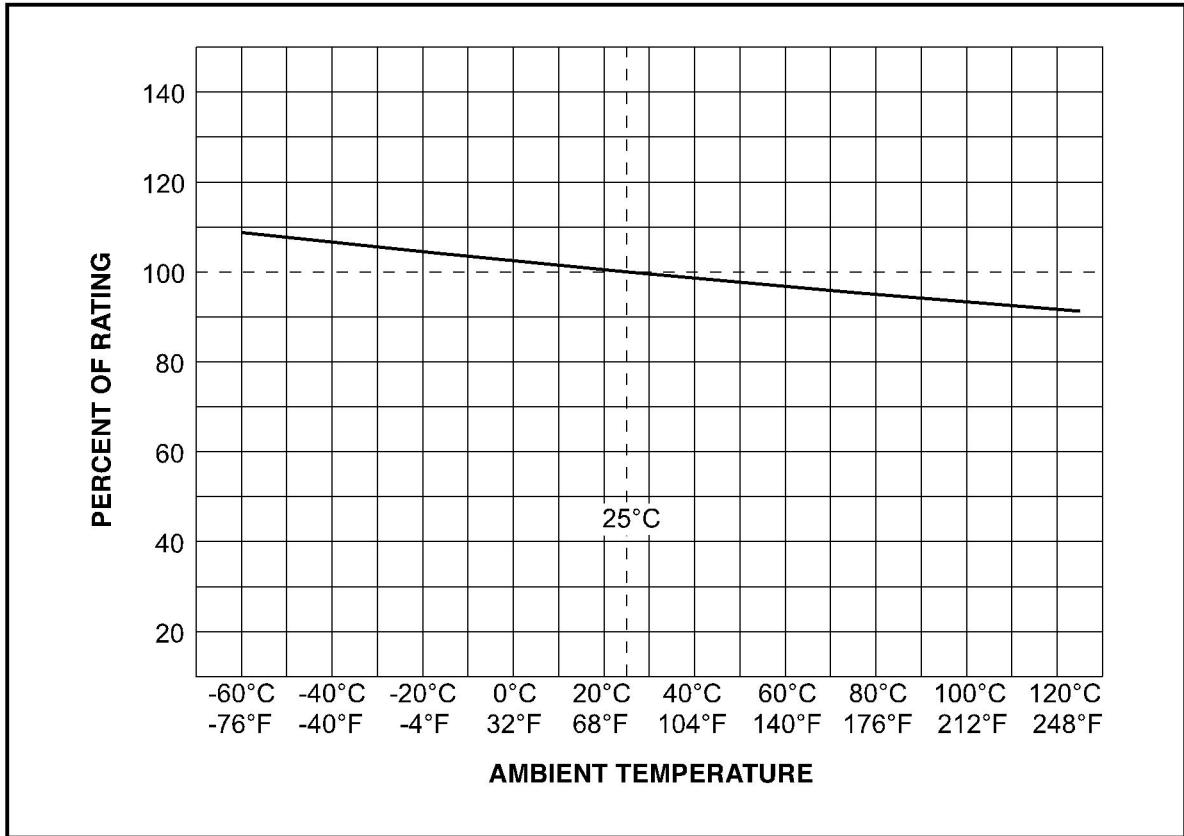

10. 安装建议 / Installation Recommendations

10.1 建议按照如下示意图方式进行安装。

Propose installation way as following picture.

A、带引线卧式安装

Axial Leaded Horizontal installation

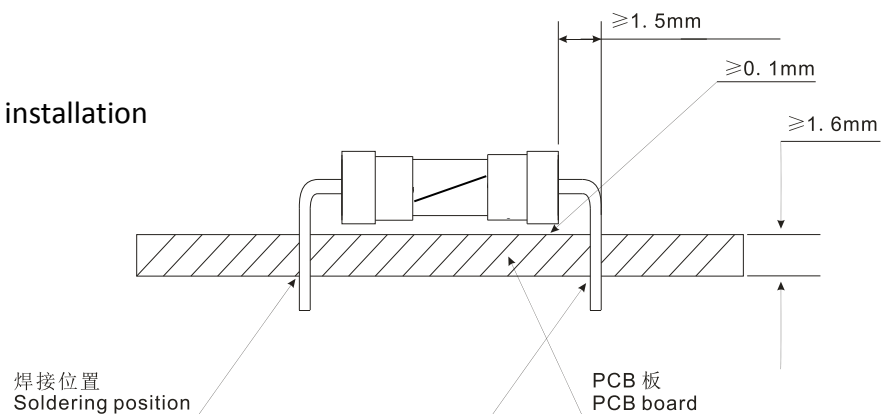

B、带引线立式安装

Axial Leaded Vertical installation

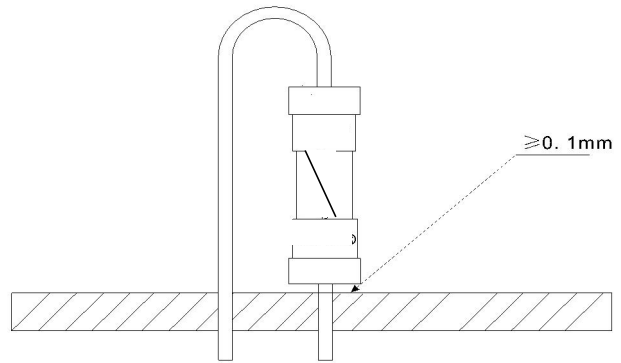

C、带引线立式安装

Axial Leaded Vertical installation

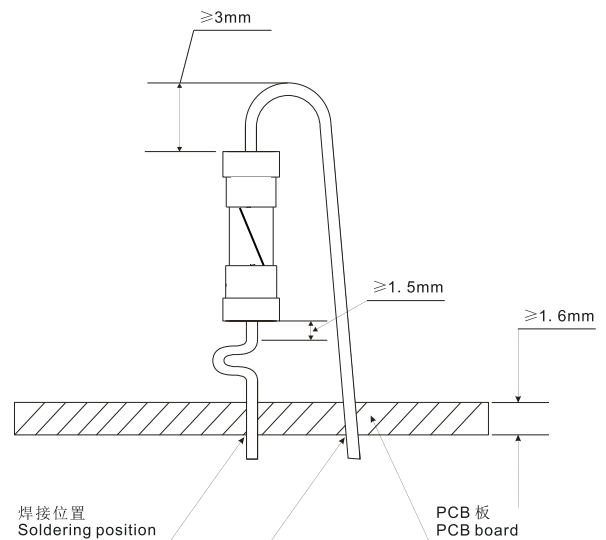

10.2 建议焊接参数 / Recommended Soldering Parameters

A. 波峰焊参数 / Wave Parameters:

锡炉温度 / Solder Pot Temperature: 260°C ±10°C

焊接时间 / Solder Dwell Time: 2~5s

B. 手工焊参数 / Hand-Solder Parameters:

烙铁温度 / Solder Iron Temperature: 350±5°C

焊接时间 / Heating Time: 3s Max

11. 包装 / Packaging

11.1 包装袋/盒印明下列标示: / The following items indicated on the label:

产品料号、额定(电压、电流)、分断类型及安规名称。



产品规格书

文件版本 Vefision

A/0

型号 Type: 5F/5FP-1000

文件编号 No

Catalog number, ratings (voltage, current), interrupting type and safety mark.

包装材料均符合 RoHS/REACH/HF 的环保要求，且包装材料不会和零件发生化学反应，造成不良。

The packing material conforms to ROHS/REACH/HF environmental protection request.

And the packing materials will not have the chemical reaction with the components.

11.2 包装数量 / Packing Quantity

每胶袋 200 个保险丝 / Bulk 200 pcs in per poly bag;

每盒 5 胶袋 1 个内盒 / 5poly bags in per inner box;

每 10 个内盒 10 个外箱 / 10 inner boxes in per outer carton