

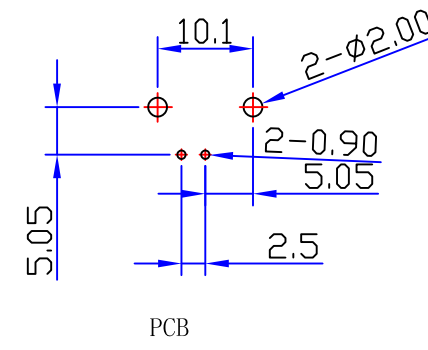

Product NO.		DOSIN-801-0045		
REV	DESCRIPTION	DWN	DATE	APPROVEN
A	First issue	JIM	2012/11/02	John kine

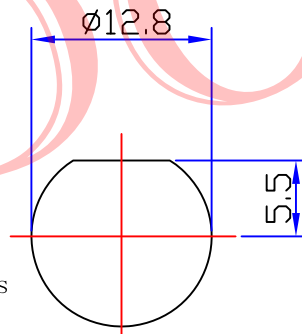
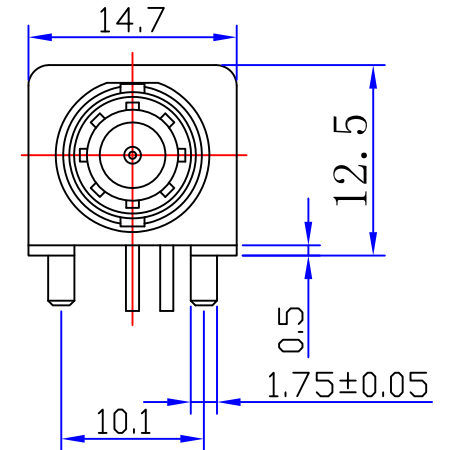
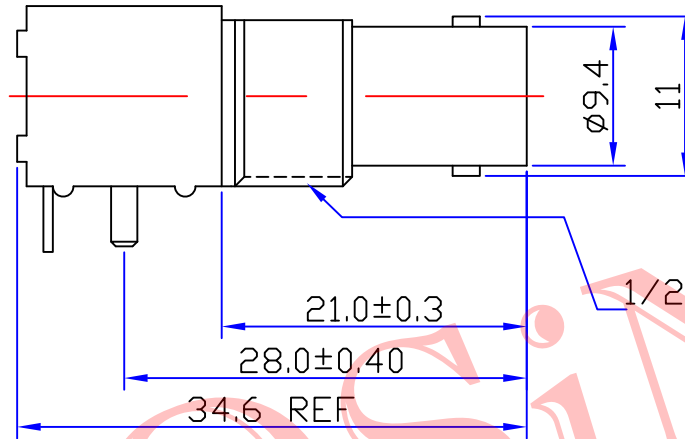
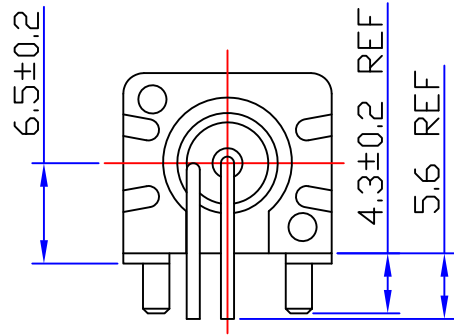

Specifications

Impedance: 75 Ohms
 Frequency Range: DC~3G
 VSWR: 1.3MAX
 Working Voltage: 500V rms @ sea level
 Insulation Resistance: 5000 Ohms min
 Temperature Range: -55°C TO +155°C
 Relative Temperature: ≤95% (40° C ± 2° C)
 Drawings products are in line with ROHS standards

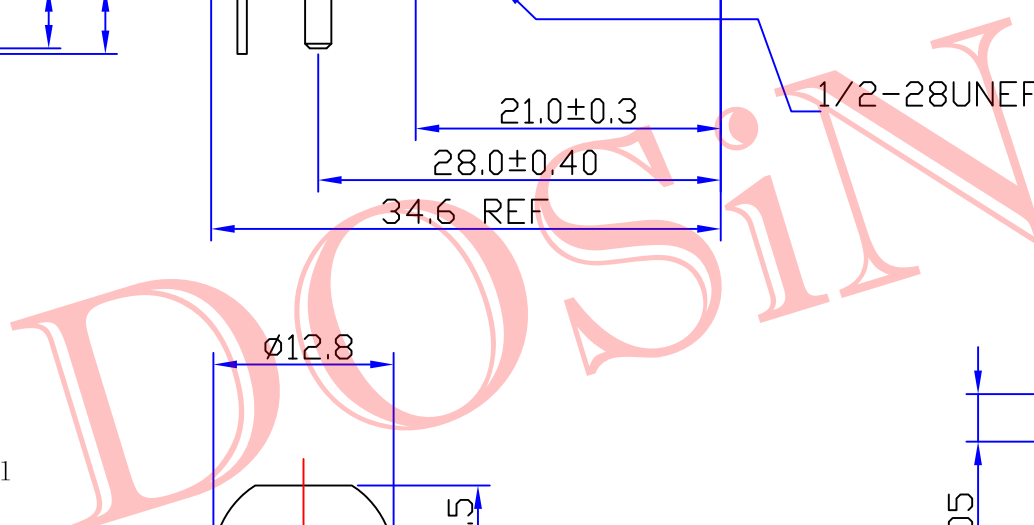

1	Body	Zinc	NI:80-120u"
2	Center contact	Brass	AU:1u"
3	Lead	Iron	AU:1u"
4	Fixed footrest	Iron	NI:80-120u"
5	Insulator	POM	White
6	Fixed mount	PBT	BLACK
7	Washer	Brass	NI:80-120u"
8	Hex nut	Brass	NI:80-120u"
9			
10			
NO	Component Number	Material	Finish

NOTE:
 DRAWN: Zelin. Zhang 2012/11/10
 CHECKED:
 APPROVALS: John Kine 12/04.2012

Tolerance	0-6 ±0.20 6-30 ±0.30 30-120 ±0.5 Angular ±2°
View	
UNIT	MM
SCALE	1:1

Dosin Industrial(H.K)Co.Ltd
 东莞市德索五金电子制品有限公司
Dosin Hardware Electronics Co.,Ltd
 E-mail: dosin2005@163.com
 dosin2005@dosin-china.com
 Web: http://www.dosinconn.com
 TEL: (0086) 769-81153906
 FAX: (0086) 769-81875836

Name: BNC BLACK JACK CONNECTOR (12.5MM)
 SIZE A Product NO. DOSIN-801-0045 REV B
 DateTime 2012/11/02 CAD FILE D/company drawings/BD SHEET: 1 OF 1