

主要技术规格:

1. 额定值: 50mA DC12V
2. 接触电阻:  $\leq 50m\Omega$
3. E(操作力):  $250 \pm 40gf$
4. 行程:  $0.3 \pm 0.1mm$
5. 绝缘电阻:  $\geq 100M\Omega$
6. 抗电强度: 250V 50HZ 1Min.
7. 寿命: 100,000 Cycles
8. 防水等级: IP67
9. 防银迁移: 60V, 85°C, 90%RH/60H

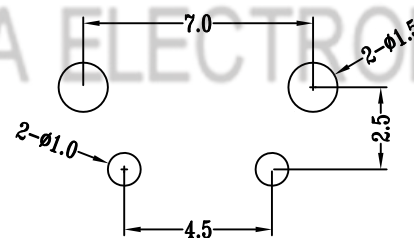
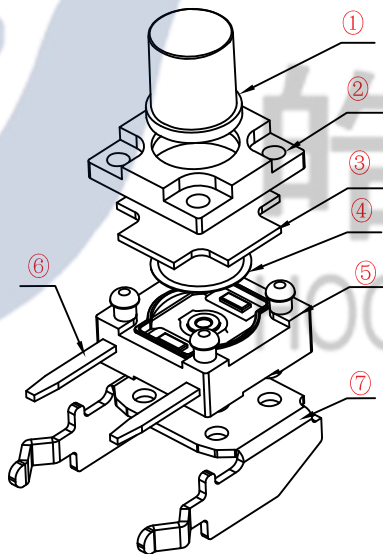
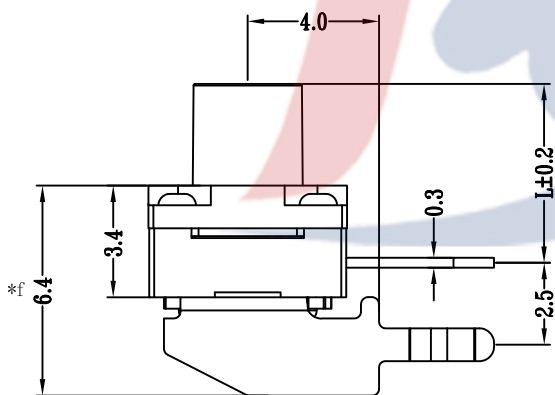
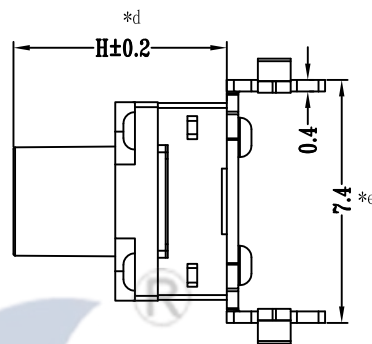
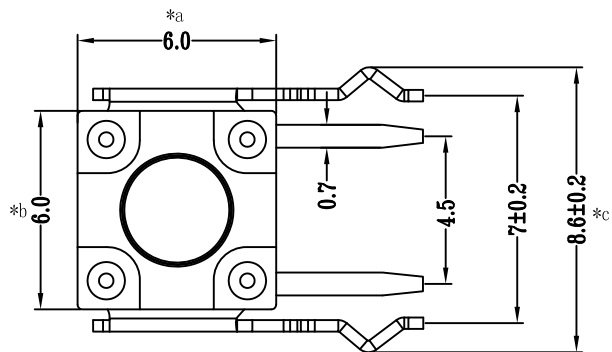

PCB. 焊接图

操作力:  $E=250 \pm 50gf$

H	L
4.3	2.95
4.5	3.45
5.0	3.95
5.5	4.45
6.0	4.95
6.5	5.45
7.0	5.95
7.5	6.45
8.0	6.95
8.5	7.45
9.0	7.95
9.5	8.45
10.0	8.95

NO.	PART NAME	MATERIAL	QTY	FINISHING	TOLERANCE UNLESS SPECIFIED		NO		DATE	REVISIONS		BY	APPD
7	FRAME	BRASS	1	Sn-Plated	UP TO 5mm: $\pm 0.1$	ANGULAR	1						
6	TERMINAL	BRASS	2	Ag-Plated	ABOVE 5mm: $\pm 0.2$	$\pm 1^\circ$	NO						
5	CASE	PPA	1	BLACK	TITLE: TACT SWITCH		UNIT: MM	ROHS COMPLIANT		DWN			
4	REED	SYS301	1	Ag-Plated	MODEL: TC-00100FSA-050E		SCALE: 1:1			CHK'D			
3	WATERPROOF PAD	RUBBER	1	BLACK	HAOYU (HONGKONG) LIMITED 皓宇(香港)有限公司					APPD			
2	COVER	PPA	1	BLACK									
1	BUTTON	PPA	1	BLACK									
					PRO. AGL:						REV: A0		