

SECT:A-A

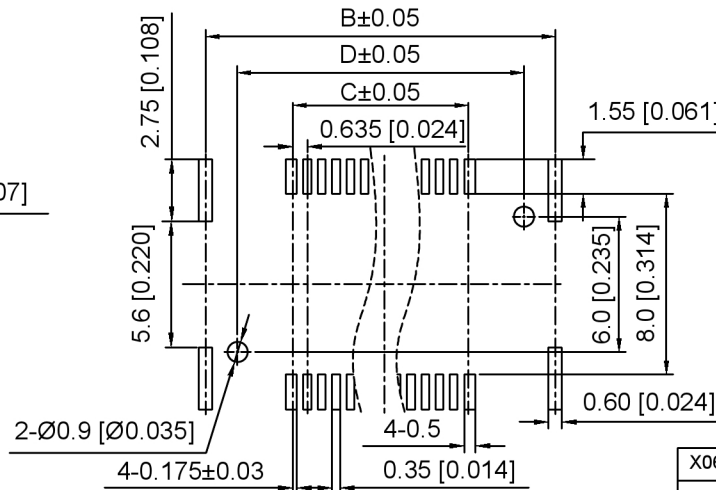
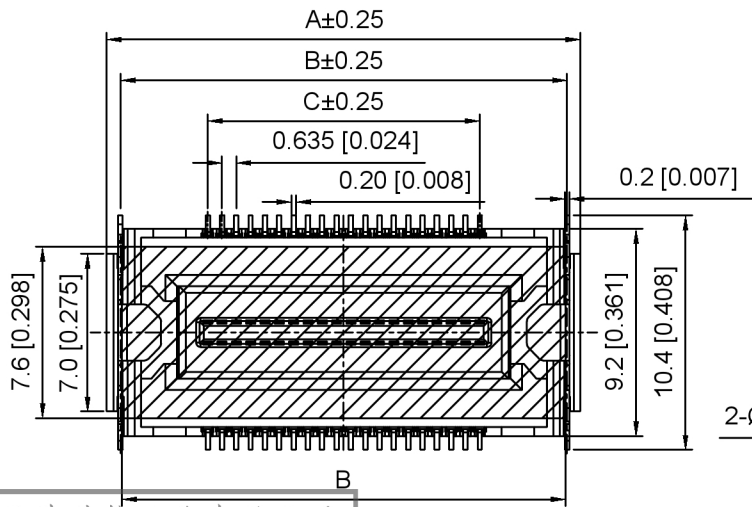
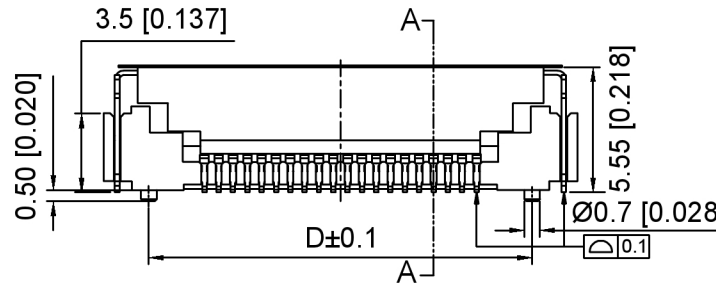
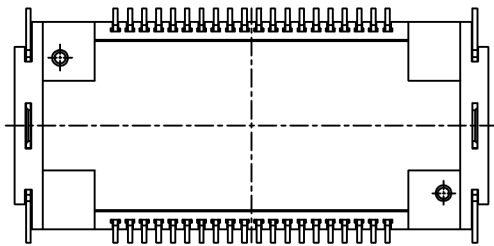
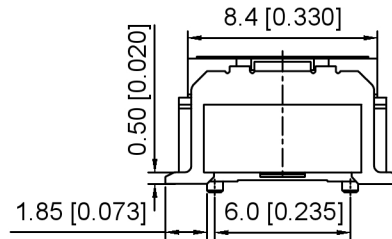

PCB LAYOUT

Specifications:

规格:

Voltage rating:50V AC/DC

额定电压: 50V AC/DC

Current rating:0.5A AC/DC

额定电流: 0.5A AC/DC

Withstanding voltage:200V AC/minute

耐受电压: 200V AC/分钟

Temperature range:-40°C-+105°C

温度范围: -40°C-+105°C

Insulation resistance:500MΩ Max

绝缘电阻: 500MΩ Max

Contact resistance:20mΩ Max

接触电阻: 20mΩ Max

X0635	W	V	S	-XX	X	S-	LP	V01
①	②	③	④	⑤	⑥	⑦	⑧	⑨

- 1.Series No
- 2.Category:W-Wafer
- 3.Welding Board Angle:V-Stright 180°
- 4.Welding Way:S-SMT
- 5.Row No.Pin No:XX-20~100P
- 6.Height:A=5.55mm:
- 7.Special No:S-With positioning column
- 8.Material:LP-LCP UL94V-0
- 9.Plating:V01-Gold paltd 4u" MIN

Poles	Dimensions(mm)			
	A	B	C	D
20	14.650	13.450	5.715	10.650
30	17.825	16.625	8.890	13.825
40	21.000	19.800	12.065	17.000
50	24.175	22.975	15.240	20.175
60	27.350	26.150	18.415	23.350
70	30.525	29.325	21.590	26.525
80	33.700	32.500	24.765	29.700
90	36.875	35.675	27.940	32.875
100	40.050	38.850	31.115	36.050

X0635WVS-XXXS-LPV01	LCP	Phosphor Bronze	X0635F
PART NO	Material	Material(Pin)	Suitable XKB Housing

广东星坤科技股份有限公司

ΔX	日期
ΔX	日期
ΔX	日期
MARK	DESCRIPTION

ANGLAR	±5°
L ≤ 4	±0.2
4 < L ≤ 16	±0.3
16 < L ≤ 63	±0.4
L > 63	±0.5
UNSPECIFIED TOLERANCES	



DSND	SCALE: N/A	MODEL TYPE: 0.635mm BTB Connector
DWN	VIEW:	PART NO.: X0635WVS-XXXS-LPV01
CHKD	UNIT: mm/in	DWG NO.: X-X0635WVS-XXXS-LPV01
APPD	SIZE: A4	

文件工程章

REVISIONS	UNSPECIFIED TOLERANCES
www.helloxkb.com www.helloxkb.cn www.xk-dg.cn	

XKB INDUSTRIAL PRECISION CO.,LIMITED		
WEIGHT	SHEET	REVISION
	1/1	A0