

# SUNWAY R CHIP DATASHEET



## Metal Current Sensor SD Series

Tolerance :  $\pm 1\%$  /  $\pm 2\%$  /  $\pm 5\%$

Sizes : 2512

*RoHS compliant & Halogen free*



# CATALOGUE

1. ORDERING INFORMATION.....	1
2. MARKING AND CONSTUCTION.....	2
3. DIMENSION AND ELECTRICAL CHARACTERISITCS.....	3
4. FUNCTION DESCRIPTION.....	4
5. FOOTPRINT AND SOLDERING PROFILES.....	5
6. PACKING STYLE AND PACKAGING QUANTITY.....	6
7. TESTS AND REQUIREMENTS.....	8
8. REVISION HISTORY.....	9
9. SUNWAY CONTACT.....	10

# 1. ORDERING INFORMATION

## SCOPE

This specification describes SD series current sensor - low TCR with lead-free terminations made by metal substrate.

## APPLICATIONS

- Consumer goods
- Computer
- Telecom / Datacom
- Industrial / Power supply
- Alternative Energy
- Car electronics

## FEATURES

- Halogen Free Epoxy
- AEC-Q200 qualified
- Halogen-free Epoxy
- RoHS compliant
- Reduce environmentally hazardous wastes
- High component and equipment reliability
- Non-forbidden materials used in products/production
- Low resistances applied to current sensing
- Anti-sulfur

## ORDERING EXAMPLE

The ordering code of a SD 2512 3W Chip resistor, TCR100 , value 0.001  $\Omega$  with  $\pm 1\%$  tolerance, supplied in 7-inch embossed plastic tape reel is: SD2512FR001F3WPKH

## ORDERING INFORMATION-GLOBAL PART NUMBER

Global part numbers are identified by the series, sizes, tolerance ,packing type, temperature coefficient, taping reel and resistance value.

## GLOBAL PART NUMBER

<b>SD</b>	<b>XXXX</b>	<b>X</b>	<b>XXXX</b>	<b>X</b>	<b>XX</b>	<b>X</b>	<b>XH</b>
	(1)	(2)	(3)	(4)	(5)	(6)	(7)

### (1) SIZE

2512

### (2) TOLERANCE

F= $\pm 1.0\%$   
G= $\pm 2.0\%$   
J= $\pm 5.0\%$

### (3) RESISTANCE

Example:  
U500 = 0.0005 $\Omega$   
R004 = 0.004 $\Omega$

### (4) TEMPERATURE COEFFICIENT OF RESISTANCE

E= $\pm 50$ ppm  
F =  $\pm 100$ ppm  
J =  $\pm 350$ ppm

### (5) POWER

3W

### (6) CONTROL CODE

N:Lead Free, P:Total Lead Free

### (7) PACKAGING TYPE & PRODUCT CODE

K = 07" Embossed plastic tape  
H = Default code

## 2. MARKING AND CONSTRUCTION

### MARKING

SD2512

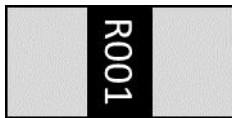

The "R" is used as a decimal point; the other 3 digits are significant  
SD2512 (3W) : 0.5mΩ to 4mΩ

Value=0.001Ω

### CONSTRUCTION

The resistors are constructed using outstanding TCR level material , which makes Sunway SD resistors excellent for current sensing application in battery charger circuit& DC-DC convergent. The composition of resistive material is adjusted to give the approximate required resistance and is covered with a protective coating. Marking is printed on the top side of the resistor.Finally ,the three external terminations (Cu/Ni/matte Tin) are added , as shown in Fig.

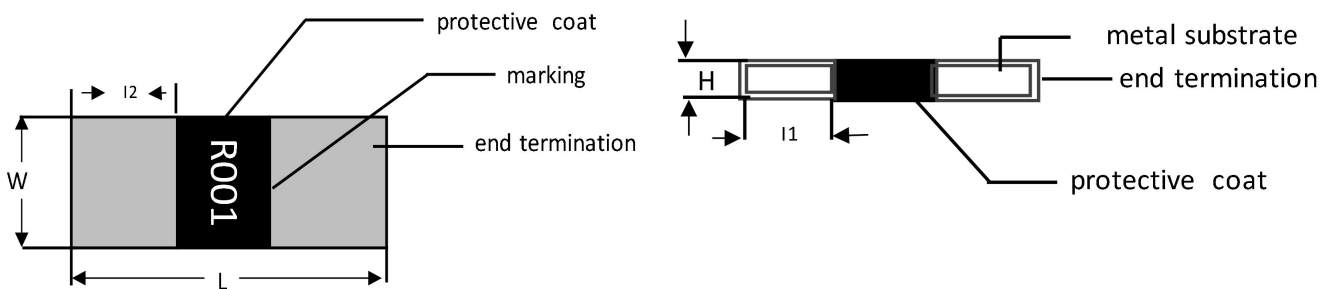

## 3.DIMENSION AND ELECTRICAL CHARACTERISTICS

### DIMENSION

TYPE	RESISTANCE RANGE	L(mm)	W(mm)	H(mm)	l1(mm)	l2(mm)
SD2512	$0.5\text{m}\Omega \leq R \leq 4\text{m}\Omega$	$6.40 \pm 0.20$	$3.20 \pm 0.20$	$0.80 \pm 0.20$	$2.20 \pm 0.20$	$2.20 \pm 0.20$

Note:

1. For relevant physical dimensions ,please refer to construction outlines.
2. Please contact with sales offices , distributors and representatives in your region before ordering.

### ELECTRICAL CHARACTERISTICS

TYPE	POWER RATING	TOLERANCE	RESISTANCE RANGE	TCR
SD2512	3W	1%/2%/5%	$0.5\text{m}\Omega \leq R < 1\text{m}\Omega$	$\pm 350\text{ppm}/^\circ\text{C}$
SD2512	3W	1%/2%/5%	$1\text{m}\Omega \leq R < 2\text{m}\Omega$	$\pm 100\text{ppm}/^\circ\text{C}$
SD2512	3W	1%/2%/5%	$2\text{m}\Omega \leq R \leq 4\text{m}\Omega$	$\pm 50\text{ppm}/^\circ\text{C}$

## 4. FUNCTIONAL DESCRIPTION

### FUNCTIONAL DESCRIPTION

#### OPERATING TEMPERATURE RANGE

SD Range: - 55°C to +170°C

#### POWER RATING

Standard rated power at 70°C:

For detail power value, please refer to Table .

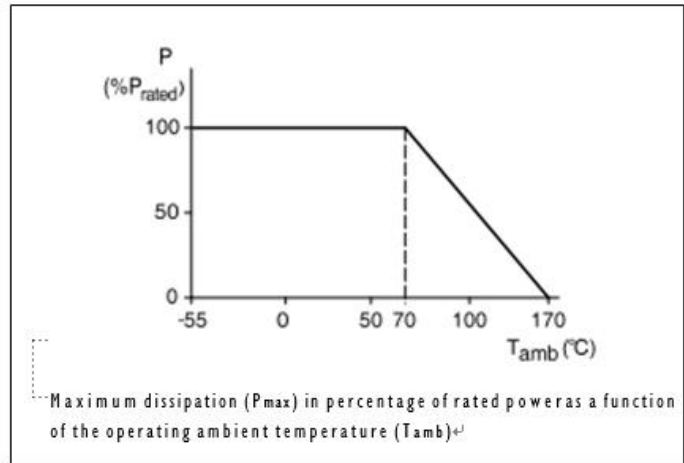

#### RATED VOLTAGE

The DC or AC (rms) continuous working voltage corresponding to the rated power is determined by the following formula:

$$V = (P \cdot R)^{1/2}$$

Where

V= Continuous rated DC or AC (rms) working voltage (V)

P = Rated power (W)

R = Resistance value ( $\Omega$ )

# 5. FOOTPRINT AND SOLDERING PROFILES

## FUNCTIONAL DESCRIPTION

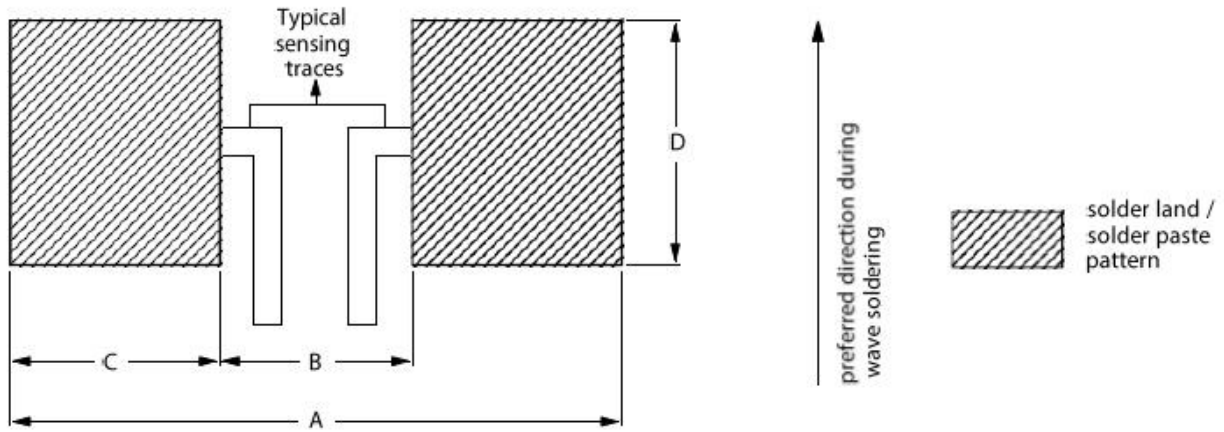

Single resistor chips recommended dimensions of footprints

TYPE	A	B	C	D
SD2512	7.5	1.3	3.1	4.0

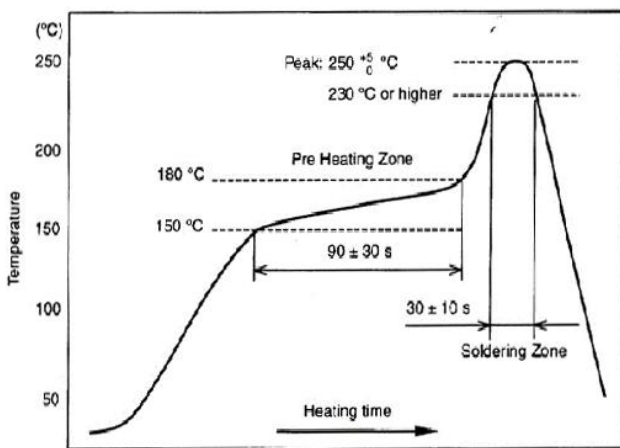

Peak value:  $250 \pm 5 / -0$  °C, 5 s,  
 Preheating zone: 150~180°C, 90±30 s,  
 Welding zone: 230°C or higher, 30±10 s

# 6. PACKING STYLE & PACKAGING QUANTITY

## PACKING STYLE AND PACKAGING QUANTITY

TYPE	PACKING STYLE	REEL DIMENSION	QUANTITY
SD2512	Embossed taping reel (K)	7"	4000

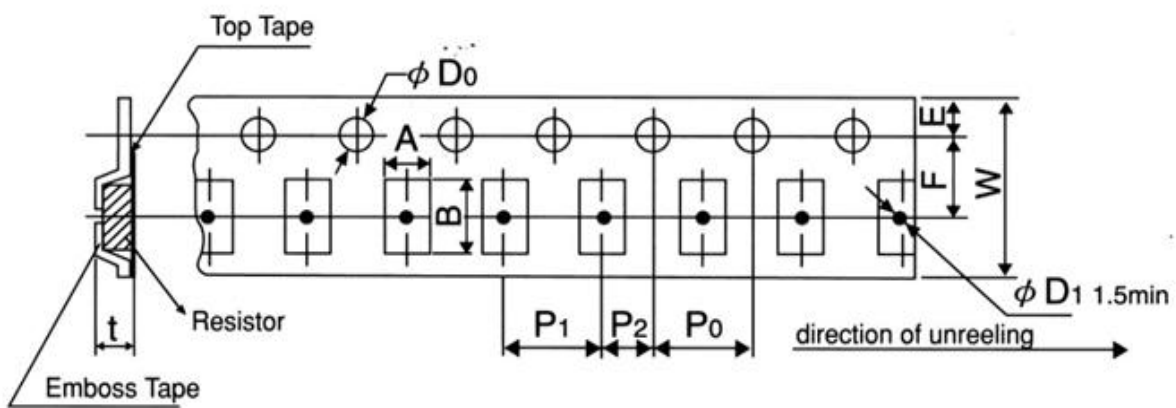

TYPE	A	B	W	F	E	P1	P2	P0	D0	t
SD2512	3.5±0.15	6.8±0.2	12.0±0.2	5.5±0.05	1.75±0.1	4.0±0.1	2.0±0.05	4.0±0.05	1.5+0.1/0	1.23±0.1

### PEEL-OFF FORCE

Peel-off forces of both paper/PE and embossed/blister tapes are in accordance with "IEC 60286-3" ; that is, at a peel-off speed of 300 ±10 mm/minute, 0.1 N to 1.0 N for 8 mm tape and 0.1 N to 1.3 N for tape larger than 8 mm. The peel-off angle should be between 165° and 180°.

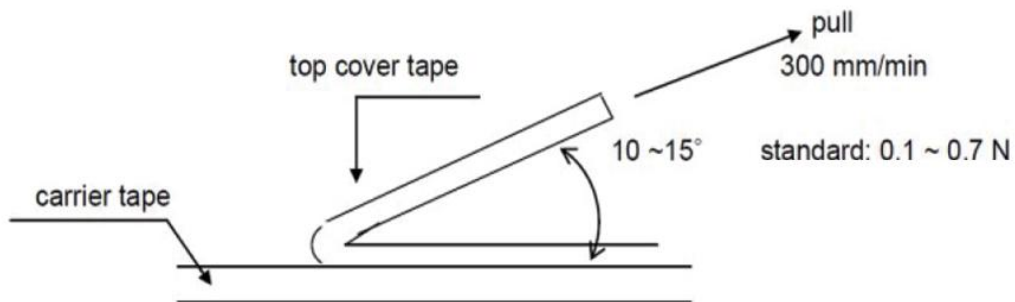



**REEL SPECIFICATION**

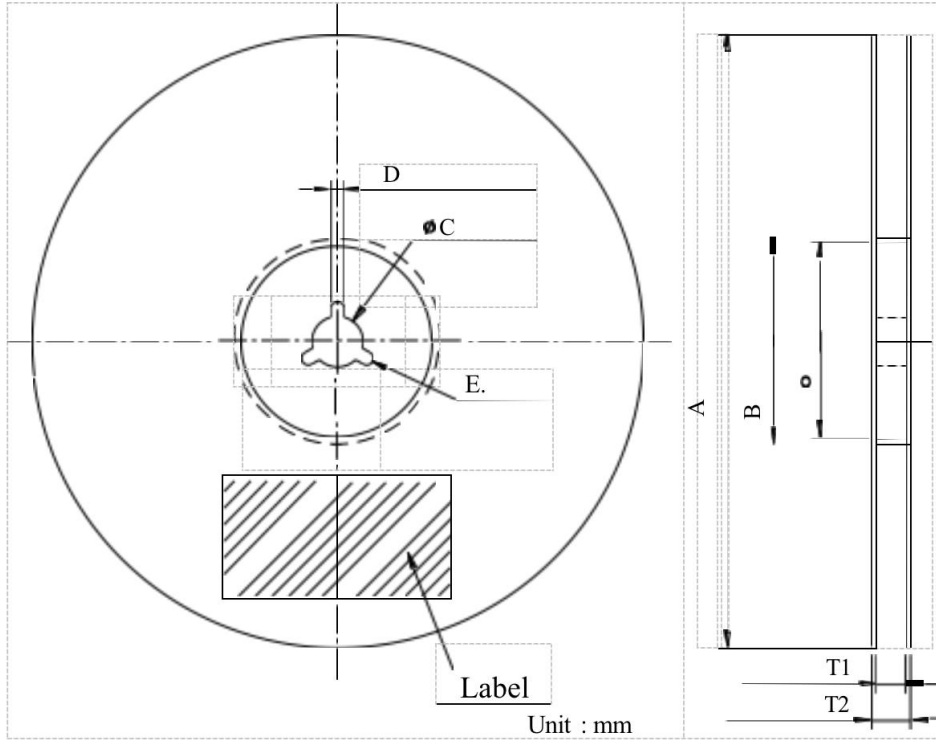

Unit: mm

TYPE	A	B	C	D	E	T1
SD2512	178±2.0	60±1.0	13±1.0	2.0±0.5	>22	13±0.3

# 7. TESTS AND REQUIREMENTS

## TESTS AND REQUIREMENTS

Project	Test Method	Specifications and Requirements
<b>Temperature coefficient (TCR)</b>	Resistance values were measured at 25 °C (T1, R1) and 125 °C (T2, R2), and TCR was calculated as $(R2-R1)/(R1 (T2-T1)) * 10^6$	Refer to TCR specifications for physical features
<b>Short Time Overload</b>	5 times rated power, maintain 5s	$\Delta R \leq \pm (1.0\%+0.05m\Omega)$
<b>Insulation resistance</b>	Apply 100V $\pm$ 15V DC voltage between electrode and substrate, hold for 60 seconds, then measure insulation resistance	> 100M $\Omega$
<b>Withstand voltage</b>	An alternating current with an effective value of the maximum overload voltage is applied between the electrode and the substrate at a rate of approximately 100V/S, maintaining 60 $\pm$ 5s	No breakdown or arc
<b>Solder ability</b>	245°C $\pm$ 5°C tin tank, hold 2s $\pm$ 0.5s	At least 95% of surface area of electrode shall be covered with new solder
<b>Resistance to Soldering Heat</b>	260°C $\pm$ 5°C tin tank, hold for 10s $\pm$ 1s	$\Delta R \leq \pm (0.5\%+0.05m\Omega)$ , no visible damage
<b>Bending test</b>	Bending distance 2mm, hold time 60s $\pm$ 5s	$\Delta R \leq \pm (1.0\%+0.05m\Omega)$ , no mechanical damage
<b>Solvent resistance</b>	Isopropanol (IPA) at 23°C $\pm$ 5°C for 10 hours	No obvious damage to appearance
<b>High Temperature Exposure</b>	150°C $\pm$ 2°C, 1000H, stand for 1H, test the resistance value	$\Delta R \leq \pm (1.0\%+0.05m\Omega)$
<b>Low Temperature Exposure</b>	-55°C $\pm$ 2°C, 1000H, stand for 1H, test the resistance value	$\Delta R \leq \pm (1.0\%+0.05m\Omega)$
<b>Rapid change of Temperature</b>	-55°C 30 minutes ~ normal temperature 5 minutes ~155°C 30 minutes, 1000 cycles	$\Delta R \leq \pm (1.0\%+0.05m\Omega)$
<b>Load Life</b>	70°C $\pm$ 2°C, 1000 hours, rated power, 1.5 hours on / 0.5 hours off	$\Delta R \leq \pm (1.0\%+0.05m\Omega)$
<b>Moisture with Load</b>	85°C $\pm$ 2°C, 85% $\pm$ 3%RH, 1000 hours, rated power, 1.5 hours on / 0.5 hours off	$\Delta R \leq \pm (1.0\%+0.05m\Omega)$

## 8. REVISION HISTORY

### REVISION HISTORY

REVISION	DATE	CHANGE NOTIFICATION	DESCRIPTIONN
Version 1	24-03-2022	-	-First issue of this specification

## 9. SUNWAY CONTACT

### Asia

#### **HQ Shenzhen China**

No. 1013, Xihuan Road, Shajing Town,  
Bao'an District, Shenzhen, China  
Tel: +86-755-81773388  
E-mail: Sales-south@sz-sunway.com

#### **Shanghai China**

Floor 1, Building 1, No. 2653 Hunan  
Road, Pudong New Area, Shanghai,  
China  
E-mail: Sales-east@sz-sunway.com

#### **Mianyang china**

No.268 Binhe North Road West Section,  
High-tech Zone, Mianyang, China

#### **Suwon South Korea**

101-801, Digital Empire 2, #88  
Sinwon-road, Yeongtong-gu, Suwon-Si,  
Gyeonggi-do, Korea

### Northern America

#### **Cupertino USA**

20040 Stevens Creek Blvd, Suite 100,  
Cupertino, CA 95014, USA

#### **Shenzhen China**

North third floor, block A, Tefa  
information port, No. 2 Kefeng Road,  
Science Park, Nanshan District,  
Shenzhen, China  
E-mail: Sales-south@sz-sunway.com

#### **Changzhou China**

No.369 Jinlong Road, Jintan District,  
Changzhou, China  
E-mail: Sales-east@sz-sunway.com

#### **Taiwan China**

Floor 2, NO 637 Ruiguang Road, Neihu  
District, Taipei City 114, Taiwan

#### **Vinh Phuc Vietnam**

CNO8-2, Binh Xuyen 2 IP, Ba Hien, Binh  
Xuyen, Vinh Phuc, Vietnam

#### **Beijing china**

No.14, Jinxiu Street, Business  
Development Area, Beijing, China  
E-mail: Sales-east@sz-sunway.com

#### **Yiyang China**

Yiyang High-tech Zone East Industrial  
Park Standardized Plant, Yiyang, China  
E-mail: Sales-east@sz-sunway.com

#### **Shin-Yokohama Japan**

3rd floor-A, INTELLEX-Shin-Yokohama  
building 1-17-12, Shin-yokohama,  
Kohoku-ku, Yokohama-shi, Kanagawa,  
Japan

### Europe

#### **Stockholm Sweden**

Kistagangen 20BS-164 40 Kista, Sweden  
Email: europe@sz-sunway.com

#### **Bettlach Switzerland**

Bischmattstrasse 7 CH-2544 Bettlach,  
Switzerland  
Email: europe@sz-sunway.com