



# MBRB2045CT thru MBRB2060CT

**20.0A Schottky Barrier Rectifiers**  
Rectifier Reverse Voltage 45 to 60V

## TO-263

### Features

- High frequency operation
- High purity, high temperature epoxy encapsulation for enhanced mechanical strength and moisture resistance
- Guard ring for enhanced ruggedness and long term reliability
- Solder dip 260 °C max. 8 s, per JESD 22-B106

### Mechanical Data

- **Package:** TO-220AB  
Molding compound meets UL 94 V-0 flammability rating, RoHS-compliant
- **Terminals:** Tin plated leads, solderable per J-STD-002 and JESD22-B102
- **Polarity:** As marked

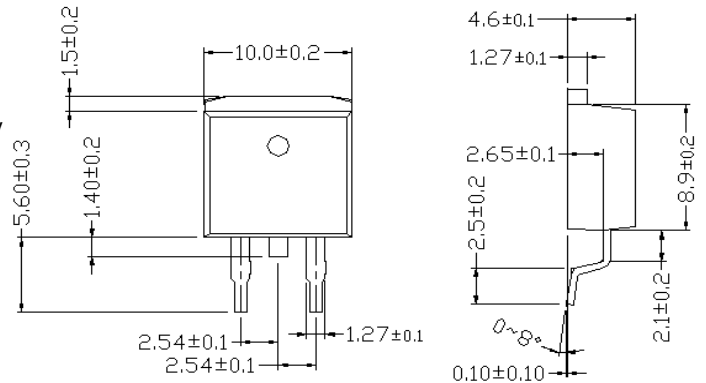

Dimensions in millimeters ( 1mm =0.0394" )

### ■Maximum Ratings (Ta=25°C Unless otherwise specified)

PARAMETER	SYMBOL	UNIT	MBRB2045CT	MBRB2060CT
Device marking code			MBRB2045CT	MBRB2060CT
Repetitive Peak Reverse Voltage	VRRM	V	45	60
Average Rectified Output Current @60Hz sine wave, R-load, Ta=25°C	IO	A	20	
Surge(Non-repetitive)Forward Current @60Hz half sine-wave, 1 cycle, Ta=25°C	IFSM	A	150	
Current Squared Time @1ms≤t<8.3ms Tj=25°C,	I <sup>2</sup> t	A <sup>2</sup> s	94	
Storage Temperature	Tstg	°C	-55 ~ +175	
Junction Temperature	Tj	°C	-55 ~ +150	

### ■Electrical Characteristics (Ta=25°C Unless otherwise specified)

PARAMETER	SYMBOL	UNIT	TEST CONDITIONS	MBRB2045CT	MBRB2060CT
Maximum instantaneous forward voltage drop per diode	VFM	V	IFM=10.0A	0.68	0.82
Maximum DC reverse current at rated DC blocking voltage per diode	I <sub>RRM1</sub>	mA	V <sub>RM</sub> =V <sub>VRRM</sub> Ta=25°C	0.25	0.2
	I <sub>RRM2</sub>		V <sub>RM</sub> =V <sub>VRRM</sub> Ta=125°C	20	
Thermal Resistance	R <sub>θJ-C</sub>	°C/W	Between junction and case	2.0	

# Rating and Characteristic Curves ( $T_A=25^{\circ}\text{C}$ Unless otherwise noted )

## MBRB2045CT thru MBRB2060CT

FIG1:  $I_o$  -  $T_c$  Curve

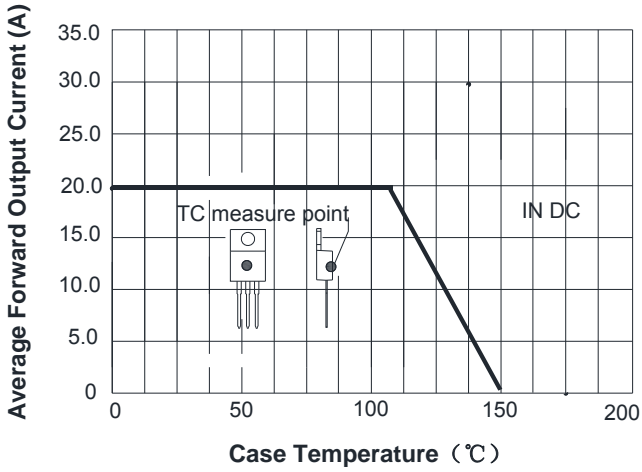

FIG2: Surge Forward Current Capability

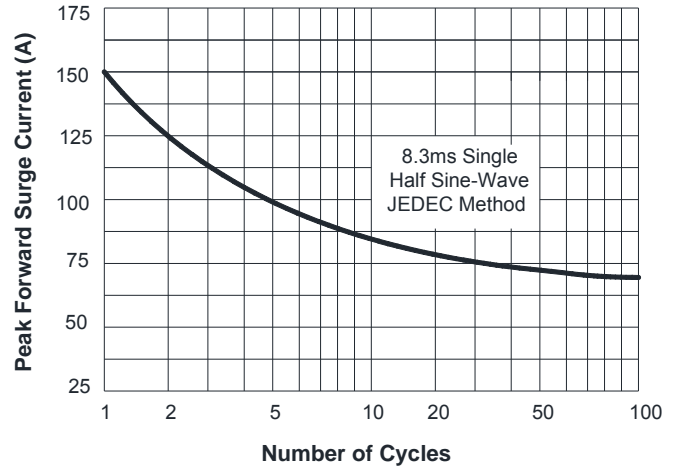

FIG3: Forward Voltage

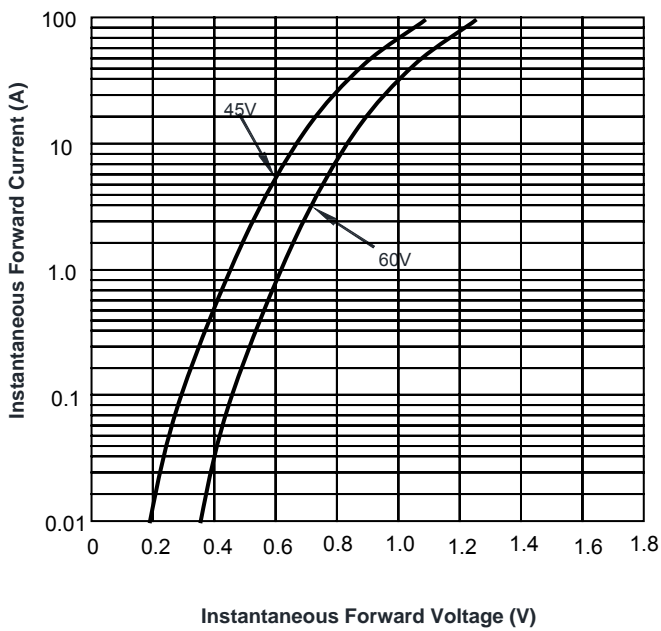

FIG4: Instantaneous Reverse Characteristics

