

AEC-Q200 (–40 to 85°C) qualified component family

## Multilayer Antenna

For 2400-2484MHz

# ANT162442ST-1000AM1

---

**1.6x0.8mm [EIA 0603]\***

\* Dimensions Code JIS[EIA]

---

## Multilayer Antenna

Conformity to RoHS Directive

For 2400-2484MHz

## ANT162442ST-1000AM1

## SHAPES AND DIMENSIONS

[Top view]

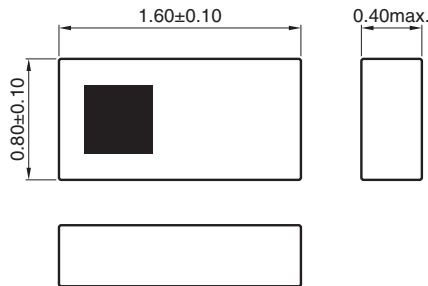

[Bottom view]

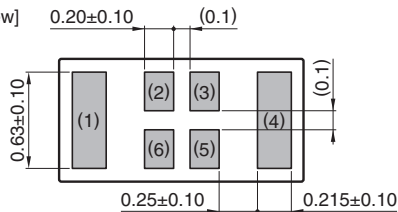

Terminal functions

1	Radiator electrode
2	Dummy pad
3	Dummy pad
4	Feed point
5	Dummy pad
6	Dummy pad

Dimensions in mm

## RECOMMENDED LAND PATTERN

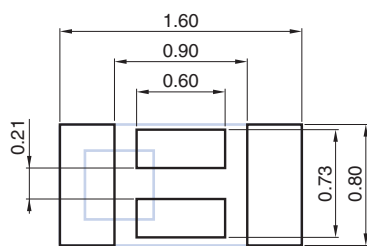

Dimensions in mm

## SOLDER RESIST PATTERN

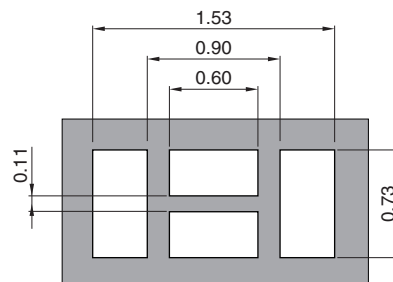

Dimensions in mm

○ RoHS Directive Compliant Product: See the following for more details. <https://product.tdk.com/info/en/environment/rohs/index.html>

- All specifications are subject to change without notice.
- Before using these products, be sure to request the delivery specifications.

# ANT162442ST-1000AM1

## EVALUATION BOARD

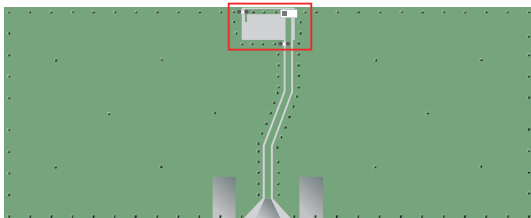

PCB size : 50mm x 20mm x 1mm  
Antenna area : 5 x 3 mm

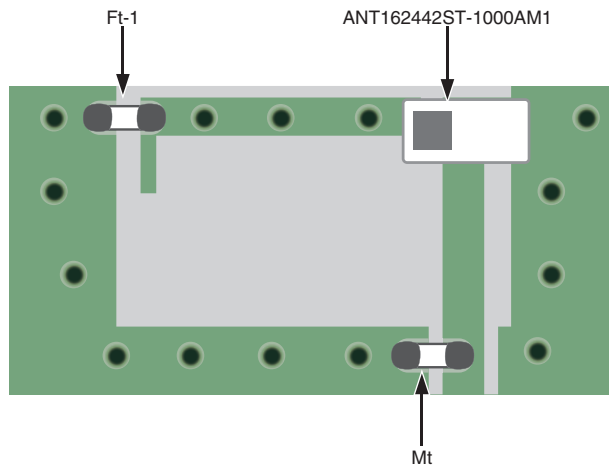

	Component P/N
Ft-1	6.2pF
Mt	0.8pF

### Measurement condition for Radiation Pattern

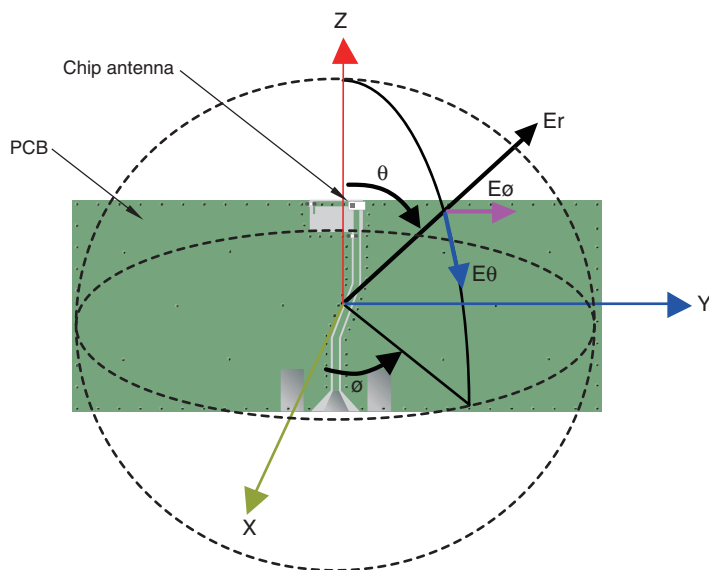

- All specifications are subject to change without notice.
- Before using these products, be sure to request the delivery specifications.

# ANT162442ST-1000AM1

## ELECTRICAL CHARACTERISTICS

Item	Frequency Range (MHz)	Min.	Typ.	Max.
VSWR	2400 to 2484	—	1.60	3.0
Polarization			Linear	
PCB size (mm)			50×20	
Antenna keep-out area (mm)			5×3	
Characteristic Impedance ( $\Omega$ )			50 (Nominal)	

• This is typical antenna performance with the standard PCB.

## TEMPERATURE RANGE

Operating temperature (°C)	Storage temperature (°C)
-40 to +85	-40 to +85

## FREQUENCY CHARACTERISTICS

### EFFICIENCY AND VSWR

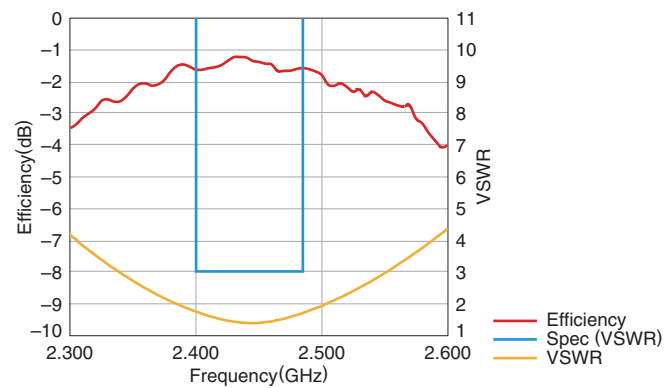

• Tested antenna has been soldered. Evaluation board size is 50x20x1 mm.

# ANT162442ST-1000AM1

## RADIATION PATTERNS

### 2.4GHz BAND

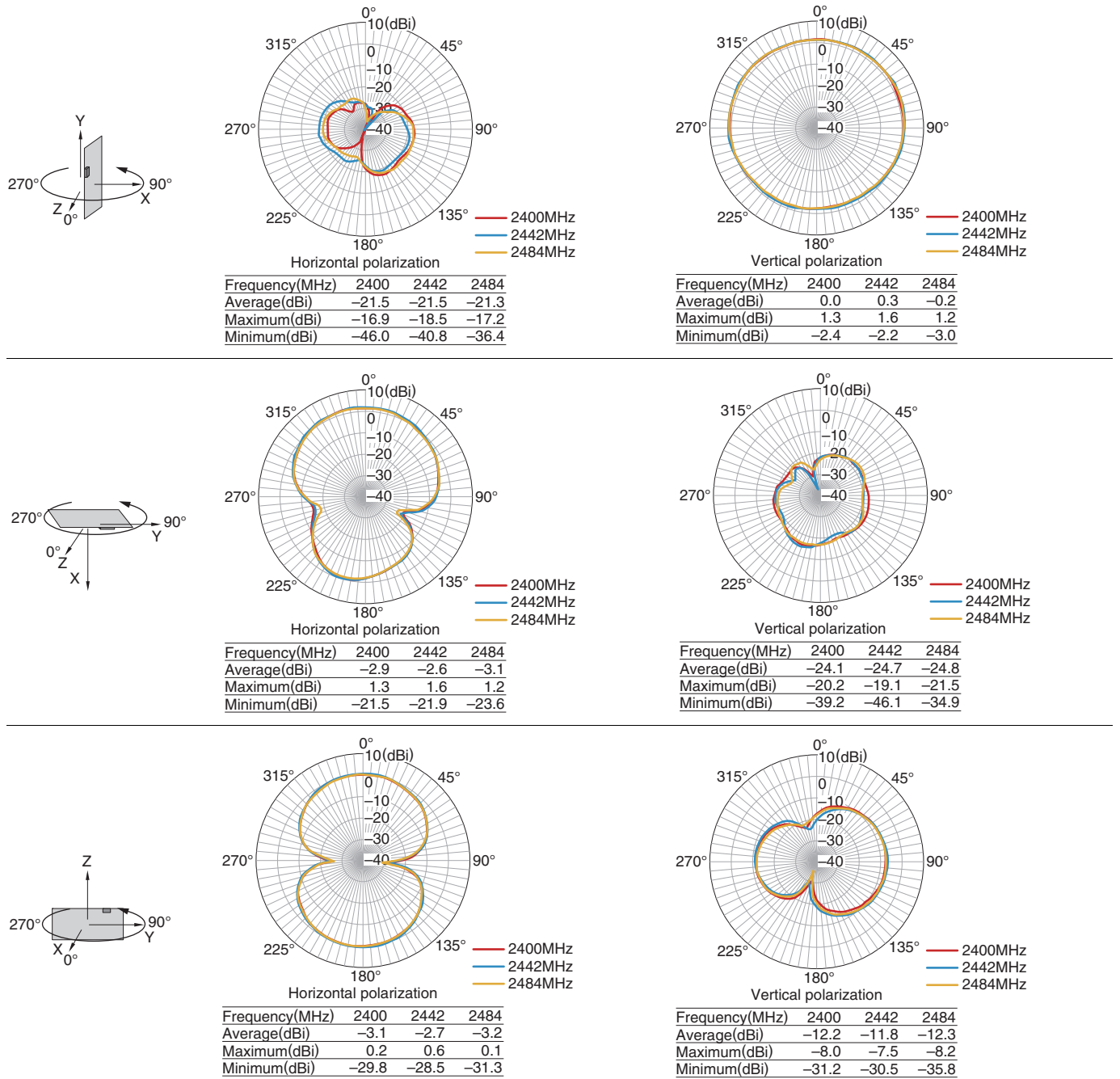

• Tested antenna has been soldered. Evaluation board size is 50x20x1 mm.

- All specifications are subject to change without notice.
- Before using these products, be sure to request the delivery specifications.

**RECOMMENDED REFLOW PROFILE**

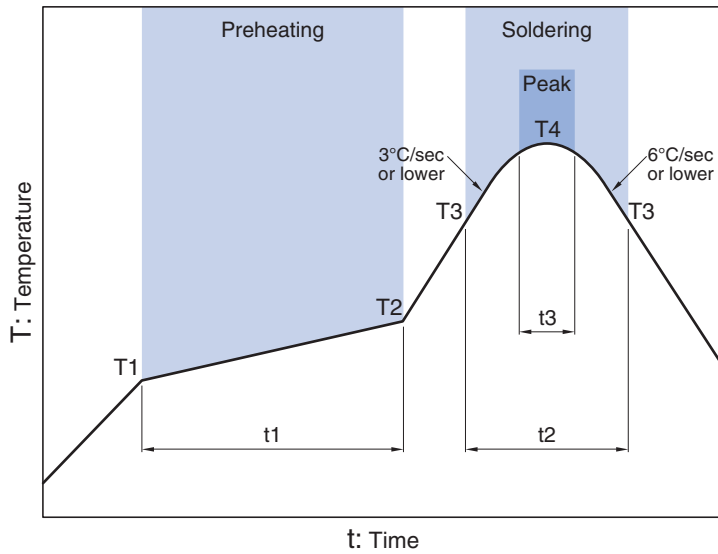

Preheating			Soldering			
Temp.	Time		Critical zone (T3 to T4)		Peak	
T1	T2	t1	T3	t2	T4	t3*
150°C	200°C	60 to 120sec	217°C	60 to 120sec	240 to 260°C	30sec max.

\* t3 : Time within 5°C of actual peak temperature  
 The maximum number of reflow is 3.

# ANT162442ST-1000AM1

## PACKAGING STYLE

### REEL DIMENSIONS

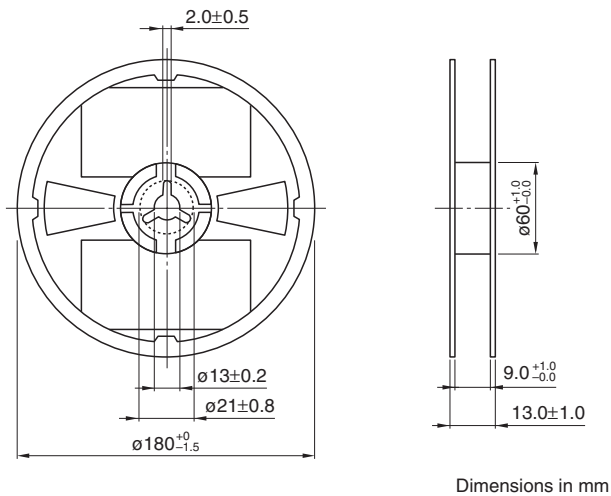

### TAPE DIMENSIONS

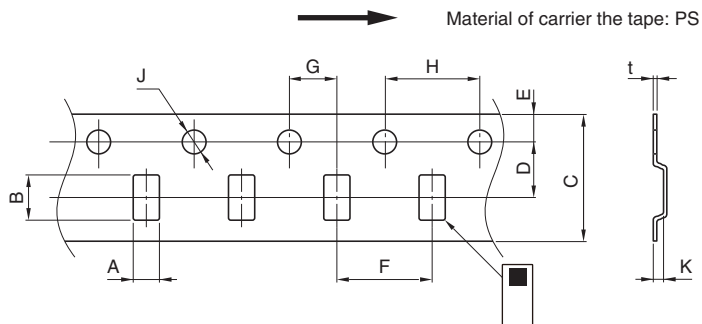

Dimensions in mm

A	B	C	D	E	F	G	H	J	K	t
0.97±0.05	1.8±0.05	8.0±0.2	3.5±0.05	1.75±0.1	4.0±0.1	2.0±0.05	4.0±0.1	1.5+0.1/-0	0.55max.	0.25±0.05

## PACKAGE QUANTITY

Standard package quantity  
(pieces/reel)

4,000

- All specifications are subject to change without notice.
- Before using these products, be sure to request the delivery specifications.

## 使用注意事项

在使用本产品前，请务必随附采购规格书。

## 安全注意事项

使用本产品时，请注意安全事项。

### 注意

本产品目录中记载的产品是指在通用标准用途意义上使用于一般电子设备（AV 设备，通信设备，家电产品，娱乐设备，计算机设备，个人设备，办公设备，计测设备，工业机器人），并且该一般电子设备要在通常的操作和使用方法下使用。

对于需要高度安全性和可靠性的，或者设备的故障，误动作，运转不良可能会给人的生命，身体及财产等造成损害，以及有可能产生莫大社会影响的以下用途（以下称‘特定用途’）中的适用性，性能发挥，品质，本公司不予保证。

产品被在本产品目录的范围、条件之外，或者在特定用途中使用，本公司对它造成的损害和信赖性不承担任何责任。

- |                         |                    |
|-------------------------|--------------------|
| (1) 航天航空设备              | (8) 公共信息处理设备       |
| (2) 交通运输设备（汽车，电动火车，船舶等） | (9) 军事设备           |
| (3) 医疗设备                | (10) 电加热设备、燃烧设备    |
| (4) 发电控制设备              | (11) 防灾 / 预防犯罪设备   |
| (5) 原子能源相关设备            | (12) 安全设备          |
| (6) 海底设备                | (13) 其他不被视为常规用途的用途 |
| (7) 交通控制设备              |                    |

为了能够更安全地使用产品，对使用本产品目录中所记载产品的设备进行设计时，请确保符合该设备的使用用途及状态的保护回路和装置，并设置备用回路等。