

Date of application
Nov. 21. 2017

NICHICON CORPORATION
NICHICON (OHNO) CORPORATION
DESIGN DEPT.

S P E C I F I C A T I O N
O F
ALUMINUM ELECTROLYTIC CAPACITORS

UHE1C222MPDEZX

DWG. No.	H171121h6	CHECKED	M.Murayama Nov. 21. 2017
DESIGNED.	K.Kominami Nov. 21. 2017	APPROVED	J.Kobayashi Nov. 21. 2017

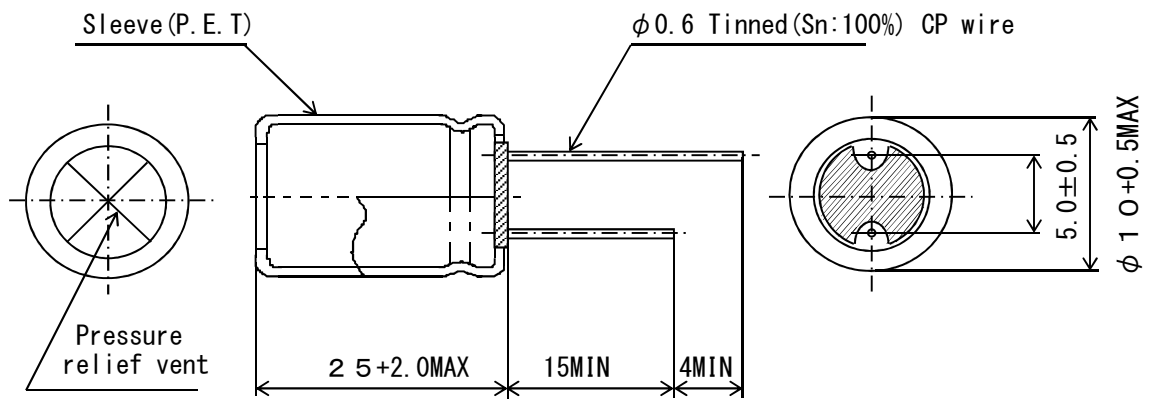

<Example>

nichicon
 2200 μ F 16V

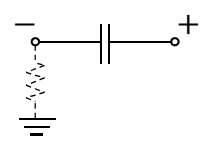
 HE (M)
 105°C
 Lot. No.



CONNECTION DIAGRAM

Sleeve color: Black
 Marking color: White

IMPEDANCE: 0.022 Ω MAX. at 20°C 100kHz
 0.066 Ω MAX. at -10°C 100kHz

ELECTRICAL CHARACTERISTICS

WORKING VOLTAGE (V. D. C)	SURGE VOLTAGE (V. D. C)	RATED CAP (μ F)	CAP. TOL. (%)	$\tan \delta$ (MAX)	LEAKAGE CURRENT (μ A MAX)	RIPPLE CURRENT (mArms MAX)
16	20	2200	± 20	0.18	352	2200
at 120Hz 20 °C					16 V at 100kHz 20°C after 2min	at 100kHz 105°C

TEST STANDARD

JIS C 5101-4

OPERATING TEMP. RANGE

-40 ~ 105°C

				NICHICON TYPE NO.			
				UHE1C222MPDEZX			
				RATE			
				16V		2200 μ F	
				3RD ANGLE PROJEC- TION	SCALE /mm	DATE	CASE SIZE
MARK	DATE	DESCRIPTIONS	APPR.			2017/11/21	$\phi 10 \times 25 L$
REVISION :							
SPECIFICATION				DWG. No.		H171121h6	
						sheet	2

SPECIFICATION ALUMINUM ELECTROLYTIC CAPACITOR

1. SCOPE
This specification covers polarized aluminum foil drytype electrolytic capacitors.
(JIS-04 TYPE)
2. APPLICABLE SPECIFICATION
Japanese Industrial Standard JIS C 5101-4:1998 Characteristics W and
JIS C-5101-1:1998 except as specified in this specification.
3. PERFORMANCE
Unless otherwise specified, the standard range of atmospheric conditions
for making measurements and tests is as follows :
 Ambient temperature : 5 to 35°C
 Relative humidity : 45 to 85%RH
 Air pressure : 86kPa to 106kPa
 If there may be any doubt on the results, measurements shall be made within the
 following limits,
 Ambient temperature : 20±2°C
 Relative humidity : 60 to 70%RH
 Air pressure : 86kPa to 106kPa

No.	Item	Test method	Performance
3.1	OPERATING TEMPERATURE RANGE		-40 ~ 105 °C
3.2	RATED VOLTAGE		16 V
3.3	CAPACITANCE	at 120Hz±20%	2200 μF±20%
3.4	tan δ	at 120Hz±20% To comply with JIS C 5101-1 4.8	0.18 MAX.
3.5	LEAKAGE CURRENT	To comply with JIS C 5101-1 4.9 After 2 minute's application of rated voltage.(at 20°C)	352 μA MAX.
3.6	SURGE VOLTAGE	To comply with JIS C 5101-1 4.26 The surge voltage specified in the individual standard shall be applied 1000 times, each for 30±5s, period of 6±0.5min. Electric discharge : Not to carry Out Test temperature : 15~35°C	Capacitance : Not less than 80 % of the value before test. tan δ : Not more than 200 % of the specified value. Leakage current : Initial specified value or less
3.7	IMPEDANCE RATIO AT LOW TEMPERATURE	To comply with JIS C 5101-1 4.10 -25,-40 ℃ 2h Measurement frequency : 120Hz±20%	Z _{-25°C} / Z _{20°C} ≤ 2 Z _{-40°C} / Z _{20°C} ≤ 4
3.8	TERMINAL STRENGTH	To comply with JIS C 5101-1 4.13 Tensile strength of termination : tensile force holding time tensile force : 10 N Bending strength of termination : Count it as 2 times. Dead weight : 5 N	No abnormality such as cutting off, looseness or the like of termination.
3.9	SOLDERABILITY	To comply with JIS C 5101-1 4.15 Temperature of solder : 235±5°C Dipping time : 2±0.5 s Storage time : after 6 month	At least 3/4 of circumferential surface of the dipped prtion of termination shall be covered with new solder.
3.10	RESISTANCE OF SOLDERING	To comply with JIS C 5101-1 4.14 Temp. : 260±5°C Time : 10±1s or Temp. : 350 ±10°C Time : 3 ℃ s	Capacitance change : Within ±10% of initial value tan δ : Initial specified value or less. Leakage current : Initial specified value or less. Appearance : No remarkable abnormality.

No.	Item	Test method	Performance
3.11	RESISTANCE TO DAMP HEAT (STEADY STATE)	To comply with JIS C 5101-1 4.22 Test temperature : 40±2°C Relative humidity : 90~95%RH Test time : 240±8h	Capacitance change : Within ±15% of initial value tan δ : Initial specified value or less. Leakage current : Initial specified value or less. Appearance : No remarkable abnormality.
3.12	ENDURANCE	To comply with JIS C 5101-1 4.23 Test temperature : 105±2°C Test time : 7000 ⁴⁷² / ₃ h D.C. bias with rated ripple current so that its peak voltage shall not exceed the rated D.C. voltage.	Capacitance change : Within ±25 % of initial value tan δ : 200 % or less of initial specified value. Leakage current : Initial specified value or less. Appearance : No remarkable abnormality.
3.13	RESISTANCE TO VIBRATION	To comply with JIS C 5101-1 4.17 Direction and duration of vibration : 3 orthogonal directions mutually directions mutually each for 2h Total 6 h Frequency : 10 to 55 Hz Reciprocation for 1 min. Total amplitude : 1.5 mm	Capacitance : When the capacitance is measured, there shall be no intermittent contacts, or open or short-circuiting, and no abnormality. Appearance : No remarkable abnormality.
3.14	PRESSURE RELIEF VENT TEST	A.C. Application Test The capacitor shall be subjected to an A.C. voltage (50 to 60Hz) with r.m.s value equal to 0.7 times the rated D.C. voltage through a series resistor. The series resistor as follows. $R = 0.1 \Omega$ D.C. Application Test The capacitor shall be subjected to a reverse D.C. voltage equal to the rated D.C. voltage. the current flowing through the capacitor shall be limited to 1A.	There is no fire, when pressure relief vent operated. And also there is no explosion or fire etc at the testing for 30 minutes.
		NOTE : The test is terminated, if pressure relief vent does not operate for 30 minutes.	

4. MARKING

Capacitors shall be legibly marked with following.

- 4-1 Manufacture's Trade mark
- 4-2 Rated voltage
- 4-3 Nominal capacitance
- 4-4 EIA DATE CODE
- 4-5 Negative polarity
- 4-6 Capacitance Tolerance
- 4-7 Maximum operating temperature identification
- 4-8 Series identification

5. OTHERS

- The Relevant Export Regulation Laws:
In case that there is a certain danger of the products conflicting with the use and activity for the developments of weapons of mass destruction, the procedures based upon the relevant export regulation laws are absolutely needed.

- Ozone Depletion Substance
Ozone depletion substances are not used in our production process and at our suppliers.

- Brominated Flame Retardants
The restricted brominated flame retardants are not used.

- Estimated life
Please use the estimated life, which is calculated at various temperature conditions etc, as reference value.

- Production factory
NICHICON (OHNO) CORPORATION
NICHICON (IWATE) CORPORATION
NICHICON (MALAYSIA) SDN. BHD.
NICHICON ELECTRONICS (WUXI) CO., LTD.