

Features

- SMD construction, and low profile.
- High Impedance and Excellent Frequency Characteristic.
- Self Electromagnetic Shielding.
- Low Magnetic Flux Leakage.

Applications

- LED Light, TV game, Monitor, etc.
- EMI common-mode noise.

Product Identification

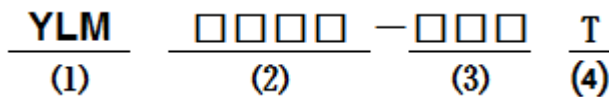

- (1) : Type
- (2) : Dimensions
- (3) : Impedance
- (4) : Taping

Shapes and Dimensions (Unit: mm)

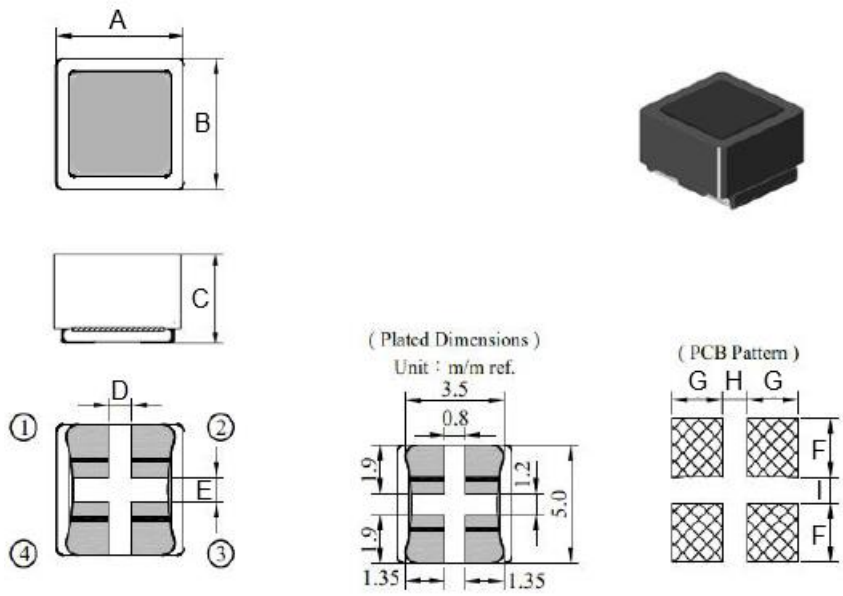

TYPE	A	B	C Max.	D Typ.	E Typ.	F Ref.	G Ref.	H Ref.	I Ref.
YLM5025	4.8±0.2	5.0±0.2	2.5	0.8	1.0	2.3	1.6	0.8	1.0

■ Circuit Diagram

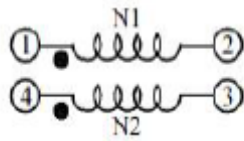

■ YLM5025 Series

Part Number	Common mode Impedance (Ω)	Test Frequency	Rated Voltage (Vdc) Max.	DCR ($m\Omega$) Max.	Rated Current (A) Max.	IR ($m\Omega$) Min.
YLM5025-101T	100(Typ)	100MHz/0.5V	50	13	6.0	10
YLM5025-251T	250(Typ)	100MHz/0.5V	50	20	5.0	10
YLM5025-501T	500(Typ)	100MHz/0.5V	50	27	4.0	10
YLM5025-102T	1000(Typ)	100MHz/0.5V	50	34	2.0	10
YLM5025-142T	1400(Typ)	100MHz/0.5V	50	56	1.5	10
YLM5025-152T	1500(Typ)	100MHz/0.5V	50	56	1.5	10

1. Rated Current: Temp.rise 40°C Typ
2. Operating Temperature: -40°C up to +125°C
- 3.Storage Temperature: -20°C up to +40°C,75% RH Max.

■ Material List

NO.	ITEM	DESCRIPTION	SUPPLIER
1	CORE	FERRITE	FENGYIN OR EQ
2	WIRE	P180 Grd1	ELEKTRISOLA OR EQ
3	ADHESIVE	EPOXY RESIN	NAGASE OR EQ
4	SOLDER	Sn99.3:Cu0.7	SHENMAO OR EQ

Reliability Testing

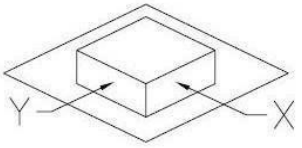
Operating Temperature	- 40 to + 125 °C (Contain Heating coil)
Appearance Inspection	No external defects by visual inspection
Terminal Strength 	After soldering , between copper plaet and terminals of coils , push in two directions of X , Y with standing 10N(1.02kg) for10+/-2 sec. Terminal should not peel off. (Refer to figure at right)
Heat endurance of reflow soldering	Refer to figure
Insulating resistance	Over 100 MΩ at 100V D.C . between wire and core .
Dielectric Strength	Apply at 0.5KV 3mA for 1 minute between wire and core .
Temperature characteristics	Inductance coefficient (0~2,000) × 10 / °C (- 20 ~ + 125 °C)
Humidity characteristics	Inductance deviation within ± 10% , after 96 hours in 90~95% relative humidity at 40 ± 2 °C and 1 hours drying under normal condition .

A test is made under the above mentioned condition , and it is kept for 2 hours in the normal

Recommended soldering temp.Graph

IR Reflow profile

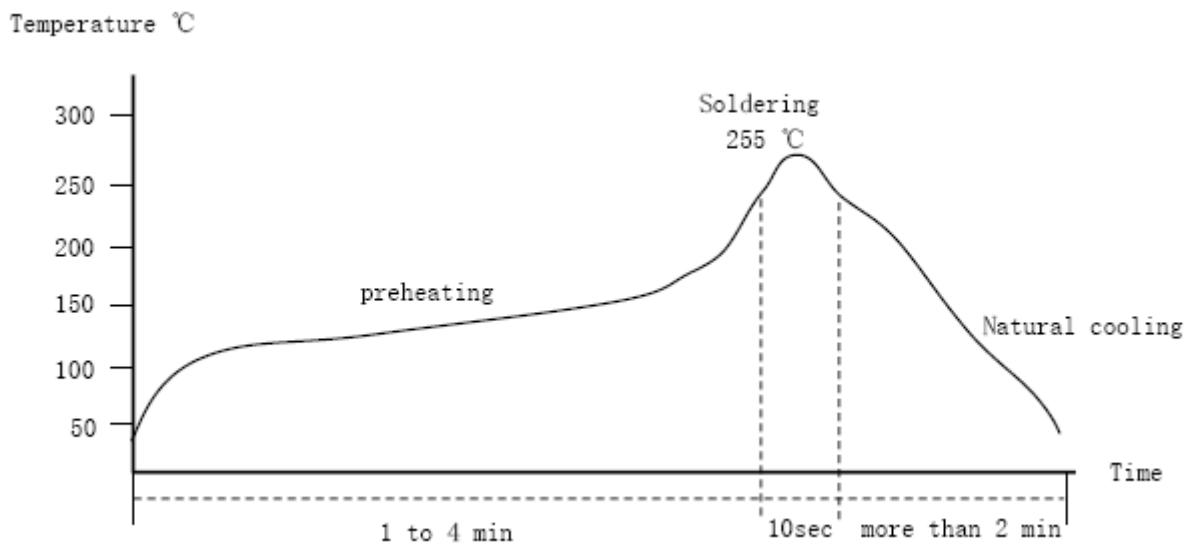

Temperature and humidity. After that,no mechanical and electrical defect should be found.

■ Taping Dimensions(Unit:mm)

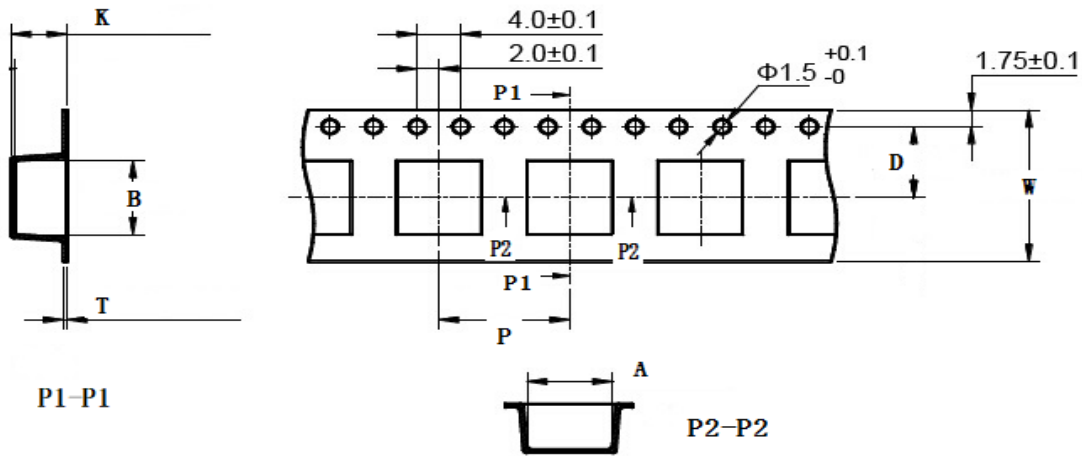

TYPE	W	A	B	D	P	K	T	MPQ
YLM5025	16.0±0.3	6.4±0.3	6.4±0.1	7.5±0.1	8.0±0.1	5.0±0.1	0.40±0.05	2500

■ Reel Dimensions(Unit:mm)



TYPE	W	W1	A	B	C	D
YLM5025	330±2.0	24.4±1.5	30.4MAX	23.9 Min	13.0±0.50	21.0±0.80

Direction of rolling

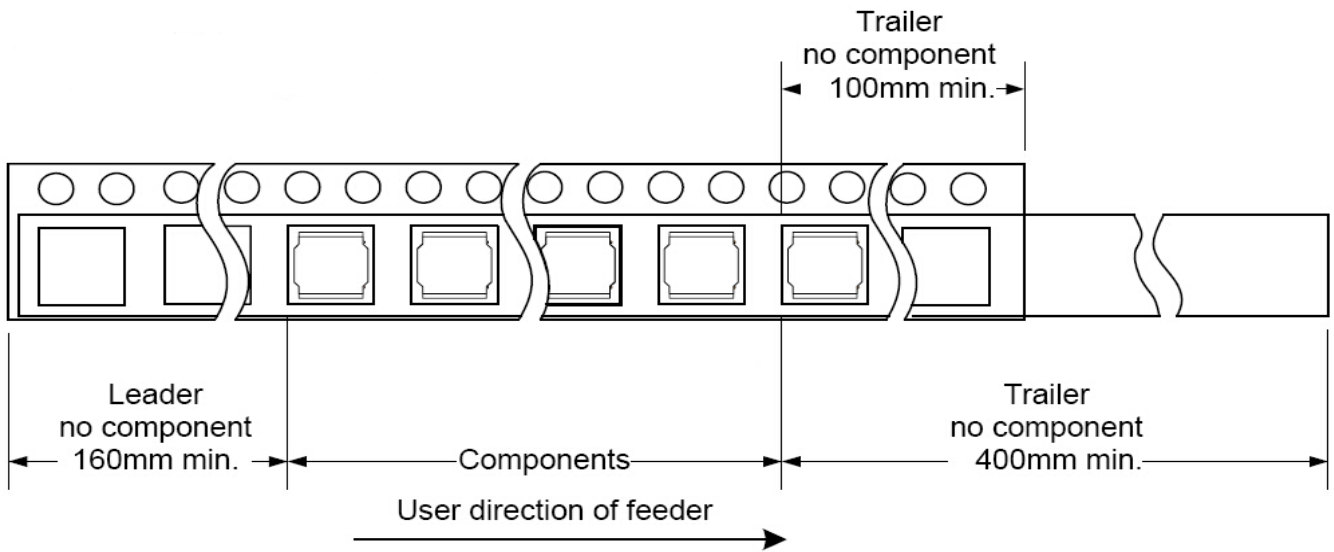

Cover tape peel off condition

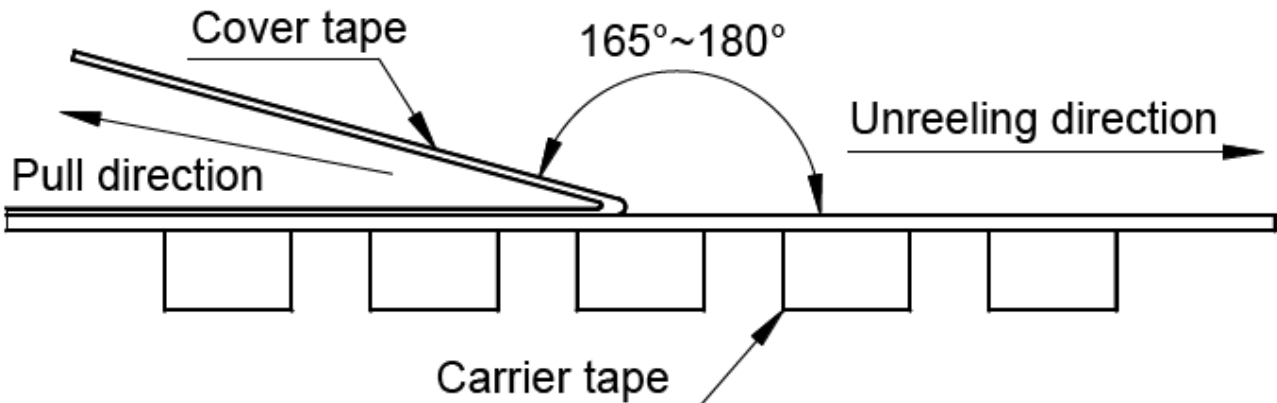

Cover tape peel force shall be 0.1N to 1.3N.

Reference peel speed 300±10mm/min.