

ROHS compliant

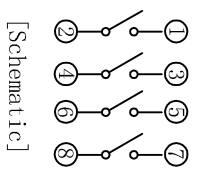
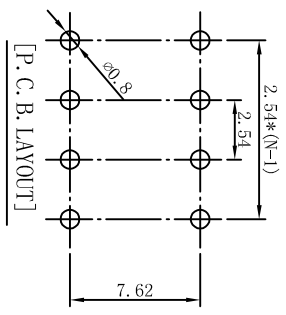
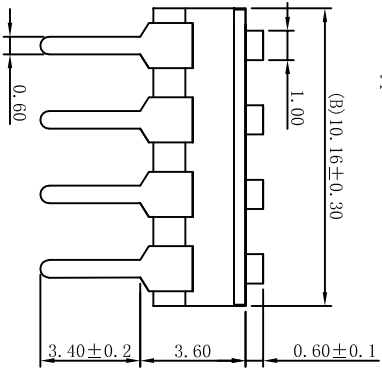
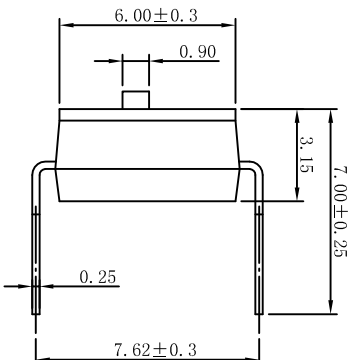
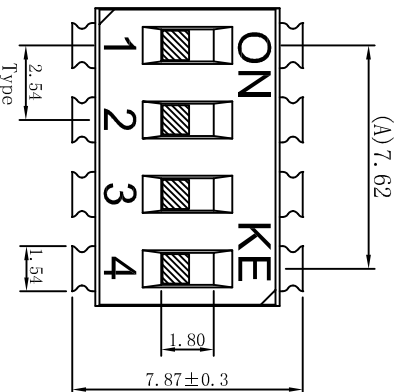

REV.	ECN NO.	DRAWN	DATE

**NOTES:**

**1.Specification:**

- 1>. Operation force: 1000gf Max.
- 2>. Operation Temperature: -30 °C to +85°C.
- 3>. Storage Temperature: -40 °C to +85°C.
- 4>. Mechanical Life: 3000 cycles operations.
- 5>. Resistance to Soldering: 260 ±5°C for 3-5 Seconds.

**2.PLATING:**

- 1>. GOLD Flash 1u" (min) SOLDERTAIL, 3u" GOLD PLATING ON THE CONTACT AREA.

**3.ELECTRICAL:**

- 1>. Non-switch Rating: 100mA at 50V DC.
- 2>. Switching Rating: 25mA at 24V DC.
- 3>. Contact Resistance: Initial 50mΩ Max. Contact Resistance: After life 100mΩ Max.
- 4>. Insulation Resistance: 1000MΩ Min at 50VDC.
- 5>. Dielectric Strength: 500V AC for 60seconds.
- 6>. Switch Capacitance: 5PF Max at 1MHZ.

**4.PART NUMBER DESCRIPTION:**

DSIC XX T S G E T

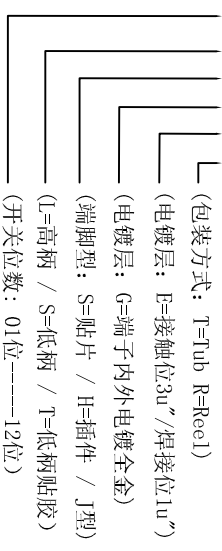

**5.PACKING: 50pcs/Tube, 2500pcs/Box.**

Drawing	dengkg	Date	2018.03.24	LINER	ANGLES	PRODUCT Family	DSIC Series	Pitch	2.54mm
Check	zhong	Scale	4:1	>0±0.05	>0° ±0.5°	PRAT NO.	DSIC04LHGT		
Approved		Unit	MM	>1±0.10	>5° ±1.0°	FILE NO.	KE-DSIC-004-H-A		
Size	A4	Rev.	A	>10±0.30		PROJECTION			

东莞市康深电子科技有限公司  
 Kongshe Electronics technology co., LTD.