

承 认 书
SPECIFICATION FOR APPROVAL

客户名称 Customer: _____

贵司料号CUSTOMER P/N: _____

敝司料号INTERIOR P/N: AA07A09010000002A

贵公司承认印 Approval signatures

料 号/Part No.	签 章/Signatures

Send us a copy of reference, thank you!

日期 Date: _____

地址: 浙江省乐清市虹桥镇信岙工业区
 Add: Xinao Industry Zone Hongqiao Yueqing
 Zhejiang
 电话/Tel: 86-0577-57573366
 传真/Fax: 86-0577-57573373
 Http://www.cnbozhong.com
 Alibaba: Http://dezhimei.cn.alibaba.com

拟制/Drawn	朱光隆
审核/Check	陈乐峰
批准/Approved	陈乐峰

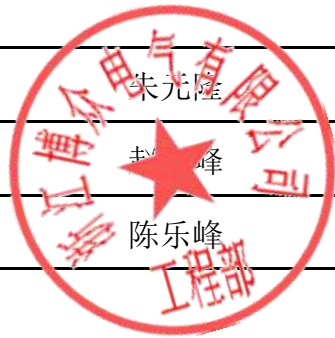

AA07A0901000002A

5(2)A 125/250VC T105μ
5E4

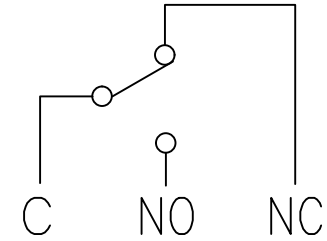
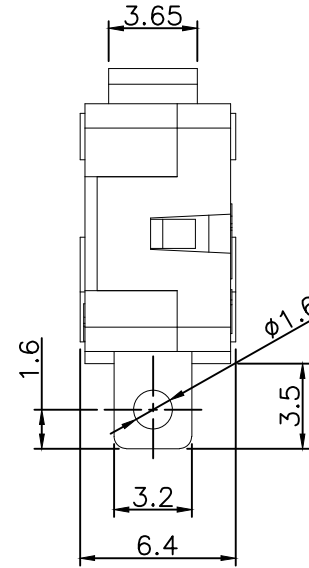
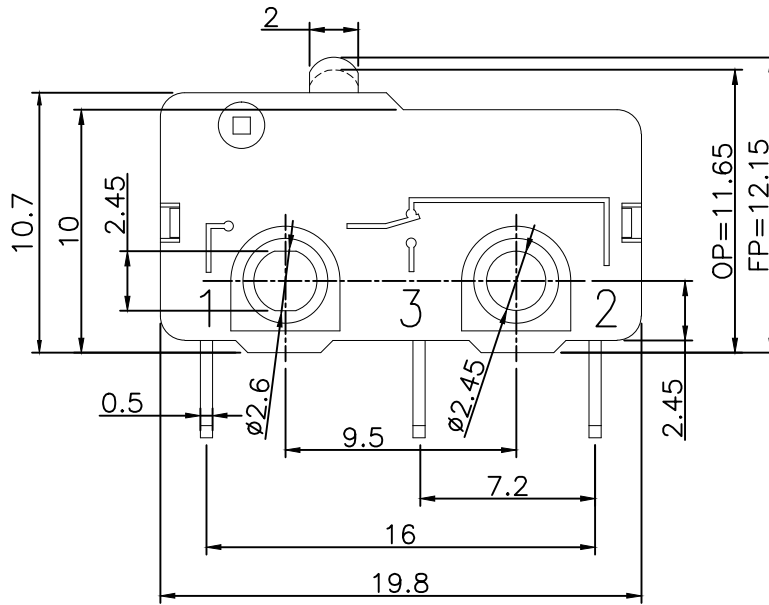

电路图
CIRCUIT DIAGRAM

主要技术参数、性能

The Main Thchnology Performance

额定电流、电压 Rate voltage,current	5A 125/250VAC
接触电阻 Contact resistance	≤100mΩ
按力 Operating force	150±50gf
绝缘电阻 Insulated resistance	≥100MΩ
介电强度 Dielectric strength	≥1000VAC/5s

					第一视角 FIRST VIEW	名称/NAME: 微动开关 MICRO SWITCH	
						型号/MODEL: MSB-中微动银点	
标记 SING	处数 FREQUENCY	更改文件号 REVISION	签名 APPROVED	日期 DATE	比例 SCALE	1:1	一般公差 GENERAL TOLERANCE
设计 DESIGN			2022.07.01		单位 UNIT	mm	≥0~5< ±0.30
审核 CHECKED			2022.07.01		重量 WEIGHT		≥5~30< ±0.40
批准 APPROVED			2022.07.01				≥30 ±0.50
							角度 ANGLE
							±2°
						BZCN 浙江博众电气有限公司 ZHEJIANG BOZHONG ELECTRONIC CO.,LTD.	