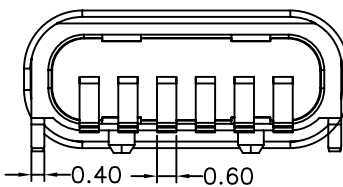
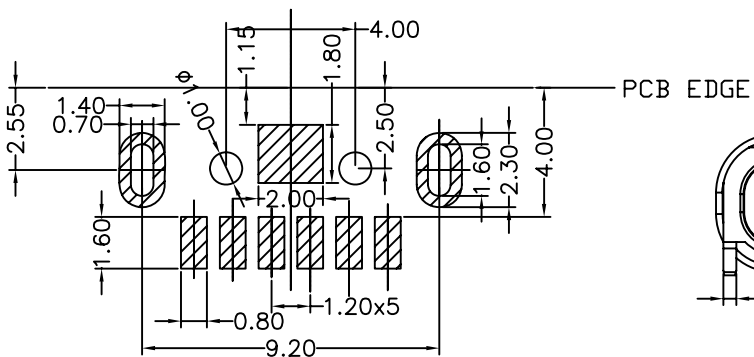
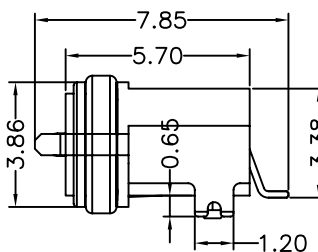
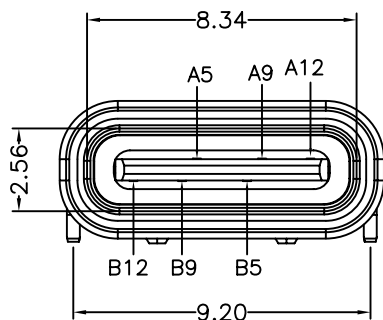

TABLE B

A5	CC1	B12	GND
A9	VBUS	B9	VBUS
A12	GND	B1	GND
PIN	SIGNAL NAME	PIN	SIGNAL NAME



PCB LAYOUT 图仅供参考

Note:

1. Material:
 - 1.1 Housing: PA9T
 - 1.2 Contact: C5191, t=0.20mm
 - 1.3 Shell: Kirsite
2. ELECTRICAL:
 - 2-1: CURRENT RATING:
 - VBUS AND GND CONTACTS RATED AT 1.25A PARALLELED FOR A TOTAL OF 5A;
 - 2-2: INITIAL CONTACT RESISTANCE :40 MEGOHMS
 - 2-3: DIELECTRIC WITHSTANDING VOLTAGE:
 - 100V AC MIN;
- 3: MECHANICAL CHARACTERISTICS:
 - 3-1: MATING FORCE: 5~20N
 - 3-2: UNMATING FORCE: 8~20N(INITIAL),
 - 6~20N(AFTER 10000 CYCLES)
 - 3-3: FREQUENCY: 200±50 CYCLES /HOUR, 10000 CYCLES
 - 3-4: OPERATING TEMPERATURE ; -40°~80°.
- 4: WATERPROOF: IP-X7.



深圳市华宇创精密电子有限公司

TOLERANCE: X.X ±0.30 X.XX ±0.25 X.XXX ±0.15 X: ±2' X.X' ±0.5'	DRAWN BY : 陈一鸣	DATE : 2014-02-23	PART NAME: 防水USB TYPE C 6P 外壳DIP 端子SMT
	CHECKED BY: 马跃	DATE : 2014-02-23	PART NO. HYCW246-USBC06-570B
UNIT: mm [inch] SCALE:1:1 SIZE: A4	APPROVED BY: 邱敏	DATE : 2014-02-23	DRAW NO: HYC-USB2103092006
			SHEET NO. 1 OF 1