

(21) GOLD AND PALLADIUM PLATING MUST EXTEND A MINIMUM OF 5.5 MM FROM TIP OF TERMINAL

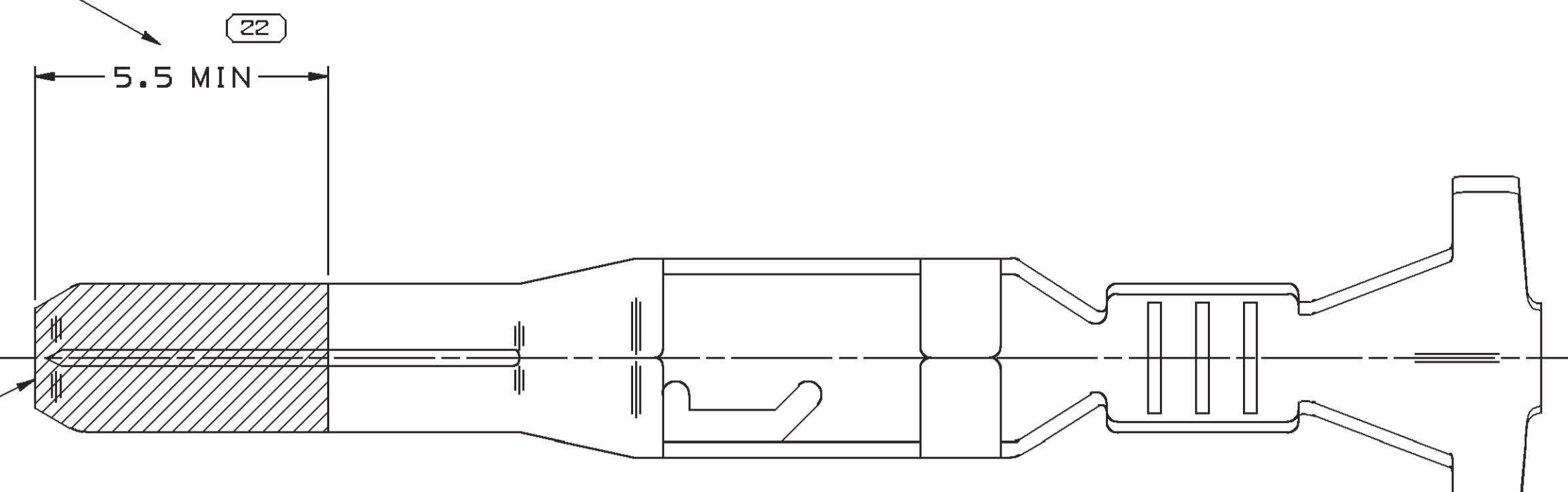

(20) GOLD AND PALLADIUM PLATING MUST EXTEND TO THE TIP OF THE TERMINAL. NO EXPOSED NICKEL OR BASE METAL PERMITTED ON TIP OF TERMINAL.

TYPE 102
SAME AS TYPE 101
EXCEPT AS SHOWN

SYMBOL DEFINITION		TOTAL NO OF INSPECTIONS REQUIRED	MISSING SYMBOLS
A DIMENSION WITHOUT AN INSPECTION REPORT SYMBOL DOES NOT REQUIRE INSPECTION. IT MAY BE CONTROLLED ON THE INDIVIDUAL COMPONENT DRAWING.		22	NO MISSING SYMBOL NUMBER
		LAST NO. USED	22

DWS STATUS		ZONE		REVISION HISTORY		AUTH	DR	APVD	APVD
DATE	STG	REV	N/P	CHG					
30JL02	R	04	-	-	CLEARED REV COLUMN: ALL PARTS - UPDATED PDM ATTRIBUTES	226419	ECB	JAA	TTP
040C04	R	05	-	-	ALL PARTS - ADDED STAMP DIE I.D.	259308	JPB	JVM	MKM
22SE08	R	06	-	-	13722257 & 13722260 - RELEASED	406107	JOA	FKV	EJB
160C08	R	07	-	-	13737694 - RELEASED 13722257 & 13722260 - MAT'L SPEC WAS M6030MNB C42500 EX HD	406450	EAJ	FKV	EJB
270C08	R	08	-	-	15304730-32 & 15336262 - UPDATED MATERIAL CALLOUT	406618	VMR	HAD	VMR
26FE09	R	09	-	-	13737694 - MOVED TO DRAWING 15304721 SHT 1	407452	JTZ	FKV	BER
18MR10	R	10	-	-	ALL PARTS - UPDATED PDM ATTRIBUTES	410172	ESC	ESC	MAC
13JL10	R	11	-	-	13828750 - RELEASED	411349	VMR	VMR	VMR
04AU10	R	12	-	-	13839334 & 13839335 - RELEASED	411517	ACR	JVM	VMR
27AU10	R	13	-	-	ALL PARTS - UPDATED MAT'L DESC; ADDED "CONTACT TYPE" COLUMN, "CRIMP TYPE" COLUMN & "PLATING TYPE" NOTE	411799	HRS	HRS	VMR
060C10	R	14	-	-	ALL PARTS - UPDATED "PLATING TYPE" NOTE	412130	JRL	JRL	VMR
06MR12	R	15	-	-	ALL PARTS - ADDED PREFERRED MAT'L SIZE AND UPDATED MATERIAL CALLOUT	417314	CBG	CBG	OAF
150C14	R	16	-	-	13722257 & 13722260 - REVISED NOTE 1111 ABOUT "TARNISH INFO" IN PLATING TYPE NOTE AND 13839334 & 13839335 - OBSOLETE	427926	ABH	JVM	JSM

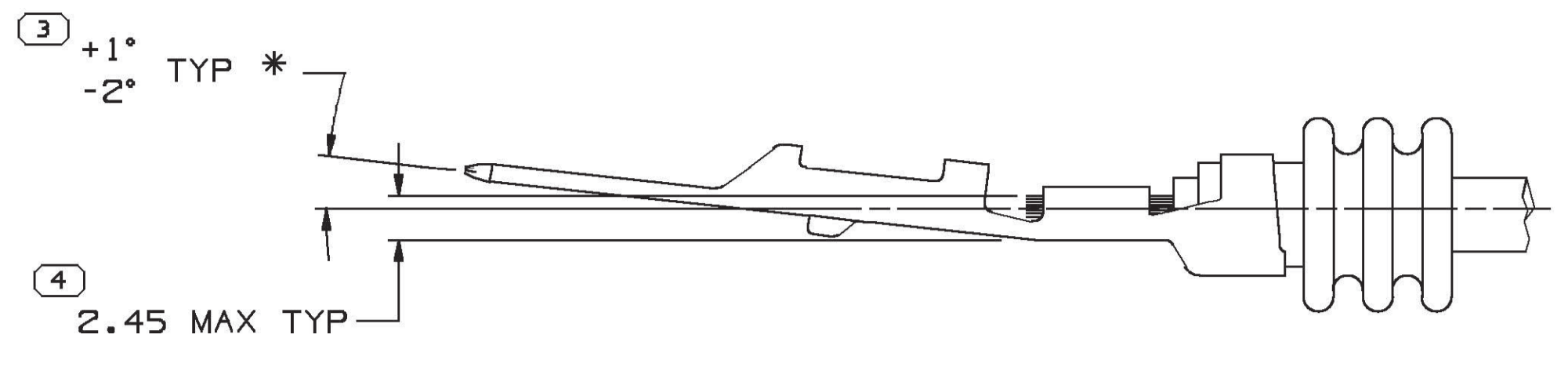

TERMINAL, SEAL AND CABLE ALIGNMENT
SCALE 5:1

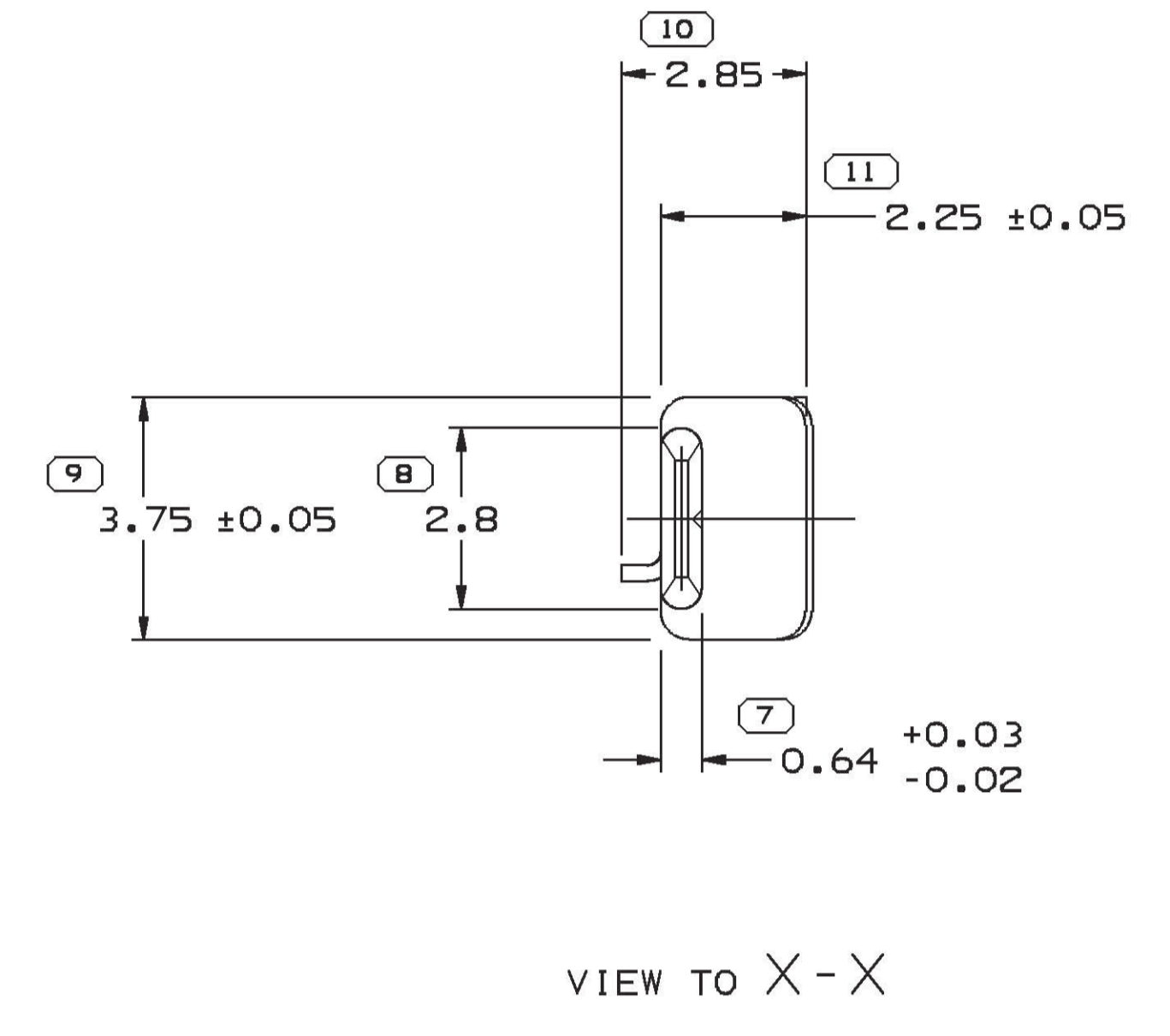

VIEW TO X-X

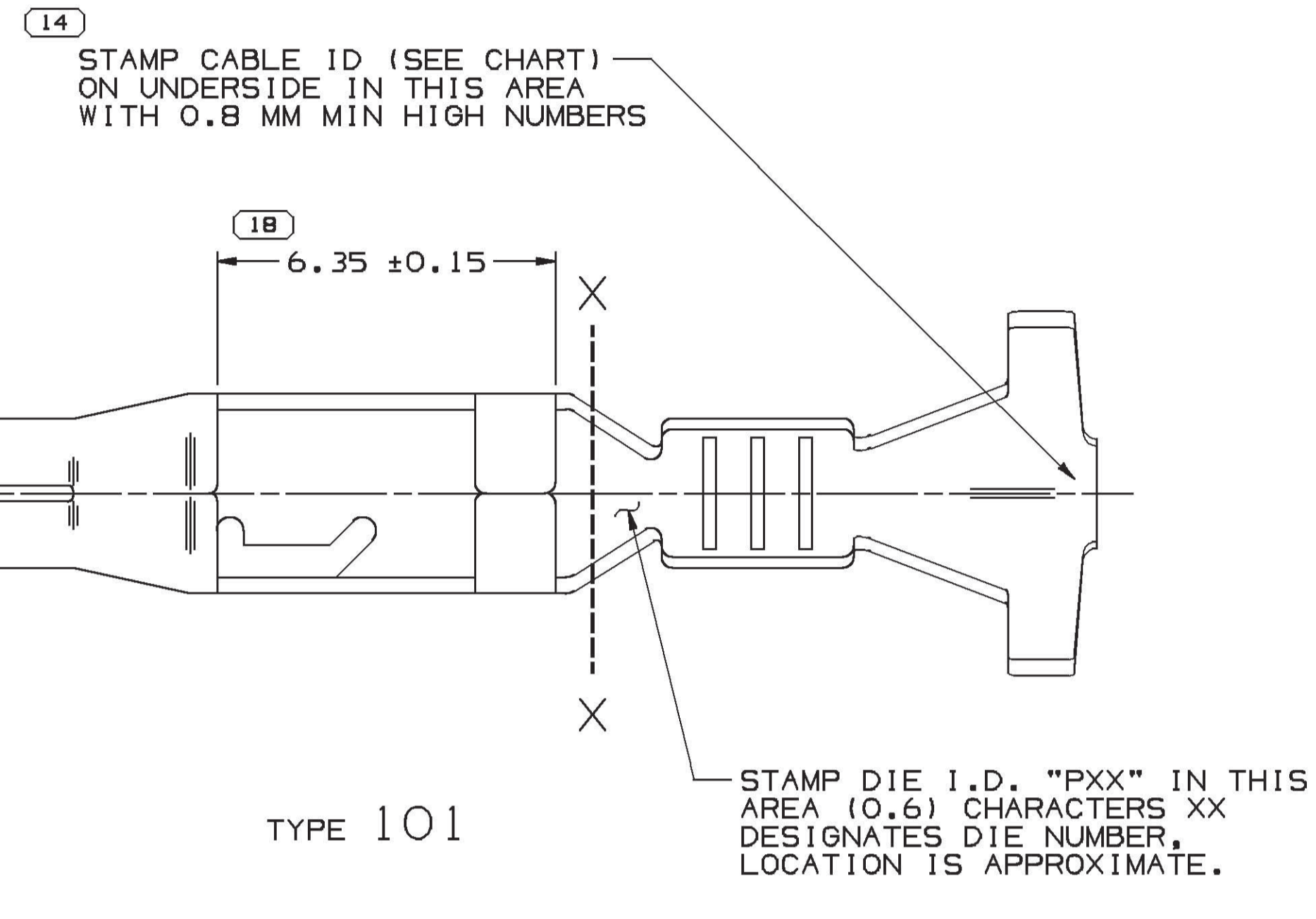

TYPE 101

STAMP DIE I.D. "PXX" IN THIS AREA (0.6) CHARACTERS XX DESIGNATES DIE NUMBER, LOCATION IS APPROXIMATE.

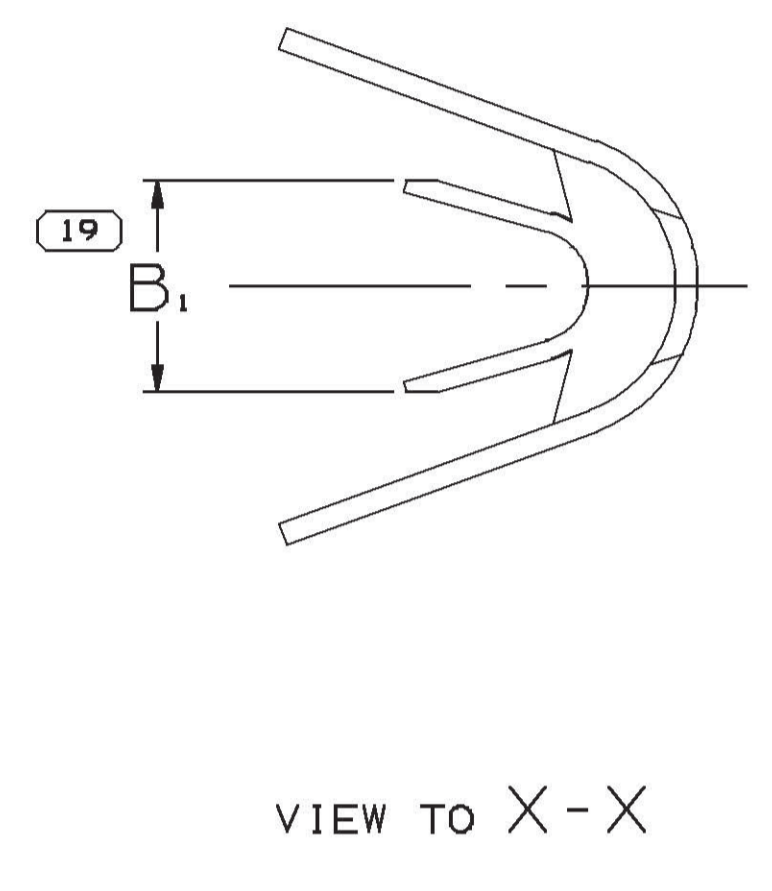

VIEW TO X-X

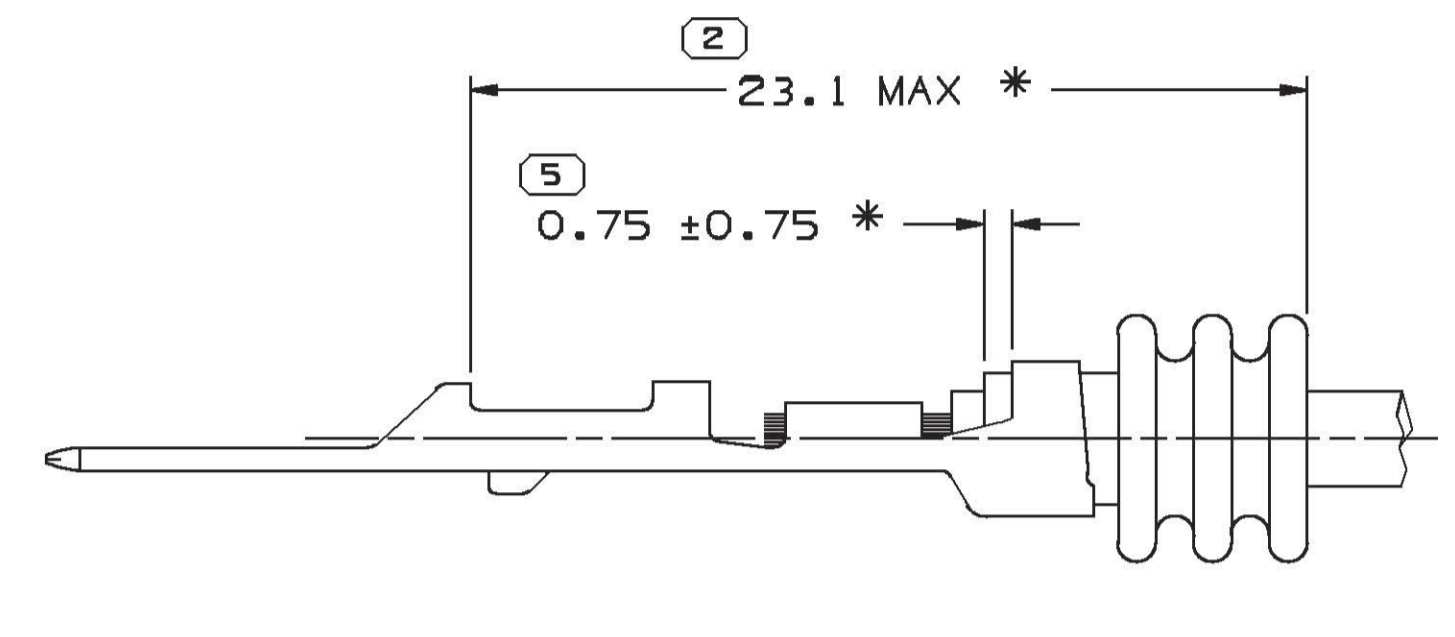

THREE RIB SEAL POSITION REF
SCALE 5:1

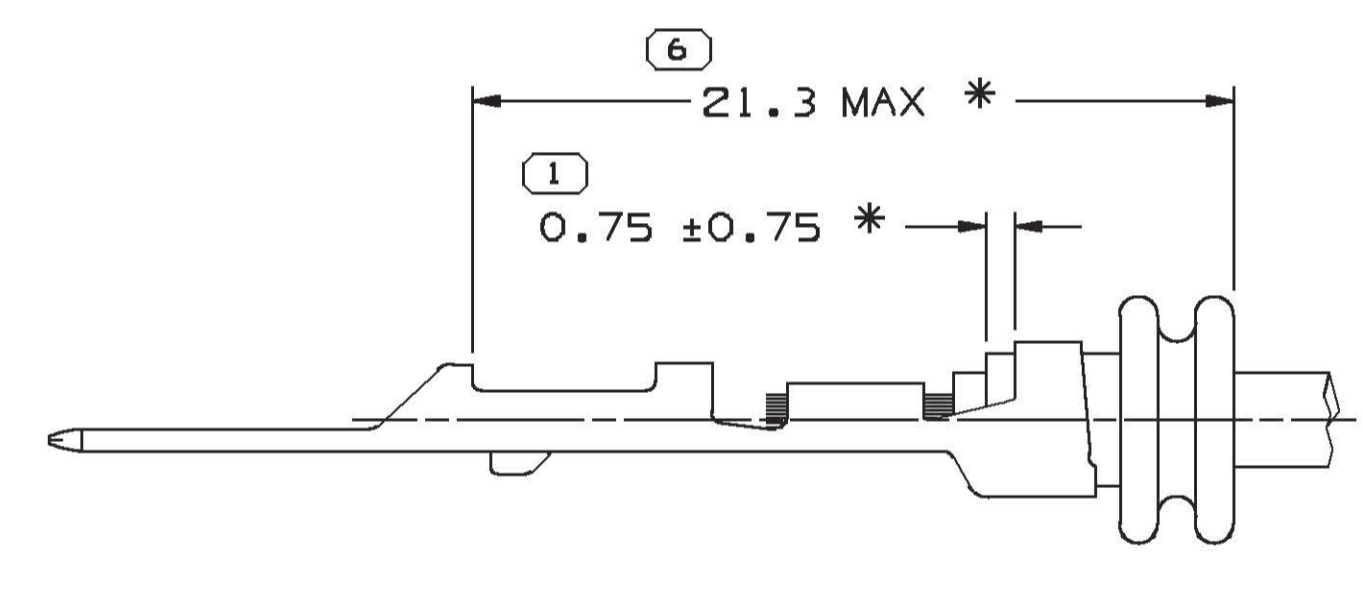

TWO RIB SEAL POSITION REF
SCALE 5:1

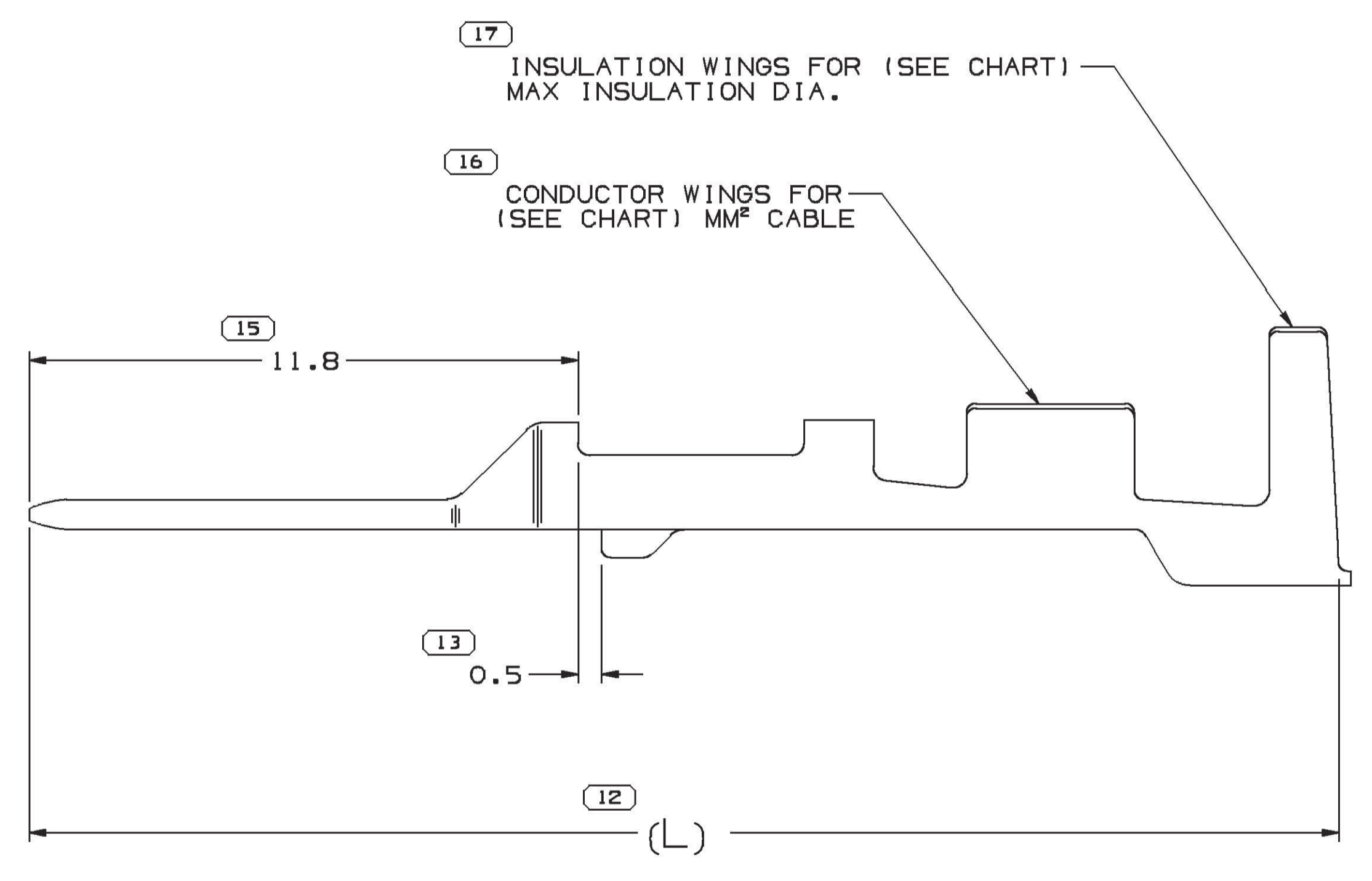

(17) INSULATION WINGS FOR (SEE CHART) MAX INSULATION DIA.
(16) CONDUCTOR WINGS FOR (SEE CHART) MMF CABLE

NOTES

- UNLESS OTHERWISE SPECIFIED AND/OR INDICATED:
DIMENSIONS ARE TO FACE OF VIEW SHOWN AND AUTOMATICALLY ROUNDED BY COMPUTER FOR INSPECTION (SEE MATH MODEL FOR PRECISE DIMENSIONS). FOR ALL OTHER DIMENSIONS NOT SHOWN BUT REQUIRED FOR TOOL BUILD, SEE MATH MODEL FOR PRECISE TOOL PATH DATA.
- REFERENCE MATING COMPONENTS OR EQUIVALENT:
TERMINAL 15304718
- * DENOTES DIMENSIONS MADE AT CUT-OFF AND CRIMP DIE.
- PLATING TYPE:
 - REFLOW TIN 1.9 - 3.3 MICROMETERS THICK WITH A COPPER UNDERPLATE 0.5 MICROMETER TO 1.0 MICROMETER THICK.
 - MATE TIN ELECTROPLATE 1.9 - 7.0 MICROMETERS THICK WITH A NICKEL UNDERPLATE 0.13 - 0.25 MICROMETERS THICK.
 - SILVER 3.5 - 6.0 MICROMETERS THICK OVER 0.13 - 0.25 MICROMETERS THICK NICKEL UNDERPLATE.

○ FOR TERMINALS PACKAGED & STORED IN THE APPROVED MANNER, TARNISH ON SILVER PLATED SURFACES WILL NOT AFFECT THE PERFORMANCE OF THE PART.

 - GOLD FLASH 0.1 MICROMETERS THICK OVER 1.0 MICROMETER PALLADIUM AND NICKEL UNDERPLATE 0.37 - 0.62 MICROMETERS THICK.
 - MATE TIN ELECTROPLATE 1.9 - 7.0 MICROMETERS THICK.

PLATING TYPE INFORMATION SHOWN ABOVE IS REFERENCE ONLY. PLATING REQUIREMENTS ARE CONTAINED IN APPLICABLE MATERIAL SPECIFICATION.

PART NO	REV	N/P	STATUS	PREFERRED MAT'L SIZE	ALTERNATIVE MAT'L SIZE	MATERIAL DESCRIPTION	SIZE (MM)	ID	DIA	TYPE	B _{1±0.2}	(L)	CONTACT AREA PLATING TYPE (SEE NOTE 4)	CRIMP AREA PLATING TYPE (SEE NOTE 4)
13839335	01	AD	-	0.3 X 35.75	0.3 X 36.12	AU PLATED COPPER ALLOY	0.75 - 1	17	2.25 - 1.7	102	2.65	28.15	IV	V
13839334	01	AD	-	0.3 X 35.75	0.3 X 36.12	AU PLATED COPPER ALLOY	0.35 - 0.5	21	1.85 - 1.2	102	2.1	28.15	IV	V
13828750	01	AC	-	0.3 X 35.75	0.3 X 36.12	AU PLATED COPPER ALLOY	1.5 - 3	13	3.2 - 2.2	102	3.75	28.15	IV	V
13722260	01	AF	-	0.3 X 35.75	0.3 X 35.75	A0 PLATED COPPER ALLOY	0.75 - 1	17	2.25 - 1.7	101	2.65	28.15	III	II
13722257	01	AF	-	0.3 X 35.75	0.3 X 35.75	A0 PLATED COPPER ALLOY	1.5 - 3	13	3.2 - 2.2	101	3.75	28.15	III	II
15336262	B7	-	-	0.3 X 35.75	0.3 X 36.12	COPPER ALLOY	1.25 - 2.5	14	3 - 2.05	101	3.7	28.15	I	I
15304732	EB	-	-	0.3 X 35.75	0.3 X 36.12	COPPER ALLOY	1.5 - 3	13	3.2 - 2.2	101	3.75	28.15	I	I
15304731	EB	-	-	0.3 X 35.75	0.3 X 36.12	COPPER ALLOY	0.75 - 1	17	2.25 - 1.7	101	2.65	28.15	I	I
15304730	C7	-	-	0.3 X 35.75	0.3 X 36.12	COPPER ALLOY	0.35 - 0.5	21	1.85 - 1.2	101	2.1	28.15	I	I

DELPHI
DELPHI PACKARD ELECTRICAL/ELECTRONIC ARCHITECTURE

WARREN, OH
COPYRIGHT 1996 DELPHI CORPORATION AND/OR ITS AFFILIATES. ALL RIGHTS RESERVED.

THIS DRAWING IS THE PROPERTY OF DELPHI CORPORATION AND CONTAINS DELPHI CONFIDENTIAL INFORMATION. THE REPRODUCTION, DISTRIBUTION AND UTILIZATION OF THIS DOCUMENT OR ITS RELATED CAD DATA, AS WELL AS COMMUNICATION OF ANY CONTENT TO OTHERS, WITHOUT EXPRESS AUTHORIZATION, IS PROHIBITED.

APVD1 N. VEROARA 06JN96
APVD2 T. STEELE 08JN96
APVD3 S.C. HSIEH 28JN96
APVD4

SUBSTANCES OF CONCERN AND RECYCLED CONTENT PER DELPHI (04/0001)

DRAWING NAME
TAXI TERM M GT 280 SEALED

DRAWING NUMBER
15304726

SIZE A0 SCALE 10:1 FRM NO 1 OF 1 SHEET NO 1 OF 1 STG REV N/P 16 - 1

DIMENSIONS ENCLOSED IN () INDICATE REFERENCE DIMENSIONS AND NO TOLERANCE LIMITS ARE ESTABLISHED		CHART ID	THIRD ANGLE PROJECTION	DO NOT USE MATH DATA
FROM	TO	10		
0	> 12			
TOLERANCE UNLESS OTHERWISE SPECIFIED		±0.1		
ANGULAR TOLERANCE ±2°				