



HY-42Q101CC Bluetooth Low Energy Module Specification

(Qualified for automotive applications)

13.Aug. 2020

Version : V1.1

Copyright © 2010-2019 SHENGRUN Technology Co., Ltd.All rights reserved.

SHENGRUN Technologies assumes no responsibility for any errors which may appear in this manual, Furthermore, SHENGRUN Technologies reserves the right to alter the hardware, software, and/or specifications detailed here at any time without notice and does not make any commitment to update the information contained here.

SHENGRUN's products are not authorized for use as critical components in life support devices or systems.

SHENGRUN Technologies assumes no responsibility for any patents or authorized the use of intellectual property rights.

The *Bluetooth* trademark is owned by the Bluetooth SIG Inc., USA

CONTENTS

1. DESCRIPTION	1
1-1.APPLICATIONS:	1
1-2.KEY FEATURES:	1
2. HARDWARE MODEL DESCRIPTION	2
3. DIMENSION & PIN FUNCTION	2
4.APPLICATION NOTE	2
5. PIN OUT AND GPIO FUNCTION DESCRIPTION	5
6. ELECTRICAL CHARACTERISTICS	6
6-1.RADIO PERFORMANCE&CURRENT CONSUMPTION	6
6-2. ABSOLUTE MAXIMUM RATINGS	7
6-3. ESD RATINGS	7
6-4. RECOMMENDED OPERATING CONDITIONS	7
6-5.GPIODC CHARACTERISTICS	8
7. BLOCK DIAGRAM	8
8. FUNCTIONAL BLOCK DIAGRAM	8
9. WORKING MODE SCHEMATIC	9
10. CERAMIC ANTENNA SPECIFICATION	9
11. RECOMMEND REFLOW PROFILE	11
12. CONTACT US	12

1. Description

HY-42Q101CC is a Bluetooth low energy single-mode module that meets the AEC-Q100 automotive specification level 2 temperature range (-40°C~+105°C).

HY-40Q101 Bluetooth low energy single-mode module for car specification is a Bluetooth device for low-power sensors and message transmission.

HY-42Q101CC provides Bluetooth low energy features: radio, Bluetooth protocol stack, configuration files and required space for customer applications. The module also provides a flexible hardware interface for connecting sensors.

HY-42Q101CC can be directly powered by a standard 3V button battery or a pair of AAA batteries. In the lowest power shutdown mode, it only consumes 0.15uA and wakes up within a few microseconds.

Use Simple Link Bluetooth® 5.1 Low Energy Wireless MCU :TI CC2642R-Q1 7*7*0.9mm 48pin IC , Frequency Synthesizer Cryster : 48MHz

1-1.APPLICATIONS:

Automotive

- Car access and security systems
- Passive entry passive start (PEPS)
- Phone as a key (PaaK)
- Remote keyless entry (RKE)
- Battery management system (BMS)
- Advanced driver assistance systems (ADAS)
- Telematics control unit (TCU)
- Head unit

Industrial

- Industrial transport - asset tracking
- Factory automation and control

1-2.KEY FEATURES:

- Bluetooth BLE single mode compliant
- Supports master,slave and master/slave modes
- Integrated Bluetooth low energy stack

- GAP, GATT, L2CAP, SMP Bluetooth low energy profiles
- Suitable for systems targeting compliance: BQB BLE5.0,FCC,IC(Canada),CE ETSI RED,etc.worldwide RF Regulations.
- Ultra low current consumption :Shutdown. No clocks running, no retention: 150 nA(Typical)
- Programmable ARM Cortex-M4F processor for embedding full applications
- 352KB of in-system Programmable Flash
- 256KB of ROM for protocols and library functions
- 8KB of Cache SRAM (Alternatively available as general-purpose RAM)
- 80KB of ultra-low leakage SRAM. The SRAM is protected by parity to ensure high reliability of operation.

2. Hardware Model Description

Use TI CC2642R2 integrated chip,Optional with shield case or no shield case)

No.	PCBAModel.	Description
1	HY-42Q101CC	Ceramic Antenna with shield case

3. Dimension & PIN Function

(PCBA dimension size : 25.21 * 15.21 * 2.0/2.7 mm).

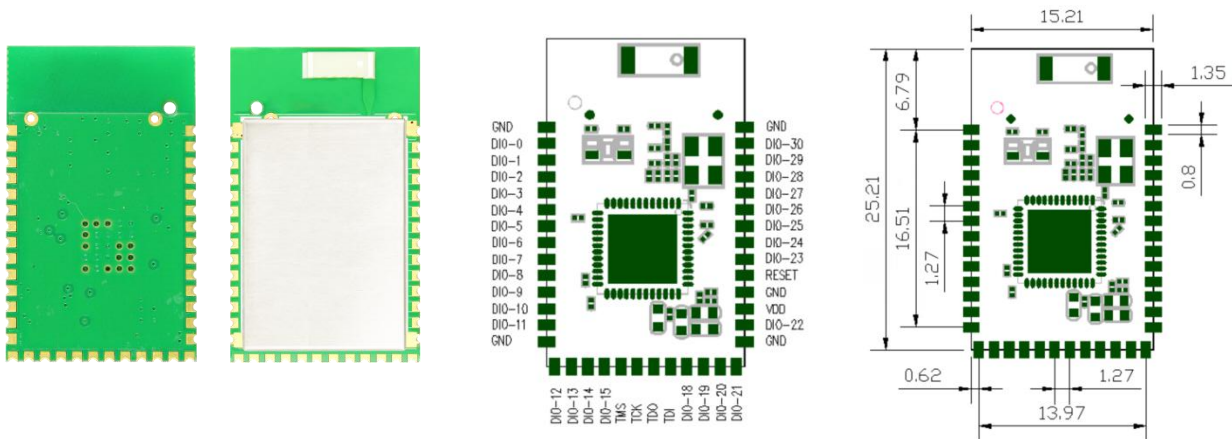

4.Application Note

- 4-1.Attention to the electrostatic protection, prevent the soldering iron and the equipment grounding bad; And the workbench, working environment,packaging materials and from the human body Touch with static electricity,etc., destroy IC and software to be flied; Manual welding module solder iron temperature, should pay attention to avoid the PCB copper Stripping off;Soldering iron strictly Grounding requirements, eliminating solder iron leak Voltage and **avoid supply power VCC switch instant turn on/ turn off state** ,generate high voltage, Maybe let the module to damaged;

4-1a. Soldering iron front end to ground resistance under the 10 Ω, and leakage voltage < 0.1 V; The environment and Personnel static voltage shall be within 0±100V. Anti-static labeling shall be show in the operation area. And use high efficiency ionizing blower go to eliminate static voltage of the product during operation.

4-2. Attention to avoid the overall motherboard power supply circuit of bad welding connected to short circuit or open circuit, causing the Bluetooth chip, abnormal voltage, The software will fly and problems of IC was damaged.

4-3. When programming firm ware , the VDD5 supply voltage must in DC 2.4~3.3V, To avoid programming has not completely, and abnormal status occur.

4-4. Avoid supply voltage in (BOD Brown - Out Detect) fall within the scope of electrical detection threshold(1.76 V ~ 1.78 V) occurred many times, (diagram below off electric Lock - up area) firmware may be locked.

Cause the Boot Code start up Code suspended, unable to connect to the JTAG protocol; In case of this state is available use Reset pin action under 1.0 V, to remove this phenomenon; The rechargeable batteries at charge-discharge status; In the application at the same time, to ensure the voltage setting of the protection system; And pay attention to the supply of power caused by the internal resistance and line impedance voltage drop; And make sure that The equipment operating voltage from 2.0 V to 3.6 V, and ensure that the voltage slope faster than 0.5 V/ms (through BOD threshold).

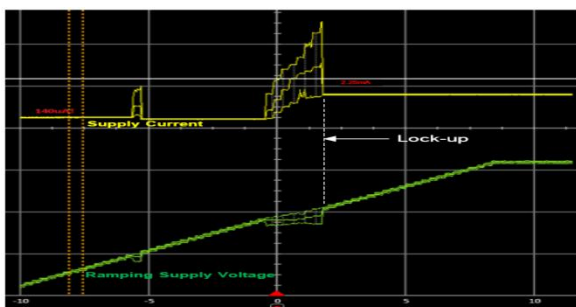

4-5. Use the module in the production and the transport process, please insure module's component protection, prevent the precision parts on the module Damaged (welding furnace exit and assembly, testing, delivery process, suggest using collision buffer material, not collide with each other)

4-6. The module for the humidity sensitive components, if used in SMT reflow soldering operations,

please strictly follow the IPC/JEDECJ - STD – 020 regulation, completes the drying dehumidifying , and for this module has second processing work after placed in the functional test environment, the humidity of the chip is no guarantee that in a certain ratio, the honored guest please understand; (The attention note show in below Fig.)



4-7. The diagram (show in below Fig.) of the module application on external filter parts, when need, please design in the main board, the parts parameter can depend on the actual need to changes. And pay attention to the increase and decrease ramping of supply voltage fast than 0.5v/ms;

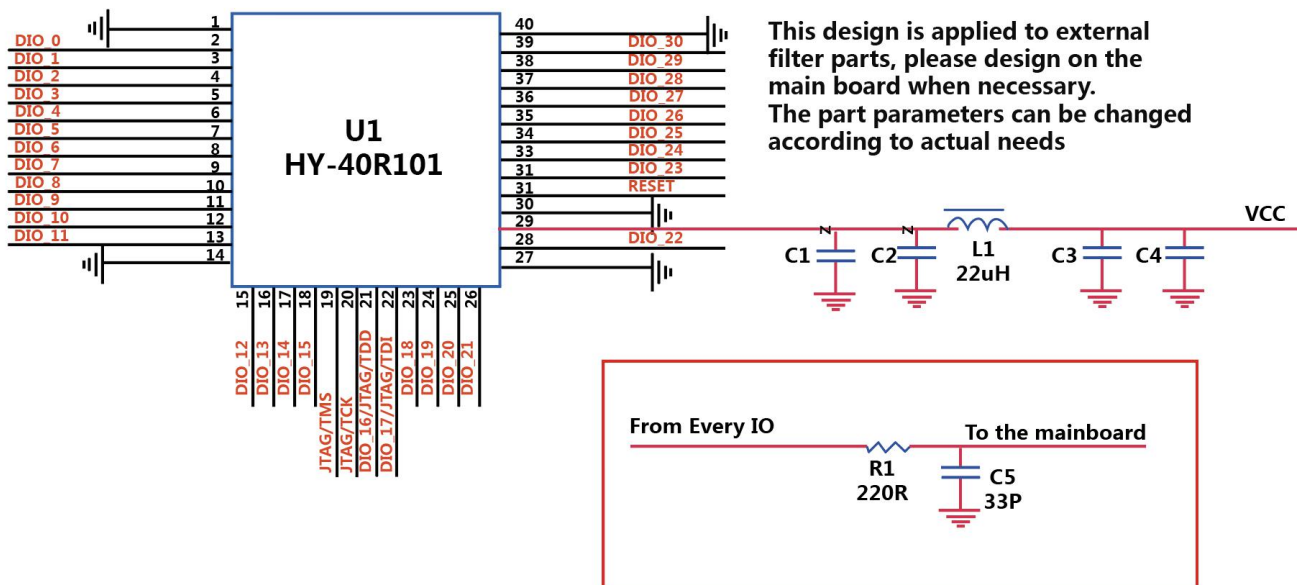

4-8. Assembly recommendation 1: Underneath the module antenna and RF circuit on the main board PCB copper need to clearance, and place close to the main board edge, as show in below Fig. The antenna can't be near around metal parts and prevent material existence of electromagnetic radiation , Can affect the manipulation of the distance.

4-9. Assembly recommendation 2: Signal trace and power supply trace, don't cross layout, as show in below Fig. To avoid cross talk, affect the receiving sensitivity.

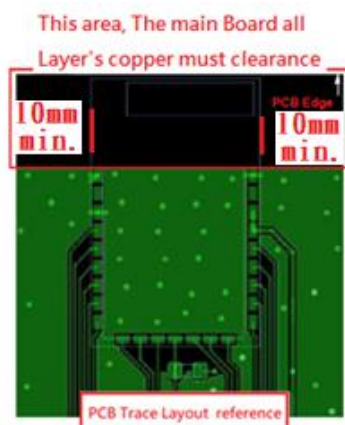
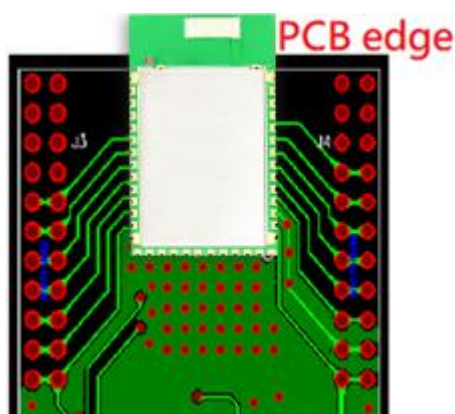

If the PCB not ground isolation signals between different layers, Trace do not intersect between different layers layout, prevent crosstalk
若 PCB不同層間沒有接地面隔離信號, 不同層間的線路不要交叉布局,防止串擾.

The module assemble in the motherboard, must pay attention to: Around the antenna and all layer's copper must be clear, Module antenna should be on the edge, And there are no metal or obstruct electromagnetic radiation material to surround antenna area.

5. Pin out and GPIO function Description

Pin	Name	Type	Function Description
1	GND	Power GND	Ground
2	DIO_0	Digital I/O	GPIO, Sensor Controller (I:4mA max)
3	DIO_1	Digital I/O	GPIO, Sensor Controller (I:4mA max)
4	DIO_2	Digital I/O	UART RX; GPIO, Sensor Controller (I:4mA max)
5	DIO_3	Digital I/O	UART TX; GPIO, Sensor Controller (I:4mA max)
6	DIO_4	Digital I/O	WAKE UP; Don't floating GPIO, Sensor Controller (I:4mA max)
7	DIO_5	Digital I/O	GPIO, Sensor Controller, high-drive capability (8mA max).
8	DIO_6	Digital I/O	GPIO, Sensor Controller, high-drive capability (8mA max).
9	DIO_7	Digital I/O	GPIO, Sensor Controller, high-drive capability (8mA max).
10	DIO_8	Digital I/O	GPIO (I: 4mA max)
11	DIO_9	Digital I/O	GPIO (I: 4mA max)
12	DIO_10	Digital I/O	GPIO (I: 4mA max)
13	DIO_11	Digital I/O	GPIO (I: 4mA max)
14	GND	Power GND	Ground
15	DIO_12	Digital I/O	GPIO (I: 4mA max)
16	DIO_13	Digital I/O	GPIO (I: 4mA max)
17	DIO_14	Digital I/O	GPIO (I: 4mA max)
18	DIO_15	Digital I/O	GPIO (I: 4mA max)
19	JTAG TMSC	Digital I/O	JTAG TMSC; high-drive capability
20	JTAG TCKC	Digital I/O	JTAG TCKC
21	DIO_16 TDO	Digital I/O	GPIO,JTAG_TDO; high-drive capability(8mA max).
22	DIO_17 TDI	Digital I/O	GPIO,JTAG_TDI; high-drive capability(8mA max).
23	DIO_18	Digital I/O	GPIO (I: 4mA max)
24	DIO_19	Digital I/O	GPIO (I: 4mA max)
25	DIO_20	Digital I/O	GPIO (I: 4mA max)

26	DIO_21	Digital I/O	GPIO (I: 4mA max)
27	GND	Power GND	Ground
28	DIO_22	Digital I/O	GPIO (I: 4mA max)
29	VDD	Power Supply	+1.8V to +3.8V (Recommended 2.7~3.3V)
30	GND	Power GND	Ground
31	RESET	Digital input	Reset, active-low. Module have pull up.
32	DIO_23	Digital I/O	GPIO, Sensor Controller, Analog(I: 4mA max)
33	DIO_24	Digital I/O	GPIO, Sensor Controller, Analog(I: 4mA max)
34	DIO_25	Digital I/O	GPIO, Sensor Controller, Analog(I: 4mA max)
35	DIO_26	Digital I/O	GPIO, Sensor Controller, Analog(I: 4mA max)
36	DIO_27	Digital I/O	GPIO, Sensor Controller, Analog(I: 4mA max)
37	DIO_28	Digital I/O	GPIO, Sensor Controller, Analog(I: 4mA max)
38	DIO_29	Digital I/O	GPIO, Sensor Controller, Analog(I: 4mA max)
39	DIO_30	Digital I/O	GPIO, Sensor Controller, Analog(I: 4mA max)
40	GND	Power GND	Ground

6. Electrical Characteristics

(Test condition: With Ta = 25 °C, VDD =3.0V with internal DC-DC converter, standard measure:1Mbps 250KHz deviation GFSK modulation ,FRF = 2440MHz Bluetooth Low energy mode.)

6-1.Radio performance¤t consumption

(Test condition:With Ta = 25 °C, VDD =3.0V, with internal DC-DC converter, standard measure:1MbpsGFSKmodulation ,FRF = 2440MHz Bluetooth Low energy mode.)

- Modulation Mode: GFSK
- Frequency range: 2402~2480MHZ (2.4GHz ISM band)
- Transmit power setting Range: -21 ~ +5 dBm typical (programmable by software) .
- The antenna feed point transmit power: +2 dBm typ. (TX set Max.output)
- The antenna feed point receiver sensitivity : -93 dBm typical. (PER <30.8%)
- Frequency drift specification:RF ± 60ppm , MCU clock 32.768KHz± 350ppm.(Use X-Tal)
- Suitable for systems targeting compliance:FCC,IC(Canada),CE ETSI RED,BQB,... etc. worldwide RF Regulations.
- Ultra low current consumption
 - Transmit : 7.3mA(typical) (O/P Power setting :0dBm)
 - Transmit : 9.6mA(typical) (O/P Power setting :5dBm)
 - Receive(high gain setting): 6.9 mA(typical)
 - Active-Mode MCU 48 MHz (Core Mark):3.4 mA (71 μA/MHz)
 - Standby: RTC on, 80KB RAM and CPU retention: 0.94 uA(Typical)

- Shutdown. No clocks running, no retention: 150 nA(Typical)

6-2. Absolute Maximum Ratings

Note: These are absolute maximum ratings beyond which the module can be permanently damaged, these are not Maximum operating conditions, the maximum recommended operating conditions are in the table 6.

Rating	Min	Max	Unit
VDDS	-0.3	3.8	V
Other Terminal Voltages	VSS-0.3	VDDS+0.3	V
Storage Temperature	-40	+85	°C

6-3. ESD Ratings

			Value	Unit
V _{ESD} Electrostatic discharge	Human body model (HBM), per ANSI / ESDA / JEDEC JS-001	All pins	±2000	V
	Charged device model (CDM), per ANSI / ESDA / JEDEC JS-002	All pins	±500	

6-4. Recommended Operating Conditions

Supply voltage noise should be less than 10mVpp. Excessive noise at the supply voltage will reduce the RF performance.

Rating	Min	Max	Unit
VDD (when Bluetooth Active)	2.0	3.8	V
VDD(when flash programming)	2.4	3.6	V
Operating Temperature Range	-40	+105	°C

Note: (1).VDD power supply recommended voltage : 2.7~3.3V

(2).When programming firm ware , the VDD supply voltage must in DC 2.4~3.6V,

To avoid programming has not completely, or abnormal status occur..

(3).For smaller coin cell batteries, with high worst-case end-of-life equivalent source resistance, a 22-μF VDDS input capacitor must be used to ensure compliance with this slew rate(6-6 timing req.).

6-5.GPIODC Characteristics

Parameter	Test Condition	Typical	Unit
GPIO VOH at 8-mA load	IOCURR = 2, high-drive GPIOs only	2.68	V
GPIO VOL at 8-mA load	IOCURR = 2, high-drive GPIOs only	0.33	V
GPIO VOH at 4-mA load	IOCURR = 1	2.72	V
GPIO VOL at 4-mA load	IOCURR = 1	0.28	V

7. Block Diagram

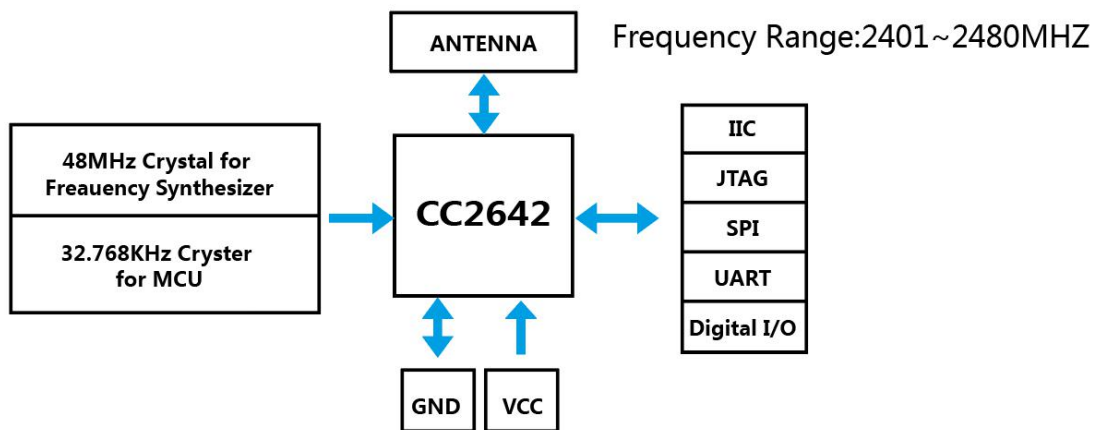

8. Functional Block Diagram



Figure 1-1. CC2642R Block Diagram

9. Working Mode Schematic

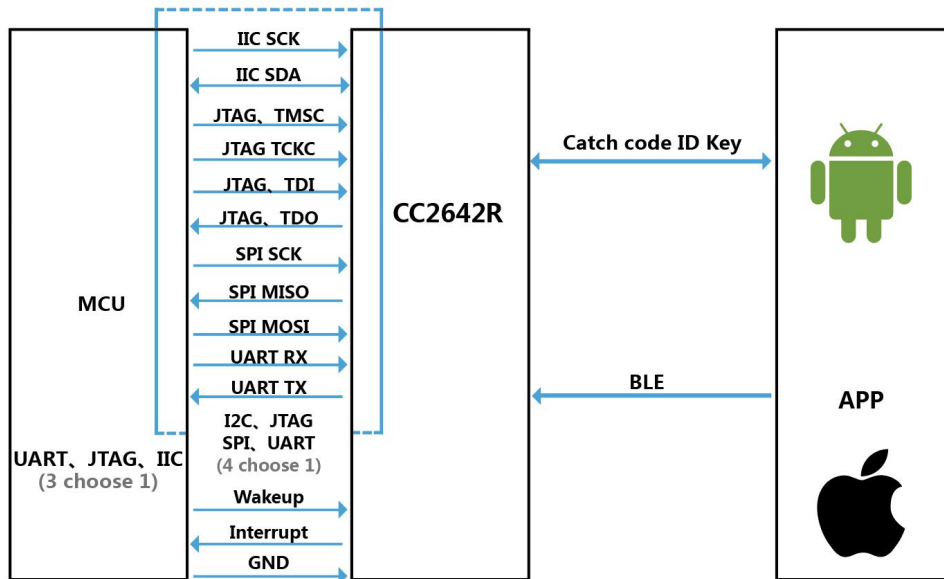

10. Ceramic Antenna Specification

10-1: Antenna peak gain :2.0dBi at 2450MHz

10-2: Antenna Dimensions (unit: mm)

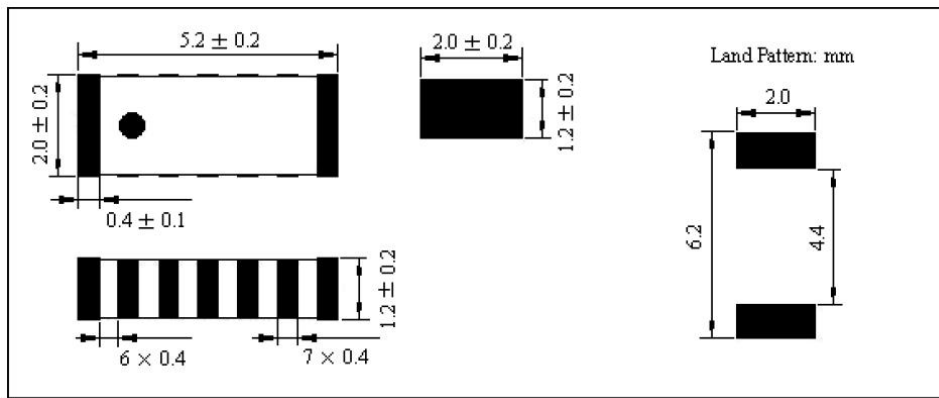

10-3: Radiation Pattern and efficiency

X-Z Plane

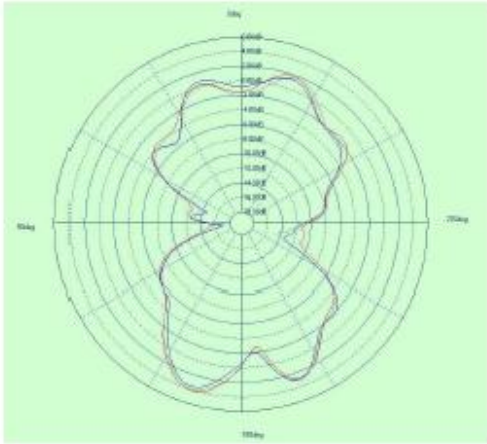

Y-Z Plane

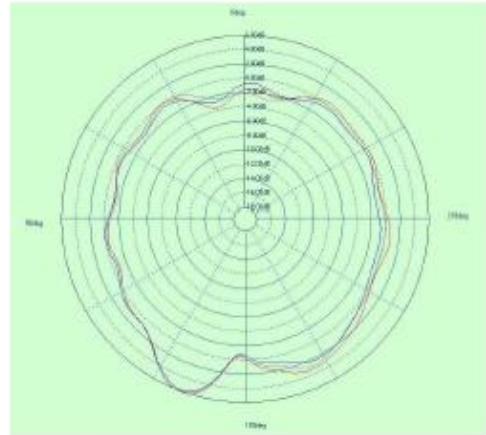

X-Y Plane

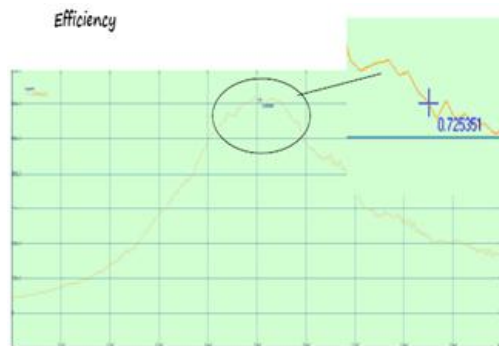
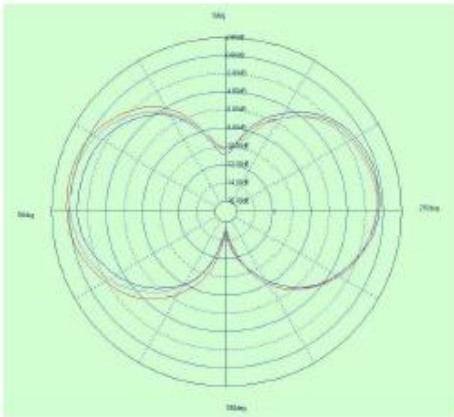

11. Recommend Reflow Profile

(Leadless solder cream: Sn 96.5%, Ag 3%, Cu 0.5%)

Profile Feature	Pb-Free Assembly	
	Large Body	Small Body
Average ramp-up rate(T_L to T_P)	3°C/second max	
Preheat-Temperature Min (T_{Smin})	150°C	
-Temperature Max (T_{Smax})	200°C	
-Time (min to max)(t_s)	60-180 seconds	
T_{Smax} to T_L -Ramp-up Rate	3°C/second max	
Time maintained above-Temperature (T_L)	217°C	
-Time (t_L)	60-150 seconds	
Peak Temperature (T_P)	245 +0/-5°C	250 +0/-5°C
Time within 5°C of actual Peak Temperature (t_p)	10-30 seconds	20-40 seconds
Ramp-down Rate	6°C/second max	
Time 25°C to Peak Temperature	8 minutes max	

Reflow Curve Classification

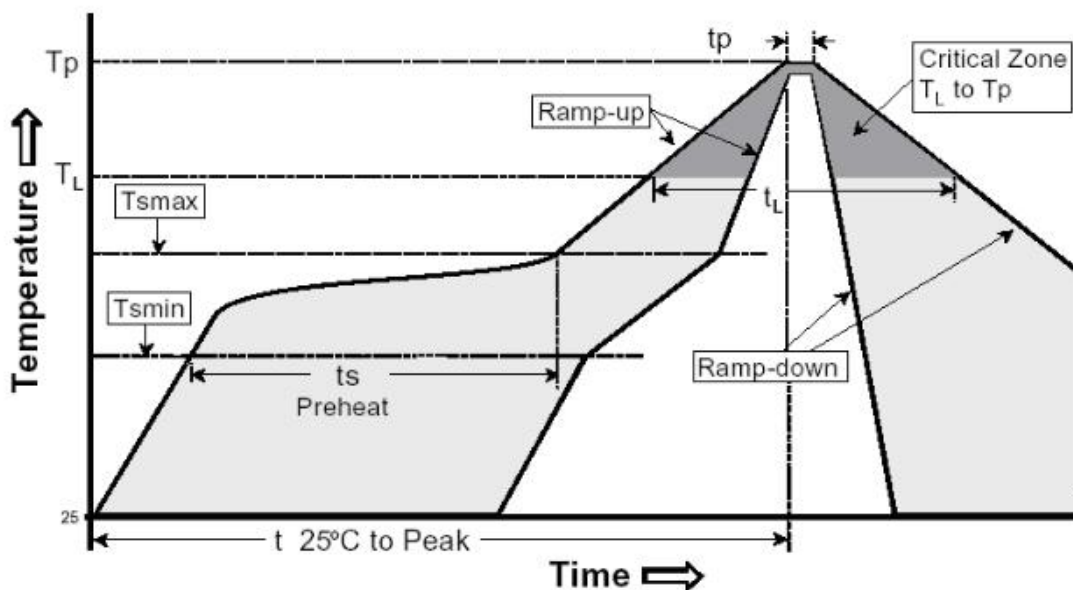

12. Contact Us

ShenZhen ShengRun Technology Co.,Ltd.

Address: Unit 505,Block C,First Building,Smart Park,No.76 Baohe Avenue, Baolong Street,
Longgang District, Shenzhen City, Guangdong Province, China

TEL : +86-0755-86233846

Sales direct phone No. : +86-400-8050-562

E-mail : marketing@ttcble.com

E-shop : <https://tuner168.1688.com/>

Chinese Website : www.tuner168.com

English Website : www.ttcble.com

