

THIS DRAWING IS UNPUBLISHED. RELEASED FOR PUBLICATION
 © COPYRIGHT - By - ALL RIGHTS RESERVED.

LOC		DIST		REVISIONS			
P	LTN	DESCRIPTION		DATE	DN	APD	
AF	50	C3	REVISED PER ECR-20-100299	10AUG2020	BDA	WW	

SUGGESTED MATING TAB

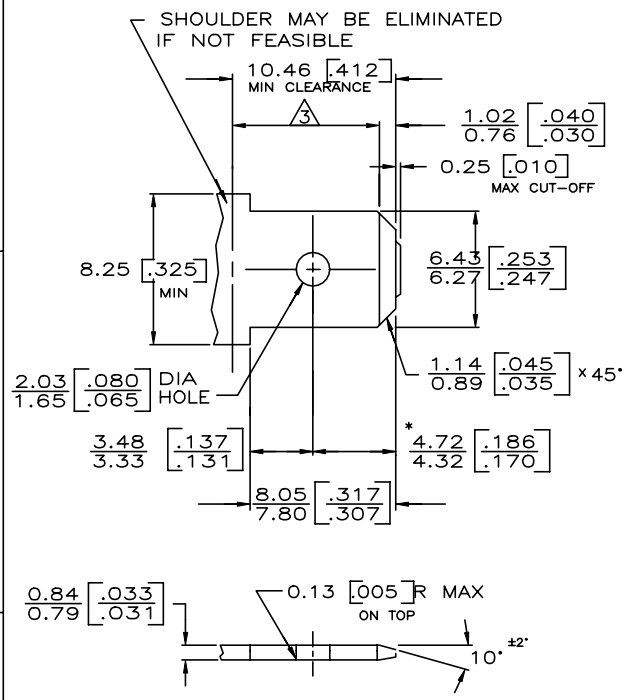

- 1 - MATL: 1/2H BRASS OR NICKEL PL STEEL.
 - 2 - NO BURRS PERMISSIBLE AT HOLE.
 - 3 - MUST BE FLAT WITHIN 0.076 [.003] OVER THIS LENGTH.
 - 4 - TIN PLATING IS REQUIRED ON BRASS WHEN TERMINAL TEMP. IS OVER 225° F.
 - 5 - HOLE MUST BE SYMMETRICAL ABOUT TAB Q̄ WITHIN 0.076 [.003]
- * TO BE USED ONLY WHEN SHOULDER IS ELIMINATED.

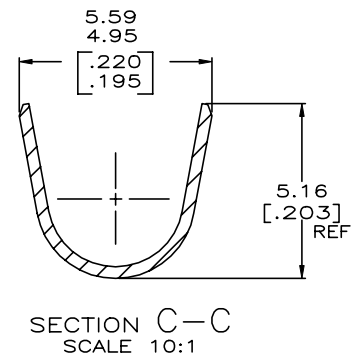
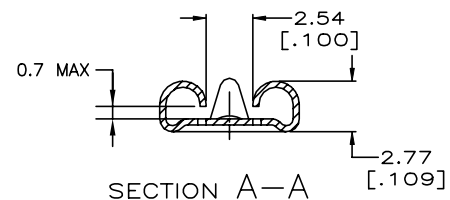
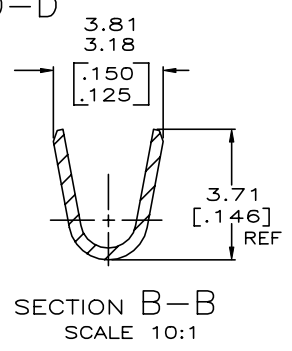
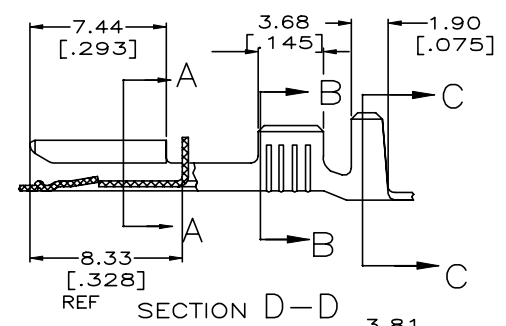
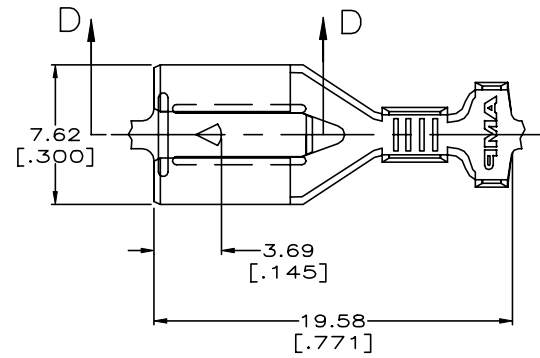

- 1 CONTINUOUS STRIP ON REELS.
- 2 REF CRIMP INFORMATION:
WIRE CRIMP: .110 F TYPE
INSULATION CRIMP .180, F TYPE
- 3 #18-#14 AWG, 2.29-3.94 [.090-.155] DIA OR TWO #18'S WITH 1.90 [.075] MAX INSULATION
- 4 PRELIMINARY - NOT FOR PRODUCTION

SILVER 0.00381 [.000150] MIN	4 1217094-3
TIN 0.002032 [.000080] MIN	1217094-2
-	1217094-1
FINISH	PART NO

THIS DRAWING IS A CONTROLLED DOCUMENT.		DRW: JR RUTH 6/19/98	TE Connectivity	
DIMENSIONS: MM [INCHES]		CHK: MS FEHER 6/19/98	RECEPTACLE, POSITIVE LOCK, 6.35 [.250] SERIES	
TOLERANCES UNLESS OTHERWISE SPECIFIED:		APD: J GILLISPIE 6/19/98	SIZE: A2 CAGE CODE: 00779 C=1217094	
0 PLC ± -	1 PLC ± -	PRODUCT SPEC: -	RESTRICTED TO: -	
2 PLC ± -	3 PLC ± -	APPLICATION SPEC: 114-2074	SCALE: 5:1 SHEET: 1 of 1	
4 PLC ± -	ANGLES ± -	WEIGHT: -	REV: C3	
MATERIAL: H06 BRASS	FINISH: SEE TABLE	CUSTOMER DRAWING		