

REV.	DESCRIPTION	DATE	DWN	AP'PD
0		11.2.15	Ye	Liu
1.0	Correct appearance	13.12.30	Guo	Wu

## 一、Mechanicals Dimensions

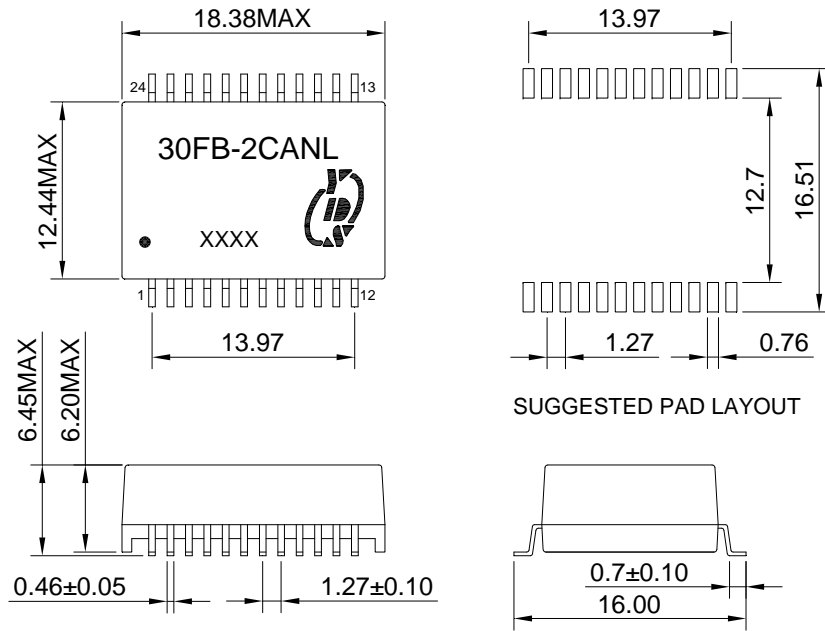

UNIT: mm Unless otherwise specified, all tolerances are  $\pm 0.25$

## 二、Schematics

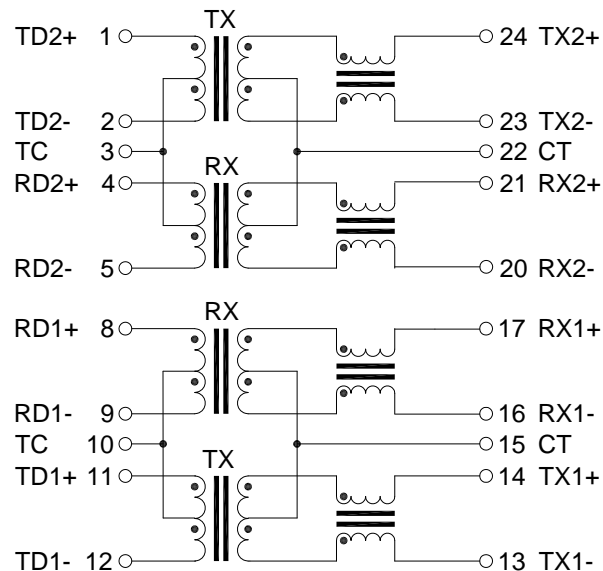

## 三、ELECTRICAL SPECIFICATIONS @25°C:

1. Turn Ratio( $\pm 5\%$ ):1CT:1CT
2. Inductance(100KHz/0.1V@8mA):350uH MIN
3. Insertion Loss (dB MAX):-1.1dB(100KHz-100MHz)
4. Return Loss (dB MIN): -20dB(30MHz),-14dB(60MHz),-11dB(80MHz),
5. Cross talk(dB TYP): -45dB(1-30MHz),-35dB(60-100MHz)
6. DCMR (dB TYP): -37dB(30-50MHz),-30dB(100MHz)
7. HI-POT:1500Vrms/0.5mA/60Sec or 1650Vrms/0.5mA/2Sec
8. Operating Temperature:-40°C TO +85°C
9. RoHS compliance:YES

Ref:C1630

	<b>元册科技股份有限公司</b> YUAN DEAN SCIENTIFIC CO., LTD.			
	TITLE		10/100 BASE-T MAGANETIC MODULE	
	P/N	30FB-2CANL	REV.	1.0
	PAGE NO	1-3	DATE	2013-12-30
	AP'PD	Wu Zhao Ming	DWN	Guo Hai Jin

四、Our RoHS parts just can withstand IR Reflow peak temperature: 245degC+/-5degC as the following profile:

REV.	DESCRIPTION	DATE	DWN	AP'PD

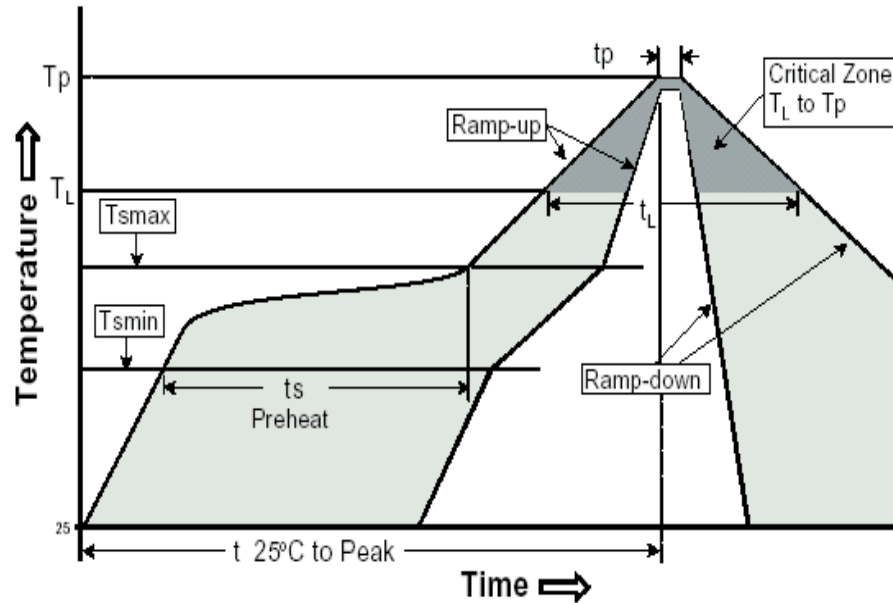
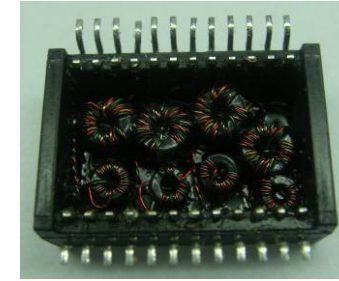
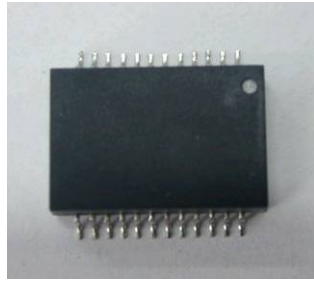

Profile Feature	Pb-Free Assembly
Average Ramp-Up Rate ( $T_{s_{max}}$ to $T_p$ )	3°C /second max.
<b>Preheat</b> -Temperature Min ( $T_{s_{min}}$ ) -Temperature Max ( $T_{s_{max}}$ ) -Time ( $t_{s_{min}}$ to $t_{s_{max}}$ )	150°C 200°C 60-180 seconds
<b>Time maintained above:</b> -Temperature ( $T_L$ ) -Time ( $t_L$ )	217°C 60-150 seconds
Peak/Classification Temperature ( $T_p$ )	245±5°C
Time within 5°C of actual Peak Temperature ( $t_p$ )	20-40 seconds
Ramp-Down Rate	6°C/seconds max
Time 25°C to Peak Temperature	6minutes max.



元册科技股份有限公司

YUAN DEAN SCIENTIFIC CO., LTD.

TITLE

10/100 BASE-T MAGANETIC MODULE

P/N

30FB-2CANL

REV.

1.0

PAGE NO

2-3

DATE

2013-12-30

AP'PD

Wu Zhao Ming

DWN

Guo Hai Jin

## 五、 Packing Information:

- 1.Weight-----2.1 grams/pcs
- 2.Tape & Reel----- 400 pcs
3. outer carton unit: 3200pcs/box
4. outer carton unit: 8T&R/box
- 5.Weight: 11.5kg per carton

REV.	DESCRIPTION	DATE	DWN	AP'PD

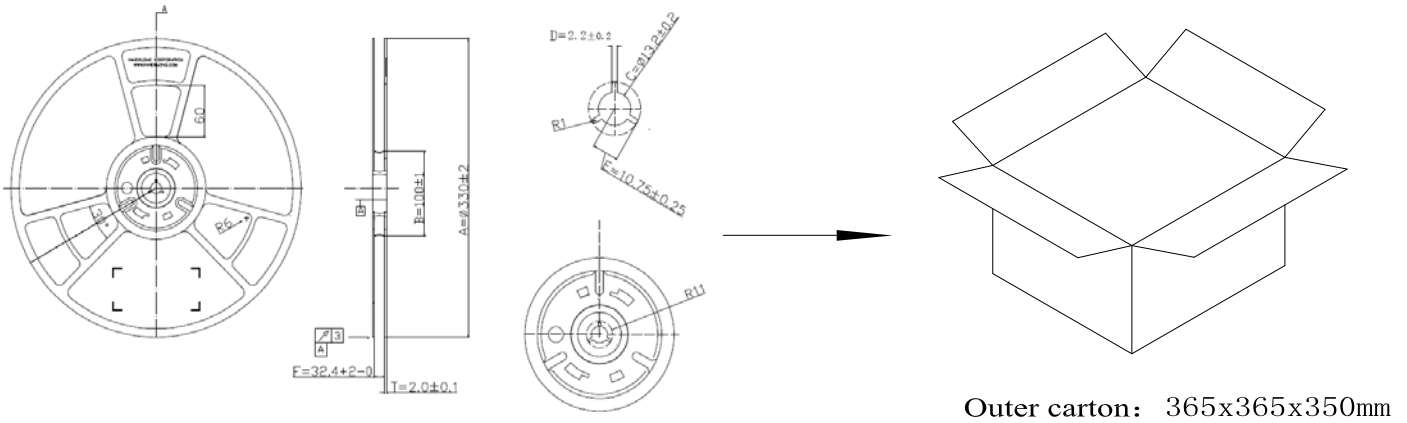
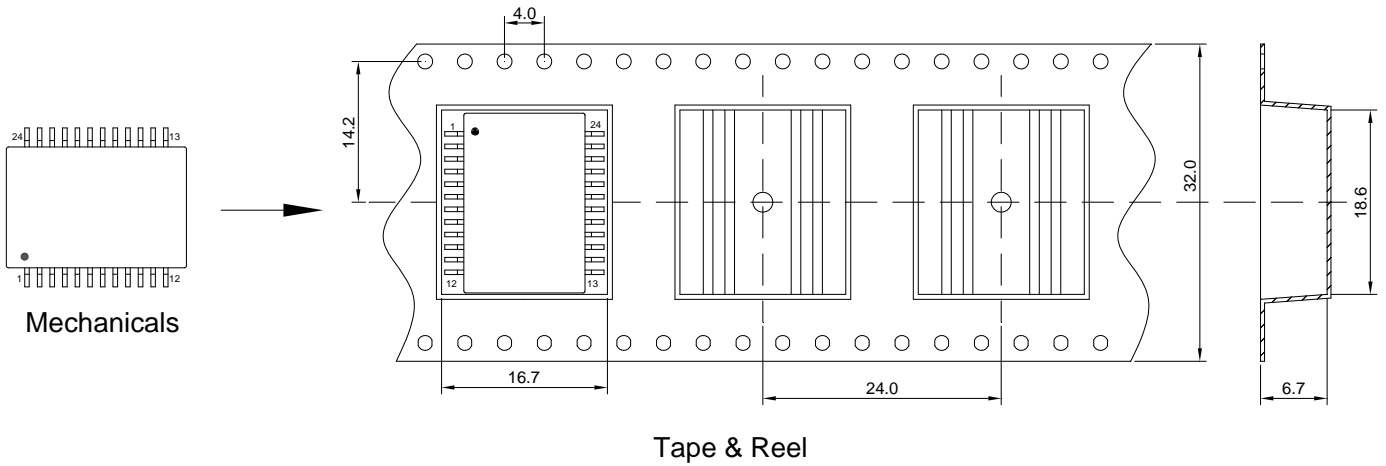

元册科技股份有限公司

YUAN DEAN SCIENTIFIC CO., LTD.

TITLE	10/100 BASE-T MAGANETIC MODULE		
P/N	30FB-2CANL	REV.	1.0
PAGE NO	3-3	DATE	2013-12-30
AP'PD	Wu Zhao Ming	DWN	Guo Hai Jin