

Features

- 30V/30A,
 $R_{DS(ON)} = 7m\Omega(Typ.)@V_{GS}=10V$
 $R_{DS(ON)} = 10m\Omega(Typ.)@V_{GS}=4.5V$
- Super High Dense Cell Design
- Fast Switching Speed
- Low gate Charge
- 100% avalanche tested
- Lead Free and Green Devices Available (RoHS Compliant)

Pin Description

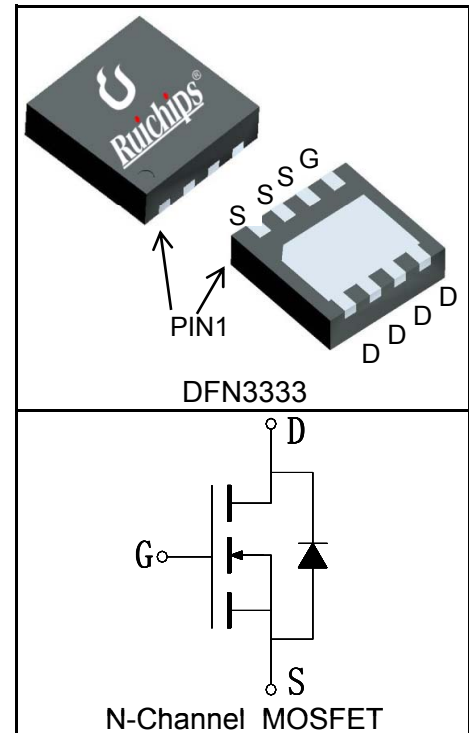

Applications

- Switching Application Systems

Absolute Maximum Ratings

Symbol	Parameter	Rating	Unit
Common Ratings ($T_C=25^\circ C$ Unless Otherwise Noted)			
V_{DSS}	Drain-Source Voltage	30	V
V_{GSS}	Gate-Source Voltage	± 20	
T_J	Maximum Junction Temperature	150	$^\circ C$
T_{STG}	Storage Temperature Range	-55 to 150	$^\circ C$
I_S	Diode Continuous Forward Current	$T_C=25^\circ C$ 30	A
Mounted on Large Heat Sink			
$I_{DP}^{①}$	300 μs Pulse Drain Current Tested	$T_C=25^\circ C$ 120	A
$I_D^{②}$	Continuous Drain Current@ $T_C(V_{GS}=10V)$	$T_C=25^\circ C$ 30	A
		$T_C=100^\circ C$ 19	
	Continuous Drain Current@ $T_A(V_{GS}=10V)^{③}$	$T_A=25^\circ C$ 10.8	
		$T_A=70^\circ C$ 8.7	
P_D	Maximum Power Dissipation@ T_C	$T_C=25^\circ C$ 29	W
		$T_C=100^\circ C$ 12	
	Maximum Power Dissipation@ $T_A^{③}$	$T_A=25^\circ C$ 3.5	
		$T_A=70^\circ C$ 2.3	

Symbol	Parameter	Rating	Unit
$R_{\theta JC}$	Thermal Resistance-Junction to Case	4.2	°C/W
$R_{\theta JA}^{(3)}$	Thermal Resistance-Junction to Ambient	35	°C/W
Drain-Source Avalanche Ratings			
$E_{AS}^{(4)}$	Avalanche Energy, Single Pulsed	42	mJ

Electrical Characteristics ($T_C=25^\circ\text{C}$ Unless Otherwise Noted)

Symbol	Parameter	Test Condition	RU3030M3			Unit
			Min.	Typ.	Max.	
Static Characteristics						
BV_{DSS}	Drain-Source Breakdown Voltage	$V_{GS}=0V, I_{DS}=250\mu A$	30			V
I_{DSS}	Zero Gate Voltage Drain Current	$V_{DS}=30V, V_{GS}=0V$			1	μA
		$T_J=125^\circ\text{C}$			30	
$V_{GS(th)}$	Gate Threshold Voltage	$V_{DS}=V_{GS}, I_{DS}=250\mu A$	1.2		2.5	V
I_{GSS}	Gate Leakage Current	$V_{GS}=\pm 20V, V_{DS}=0V$			± 100	nA
$R_{DS(ON)}^{(5)}$	Drain-Source On-state Resistance	$V_{GS}=10V, I_{DS}=20A$		7	9	$m\Omega$
		$V_{GS}=4.5V, I_{DS}=16A$		10	14	$m\Omega$
Diode Characteristics						
$V_{SD}^{(5)}$	Diode Forward Voltage	$I_{SD}=20A, V_{GS}=0V$			1.2	V
t_{rr}	Reverse Recovery Time	$I_{SD}=20A, dI_{SD}/dt=100A/\mu s$		15		ns
Q_{rr}	Reverse Recovery Charge			8		nC
Dynamic Characteristics⁽⁶⁾						
R_G	Gate Resistance	$V_{GS}=0V, V_{DS}=0V, F=1\text{MHz}$		1		Ω
C_{iss}	Input Capacitance	$V_{GS}=0V,$ $V_{DS}=15V,$ Frequency=1.0MHz		670		pF
C_{oss}	Output Capacitance			180		
C_{rss}	Reverse Transfer Capacitance			75		
$t_{d(ON)}$	Turn-on Delay Time	$V_{DD}=15V, R_L=0.75\Omega,$ $I_{DS}=20A, V_{GEN}=10V,$ $R_G=3\Omega$		5		ns
t_r	Turn-on Rise Time			10		
$t_{d(OFF)}$	Turn-off Delay Time			15		
t_f	Turn-off Fall Time			4		
Gate Charge Characteristics⁽⁶⁾						
Q_g	Total Gate Charge	$V_{DS}=24V, V_{GS}=10V,$ $I_{DS}=20A$		12		nC
Q_{gs}	Gate-Source Charge			3		
Q_{gd}	Gate-Drain Charge			4		

Notes:

- ① Pulse width limited by safe operating area.
- ② Calculated continuous current based on maximum allowable junction temperature.
- ③ When mounted on 1 inch square copper board, $t \leq 10\text{sec}$.
- ④ Limited by T_{Jmax} , $I_{AS} = 13\text{A}$, $V_{DD} = 24\text{V}$, $R_G = 50\Omega$, Starting $T_J = 25^\circ\text{C}$.
- ⑤ Pulse test; Pulse width $\leq 300\mu\text{s}$, duty cycle $\leq 2\%$.
- ⑥ Guaranteed by design, not subject to production testing.

Ordering and Marking Information

Device	Marking	Package	Packaging	Quantity	Reel Size	Tape width
RU3030M3	RU3030	DFN3333	Tape&Reel	5000	13"	12mm

Typical Characteristics

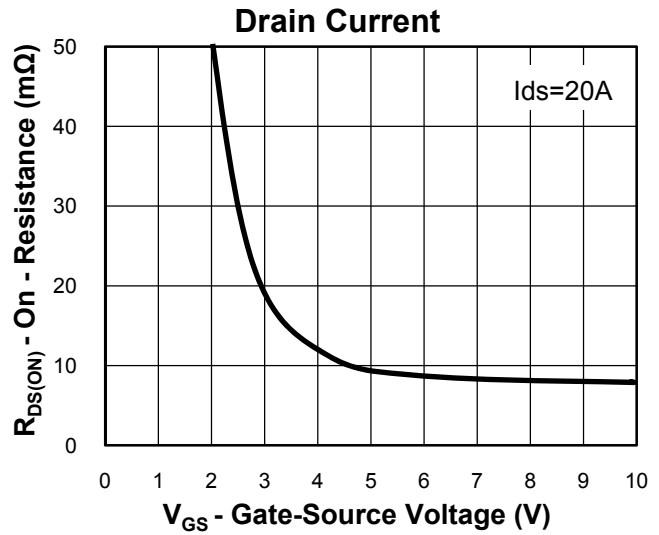
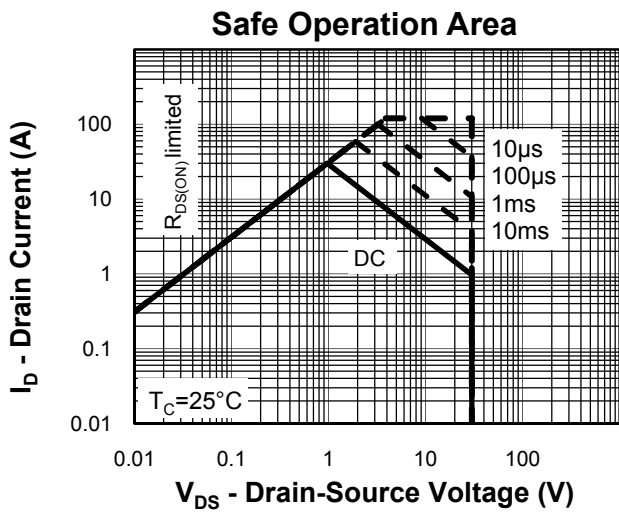
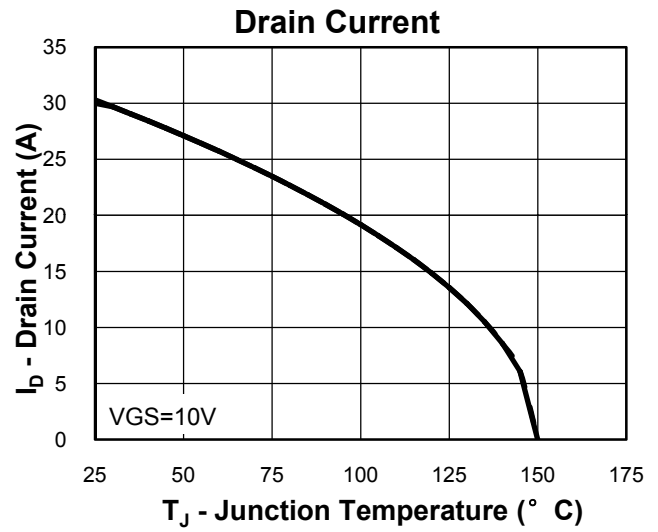
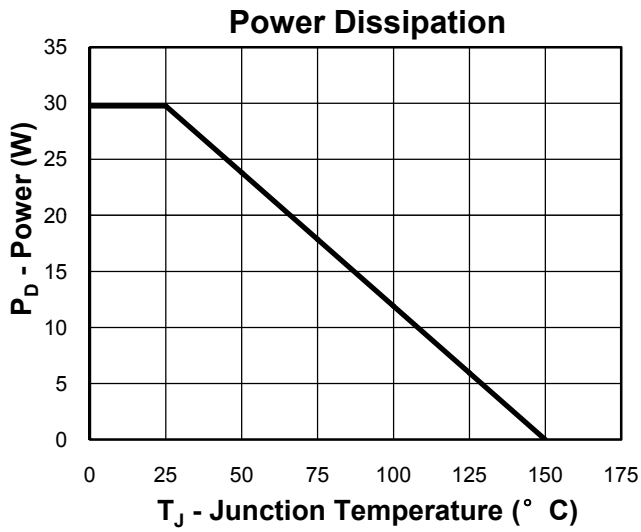

Thermal Transient Impedance

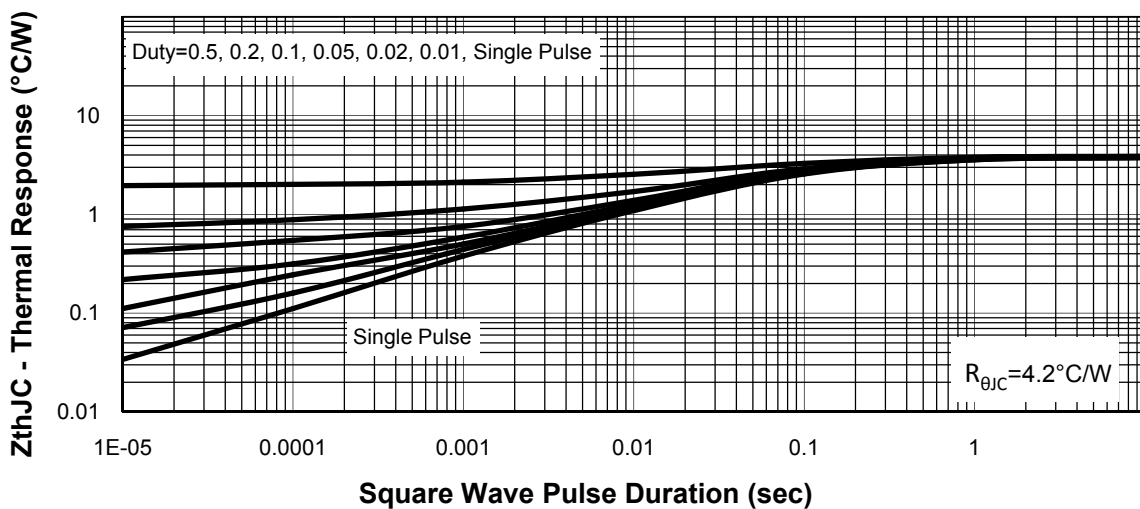

Typical Characteristics

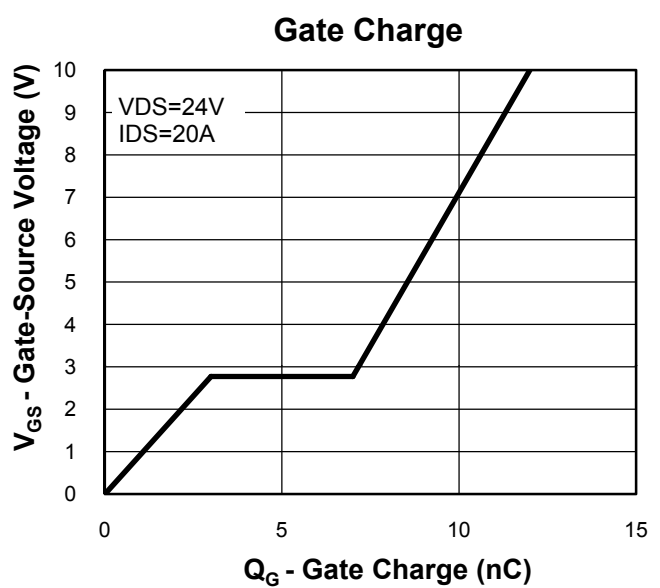
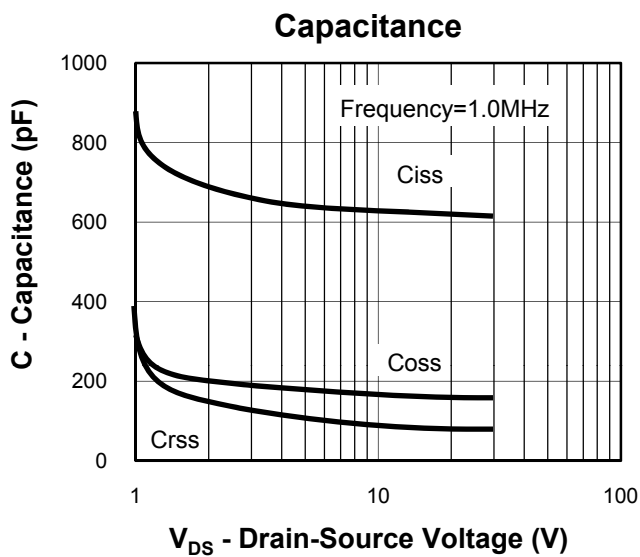
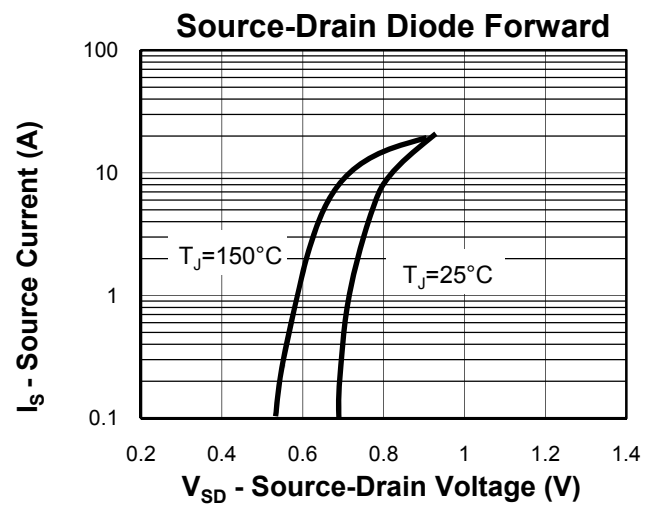
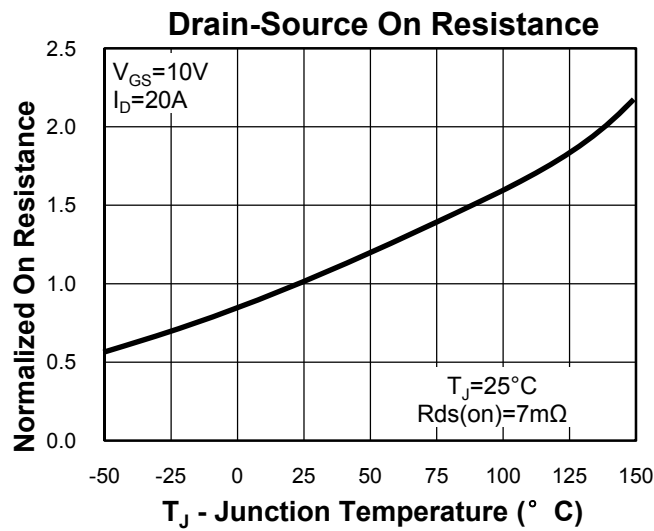
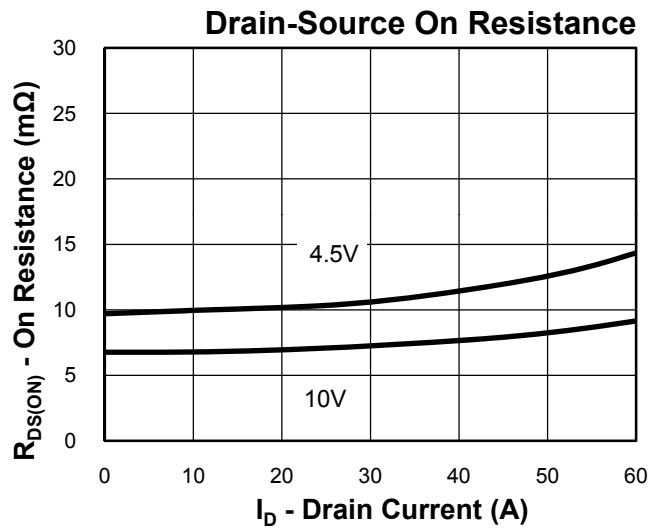
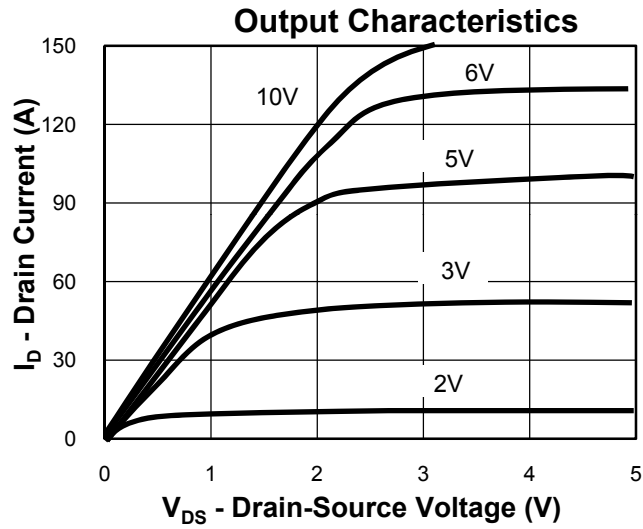

Avalanche Test Circuit and Waveforms

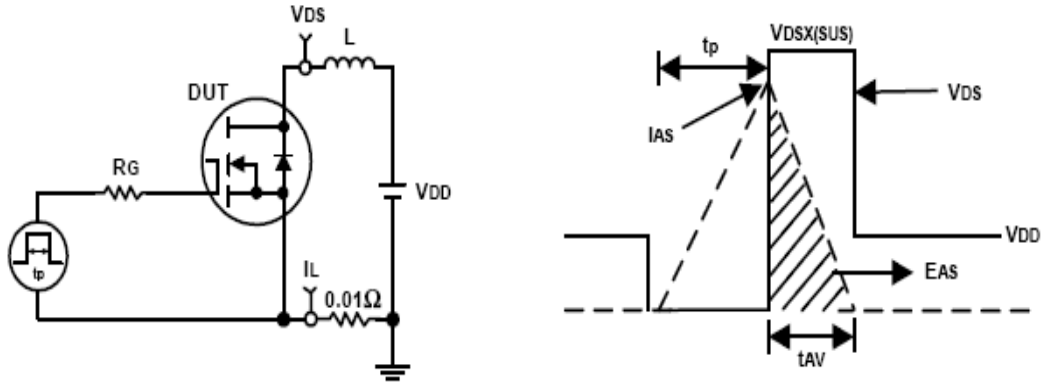

Switching Time Test Circuit and Waveforms

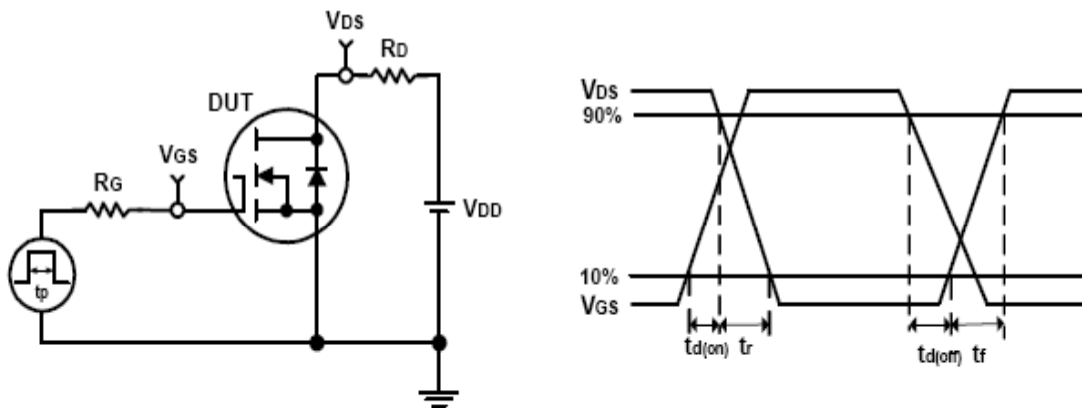

Package Information

DFN3333

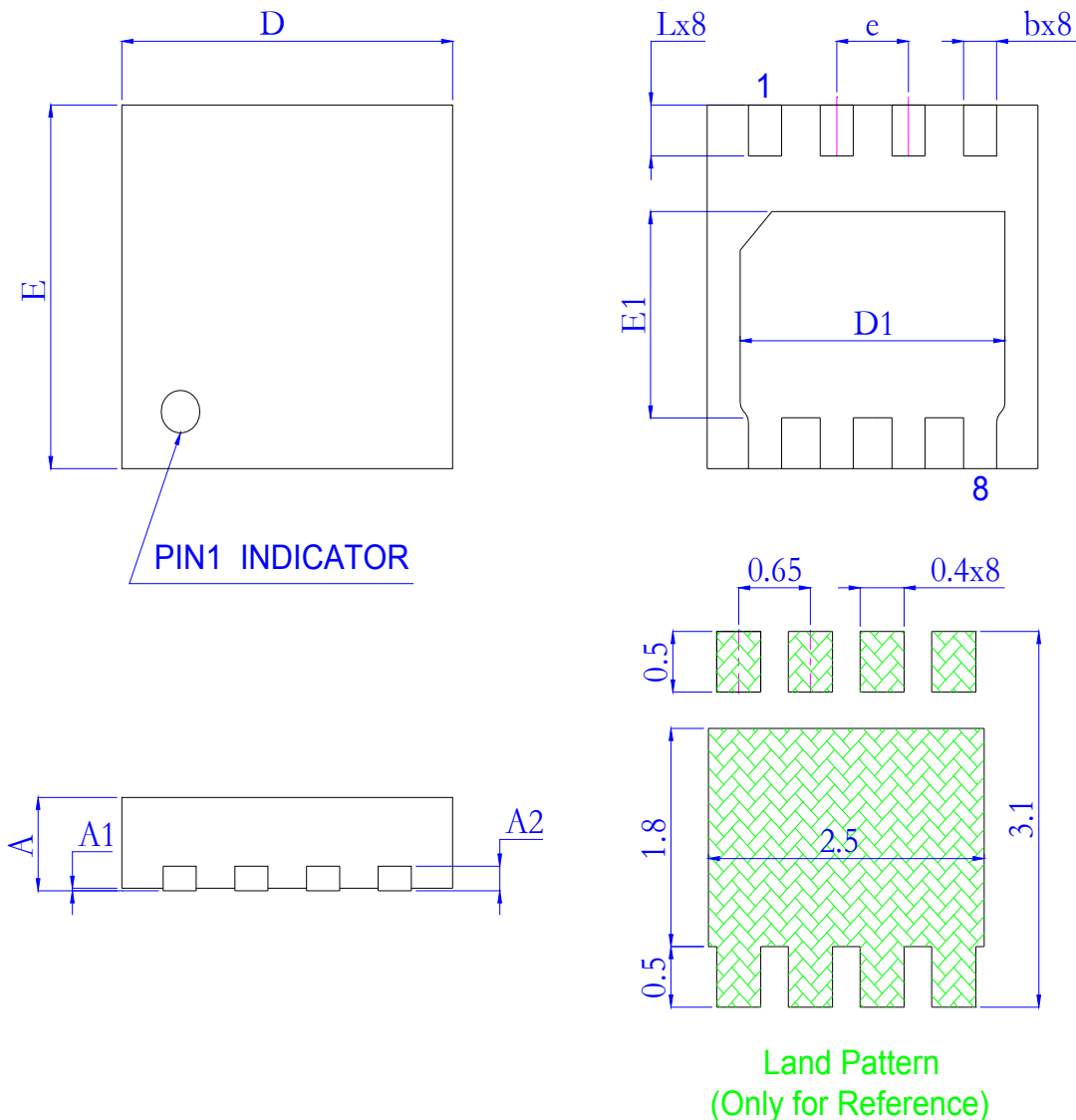

SYMBOL	MM			INCH		
	MIN	NOM	MAX	MIN	NOM	MAX
A	0.700	0.750	0.800	0.028	0.030	0.031
A1	0.000	0.020	0.050	0.000	0.001	0.002
A2	0.203 REF.			0.008 REF.		
b	0.250	0.300	0.350	0.010	0.012	0.014
D	3.000	3.150	3.300	0.118	0.124	0.130
D1	2.350	2.400	2.450	0.093	0.094	0.096
E	3.000	3.150	3.300	0.118	0.124	0.130
E1	1.650	1.700	1.750	0.065	0.067	0.069
e	0.650BSC			0.026BSC		
L	0.370	0.420	0.470	0.015	0.017	0.019