



## CJH0104

### General Description

CJH0104 is a micropower, ultra sensitive hall effect switch. It is mainly designed for battery-powered, hand held equipment.

CJH0104 includes hall sensor, a small-signal amplifier, dynamic offset cancellation and CMOS output. Superior high-temperature performance is made possible through Dynamic Offset Cancellation, which reduces the residual offset voltage normally caused by device package over molding, temperature dependencies, and thermal stresses. Either North or South pole of sufficient strength will turn the output on.

CJH0104 is available in SOT-23-3L packages. The operating temperature is  $-40^{\circ}\text{C}$  to  $150^{\circ}\text{C}$ .

### Features

- ◆ Wide operating voltage, 2~5V
- ◆ Micro power
- ◆ Operating with North or South pole
- ◆ Superior temperature stability
- ◆ Extremely Low Switch-point Drift
- ◆ ESD (HBM) 6000V
- ◆ Small package size

### Application

- ◆ PDA, IPAD
- ◆ Cellular phone

### Function Block Diagram

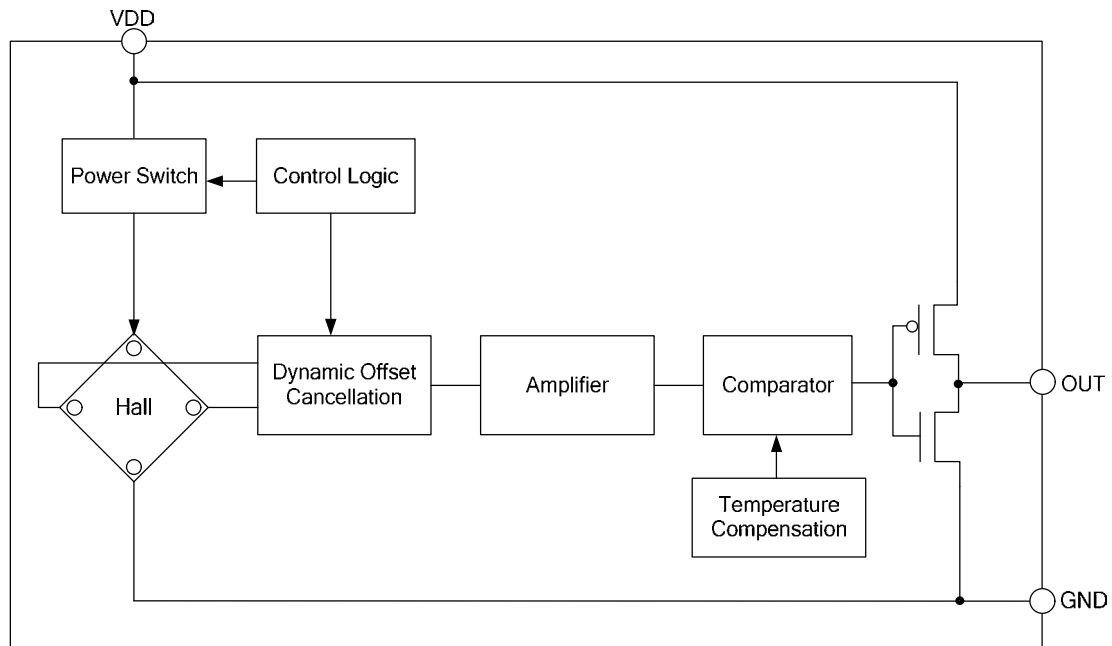

## Ordering Information

Part No.	Packing Form	Package Code
CJH0104	tape reel, 3000 pcs/reel	SOT-23-3L

## Output Voltage VS. Magnetic Pole

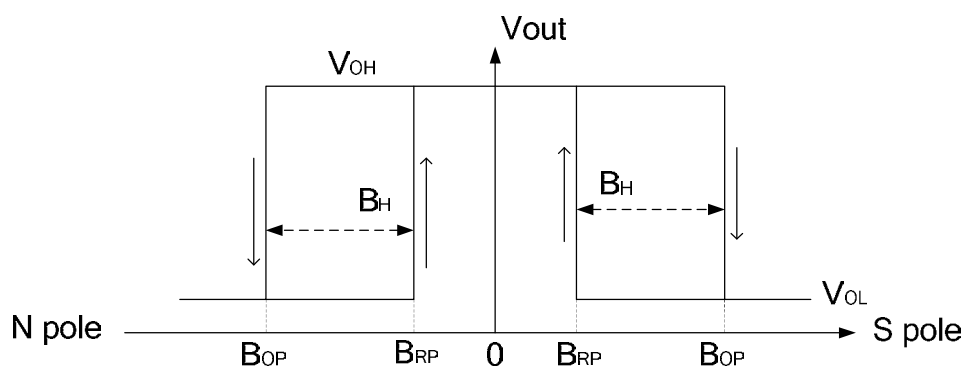

## PIN Configurations

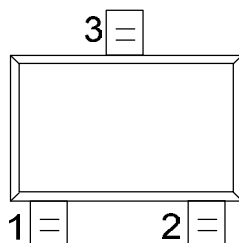

Pin Name	PIN NO.	FUNCTION
	SOT-23-3L	
$V_{DD}$	1	Supply voltage
GND	3	GND
$V_{OUT}$	2	OUT

## Electrical Characteristics

### Absolute Maximum Ratings

Parameter	Symbol	Value	Unit
Supply Voltage	$V_{DD}$	-0.3~5.5	V
Magnetic Flux Density	B	unlimited	Gauss
Junction Temperature	$T_A$	-40~150	°C
Storage Temperature	$T_s$	-50~160	°C
ESD(HBM)		6000	V

### Electrical Parameters ( $V_{DD}=5V$ @ 25°C room temperature, unless specified otherwise)

Parameter	Symbol	Condition	Min	Typ.	Max	Unit
Output High Voltage	$V_{OH}$	$I_{OUT}=0.5mA$	$V_{DD}-0.2$	-	-	V
Output Low Voltage	$V_{OL}$	$I_{OUT}=0.5mA$	-	-	0.2	V
Supply Current	$I_{DD(EN)}$		-	2	-	mA
	$I_{DD(dis)}$		-	3	-	uA
Average Current	$I_{DD(average)}$		-	5	-	uA
Awake Time	$T_{awake}$		-	50	100	us
Period	$T_{period}$		-	25	-	ms
Duty Cycle	D.C.		-	0.2%	-	

### Magnetic Specifications ( @ 25°C room temperature)

Parameter	Symbol	Min.	Typ.	Max.	Unit
Operate Points (Output ON)	BOPS		20	35	G
	BOPN	-35	-20		G
Release Points (Output OFF)	BRPS	5	15		G
	BRPN		-15	-5	G
Hysteresis	BHYS		5		G

# Typical Characteristics

## Typical Application Circuit

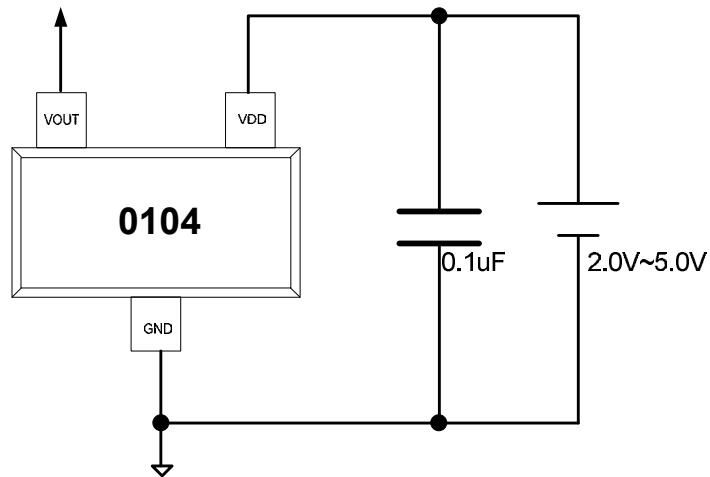

## Waveform

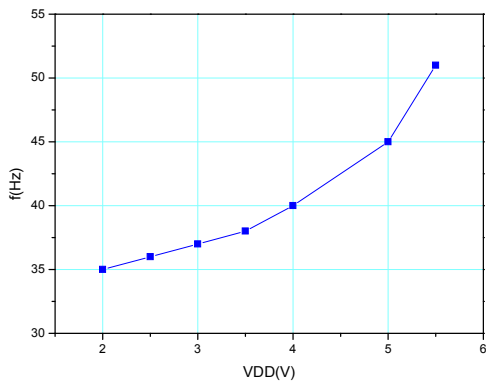

Frequency vs. VDD

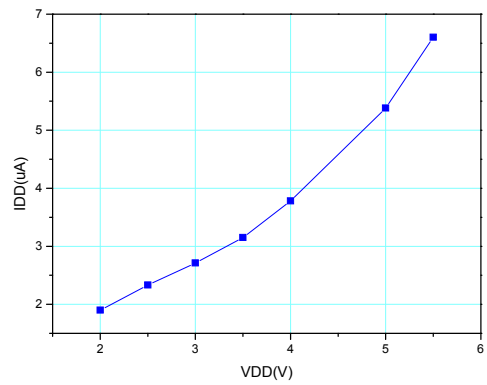

Supply current vs. VDD

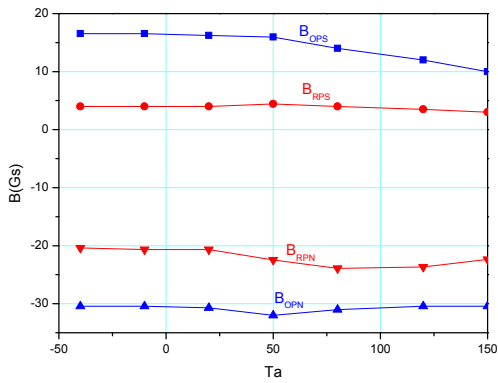

B<sub>OP</sub>&B<sub>RP</sub> vs. T<sub>A</sub>

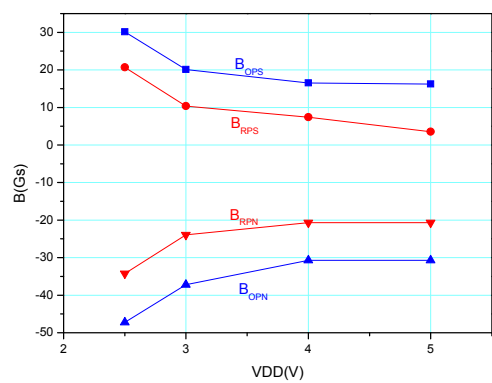

B<sub>OP</sub>&B<sub>RP</sub> vs. VDD

## SOT-23-3L Package Outline Dimensions

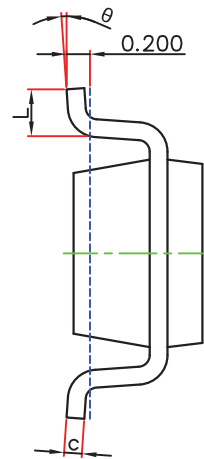
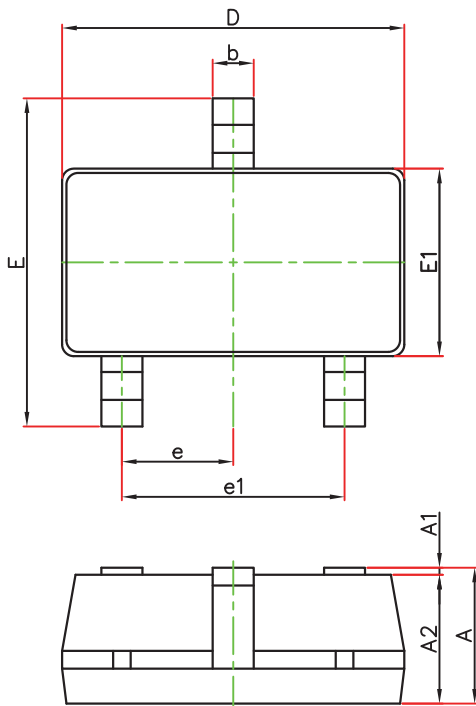

### Hall Location

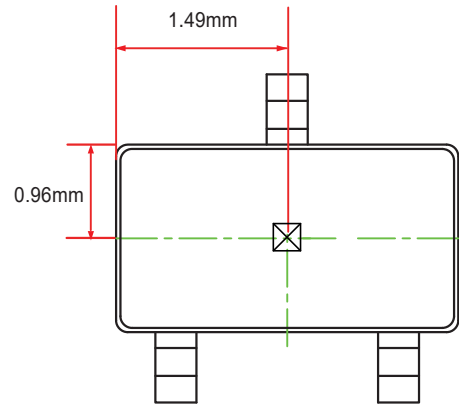

Symbol	Dimensions In Millimeters		Dimensions In Inches	
	Min.	Max.	Min.	Max.
A	1.050	1.250	0.041	0.049
A1	0.000	0.100	0.000	0.004
A2	1.050	1.150	0.041	0.045
b	0.300	0.500	0.012	0.020
c	0.100	0.200	0.004	0.008
D	2.820	3.020	0.111	0.119
E1	1.500	1.700	0.059	0.067
E	2.650	2.950	0.104	0.116
e	0.950(BSC)		0.037(BSC)	
e1	1.800	2.000	0.071	0.079
L	0.300	0.600	0.012	0.024
$\theta$	0°	8°	0°	8°

## SOT-23-3L Suggested Pad Layout

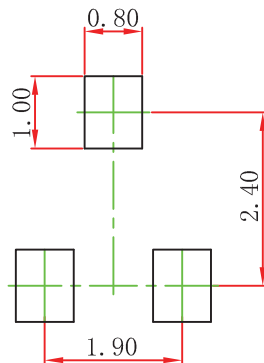

### Note:

1. Controlling dimension: in millimeters.
2. General tolerance:  $\pm 0.05\text{mm}$ .
3. The pad layout is for reference purposes only.

### NOTICE

JSCJ reserve the right to make modifications, enhancements, improvements, corrections or other changes without further notice to any product herein. JSCJ does not assume any liability arising out of the application or use of any product described herein.