



VIS30038

30V N-Channel Power Trench MOSFET

General Description

- Trench Power MOSFET Technology
- Low $R_{DS(ON)}$
- Optimized for High Reliable Switch Application
- High Current Capability
- RoHS and Halogen-Free Compliant

Applications

- Motor Drive
- Load Switch
- Battery Protection
- General DC/DC Converters

Product Summary

V_{DS}		30V
I_D	(at $V_{GS}=10V$)	81A
$R_{DS(ON)}$	(at $V_{GS}=10V$, typ)	3.6m Ω
$R_{DS(ON)}$	(at $V_{GS}=4.5V$, typ)	4.8m Ω

100% UIS Tested

100% RG Tested

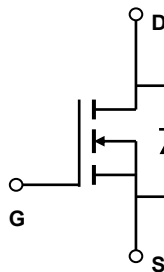

Top View

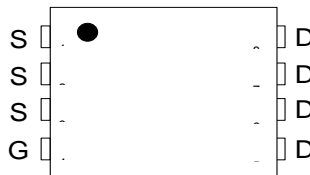

DFN5X6

Bottom View

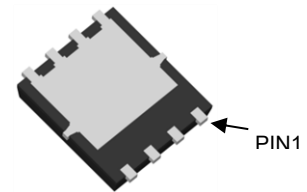

Orderable Part Number

VIS30038

Package Type

DFN5x6

Form

Tape & Reel

Minimum Order Quantity

5000

Absolute Maximum Ratings $T_A=25^\circ C$ unless otherwise noted

Parameter	Symbol	Maximum	Units
Drain-Source Voltage	V_{DS}	30	V
Gate-Source Voltage	V_{GS}	± 20	V
Continuous Drain Current ⁽⁵⁾	I_D	$T_C=25^\circ C$	81
		$T_C=100^\circ C$	51
Pulsed Drain Current ⁽³⁾	I_{DM}	233	A
Continuous Drain Current	I_{DSM}	$T_C=25^\circ C$	32
		$T_A=100^\circ C$	25.6
Avalanche Current ⁽³⁾	I_{AS}	33.3	A
Avalanche Energy $L=0.1mH$ ⁽³⁾	E_{AS}	55	mJ
Power Dissipation ⁽²⁾	P_D	$T_C=25^\circ C$	44.6
		$T_C=100^\circ C$	17.8
Power Dissipation ⁽¹⁾	P_{DSM}	$T_C=25^\circ C$	6.9
		$T_A=100^\circ C$	4.4
Junction and Storage Temperature Range	T_J, T_{STG}	-55 to 150	$^\circ C$

Thermal Characteristics

Parameter	Symbol	Typ	Max	Units
Maximum Junction-to-Ambient ⁽¹⁾	$R_{\theta JA}$	15	18	$^\circ C/W$
Maximum Junction-to-Ambient ^(1,4)		Steady-State	35	42
Maximum Junction-to-Case	$R_{\theta JC}$	2.3	2.8	$^\circ C/W$



VIS30038

30V N-Channel Power Trench MOSFET

Electrical Characteristics (T_J=25°C unless otherwise noted)

Symbol	Parameter	Conditions	Min	Typ	Max	Units
STATIC PARAMETERS						
BV _{DSS}	Drain-Source Breakdown Voltage	I _D =250μA, V _{GS} =0V	30			V
I _{DSS}	Zero Gate Voltage Drain Current	V _{DS} =30V, V _{GS} =0V T _J =55°C			1 5	μA
I _{GSS}	Gate-Body leakage current	V _{DS} =0V, V _{GS} =±20V			±100	nA
V _{GS(th)}	Gate Threshold Voltage	V _{DS} =V _{GS} , I _D =250μA	1.4	1.8	2.2	V
R _{DS(on)}	Static Drain-Source On-Resistance	V _{GS} =10V, I _D =20A T _J =125° V _{GS} =4.5V, I _D =20A		3.6 5.1 4.8	4.3 6.6	mΩ
g _{FS}	Forward Transconductance	V _{DS} =5V, I _D =20A		71		S
V _{SD}	Diode Forward Voltage	I _S =1A, V _{GS} =0V		0.71		V
I _S	Maximum Body-Diode Continuous Current				58	A
DYNAMIC PARAMETERS						
C _{iss}	Input Capacitance	V _{GS} =0V, V _{DS} =15V, f=1MHz		2366		pF
C _{oss}	Output Capacitance			350		pF
C _{rss}	Reverse Transfer Capacitance			225		pF
R _g	Gate resistance	f=1MHz		0.8		Ω
SWITCHING PARAMETERS						
Q _g (10V)	Total Gate Charge	V _{GS} =10V, V _{DS} =15V, I _D =20A		45.5		nC
Q _g (4.5V)	Total Gate Charge			21.6		nC
Q _{gs}	Gate Source Charge			9.7		nC
Q _{gd}	Gate Drain Charge			9.4		nC
t _{D(on)}	Turn-On Delay Time	V _{GS} =10V, V _{DS} =15V, R _L =0.75Ω, R _{GEN} =3Ω		12.3		ns
t _r	Turn-On Rise Time			9.4		ns
t _{D(off)}	Turn-Off Delay Time			28.5		ns
t _f	Turn-Off Fall Time			9.8		ns
t _{rr}	Body Diode Reverse Recovery Time	I _F =20A, di/dt=200A/μs		6.8		ns
Q _{rr}	Body Diode Reverse Recovery Charge	I _F =20A, di/dt=200A/μs		10.2		nC

- 1) R_{θJA} is measured with the device mounted on 1in² FR-4 board with 2oz. Copper, in a still air environment with T_A=25°C. The Power dissipation P_{DSM} is based on R_{θJA} ≤ 10s and the maximum allowed junction temperature of 150°C. The value in any given application depends on the user's specific board design.
- 2) The power dissipation P_D is based on T_{J(MAX)}=150°C, using junction-to-case thermal resistance, and is more useful in setting the upper dissipation limit for cases where additional heatsinking is used.
- 3) Single pulse width limited by junction temperature T_{J(MAX)}=150°C.
- 4) R_{θJA} is the sum of the thermal impedance from junction to case R_{θJC} and case to ambient.
- 5) The maximum current rating is package limited.

TYPICAL ELECTRICAL AND THERMAL CHARACTERISTICS

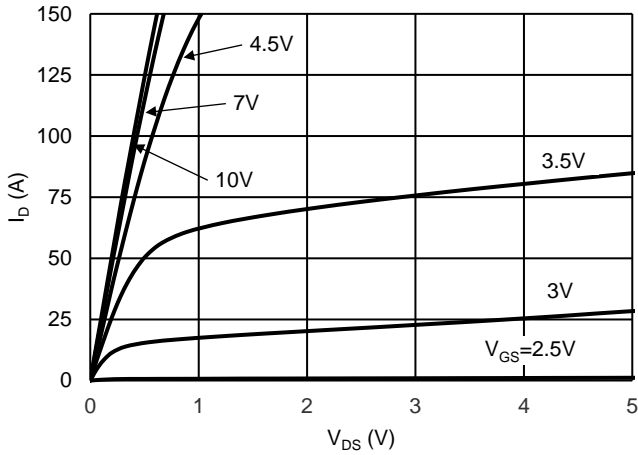

Fig 1. Typical Output Characteristics

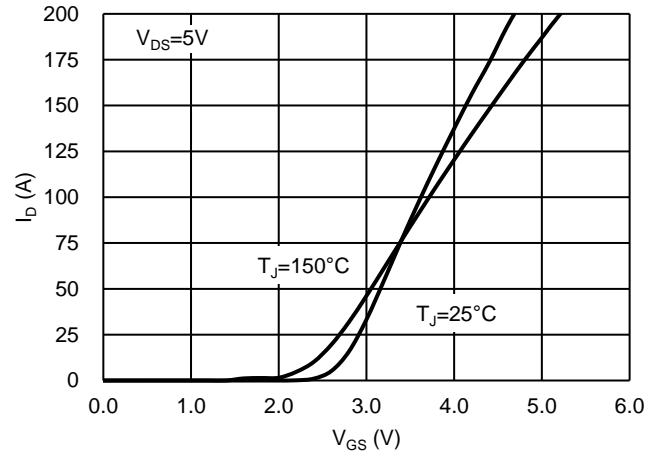

Fig 2. Typical Transfer Characteristics

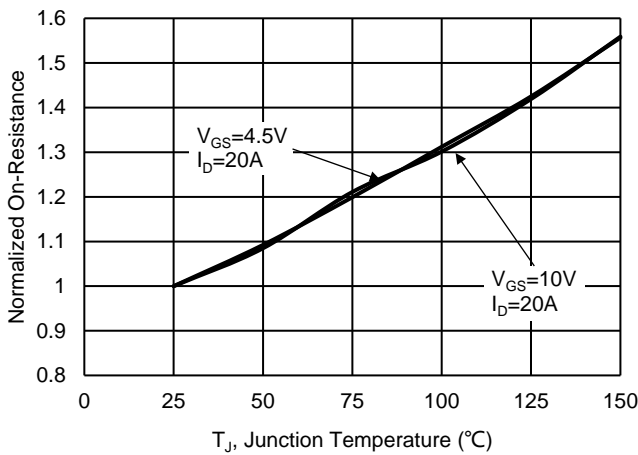

Fig 3. Normalized On-Resistance vs. Temperature

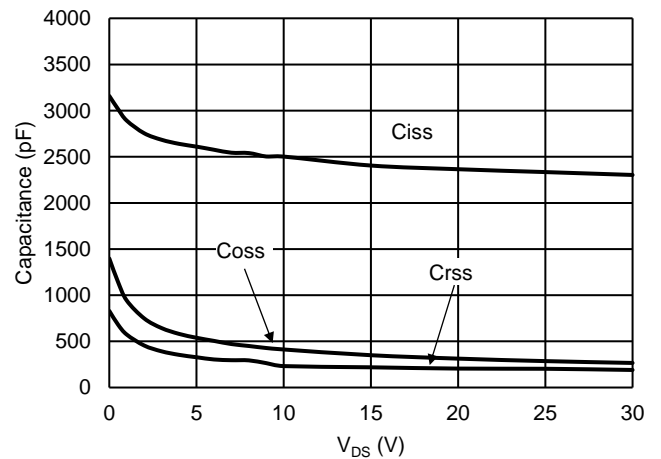

Fig 4. Typical Capacitance vs. V_{DS}

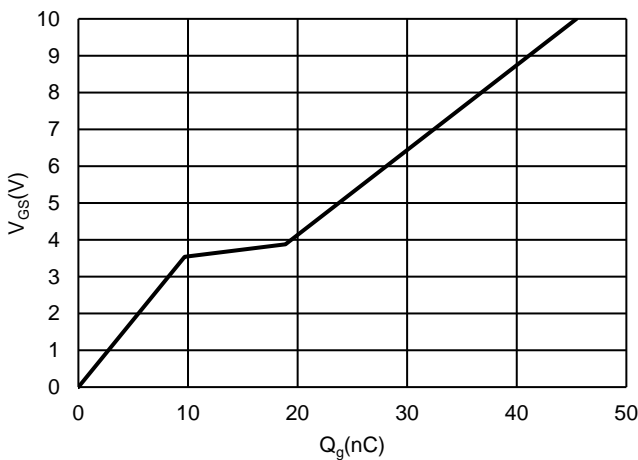

Fig 5. Typical Gate Charge vs. V_{GS}

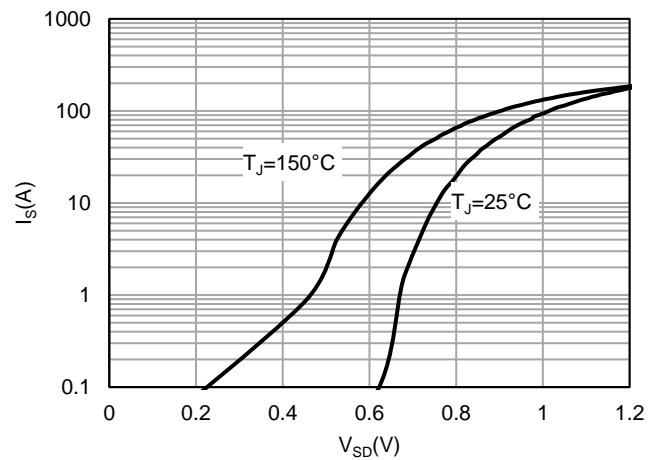

Fig 6. Typical Source-Drain Diode Forward Voltage

TYPICAL ELECTRICAL AND THERMAL CHARACTERISTICS

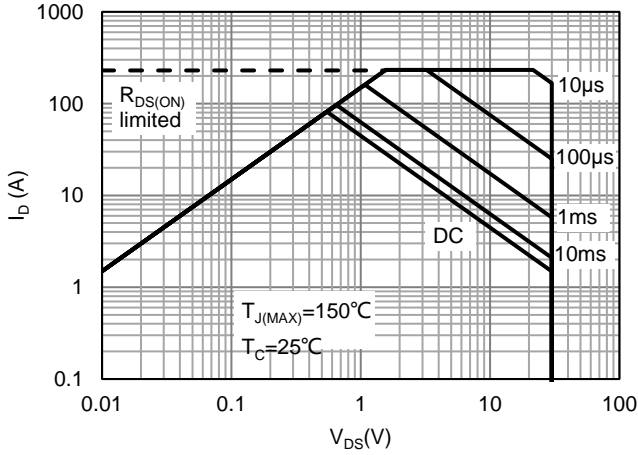

Fig 7. Maximum Safe Operating Area

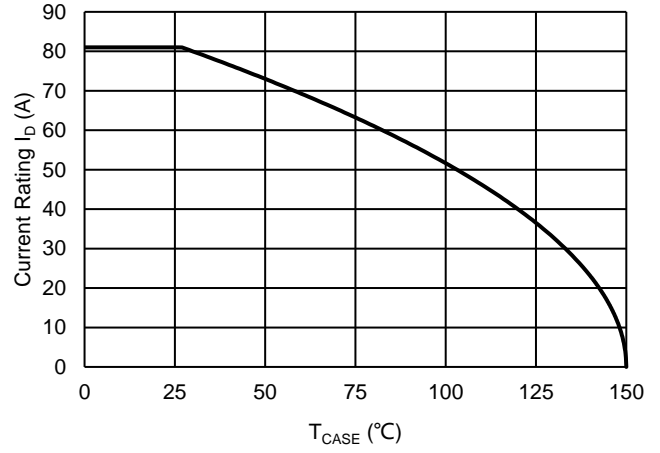

Fig 8. Maximum Drain Current vs. Case Temperature

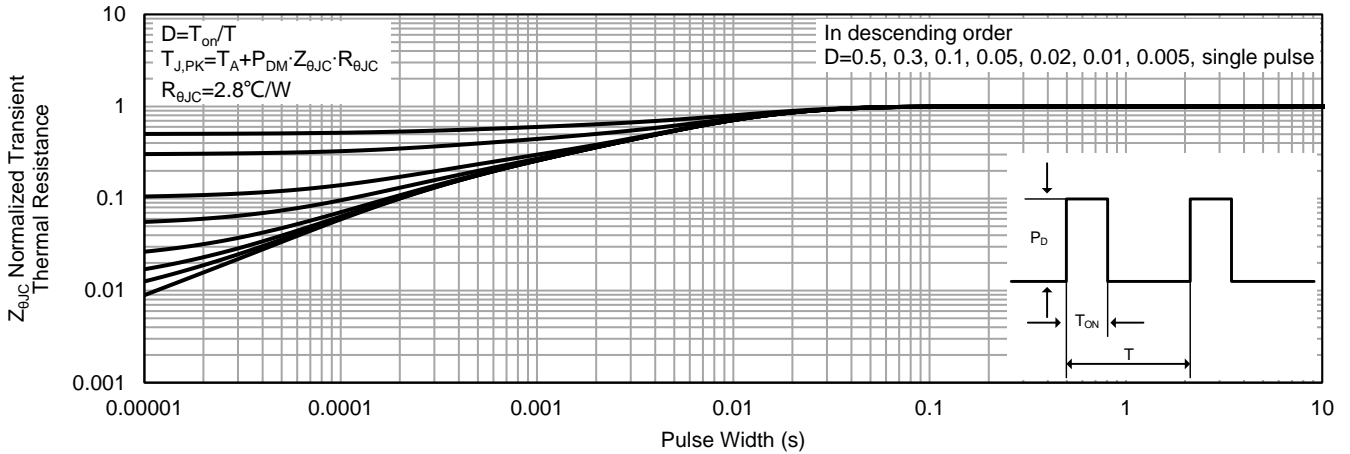

Fig 9. Normalized Maximum Transient Thermal Impedance, Junction-to-Case

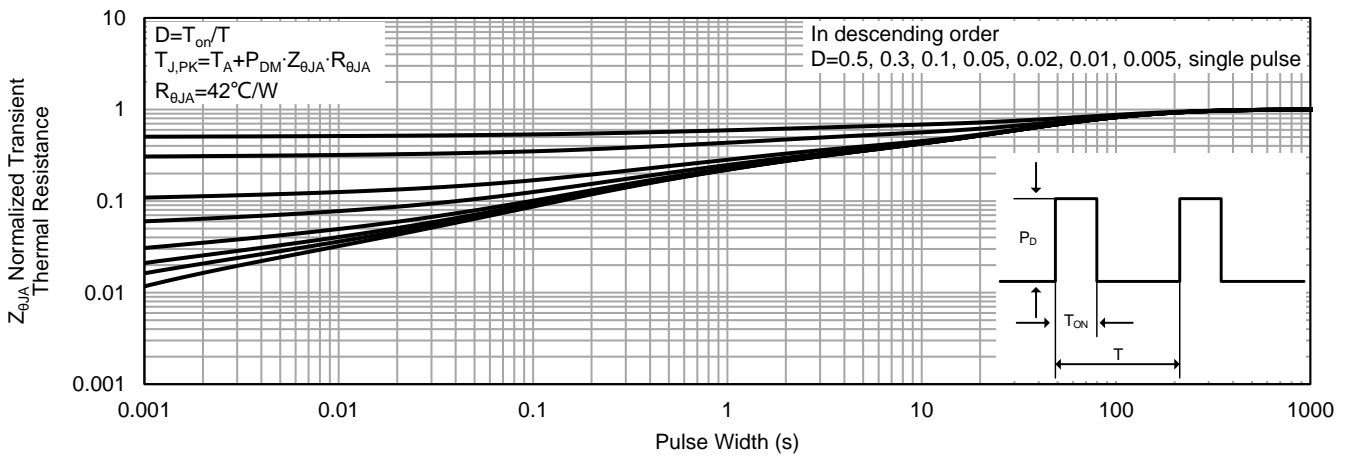

Fig 10. Normalized Maximum Transient Thermal Impedance, Junction-to-Ambient



VIS30038

30V N-Channel Power Trench MOSFET

TYPICAL ELECTRICAL AND THERMAL CHARACTERISTICS

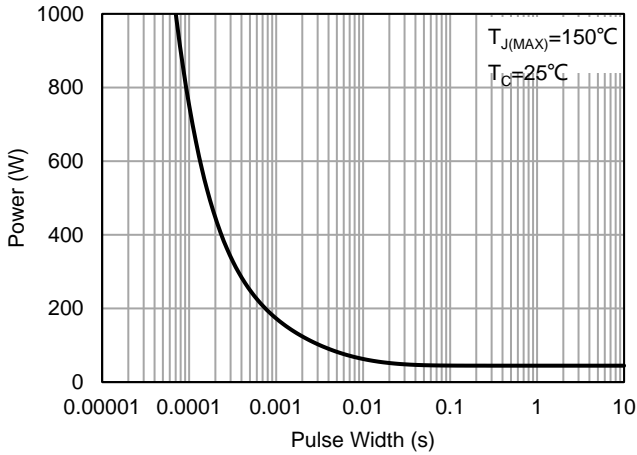

Fig 11. Single Pulse Power Rating Junction-to-Case

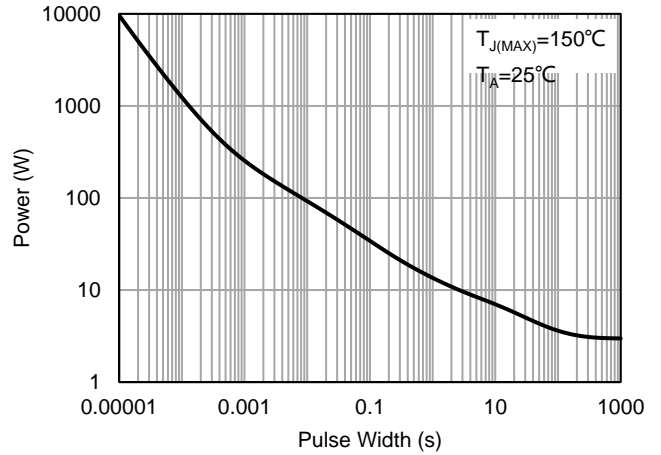

Fig 12. Single Pulse Power Rating Junction-to-Ambient

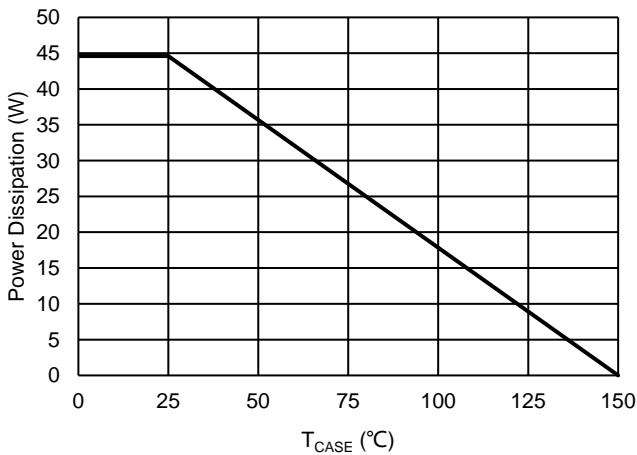

Fig 13. Maximum Power Rating vs. Temperature

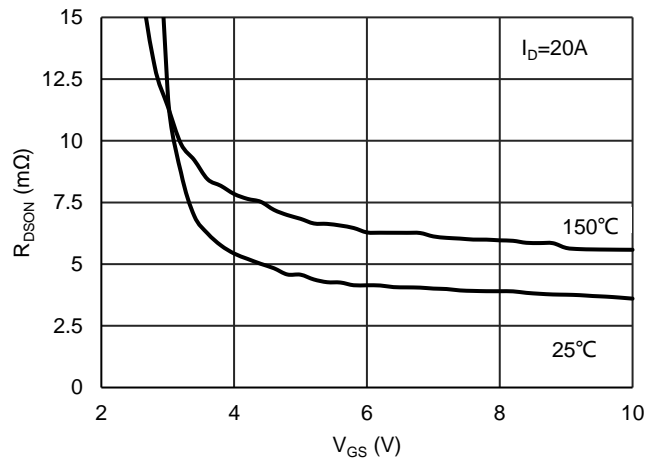

Fig 14. On-Resistance vs. V_{GS}

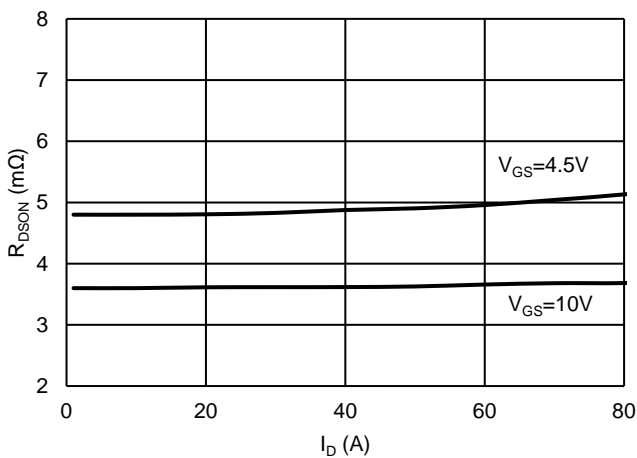

Fig 15. On-Resistance vs. Drain Current

TEST CIRCUIT

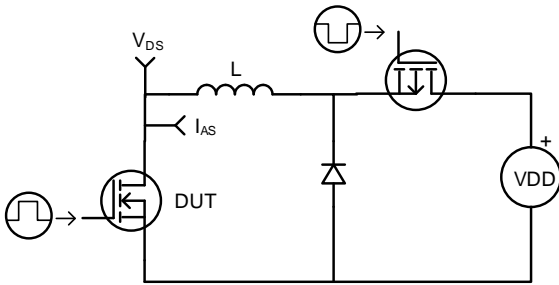

Fig16. Unclamped Inductive Test Circuit

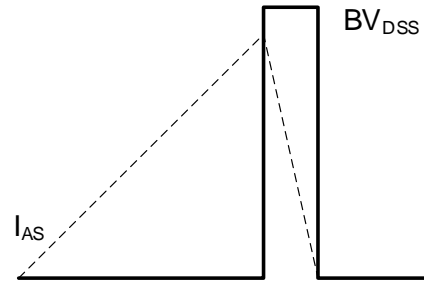

Fig17. Unclamped Inductive Waveform

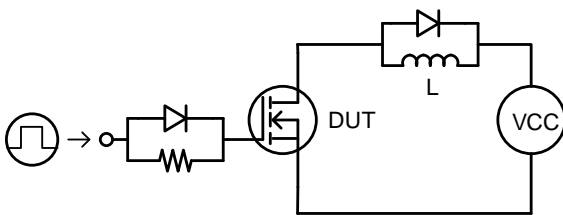

Fig18. Q_g Test Circuit

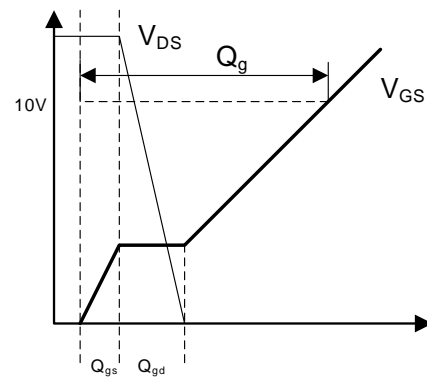

Fig19. Q_g Waveform

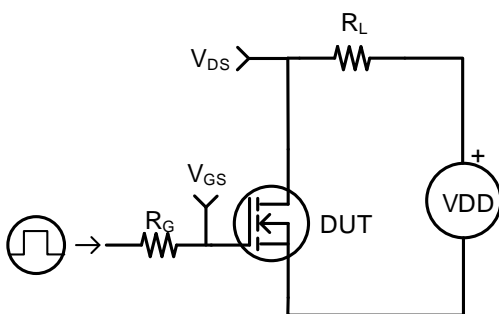

Fig18. Resistive Switching Test Circuit

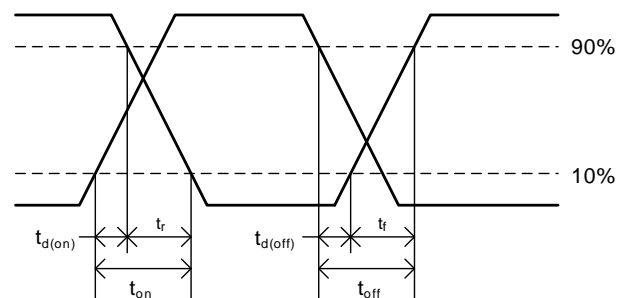

Fig19. Switching Time Waveform

TEST CIRCUIT

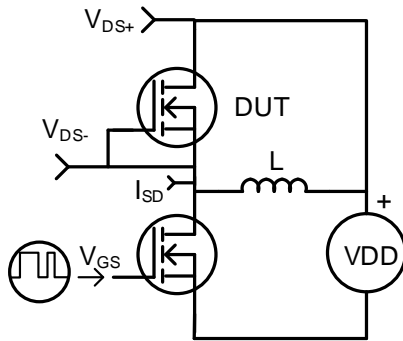

Fig20. Diode Recovery Test Circuit

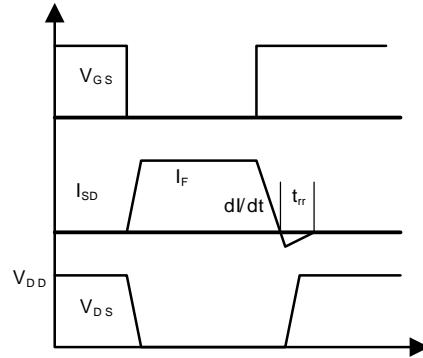
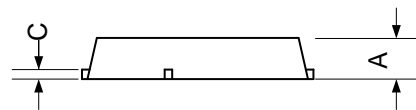
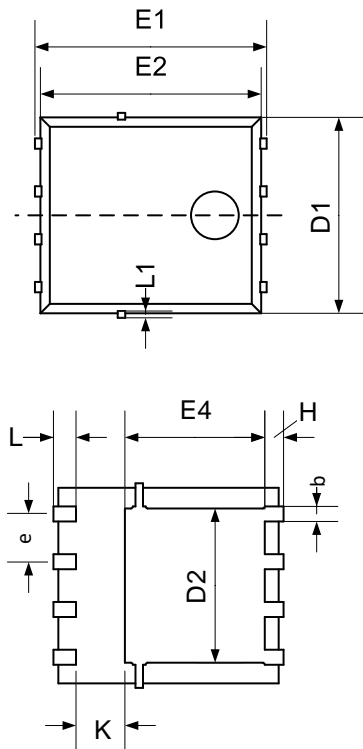

Fig21. Diode Recovery Test Waveform

DFN5x6 OUTLINE



SYMBOL	DIM	MILLIMETERS	
		MIN [mm]	MAX [mm]
A		0.900	1.000
b		0.350	0.450
C		0.254 REF	
D1		4.824	4.976
D2		3.910	4.110
e		1.270 TYP	
E1		5.974	6.126
E2		5.674	5.826
E4		3.375	3.575
H		0.574	0.726
K		1.190	1.390
L		0.559	0.711
L1		0	0.120