

DESCRIPTION

The SS8847T is a dual bridge motor driver which has two H-bridge drivers, and can drive two DC brush motors, a bipolar stepper motor, solenoids, or other inductive loads.

It operates from 2.7V to 16V, and can deliver load current up to 1.0A per channel. The output driver block of each H-bridge consists of P+N-channel power MOSFETS configured as an H-bridge to drive the motor windings. Each H-bridge includes circuitry to regulate or limit the winding current.

The internal safety features include sinking and sourcing current limits implemented with external sensors, under-voltage lockout, over current protection (OCP) and thermal shutdown. An over-temperature output flag is available to indicate thermal shutdown.

The SS8847T is packaged in 16-pin, 5.0mm×6.4mm eTSSOP with an exposed thermal pad on the back.

FEATURES

- Wide Power Supply Voltage Range: 2.7V to 16V
- Two Internal Full-Bridge Drivers
- Low Quiescent Current: 1.1mA
- Low Sleep Current: 1 μ A
- Thermal Shutdown and Under-Voltage Lockout Protection
- Over Current Protection (OCP)
- Over-Temperature Output Flag
- Thermally-Enhanced Surface-Mount Package
- Low MOSFET On Resistance (HS: 650m Ω ; LS: 350 m Ω)

APPLICATIONS

- POS Printers
- Washers, dryers and dishwashers
- Stage lighting equipment
- Refrigerator damper and ice maker

BLOCK DIAGRAM

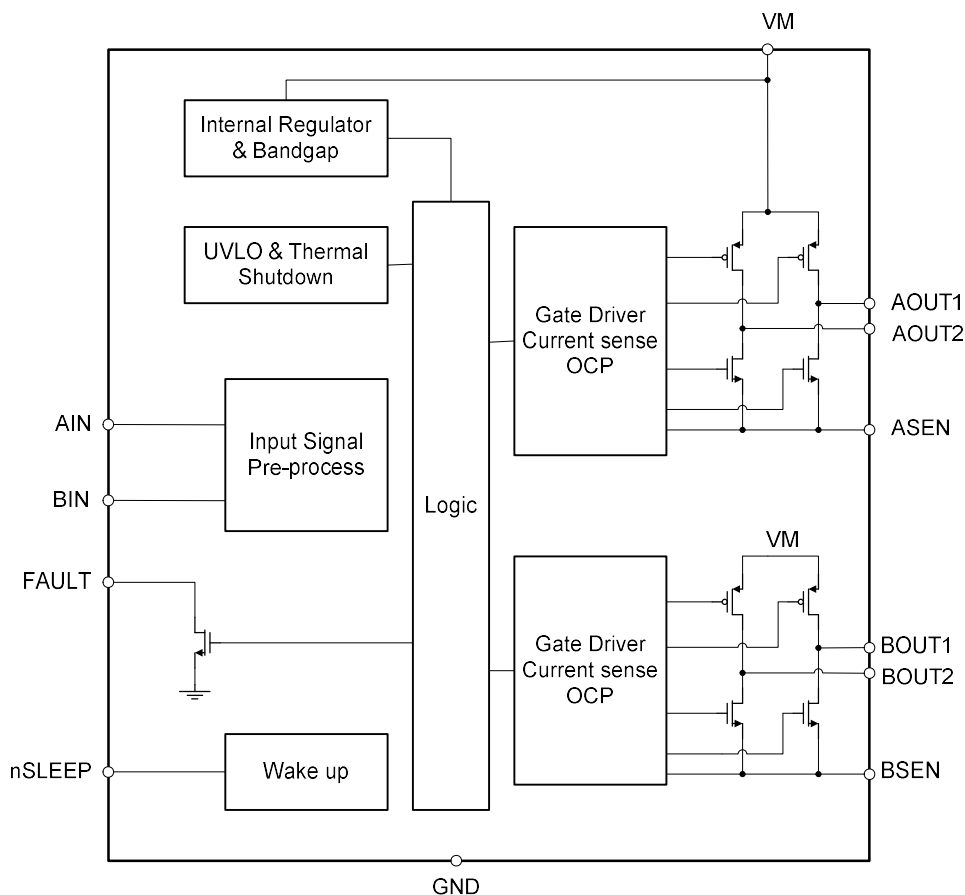

APPLICATION CIRCUIT

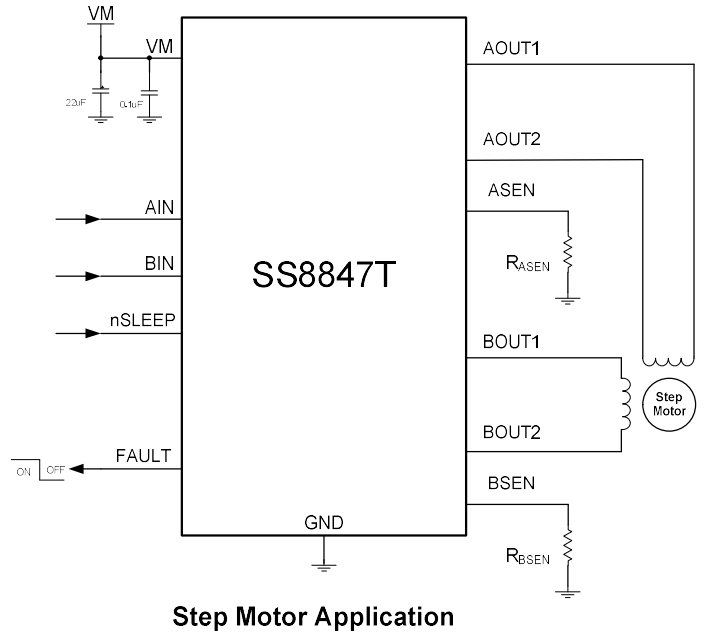
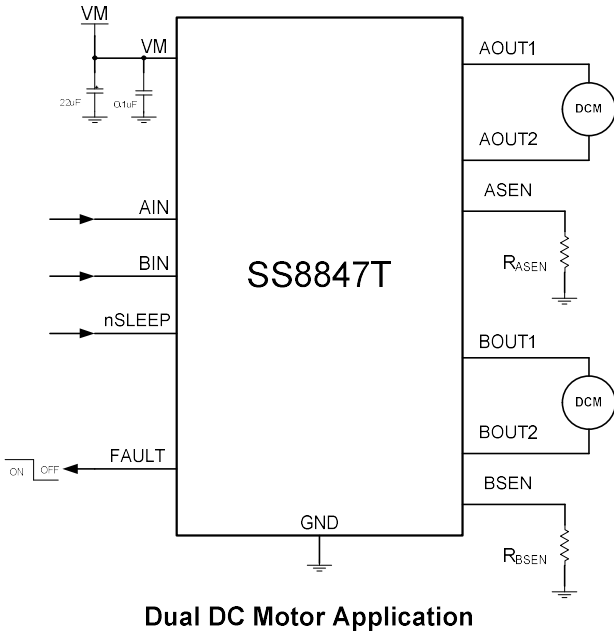

ORDER INFORMATION

Valid Part Number	Package Type	Top Code
SS8847T-ET-TP	16-Pin, ETSSOP	SS8847T-ET

PIN CONFIGURATION

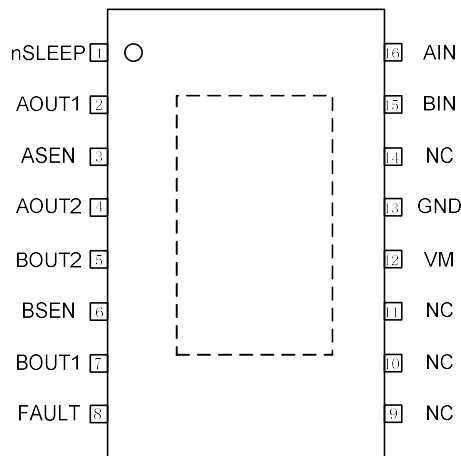

Note: The exposed pad for eTSSOP16 package need to be connected to GND.

PIN DESCRIPTION

Pin Name	I/O	Description	Pin No.
			TSSOP-16
nSLEEP	I	Sleep mode input. Set this pin to logic high to enable the device. Set this pin to logic low to go to low-power sleep mode	1
AOUT1	O	Connect to motor winding A.	2
ASEN	I/O	Channel A current sense. Connect to current sensor resistor for Channel A	3
AOUT2	O	Connect to motor winding A.	4
BOUT2	O	Connect to motor winding B.	5
BSEN	I/O	Channel B current sense. Connect to current sensor resistor for Channel B	6
BOUT1	O	Connect to motor winding B.	7
FAULT	OD	Fault output. Logic low when in over-temperature fault condition.	8
VM	Power	Device power supply. Ranges from 2.7V to 18V. A 10- μ F ceramic bypass capacitor to GND is recommended.	12
GND	GND	Device ground. (Both the GND pin and device Power PAD must be connected to ground.)	13
BIN	I	B channel input terminal to control current direction of bridge B. (220K internal pull down resistor to GND.)	15
AIN	I	A channel input terminal to control current direction of bridge A. (220K internal pull down resistor to GND.)	16
NC	-	No connect	9,10,11,14

OPERATION DESCRIPTION

The SS8847T device is an integrated motor driver solution for brushed DC or bipolar stepper motors. The device integrates PMOS+NMOS H-bridges and current regulation circuitry. The SS8847T can be powered with a supply voltage from 2.7 to 16V and can provide an output current up to 1.0A.

The motor output current can be either controlled by an external pulse width modulator (PWM) or internal PWM current controller. The current regulation (internal PWM current control) is a fixed off time PWM slow decay.

The SS8847T includes a lower power sleep mode, which lets the system save power when not driving the motor. It also provides the fault protections include: under-voltage lockout (UVLO) and over-temperature protection (OTP).

EXTERNAL PWM CURRENT CONTROL

The motor current can be regulated by applying external PWM signals on the input pins AIN and BIN. The AIN input pin control the state of the AOUT1 and AOUT2; similarly, the BIN input pin control the state of the BOUT1 and BOUT2. Table 1 shows the logic.

Table 1 Logic

nSLEEP	*IN	*OUT1	*OUT2	Output state
L	X	Z	Z	Standby
H	L	L	H	Reverse
H	H	H	L	Forward

In external PWM control mode, the winding's inductive current ramps up when the high-side MOSFET is on and freewheels during the high side MOSFET's off time to cause the recirculation current.

To handle this recirculation current, the H-bridge can operate in fast decay mode, it is shown in below figure for forward operation and reverse operation.

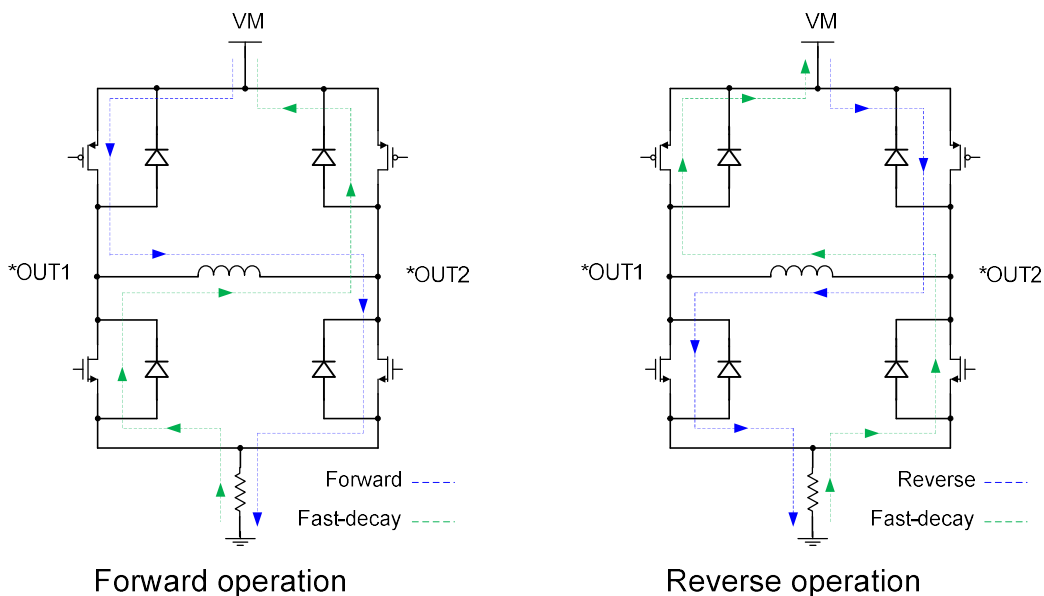

INTERNAL PWM CURRENT CONTROL

An internal constant off-time PWM current control circuit will regulate the motor current as the following: When an H-bridge is enabled, current rises through the winding at a rate dependent on the DC voltage and inductance of the winding. The current increases in the motor winding, which is sensed by an external sense resistor (RSENSE). During the initial blanking time TBLANK (1.8µs), the high-side MOSFET always turns on in spite of current limit detection. This blanking time also sets the minimum on time of the PWM when operating in current chopping mode.

After the blanking time, if the voltage across RSENSE reaches the internal reference voltage threshold VTRIP (200mV), the bridge disables the current by shuts off the high-side MOSFET. After that, the H-bridge switches to slow decay mode. Winding current is decreases and recirculated by enabling both of the low-side FETs in the bridge. In this slow decay mode, the current freewheels through one low-side MOSFET and the body diode of the other low-side MOSFET to short the winding. This mode enables both two low-side MOSFETs, which feature a lower voltage drop and lower power dissipation during decay operation.

The slow decay mode is held until the internal clock reaches it's constant off time (typically 21µs). After the fixed off time the high-side MOSFET is enable and the winding current will increase again. The cycle then repeats.

Calculate the current limit as:
$$I_{LIMIT} = \frac{V_{trip}}{R_{sense}}$$

Example: If a 1-Ω sense resistor is used, the chopping current will be 200 mV/1 Ω = 200 mA. If current control is not needed, the xSEN pins should be connected directly to ground.

SLEEP MODE

Driving nSLEEP low will put the device into a low power sleep state. In this state, the H-bridges are disabled, all internal logic is reset, and all internal clocks are stopped. All inputs are ignored until n SLEEP returns inactive high. When returning from sleep mode, sometime (up to 140 us) needs to pass before the motor driver becomes fully operational.

BLANKING TIME

An internal blanking time T_{BLANK} blanks the output of the current sense comparator when the outputs are switched, which is also the minimum on time for high-side MOSFET. There is usually a current spike during the switching transition due to the body diode's reverse-recovery current or the distributed inductance or capacitance. This blanking time is filtering the current spike and prevents it from erroneously shutting down the high-side MOSFET.

OVER CURRENT PROTECTION (OCP)

An analog current limit circuit on each FET limits the current through the FET by limiting the gate drive. If this analog current limit persists for longer than the OCP deglitch time (1.4 μ s), all FETs in the H-bridge will be disabled and the FAULT pin will be driven low. The driver will be re-enabled after the OCP retry period (t_{OCP}) has passed. FAULT becomes high again at this time. If the fault condition is still present, the cycle repeats. If the fault is no longer present, normal operation resumes and FAULT remains de-asserted. Please note that only the H-bridge in which the OCP is detected will be disabled while the other bridge will function normally.

Over current conditions are detected independently on both high- and low-side devices; that is, a short to ground, supply, or across the motor winding will all result in an over current shutdown. Over current protection does not use the current sense circuitry used for PWM current control, so it functions even without presence of the xSEN resistors.

THERMAL SHUTDOWN (TSD)

If the die temperature exceeds safe limits (typically 170°C), all FETs in the H-bridge will be disabled and the FAULT pin will be driven low. Once the die temperature has fallen to a safe level (typically 125°C), operation will automatically resume.

UNDERVOLTAGE LOCKOUT (UVLO)

If at any time the voltage on the VM pin falls below the under voltage lockout threshold voltage, all circuitry in the device will be disabled, and all internal logic will be reset. Operation will resume when VM rises above the UVLO threshold. FAULT is driven low in the event of an under voltage condition.

POWER SUPPLY AND LAYOUT GUIDE

The inductance between the power supply and the motor drive system limits the rate current can change from the power supply. If the local bulk capacitance is too small, the system responds to excessive current demands or dumps from the motor with a change in voltage. When adequate bulk capacitance is used, the motor voltage remains stable and high current can be quickly supplied. The datasheet generally provides a recommended value, but system-level testing is required to determine the appropriate sized bulk capacitor. The voltage rating for bulk capacitors should be higher than the operating voltage, to provide margin for cases when the motor transfers energy to the supply.

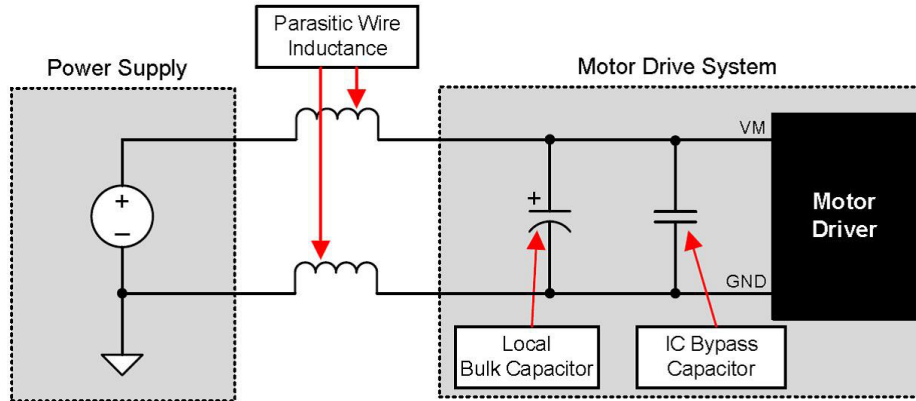

Example Setup of Motor Drive System with External Power Supply

The VM pin should be bypassed to GND using low-ESR ceramic bypass capacitors with a recommended value of 22- μF rated for VM. This capacitor should be placed as close to the VM pin as possible with a thick trace or ground plane connection to the device GND pin.

The printed circuit board (PCB) should use a heavy ground-plane. The SS8847T must be soldered directly onto the board for better electrical and thermal performance. The sense resistors should be placed as close as possible to the part for accurate current detection. The SS8847T uses an exposed pad, which provides a path for enhanced thermal dissipation. The thermal pad should be soldered directly to copper on the PCB. Thermal vias are often used to transfer heat to other layers of the PCB.

DESIGN EXAMPLE

Below is a design example following the application guidelines for the specifications:
 The detailed application schematic is shown below Figure. The typical performance and circuit waveforms have been shown in the Typical Performance Characteristics section.

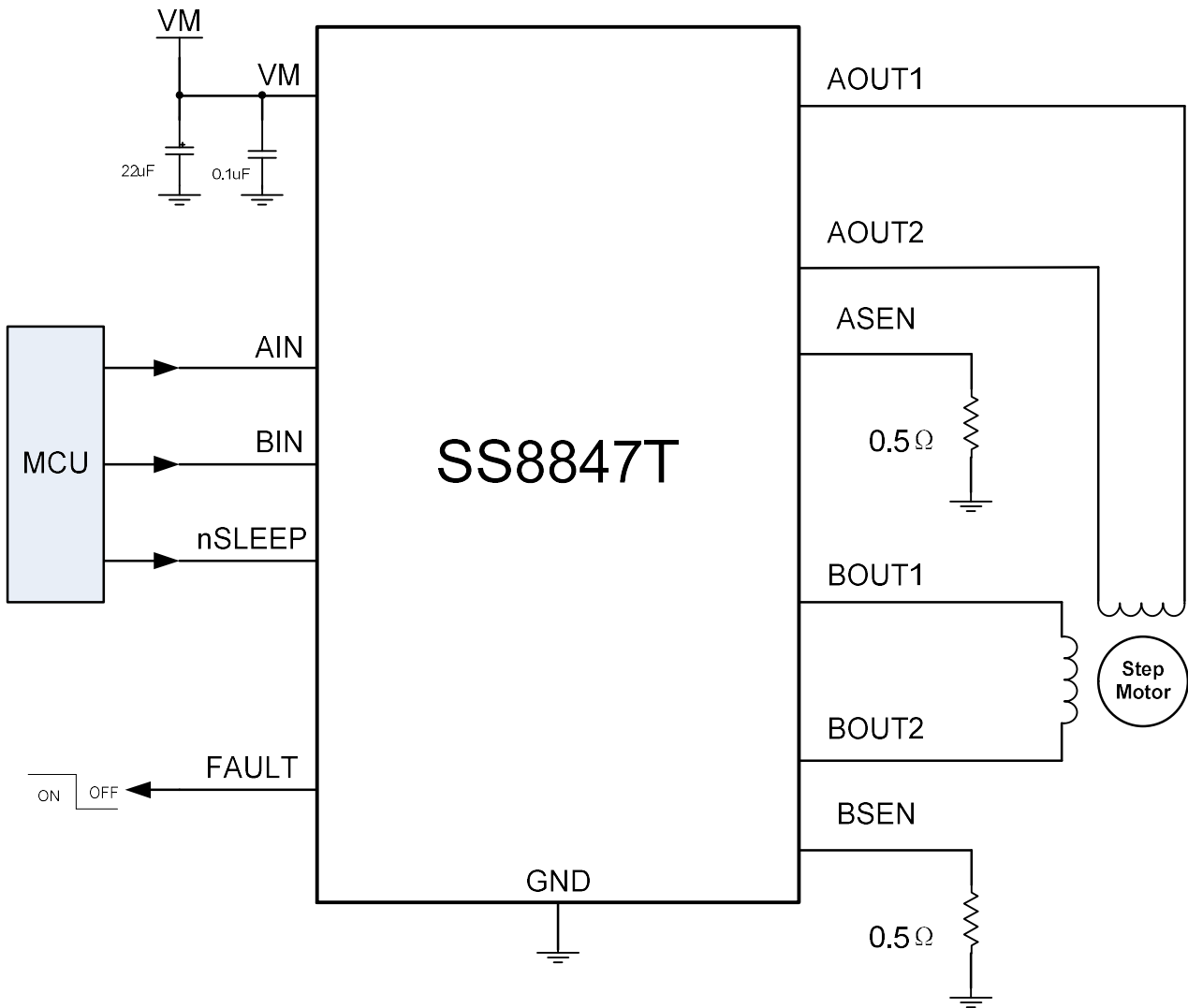

Detailed Application Schematic

ABSOLUTE MAXIMUM RATING

Parameter	Symbol	Rating	Unit
Power Supply Voltage	V_{IN}	-0.3 ~ +18	V
AOUTx Voltage	V_{AOUTx}	-0.3 ~ $+V_{IN}+1V$	V
BOUTx Voltage	V_{BOUTx}	-0.3 ~ $+V_{IN}+1V$	V
Sense Voltage	V_{SENx}	-0.3 ~ +0.5	V
All Other Pins	-	-0.3 ~ +6.5	V
Junction Temperature	T_J	150	°C
Operating Temperature	T_{OPR}	-40 ~ +85	°C
Storage Temperature	T_{STG}	-40 ~ +150	°C

Note: Absolute maximum ratings are those values beyond which the device could be permanently damaged.

RECOMMENDED OPERATING CONDITIONS

Parameter	Symbol	Rating			Unit
		Min.	Typ.	Max.	
Supply Voltage	V_{IN}	2.7	-	16	V
Output Current	$I_{A/BOUx}$	-	1.0	-	A
Operating Junction Temperature	T_J	-40	50	125	°C

THERMALRESISTANCE

Parameter	θ_{JA}	θ_{JC}	Unit
TSSOP 16-EP (5.0x6.4mm)	45	10	°C/W

Note: Measure on JESD51-7, 4-layer PCB

ELECTRICAL CHARACTERISTICS

Nominal conditions: VM=12V, Ta=+25°C

Parameter	Symbol	Conditions	Min.	Typ.	Max.	Unit
Power Supply						
Input Supply Voltage	V _{IN}	-	2.7	-	16	V
Quiescent Current	I _{IN}	nSLEEP=3.3V, no load	-	1.1	2	mA
	I _{IN_SLEEP}	nSLEEP=0V, no load	-	-	1	μA
Integrated MOSFETs						
Body-Diode Forward Voltage	V _F	I _{OUT} =500mA	-	-	1	V
Output On Resistance	R _{HS}	I _{OUT} =500mA, V _{IN} =5V T _J =25°C	-	650	-	mΩ
		I _{OUT} =500mA, V _{IN} =5V T _J =85°C	-	850	-	mΩ
	R _{LS}	I _{OUT} =500mA, V _{IN} =5V T _J =25°C	-	350	-	mΩ
		I _{OUT} =500mA, V _{IN} =5V T _J =85°C	-	460	-	mΩ
Control Logic						
UVLO Threshold (Rising)	V _{IN_RISE}	-	-	-	2.7	V
UVLO Hysteresis	V _{HYS}	-	-	100	-	mV
Input Logic 'Low' Threshold	V _{IL}	-	-	-	0.6	V
Input Logic 'High' Threshold	V _{IH}	-	2	-	-	V
nSLEEP Logic, Low	V _{SLEEP_L}	-	-	-	0.4	V
nSLEEP Logic, High	V _{SLEEP_H}	-	2	-	-	V
Input pull down resistance	R _{PD}	nSLEEP and Logic input pin	-	220	-	kΩ
Fault Output Logic, Low	V _{FAULT_L}	Flag triggered by OTP 1mA Current	-	-	500	mV
Fault Output Leakage Current	I _{LEAK_FAULT}	V _{FAULT} =5V	-	-	1	μA
Constant Off Time	T _{OFF}	-	-	21	-	μs
Cross Over Delay	T _{CROSS}	HS off to LS on or LS off to HS on for one bridge arm	100	250	500	ns
Sleep Mode Wakeup Time	T _{WAKE}	Sleep inactive high to full bridge turn on	-	140	-	us
Protection Circuitry						
Current Limit Sense Trip Voltage	V _{TRIP}	-	-	200	-	mV

Parameter	Symbol	Conditions	Min.	Typ.	Max.	Unit
Blanking Time	T_{BLANK}	-	1.2	1.8	2.4	μs
Over current protection trip level	I_{OCP}		-	1.75	-	A
Over current protection period	T_{OCP}	-	-	1.6	-	ms
Thermal Shutdown	TSD	-	-	170	-	$^{\circ}C$
Thermal Shutdown Hysteresis	-	-	-	45	-	$^{\circ}C$

TYPICAL CHARACTERISTICS

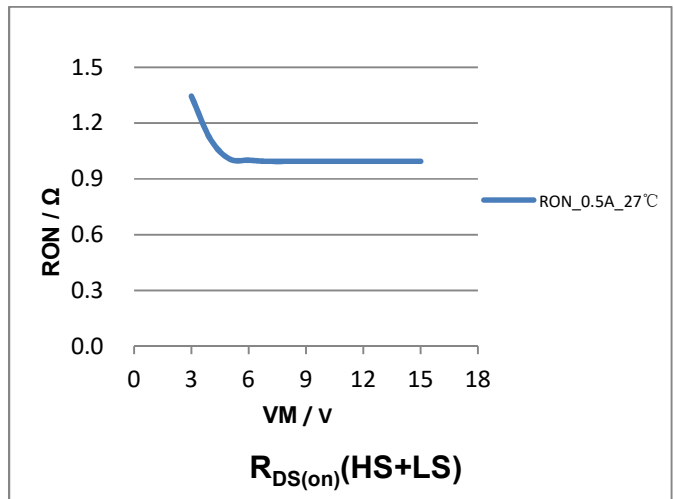
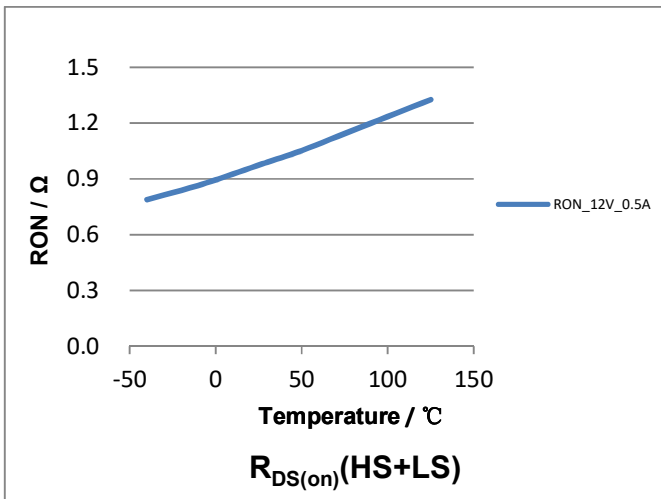
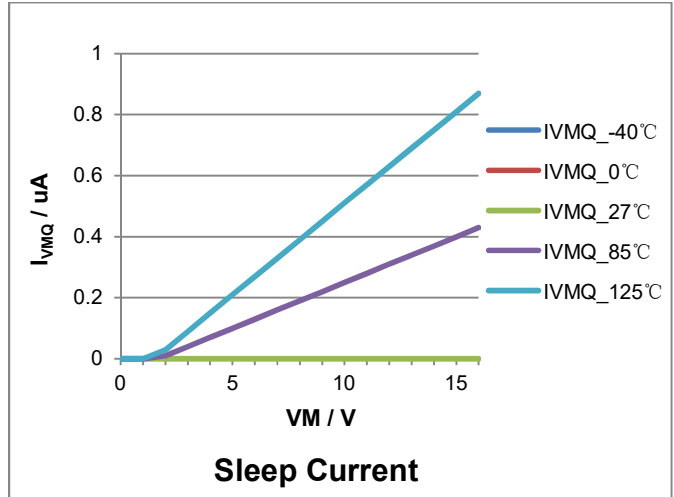
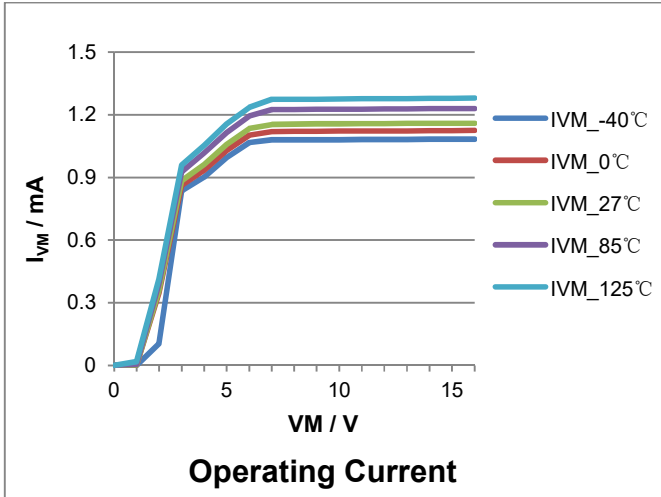

PACKAGE INFORMATION

16 Pins, (e)TSSOP

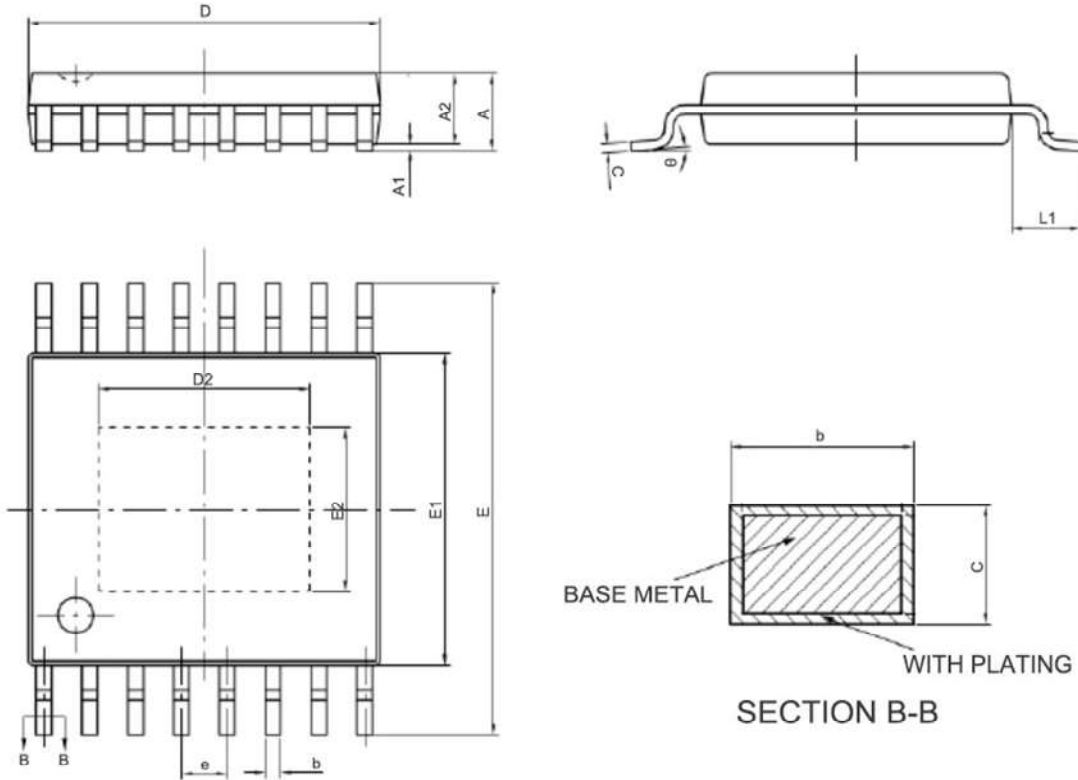

Symbol	Dimensions		
	Min.	Nom.	Max.
A	-	-	1.20
A1	0.05	-	0.15
A2	0.90	1.00	1.05
b	0.20	-	0.30
e	0.65 BSC		
c	0.13	-	0.19
D	4.86	4.96	5.06
D2	2.90	3.00	3.10
E	6.20	6.40	6.60
E1	4.30	4.40	4.50
E2	2.20	2.30	2.40
L1	1.00 REF		
θ	0	-	8

Notes:

1. Refer to JEDEC MO-153
2. Unit: mm

IMPORTANT NOTICE

Shenzhen LeadPower Semiconductor CO.,LTD reserves the right to make corrections, modifications, enhancements, improvements, and other changes to its products and to discontinue any product without notice at any time.

LPS cannot assume responsibility for use of any circuitry other than circuitry entirely embodied in a LPS product. No circuit patent licenses are implied.

Shenzhen LeadPower Semiconductor CO.,LTD