



## MBR30L100CTF Schottky barrier rectifiers Low I<sub>R</sub> at High Temperature

### Features

- Construction utilizes void-free molded plastic technique
- Low reverse leakage
- High forward surge current capability
- High temperature soldering guaranteed:  
250°C/10 seconds
- Component in accordance RoHS 2011/65/EU



TO-220AB/CT

TO-220F/CT

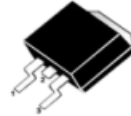

TO-263/DC

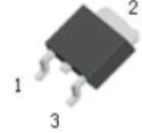

TO-252/CS



RoHS  
COMPLIANT

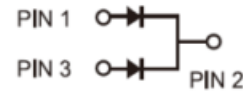

### Mechanical Data

Case: TO-220AB/F

Molding compound meets

UL 94 V-0 flammability rating

- **Terminals:** Solder plated, solderable per MIL-STD-750, Method 2026
- **Polarity:** As marked
- **Mounting Position:** Any

### Major Ratings and Characteristics

I <sub>F(AV)</sub>	30A
V <sub>RRM</sub>	20 V to 200 V
I <sub>FSM</sub>	200A
V <sub>F</sub>	0.40V, 0.45V, 0.55V, 0.65V, 0.75V
T <sub>Jmax.</sub>	125°C, 150°C

### Maximum Ratings & Electrical Characteristics (T<sub>A</sub> = 25 °C unless otherwise noted)

Items	Symbol	MBR 30L20	MBR 30L40	MBR 30L45	MBR 30L60	MBR 30L100	MBR 30L150	MBR 30L200	Unit
Maximum repetitive peak reverse voltage	V <sub>RRM</sub>	20	40	45	60	100	150	200	V
Maximum RMS voltage	V <sub>RMS</sub>	14	28	31.5	42	70	105	140	V
Maximum DC blocking voltage	V <sub>DC</sub>	20	40	45	60	100	150	200	V
Average forward rectified current (See Fig.1)	I <sub>F(AV)</sub>	30.0							A
Peak forward surge current 8.3 ms single half sine-wave superimposed on rated load	I <sub>FSM</sub>	200.0							A
Thermal resistance from junction to case	R <sub>θJc</sub>	2.0							°C/W
Operating junction and storage temperature range	T <sub>J</sub> , T <sub>STG</sub>	-55 to +125				-55 to +150			°C
Maximum instantaneous forward voltage at 15.0A	V <sub>F</sub>	0.40	0.45	0.55	0.65	0.75		V	
Typical junction capacitance <sup>(1)</sup>	C <sub>J</sub>	800				350			pF
Maximum DC reverse current at rated DC blocking voltage	T <sub>A</sub> =25°C	0.15				0.1			mA
	T <sub>A</sub> =100°C	40.0				20.0			

Note: 1. Measured at 1MHz and applied reverse voltage of 4.0V D.C.



### Typical Performance Characteristics

Figure 1. Forward Current Characteristics

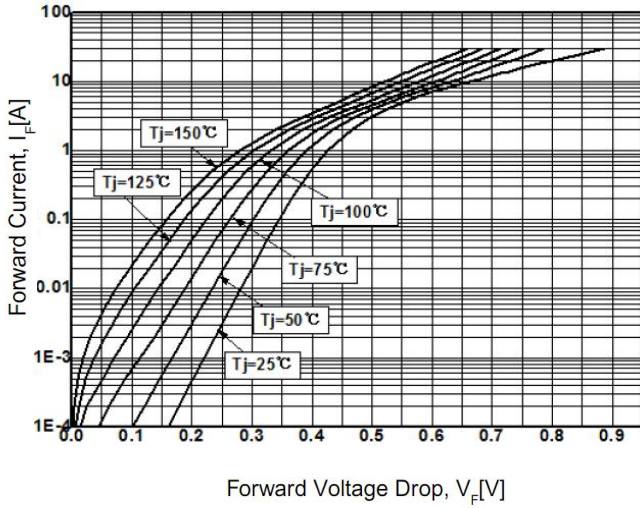

Figure 2. Reverse Leakage Current

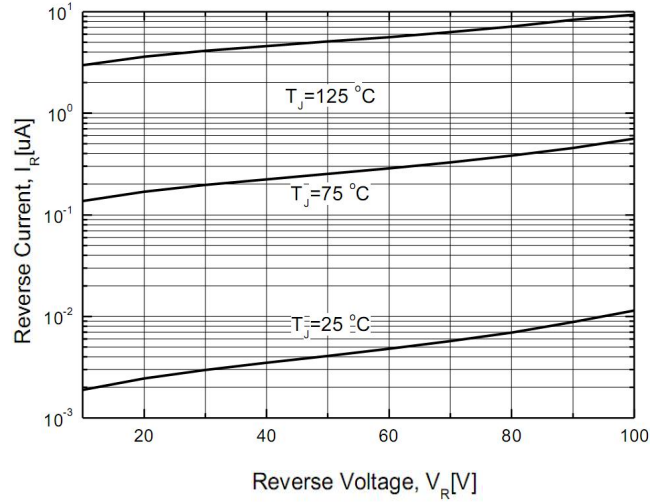

Figure 3. Junction Capacitance

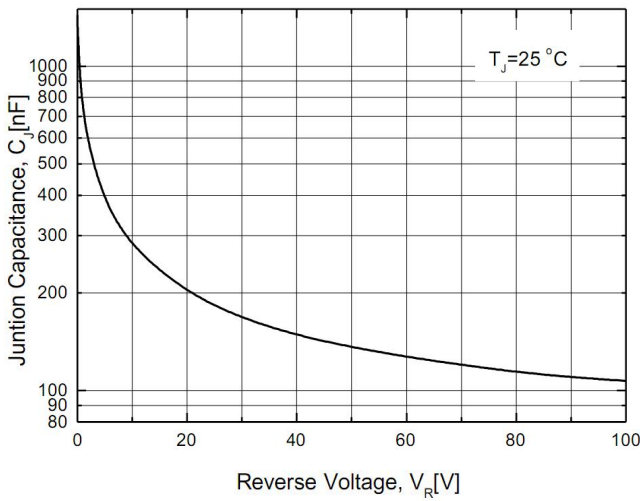
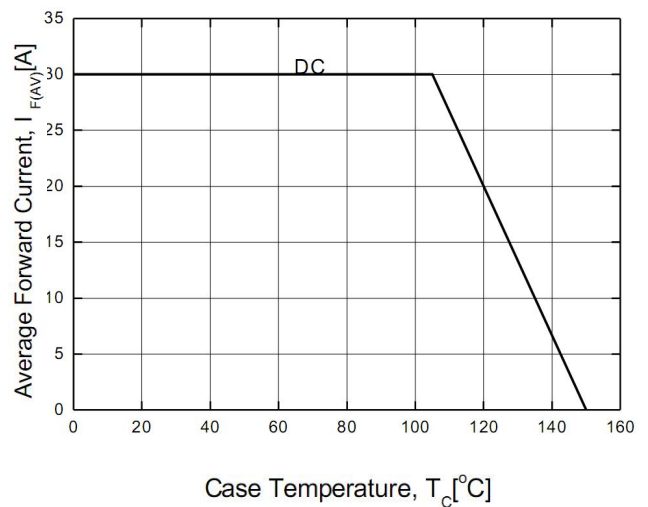

Figure 4. Power Derating





### Package Outline

#### TO-220F

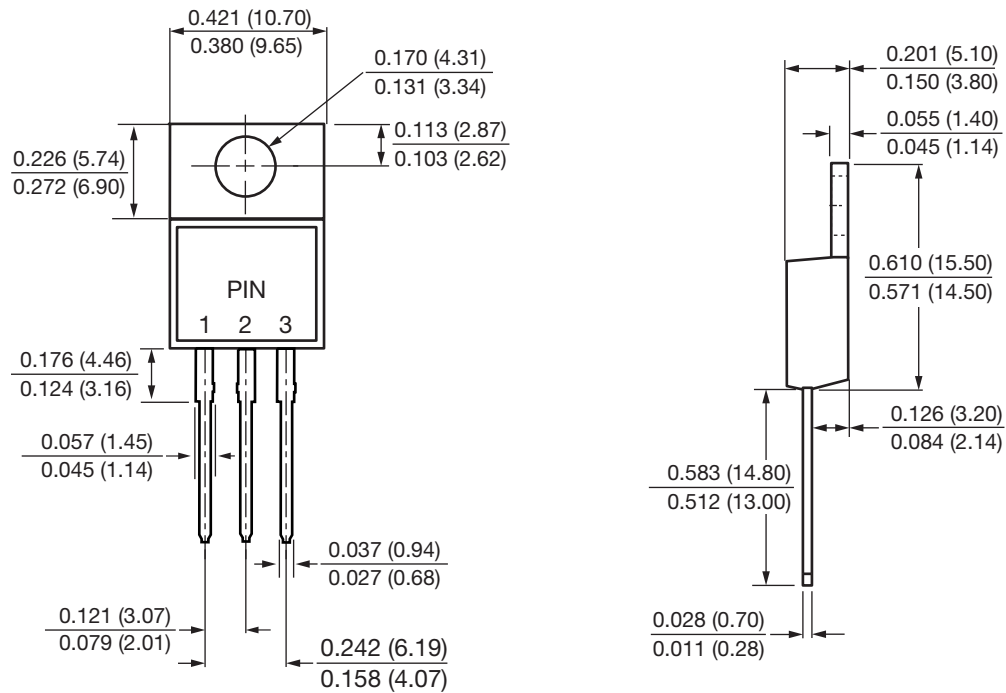

Dimensions in inches and (millimeters)

- TRR is registered trademark of Zhejiang TRR Microelectronics Inc. Zhejiang TRR Microelectronics Inc reserves the right to make changes any product in this specification without notice.
- Zhejiang TRR Microelectronics Inc does not assure any liability arising out of the applications or use of any product described in this specification.
- Zhejiang TRR Microelectronics Inc advises customers to obtain the latest version of the device information before placing orders to verify that the required information is current.