

GENERAL TOLERANCE										USED ON
10 MAX	30 MAX	50 MAX	70 MAX	100 MAX	120 MAX	250 MAX	250 OVER	ANGLE	ECCENT	
±0.15	±0.20	±0.30	±0.40	±0.50	±0.75	±0.90	±1.4	±0.5°	0.1	

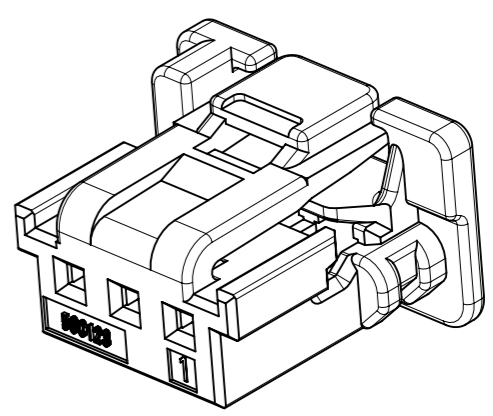

ISO VIEW

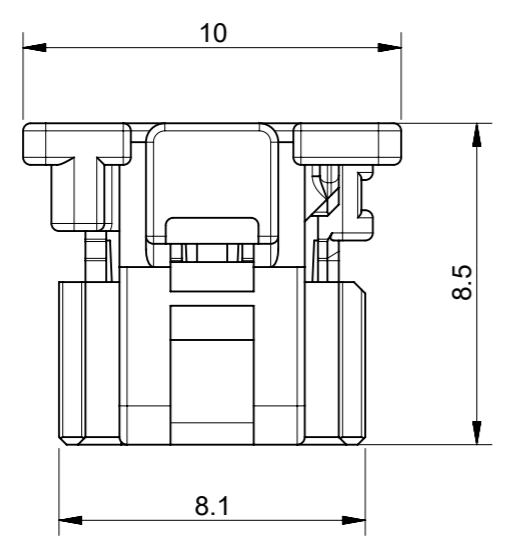
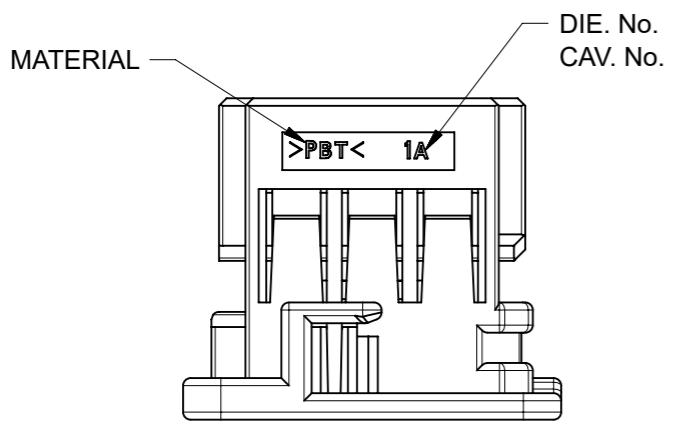
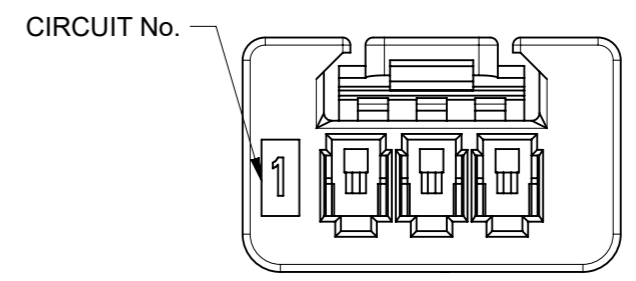
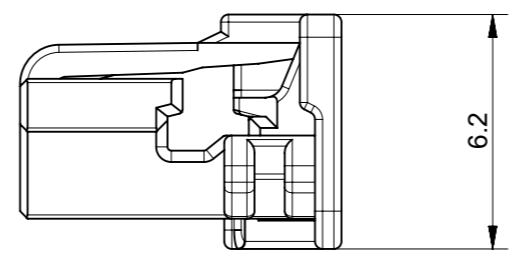
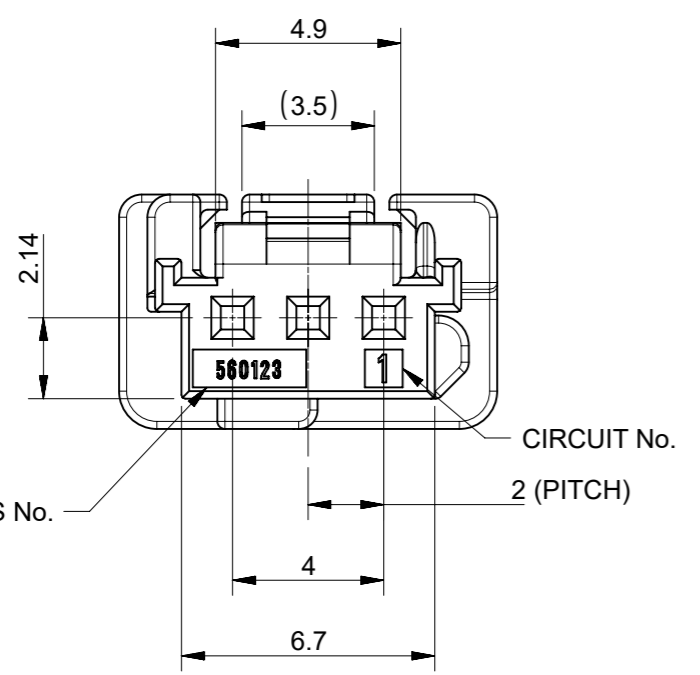

- NOTES:
1. MATERIALS : POLYESTER (PBT), GLASS UNFILLED, UL94 V-0
 2. MATE WITH : 502352, 560020 SERIES
 3. APPLICABLE TERMINAL : 560124 SERIES
 4. APPLICABLE ISL : 560125 SERIES
 5. GENERAL TOLERANCE : SEE TABLE
 6. EVL AND RoHS COMPLIANT
 7. PRODUCT SPECIFICATION : PS-560123-00*
 8. PACKING SPECIFICATION : PK-560123-001

MATERIAL NUMBER

ORDER NO.	MATERIAL NO.	COLOR
560123-0300	5601230300	WHITE
560123-0301	5601230301	BLACK
560123-0302	5601230302	RED
560123-0304	5601230304	BLUE

FUNCTIONAL SYMBOLS	THIS DRAWING CONTAINS INFORMATION THAT IS PROPRIETARY TO MOLEX ELECTRONIC TECHNOLOGIES, LLC AND SHOULD NOT BE USED WITHOUT WRITTEN PERMISSION	CURRENT REV DESC: DRAWING REMASTERED																											
	<table border="1"> <tr> <th>FUNCTIONAL SYMBOLS</th> <th>DIMENSION UNITS</th> <th>SCALE</th> </tr> <tr> <td>$\nabla/A = 0$</td> <td>mm</td> <td>5:1</td> </tr> <tr> <td>$\nabla/E = 0$</td> <td colspan="2">GENERAL TOLERANCES (UNLESS SPECIFIED)</td> </tr> <tr> <td>$\nabla/E = 0$</td> <td colspan="2">ANGULAR TOL ± °</td> </tr> <tr> <td></td> <td>4 PLACES</td> <td>±</td> </tr> <tr> <td></td> <td>3 PLACES</td> <td>±</td> </tr> <tr> <td></td> <td>2 PLACES</td> <td>±</td> </tr> <tr> <td></td> <td>1 PLACE</td> <td>±</td> </tr> <tr> <td></td> <td>0 PLACES</td> <td>±</td> </tr> </table>	FUNCTIONAL SYMBOLS	DIMENSION UNITS	SCALE	$\nabla/A = 0$	mm	5:1	$\nabla/E = 0$	GENERAL TOLERANCES (UNLESS SPECIFIED)		$\nabla/E = 0$	ANGULAR TOL ± °			4 PLACES	±		3 PLACES	±		2 PLACES	±		1 PLACE	±		0 PLACES	±	EC NO: 641821 DRWN: SAKIM CHK'D: TOSADA APPR: TOSADA INITIAL REVISION: DRWN: YIBAEK APPR: SRTAK
FUNCTIONAL SYMBOLS	DIMENSION UNITS	SCALE																											
$\nabla/A = 0$	mm	5:1																											
$\nabla/E = 0$	GENERAL TOLERANCES (UNLESS SPECIFIED)																												
$\nabla/E = 0$	ANGULAR TOL ± °																												
	4 PLACES	±																											
	3 PLACES	±																											
	2 PLACES	±																											
	1 PLACE	±																											
	0 PLACES	±																											
DIVISIONAL SYMBOLS	<table border="1"> <tr> <th>DOCUMENT NUMBER</th> <th>DOC TYPE</th> <th>DOC PART</th> <th>REVISION</th> </tr> <tr> <td>SD-560123-003</td> <td>PSD</td> <td>001</td> <td>C2</td> </tr> </table>		DOCUMENT NUMBER	DOC TYPE	DOC PART	REVISION	SD-560123-003	PSD	001	C2	<table border="1"> <tr> <th>MATERIAL NUMBER</th> <th>CUSTOMER</th> <th>SHEET NUMBER</th> </tr> <tr> <td>SEE TABLE</td> <td>GENERAL MARKET</td> <td>1 OF 1</td> </tr> </table>	MATERIAL NUMBER	CUSTOMER	SHEET NUMBER	SEE TABLE	GENERAL MARKET	1 OF 1												
DOCUMENT NUMBER	DOC TYPE	DOC PART	REVISION																										
SD-560123-003	PSD	001	C2																										
MATERIAL NUMBER	CUSTOMER	SHEET NUMBER																											
SEE TABLE	GENERAL MARKET	1 OF 1																											
DRAFT WHERE APPLICABLE MUST REMAIN WITHIN DIMENSIONS		THIRD ANGLE PROJECTION	DRAWING A3-SIZE																										