

DATA SHEET

PS1117

1.0A LOW DROPOUT POSITIVE VOLTAGE REGULATOR

DESCRIPTION

The PS1117 series of positive adjustable and fixed regulators are designed to provide 1A with high efficiency. All internal circuitry is designed to operate down to 1.3V input to output differential. On-chip trimming adjusts the reference voltage to 1%.

FEATURES

- Adjustable or Fixed Output
- Output Current of 1A
- Low Dropout, 1.5V max at 1A Output Current
- 0.04% Line Regulation
- 0.2 % Load Regulation
- 100% Thermal Limit Burn-In
- Fast Transient Response
- Lead Free And Halogen-Free

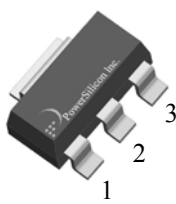
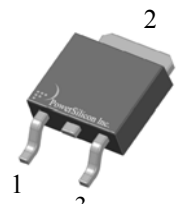
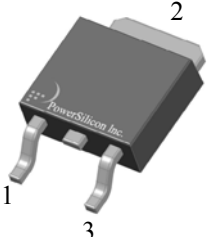
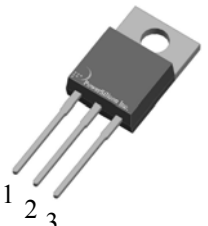

PIN CONFIGURATION

PIN CONFIGURATION		SOT-223	TO-252	TO-263	TO-220
1	ADJ/GND				
2	OUTPUT				
3	INPUT				

ORDERING INFORMATION

Part Number	Package	Shipping
PS1117-X.X-T43	SOT-223	Tape Reel
PS1117-X.X-TC2	TO-252	Tube
PS1117-X.X-TC2R	TO-252	Tape Reel
PS1117-X.X-TA2	TO-263	Tube
PS1117-X.X-TA2R	TO-263	Tape Reel
PS1117-X.X-TB3	TO-220	Tube

Marking Information:

AMS1117 SXX *****

Marking Code: AMS1117

Output Voltage Code: XX **EX:** 5.0V, XX=50

Date Code: ***** INNER CODE

SCHEMATIC DIAGRAM

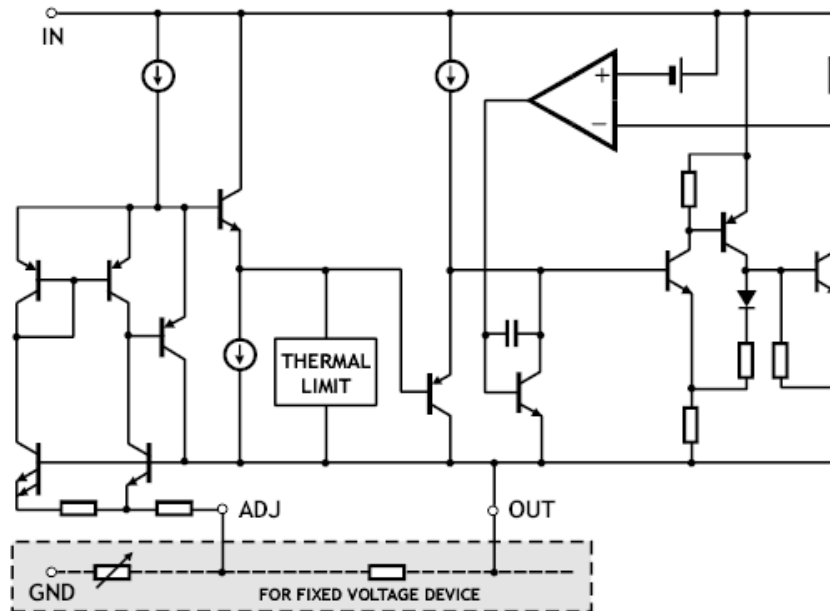

TYPICAL APPLICATION

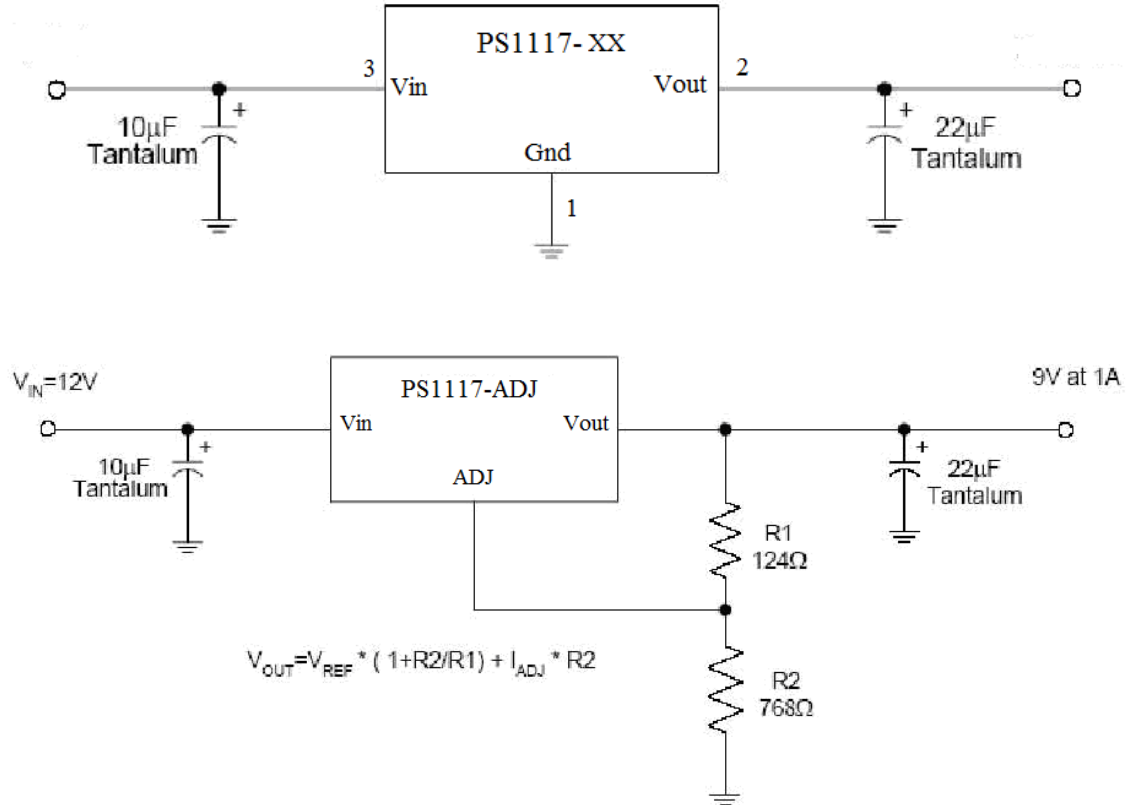

ABSOLUTE MAXIMUM RATINGS

($T_A = 25^\circ\text{C}$, unless otherwise specified.)

PARAMETER SYMBOL		RATING	UNIT
Input-to-output Differential Voltage, $V_{IN} - V_{OUT}$	V_{IN}	15	V
Power Dissipation	P_D	Internal limited	W
Operating Junction Temperature Range	T_{OPR}	-20 ~ +125	$^\circ\text{C}$
Storage Temperature Range	T_{STG}	-65 ~ +150	$^\circ\text{C}$
Lead Temperature (Soldering 10 sec)	T_{LEAD}	300	$^\circ\text{C}$

Note: Absolute Maximum Ratings are stress ratings only and functional device operation is not implied. The device could be permanently damaged beyond absolute maximum ratings.

ELECTRICAL CHARACTERISTICS
 $I_{LOAD} = 0mA$ and $T_J = 25^{\circ}C$ (unless otherwise noted)

PARAMETER TEST	CONDITIONS	MIN	TYP	MAX	UNIT
Reference Voltage (Note.1)	$V_{IN} = 5V, I_{LOAD} = 10mA$	1.238	1.25	1.262	V
	$V_{IN} - V_{OUT} = 1.5V \sim 10V,$ $I_{LOAD} = 10mA \sim 1A$	1.225	1.25	1.275	
Output Voltage (Note.1)	$V_{IN} - V_{OUT} = 1.5V,$ Variation from nominal V_{OUT}	-1	-	+1	%
	$V_{IN} - V_{OUT} = 1.5V \sim 10V$ $I_{LOAD} = 0mA \sim 1A,$ Variation from nominal V_{OUT}	-2	-	+2	
Line Regulation (Note.1)	$I_{LOAD} = 10mA,$ $V_{IN} - V_{OUT} = 1.5V \sim 10V$	-	0.04	0.2	%
Load Regulation (Note.1)	$V_{IN} - V_{OUT} = 1.5V$ $I_{LOAD} = 10mA \sim 1A$	-	0.2	0.4	
Minimum Load Current	$V_{IN} = 5V, V_{ADJ} = 0V$	-	3	7	mA
Ground Pin Current	$V_{IN} - V_{OUT} = 1.5V$ $I_{LOAD} = 10mA \sim 1A$	-	7	10	mA
Adjust Pin Current	$V_{IN} - V_{OUT} = 1.5V \sim 10V$ $I_{LOAD} = 10mA$	-	40	90	uA
Current Limit	$V_{IN} - V_{OUT} = 1.5V$	1	1.4	-	A
Ripple Rejection (Note.2)	$V_{IN} - V_{OUT} = 3V$ $I_{LOAD} = 1A$	60	65	-	dB
Dropout Voltage (Note.1,3)	$I_{LOAD} = 1A$	-	1.3	1.5	V
Temperature Coefficient	$V_{IN} - V_{OUT} = 1.5V,$ $I_{LOAD} = 10mA$	-	0.005	-	%/ $^{\circ}C$

The * denotes the specifications which apply over the full temperature range (see previous table, T_J)

Notes:

- 1: Low duty pulse testing with Kelvin connections required.
- 2: 120Hz input ripple (C_{ADJ} for ADJ = 25 μ F, C_{OUT} = 25 μ F)
- 3: $\Delta V_{OUT}, \Delta V_{REF} = 1\%$

SOT-223 DIMENSION

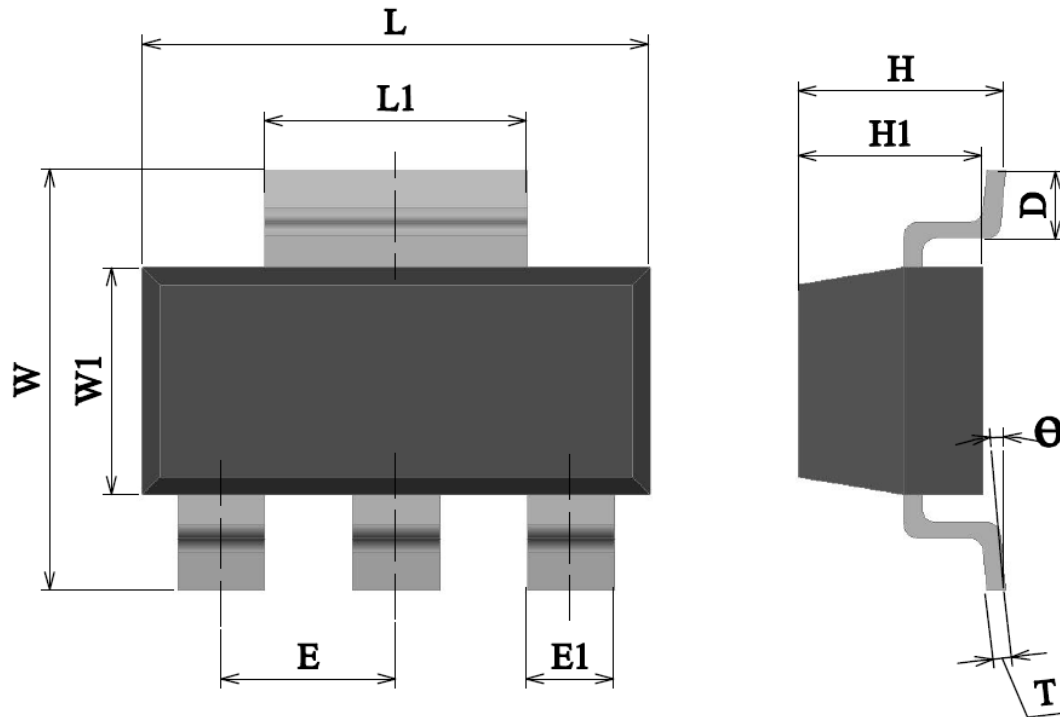

Symbol	Dimensions In Millimeters		Dimensions In Inches	
	Min	Max	Min	Max
L	6.30	6.71	0.248	0.264
L1	2.90	3.15	0.114	0.124
W	6.70	7.30	0.264	0.287
W1	3.33	3.71	0.131	0.146
E	2.30 BSC		0.091 BSC	
E1	0.60	0.84	0.024	0.033
H	1.52	1.80	0.060	0.071
H1	1.50	1.70	0.059	0.067
D	0.90	1.15	0.035	0.045
T	0.25	0.35	0.010	0.014
θ	0°	10°	0°	10°

TO-252(DPAK) DIMENSION

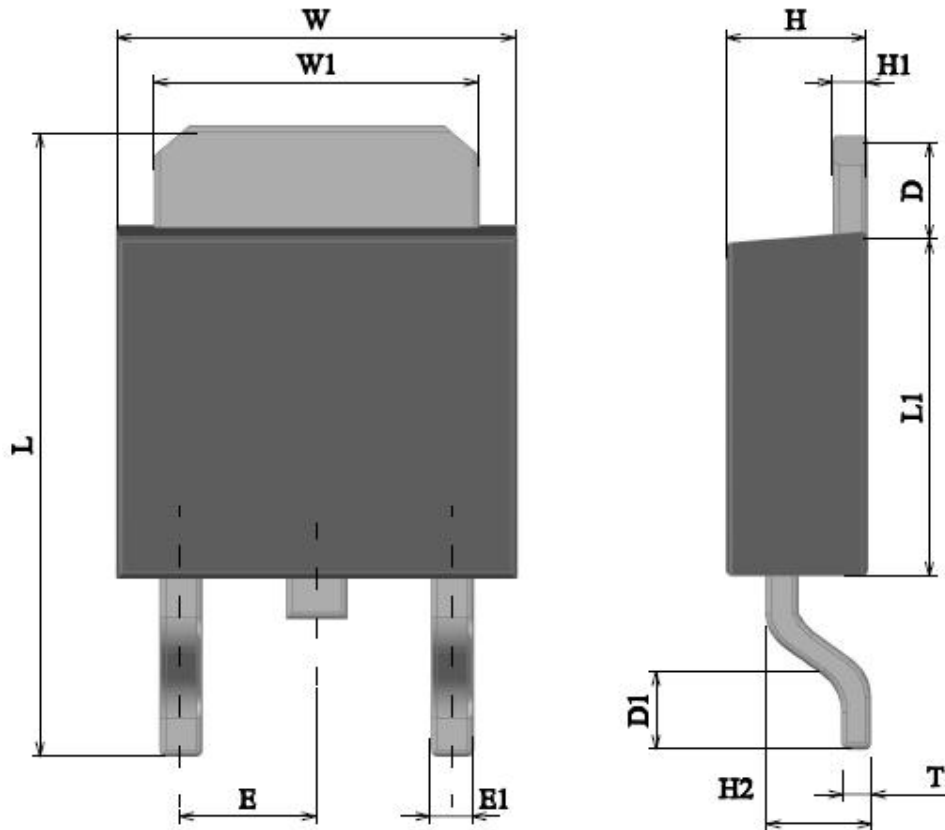

Symbol	Dimensions In Millimeters		Dimensions In Inches	
	Min	Max	Min	Max
L	8.00	10.00	0.315	0.394
L1	5.30	5.70	0.209	0.224
D	0.77	1.60	0.030	0.063
D1	0.51	1.78	0.020	0.070
W	6.30	6.80	0.248	0.268
W1	4.45	5.50	0.175	0.217
E	2.3 Nominal		0.091 Nominal	
E1	-	0.97	-	0.038
H	2.03	2.53	0.080	0.100
H1	0.40	1.01	0.016	0.040
H2	1.30	1.80	0.051	0.071
T	0.43	0.60	0.017	0.024

TO-263 DIMENSION

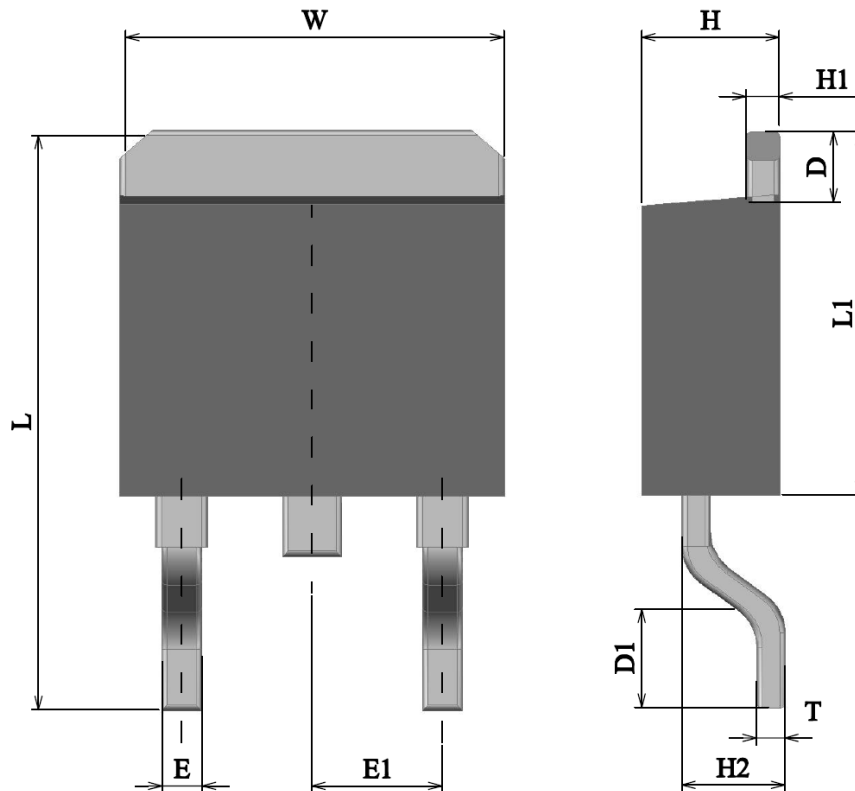

Symbol	Dimensions In Millimeters		Dimensions In Inches	
	Min	Max	Min	Max
L	14.60	15.88	0.575	0.625
L1	8.25	9.25	0.325	0.364
D	1.14	1.40	0.045	0.055
D1	2.29	2.79	0.090	0.110
W	9.65	10.69	0.380	0.421
E1	2.29	2.79	0.090	0.110
E	0.51	1.14	0.020	0.045
H	4.37	4.83	0.172	0.190
H1	1.40	1.41	0.055	0.056
H2	2.03	2.92	0.080	0.115
T	0.30	0.64	0.012	0.025

TO-220 DIMENSION

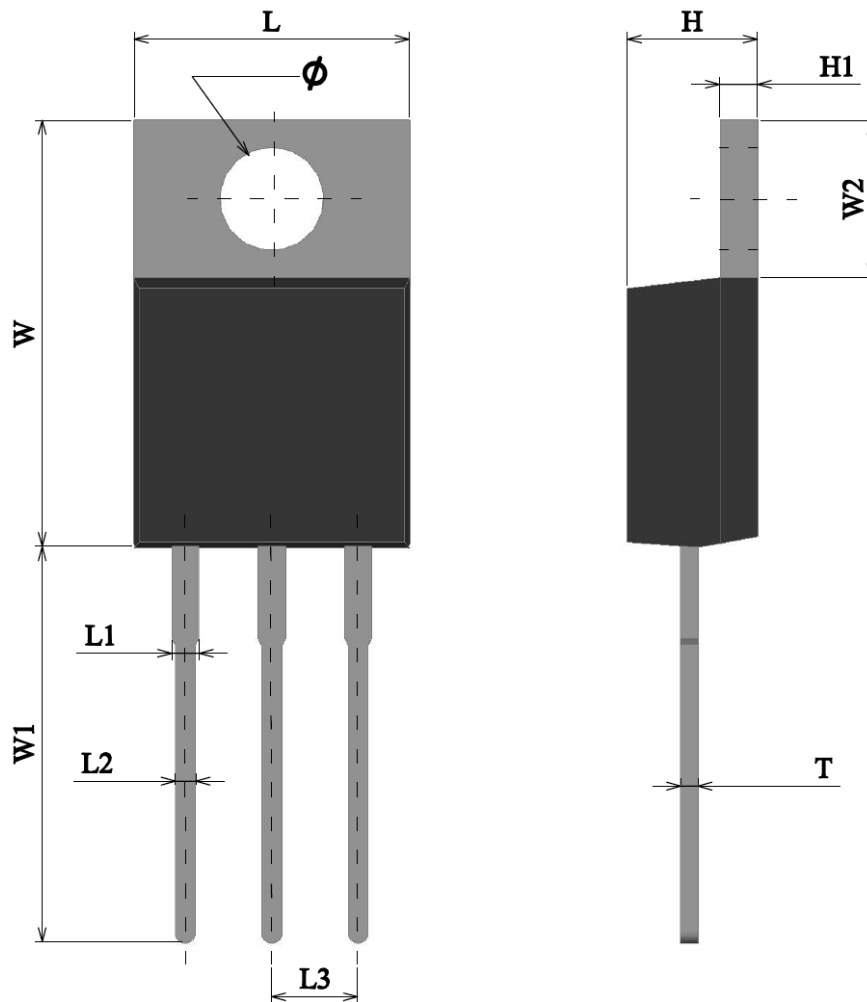

Symbol	Dimensions In Millimeters		Dimensions In Inches	
	Min	Max	Min	Max
L	9.65	10.67	0.380	0.420
L1	1.14	1.78	0.045	0.070
L2	0.50	1.15	0.020	0.045
L3	2.28	2.80	0.090	0.110
W	14.22	16.51	0.560	0.650
W1	12.70	14.74	0.500	0.580
W2	5.58	7.49	0.220	0.295
H	2.03	4.83	0.080	0.190
H1	0.50	1.40	0.020	0.055
T	0.30	1.15	0.012	0.045
φ	0.36	0.64	0.014	0.025