

BXF Series

• 105°C 2,000Hrs assured.

- Solvent proof.
- Ultra low ESR.
- For STB, Tuner.
- RoHS compliant.
- Halogen-free capacitors are also available.

• AEC-Q200 compliant : Please contact us for more details, test data, information.

Solvent-proof

BXJ

Low ESR

BXF



SPECIFICATIONS

Item	Characteristics																					
Rated Voltage Range	6.3 ~ 50 V _{DC}																					
Operating Temperature Range	-55 ~ +105°C																					
Capacitance Tolerance	±20% (M) (at 20°C, 120Hz)																					
Leakage Current	I = 0.01CV(μA) or 3μA, whichever is greater. Where, I:Max. Leakage current(μA), C:Nominal capacitance(μF), V:Rated voltage(V _{DC}) (at 20°C, 2 minutes)																					
Dissipation Factor(Tanδ)	<table border="1" style="margin: auto;"> <tr> <td>Rated Voltage(V_{DC})</td> <td>6.3</td> <td>10</td> <td>16</td> <td>25</td> <td>35</td> <td>50</td> </tr> <tr> <td>Tanδ (Max.)</td> <td>0.26</td> <td>0.19</td> <td>0.16</td> <td>0.14</td> <td>0.12</td> <td>0.12</td> </tr> </table>	Rated Voltage(V _{DC})	6.3	10	16	25	35	50	Tanδ (Max.)	0.26	0.19	0.16	0.14	0.12	0.12							
	Rated Voltage(V _{DC})	6.3	10	16	25	35	50															
Tanδ (Max.)	0.26	0.19	0.16	0.14	0.12	0.12																
(at 20°C, 120Hz)																						
Temperature Characteristics (Max. Impedance ratio)	<table border="1" style="margin: auto;"> <tr> <td>Rated voltage(V_{DC})</td> <td>6.3</td> <td>10</td> <td>16</td> <td>25</td> <td>35</td> <td>50</td> </tr> <tr> <td>Z(-25°C)/Z(+20°C)</td> <td>2</td> <td>2</td> <td>2</td> <td>2</td> <td>2</td> <td>2</td> </tr> <tr> <td>Z(-55°C)/Z(+20°C)</td> <td>4</td> <td>4</td> <td>4</td> <td>3</td> <td>3</td> <td>3</td> </tr> </table>	Rated voltage(V _{DC})	6.3	10	16	25	35	50	Z(-25°C)/Z(+20°C)	2	2	2	2	2	2	Z(-55°C)/Z(+20°C)	4	4	4	3	3	3
	Rated voltage(V _{DC})	6.3	10	16	25	35	50															
	Z(-25°C)/Z(+20°C)	2	2	2	2	2	2															
Z(-55°C)/Z(+20°C)	4	4	4	3	3	3																
(at 120Hz)																						
Load Life	The following specifications shall be satisfied when the capacitors are restored to 20°C after the rated voltage is applied at 105°C for 2,000hours. Capacitance change ≤ ±30 % of the initial value Tanδ ≤ 300 % of the initial specified value Leakage current ≤ The initial specified value																					
Shelf Life	The following specifications shall be satisfied when the capacitors are restored to 20°C after exposing them for 1,000 hours at 105°C without voltage applied. The rated voltage shall be applied to the capacitors for a minimum of 30 minutes, at least 24 hours and not more than 48 hours before the measurements. Capacitance change ≤ ±30 % of the initial value Tanδ ≤ 300 % of the initial specified value Leakage current ≤ The initial specified value																					
Others	Satisfied characteristics KS C IEC 60384-4																					

BXF Series

PART NUMBERING SYSTEM

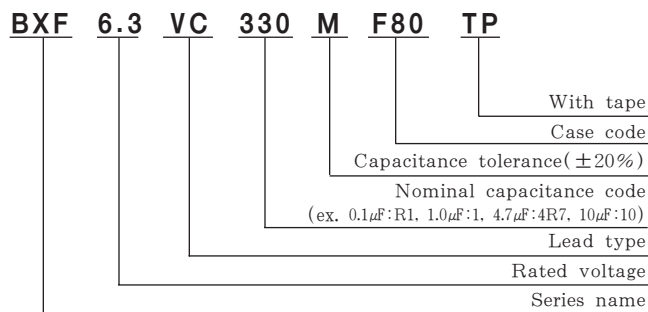

RATED RIPPLE CURRENT MULTIPLIERS

Frequency Multipliers

Cap.(μF) \ Freq.(Hz)	120	1K	10K	100K
68 ~ 100	0.40	0.75	0.90	1.00
220 ~ 560	0.50	0.85	0.94	1.00
680 ~ 1,500	0.60	0.87	0.95	1.00

DIMENSIONS OF BXF Series

Unit(mm)

DIMENSIONS

<Size code : F80~J10>

● Vibration Resistance
<Size code : H10~J10>

MARKING

Note 1 : L±0.5 for 8×10(H10)~10×10(J10)
Note 2 : 6.3WV is marked by 6V.

Case code	φ D	L	A	B	C	W	P	a	b	c	a	b	c
F80	6.3	7.7	6.6	6.6	7.2	0.5~0.8	1.9	1.9	3.5	1.6			
H10	8	10	8.3	8.3	9.0	0.7~1.1	3.1	3.1	4.2	2.2	3.1	4.2	3.5
J10	10	10	10.3	10.3	11.0	0.7~1.1	4.5	4.5	4.4	2.2	4.5	4.4	3.5

● Vibration Resistance →

Recommended solder land on PC board

▨ : Solder land on PC board

RATINGS OF BXF Series

μF	V _{DC}			6.3			10			16			25			35			50		
	Case code	a	b	a	b	c	a	b	c	a	b	c	a	b	c	a	b	c			
68													F80	0.16	600						
100										F80	0.16	600	F80	0.16	600	H10	0.34	350			
150									F80	0.16	600	H10	0.08	850	H10	0.08	850	J10	0.18	670	
220				F80	0.16	600	F80	0.16	600	H10	0.08	850	H10	0.09	850	J10	0.18	670			
330	F80	0.16	600	H10	0.08	850	H10	0.08	850	H10	0.08	850	J10	0.06	1,190						
470	H10	0.08	850	H10	0.08	850	H10	0.08	850	J10	0.06	1,190									
560	H10	0.08	850	H10	0.08	850	J10	0.06	1,190	J10	0.06	1,190									
680	H10	0.08	850	H10	0.08	850	J10	0.06	1,190												
820	H10	0.08	850	J10	0.06	1,190	J10	0.06	1,190												
1,000	H10	0.08	850	J10	0.06	1,190															
1,500	J10	0.06	1,190																		

↑ Rated Ripple Current (mA rms/105°C, 100kHz)
 ↑ ESR (Ω max./20°C, 100kHz)
 ↑ Case code

BXQ Series

• 105°C 2,000Hrs assured.

- Solvent proof.
- Ultra low ESR.
- For STB, Tuner, Car.
- RoHS compliant.
- Halogen-free capacitors are also available.
- AEC-Q200 compliant : Please contact us for more details, test data, information.

Solvent-proof



SPECIFICATIONS

Item	Characteristics																					
Rated Voltage Range	6.3 ~ 50 V _{DC}																					
Operating Temperature Range	-55 ~ +105°C																					
Capacitance Tolerance	± 20% (M) (at 20°C, 120Hz)																					
Leakage Current	I = 0.01CV(μA) or 3μA, whichever is greater. Where, I:Max. Leakage current(μA), C:Nominal capacitance(μF), V:Rated voltage(V _{DC}) (at 20°C, 2 minutes)																					
Dissipation Factor(Tan δ)	<table border="1" style="width: 100%; border-collapse: collapse; text-align: center;"> <tr> <td style="text-align: left;">Rated Voltage(V_{DC})</td> <td>6.3</td> <td>10</td> <td>16</td> <td>25</td> <td>35</td> <td>50</td> </tr> <tr> <td style="text-align: left;">Tan δ (Max.)</td> <td>0.26</td> <td>0.19</td> <td>0.16</td> <td>0.14</td> <td>0.12</td> <td>0.12</td> </tr> </table> (at 20°C, 120Hz)	Rated Voltage(V _{DC})	6.3	10	16	25	35	50	Tan δ (Max.)	0.26	0.19	0.16	0.14	0.12	0.12							
Rated Voltage(V _{DC})	6.3	10	16	25	35	50																
Tan δ (Max.)	0.26	0.19	0.16	0.14	0.12	0.12																
Temperature Characteristics (Max. Impedance ratio)	<table border="1" style="width: 100%; border-collapse: collapse; text-align: center;"> <tr> <td style="text-align: left;">Rated voltage(V_{DC})</td> <td>6.3</td> <td>10</td> <td>16</td> <td>25</td> <td>35</td> <td>50</td> </tr> <tr> <td style="text-align: left;">Z(-25°C)/Z(+20°C)</td> <td>2</td> <td>2</td> <td>2</td> <td>2</td> <td>2</td> <td>2</td> </tr> <tr> <td style="text-align: left;">Z(-55°C)/Z(+20°C)</td> <td>4</td> <td>4</td> <td>4</td> <td>3</td> <td>3</td> <td>3</td> </tr> </table> (at 120Hz)	Rated voltage(V _{DC})	6.3	10	16	25	35	50	Z(-25°C)/Z(+20°C)	2	2	2	2	2	2	Z(-55°C)/Z(+20°C)	4	4	4	3	3	3
Rated voltage(V _{DC})	6.3	10	16	25	35	50																
Z(-25°C)/Z(+20°C)	2	2	2	2	2	2																
Z(-55°C)/Z(+20°C)	4	4	4	3	3	3																
Load Life	The following specifications shall be satisfied when the capacitors are restored to 20°C after the rated voltage is applied at 105°C for 2,000hours. Capacitance change ≤ ±30 % of the initial value Tan δ ≤ 300 % of the initial specified value Leakage current ≤ The initial specified value																					
Shelf Life	The following specifications shall be satisfied when the capacitors are restored to 20°C after exposing them for 1,000 hours at 105°C without voltage applied. The rated voltage shall be applied to the capacitors for a minimum of 30 minutes, at least 24 hours and not more than 48 hours before the measurements. Capacitance change ≤ ±30 % of the initial value Tan δ ≤ 300 % of the initial specified value Leakage current ≤ The initial specified value																					
Others	Satisfied characteristics KS C IEC 60384-4																					

BXQ Series

PART NUMBERING SYSTEM

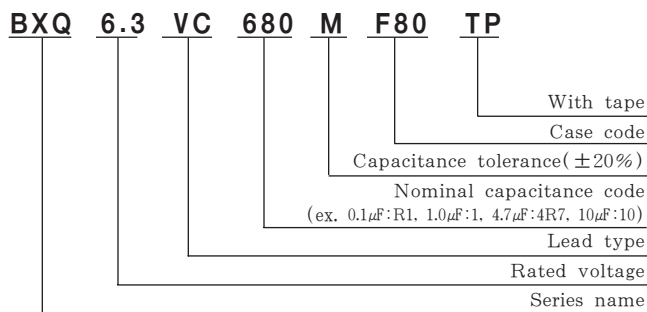

RATED RIPPLE CURRENT MULTIPLIERS

Frequency Multipliers

Cap.(μF) \ Freq.(Hz)	120	1K	10K	100K
47 ~ 150	0.40	0.75	0.90	1.00
220 ~ 560	0.50	0.85	0.94	1.00
680 ~ 2,200	0.60	0.87	0.95	1.00

DIMENSIONS OF BXQ Series

Unit(mm)

DIMENSIONS

<Size code : E61~K14>

● Vibration Resistance

<Size code : H10~K14>

MARKING

Recommended solder land on PC board

▨ : Solder land on PC board

Note 1 : L±0.5 for 8×10(H10)~12.5×13.5(K14)
 Note 2 : 6.3WV is marked by 6V.

Case code	φ D	L	A	B	C	W	P	a	b	c	a	b	c
E61	5	5.8	5.3	5.3	5.9	0.5~0.8	1.4	1.4	3.0	1.6			
F80	6.3	7.7	6.6	6.6	7.2	0.5~0.8	1.9	1.9	3.5	1.6			
H10	8	10	8.3	8.3	9.0	0.7~1.1	3.1	3.1	4.2	2.2	3.1	4.2	3.5
J10	10	10	10.3	10.3	11.0	0.7~1.1	4.5	4.5	4.4	2.2	4.5	4.4	3.5
K14	12.5	13.5	13.0	13.0	13.7	1.0~1.3	4.2	4.0	5.7	2.5	3.4	6.3	9.3

● Vibration Resistance →

RATINGS OF BXQ Series

Vdc	Cap.(μF)	Case code	ESR (Ω max. / 20°C, 100kHz)	Rated Ripple Current (mArms / 105°C, 100kHz)
6.3	680	F80	0.16	600
	1,500	H10	0.08	850
	2,200	J10	0.06	1,190
10	470	F80	0.16	600
	1,000	H10	0.08	850
	1,500	J10	0.06	1,190
16	100	E61	0.36	240
	330	F80	0.16	600
	680	H10	0.08	850
	1,000	J10	0.06	1,190
	1,800	K14	0.08	1,300
25	68	E61	0.36	240
	220	F80	0.16	600
	470	H10	0.08	850
	820	J10	0.06	1,190
	1,000	J10	0.06	1,190
	1,200	K14	0.08	1,300
35	47	E61	0.36	240
	150	F80	0.16	600
	330	H10	0.08	850
	560	J10	0.06	1,190
	680	J10	0.075	1,190
	1,000	K14	0.08	1,300
50	100	F80	0.34	350
	220	H10	0.18	670
	330	J10	0.12	900

BXW Series

• 105°C 3000~5,000Hrs assured.

- Vertical SMD type
- Ultra low ESR, Long Life
- For STB, Tuner, Car
- RoHS compliant.
- Halogen-free capacitors are also available.
- AEC-Q200 compliant : Please contact us for more details, test data, information.

Solvent-proof



SPECIFICATIONS

Item	Characteristics																					
Rated Voltage Range	6.3 ~ 50 V _{DC}																					
Operating Temperature Range	-55 ~ +105°C																					
Capacitance Tolerance	±20% (M) (at 20°C, 120Hz)																					
Leakage Current	I = 0.01CV(μA) or 3μA, whichever is greater. Where, I:Max. Leakage current(μA), C:Nominal capacitance(μF), V:Rated voltage(V _{DC}) (at 20°C, 2 minutes)																					
Dissipation Factor(Tanδ)	<table border="1" style="width: 100%; border-collapse: collapse; text-align: center;"> <tr> <td style="width: 20%;">Rated Voltage(V_{DC})</td> <td>6.3</td> <td>10</td> <td>16</td> <td>25</td> <td>35</td> <td>50</td> </tr> <tr> <td>Tanδ (Max.)</td> <td>0.26</td> <td>0.19</td> <td>0.16</td> <td>0.14</td> <td>0.12</td> <td>0.12</td> </tr> </table> (at 20°C, 120Hz)	Rated Voltage(V _{DC})	6.3	10	16	25	35	50	Tanδ (Max.)	0.26	0.19	0.16	0.14	0.12	0.12							
Rated Voltage(V _{DC})	6.3	10	16	25	35	50																
Tanδ (Max.)	0.26	0.19	0.16	0.14	0.12	0.12																
Temperature Characteristics (Max. Impedance ratio)	<table border="1" style="width: 100%; border-collapse: collapse; text-align: center;"> <tr> <td style="width: 20%;">Rated voltage(V_{DC})</td> <td>6.3</td> <td>10</td> <td>16</td> <td>25</td> <td>35</td> <td>50</td> </tr> <tr> <td>Z(-25°C)/Z(+20°C)</td> <td>2</td> <td>2</td> <td>2</td> <td>2</td> <td>2</td> <td>2</td> </tr> <tr> <td>Z(-55°C)/Z(+20°C)</td> <td>4</td> <td>4</td> <td>4</td> <td>3</td> <td>3</td> <td>3</td> </tr> </table> (at 120Hz)	Rated voltage(V _{DC})	6.3	10	16	25	35	50	Z(-25°C)/Z(+20°C)	2	2	2	2	2	2	Z(-55°C)/Z(+20°C)	4	4	4	3	3	3
Rated voltage(V _{DC})	6.3	10	16	25	35	50																
Z(-25°C)/Z(+20°C)	2	2	2	2	2	2																
Z(-55°C)/Z(+20°C)	4	4	4	3	3	3																
Load Life	<p>The following specifications shall be satisfied when the capacitors are restored to 20°C after the rated voltage is applied for 3,000~5,000hours at 105°C.</p> <p>Capacitance change ≤ ±30 % of the initial value Tanδ ≤ 300 % of the initial specified value Leakage current ≤ The initial specified value</p>																					
Shelf Life	<p>The following specifications shall be satisfied when the capacitors are restored to 20°C after exposing them for 1,000 hours at 105°C without voltage applied. The rated volage shall be applied to the capacitors for a minimum of 30 minutes, at least 24 hours and not more than 48 hours before the measurements.</p> <p>Capacitance change ≤ ±30 % of the initial value Tanδ ≤ 300 % of the initial specified value Leakage current ≤ The initial specified value</p>																					
Others	Satisfied characteristics KS C IEC 60384-4																					

BXW Series

PART NUMBERING SYSTEM

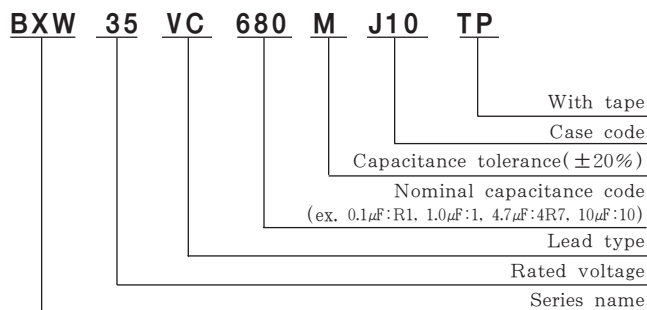

RATED RIPPLE CURRENT MULTIPLIERS

Frequency Multipliers

Cap.(μF) \ Freq.(Hz)	120	1K	10K	100K
68 ~ 150	0.40	0.75	0.90	1.00
180 ~ 560	0.50	0.85	0.94	1.00
680 ~ 2,200	0.60	0.87	0.95	1.00

DIMENSIONS OF BXW Series

Unit(mm)

DIMENSIONS

<Size code : F80~J10>

● Vibration Resistance

<Size code : F80~J10>

MARKING

Recommended solder land on PC board

▨ : Solder land on PC board

Note 1 : L±0.5 for H10 , J10
 Note 2 : 6.3WV is marked by 6V.

Case code	φ D	L	A	B	C	W	P	a	b	c	a	b	c
F80	6.3	7.7	6.6	6.6	7.2	0.5~0.8	1.9	1.9	3.5	1.6			
H10	8	10	8.3	8.3	9.0	0.7~1.1	3.1	3.1	4.2	2.2	3.1	4.2	3.5
J10	10	10	10.3	10.3	11.0	0.7~1.1	4.5	4.5	4.4	2.2	4.5	4.4	3.5

● Vibration Resistance → ↑

RATINGS OF BXW Series

Endurance : 105°C 3,000 hours

Endurance : 105°C 5,000 hours

Vdc	Cap.(μF)	Case Code	ESR (Ωmax./20°C,100kHz)	Rated Ripple Current (mA _{RMS} /105°C,100kHz)
6.3	680	F80	0.16	600
	1,500	H10	0.08	850
	2,200	J10	0.06	1,190
10	470	F80	0.16	600
	1,000	H10	0.08	850
	1,500	J10	0.06	1,190
16	330	F80	0.16	600
	680	H10	0.08	850
	1,000	J10	0.06	1,190
25	220	F80	0.16	600
	470	H10	0.08	850
	1,000	J10	0.06	1,190
35	150	F80	0.16	600
	330	H10	0.08	850
	680	J10	0.075	1,190
50	100	F80	0.34	350
	220	H10	0.18	670
	330	J10	0.12	900

Vdc	Cap.(μF)	Case Code	ESR (Ωmax./20°C,100kHz)	Rated Ripple Current (mA _{RMS} /105°C,100kHz)
6.3	470	F80	0.30	420
	1,000	H10	0.16	600
	1,500	J10	0.08	850
10	330	F80	0.30	420
	820	H10	0.16	600
	1,200	J10	0.08	850
16	270	F80	0.30	420
	680	H10	0.08	850
	1,000	J10	0.06	1,190
25	180	F80	0.30	420
	470	H10	0.08	850
	820	J10	0.06	1,190
35	120	F80	0.30	420
	330	H10	0.08	850
	560	J10	0.06	1,190
50	68	F80	0.40	250
	180	H10	0.18	670
	270	J10	0.14	750

BDA Series

• 105°C 2,000Hrs assured.

Solvent-proof

- Vertical SMD type.
- Long Life.
- For LED MT/TV, Copying Machine.
- RoHS compliant.
- Halogen-free capacitors are also available.

BDS
(MVK)

→ Long Life

BDA

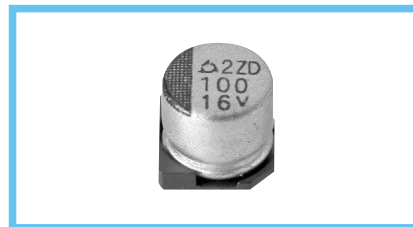

SPECIFICATIONS

Item	Characteristics								
Rated Voltage Range	4 ~ 50 V _{DC}								
Operating Temperature Range	-40 ~ +105°C								
Capacitance Tolerance	±20%(M) (at 20°C, 120Hz)								
Leakage Current	I = 0.01CV(μA) or 3μA, whichever is greater. Where, I: Max. Leakage current(μA), C: Nominal capacitance(μF), V: Rated voltage(V _{DC}) (at 20°C, 2 minutes)								
Dissipation Factor(Tanδ)	Rated voltage(V _{DC})	4	6.3	10	16	25	35	50	(at 20°C, 120Hz)
	Tanδ(Max.)	0.37	0.28	0.24	0.20	0.16	0.13	0.12	
Temperature Characteristics (Max. Impedance ratio)	Rated voltage(V _{DC})	4	6.3	10	16	25~50		(at 120Hz)	
	Z(-25°C)/Z(20°C)	6	3	3	2	2			
	Z(-40°C)/Z(20°C)	12	8	5	4	3			
Load Life	The following specifications shall be satisfied when the capacitors are restored to 20°C after the rated voltage applied for 2,000 hours at 105°C.								
	Rated voltage(V _{DC})	4 ~ 16			25 ~ 50				
	Capacitance change	≤ ±25% of the initial value			≤ ±20% of the initial value				
	Tanδ	≤ 200% of the initial specified value							
Shelf Life	The following specifications shall be satisfied when the capacitors are restored to 20°C after exposing them for 1,000 hours at 105°C without voltage applied. The rated voltage shall be applied to the capacitors for a minimum of 30 minutes, at least 24 hours and not more than 48 hours before the measurements.								
	Rated voltage(V _{DC})	4 ~ 16			25 ~ 50				
	Capacitance change	≤ ±25% of the initial value			≤ ±20% of the initial value				
	Tanδ	≤ 200% of the initial specified value							
Others	Satisfied characteristics KS C IEC 60384-4								

BDA Series

PART NUMBERING SYSTEM

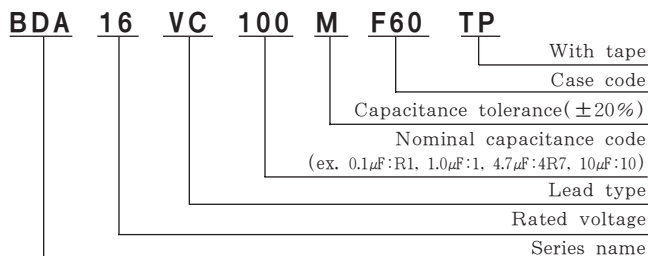

RATED RIPPLE CURRENT MULTIPLIERS

Frequency Multipliers

Cap.(μF)	Freq.(Hz)			
	120	1K	10K	100K
1	1.00	1.50	1.75	1.80
2.2 ~ 10	1.00	1.30	1.40	1.50
22 ~ 100	1.00	1.05	1.08	1.08

DIMENSIONS OF BDA Series

Unit(mm)

DIMENSIONS

MARKING

Note 1 : 4×5.2(D55), 5×5.2(E55) is excluded symbol mark.
 Note 2 : 6.3WV is marked by 6V.

Case code	φ D	L	A	B	C	W	P	a	b	c
D55	4	5.2	4.3	4.3	5.1	0.5~0.8	1.0	1.0	2.6	1.6
E55	5	5.2	5.3	5.3	5.9	0.5~0.8	1.4	1.4	3.0	1.6
F55	6.3	5.2	6.6	6.6	7.2	0.5~0.8	1.9	1.9	3.5	1.6
F60	6.3	5.7	6.6	6.6	7.2	0.5~0.8	1.9	1.9	3.5	1.6

Recommended solder land on PC board

: Solder land on PC board

RATINGS OF BDA Series

V _{DC} μF	4		6.3		10		16		25		35		50	
	1													D55
2.2													D55	10
3.3													D55	14
4.7									D55	13	D55	15	E55	19
10							D55	16	E55	25	E55	25	F55	29
22	D55	19	D55	21	E55	30	E55	30	F55	40	F55	40		
33	E55	30	E55	34	E55	34	F55	45	F55	45				
47	E55	34	E55	36	F55	48	F55	48	F60	52				
100	E55	45	F60	56	F60	90	F60	110						

↑ ↑
 Rated Ripple Current (mA rms/105°C, 120Hz)
 Case code

BLA Series

• 105°C 5,000Hrs assured.

- Vertical SMD type.
- Long Life.
- For LED MT, AVN.
- RoHS compliant.
- Halogen-free capacitors are also available.
- AEC-Q200 compliant : Please contact us for more details, test data, information.

Solvent-proof

WV ≤ 63V_{DC}

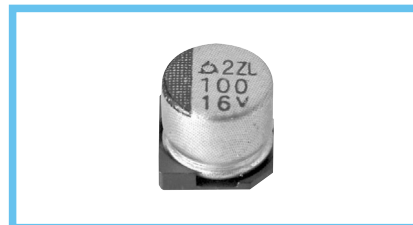

SPECIFICATIONS

Item	Characteristics										
Rated Voltage Range	4 ~ 400 V _{DC}										
Operating Temperature Range	-40 ~ +105°C										
Capacitance Tolerance	±20%(M) (at 20°C, 120Hz)										
Leakage Current	Rated Voltage(V _{DC})	4~100								160~400	
	Max. Leakage current(μA)	0.01CV (μA) or 3μA, whichever is greater. (at 20°C, 2 minutes)								0.04CV+100(μA) (at 20°C, 1 minute)	
Dissipation Factor(Tan δ)	Rated voltage(V _{DC})	4	6.3	10	16	25	35	50	63~100	160~250	400
	Tan δ(Max.)	0.37	0.28	0.24	0.20	0.16	0.13	0.12	0.12	0.15	0.20
(at 20°C, 120Hz)											
Temperature Characteristics (Max. Impedance ratio)	Rated voltage(V _{DC})	4	6.3	10	16	25~50	63~100	160~250	400		
	Z(-25°C)/Z(+20°C)	8	4	3	2	2	3	3	6		
	Z(-40°C)/Z(+20°C)	14	10	7	5	3	4	6	10		
(at 120Hz)											
Load Life	The following specifications shall be satisfied when the capacitors are restored to 20°C after the rated voltage is applied for 5,000 hours at 105°C. Capacitance change ≤ ±30% of the initial value Tan δ ≤ 300% of the initial specified value Leakage current ≤ The initial specified value										
Shelf Life	The following specifications shall be satisfied when the capacitors are restored to 20°C after exposing them for 1,000 hours at 105°C without voltage applied. The rated voltage shall be applied to the capacitors for a minimum of 30 minutes, at least 24 hours and not more than 48 hours before the measurements. Capacitance change ≤ ±30% of the initial value Tan δ ≤ 300% of the initial specified value Leakage current ≤ The initial specified value										
Others	Satisfied characteristics KS C IEC 60384-4										

BLA Series

PART NUMBERING SYSTEM

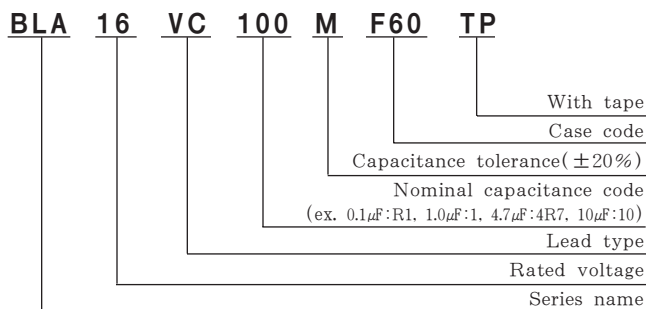

RATED RIPPLE CURRENT MULTIPLIERS

Frequency Multipliers

Freq.(Hz)	120	1K	10K	100K
Factor	1.00	1.05	1.08	1.08

DIMENSIONS OF BLA Series

Unit(mm)

DIMENSIONS

Safety Vent ($\geq \phi 10$)

①

Recommended solder land on PC board

■ : Solder land on PC board

MARKING

<D55 ~ J10>

<K14>

Note 1 : $L \pm 0.5$ for 8×10 (H10)~ 12.5×13.5 (K14)
 Note 2 : 4×5.2 (D55), 5×5.2 (E55) is excluded symbol mark.
 Note 3 : 6.3WV is marked by 6V.

Case code	ϕD	L	A	B	C	W	P	a	b	c
D55	4	5.2	4.3	4.3	5.1	0.5~0.8	1.0	1.0	2.6	1.6
E55	5	5.2	5.3	5.3	5.9	0.5~0.8	1.4	1.4	3.0	1.6
F55	6.3	5.2	6.6	6.6	7.2	0.5~0.8	1.9	1.9	3.5	1.6
F60	6.3	5.7	6.6	6.6	7.2	0.5~0.8	1.9	1.9	3.5	1.6
F80	6.3	7.7	6.6	6.6	7.2	0.5~0.8	1.9	1.9	3.5	1.6
H63	8	6.3	8.3	8.3	9.0	0.5~0.8	2.3	2.3	4.5	1.6
H10	8	10	8.3	8.3	9.0	0.7~1.1	3.1	3.1	4.2	2.2
J10	10	10	10.3	10.3	11.0	0.7~1.1	4.5	4.5	4.4	2.2
K14	12.5	13.5	13.0	13.0	13.7	1.0~1.3	4.2	4.0	5.7	2.5

RATINGS OF BLA Series

Vdc / μF	4	6.3	10	16	25	35	50	63	100
1							D55 5.6		
2.2							D55 10		
3.3							D55 14		
4.7					D55 13	D55 15	E55 19		
10				D55 16	E55 25	E55 25	F55 29	F60 32	H63 48
22	D55 19	D55 21	E55 30	E55 30	F55 40	F55 40	F60 43	H10 69	H10 91
33	E55 30	E55 34	E55 34	F55 45	F55 45	F80 57	H10 77	J10 96	J10 127
47	E55 34	E55 36	F55 48	F55 48	F60 52	H10 92	H10 92	J10 114	K14 193
100	E55 45	F60 56	F60 90	F60 110	H10 116	J10 151	J10 151	K14 212	K14 281
220			F80 120	H10 140	J10 216	J10 216	K14 221		
330			H10 170	J10 238	J10 238	K14 271			
470			J10 254	J10 254	K14 324				
1,000			K14 472	K14 472					

Vdc / μF	160	200	250	400
2.2				J10 26
3.3			J10 46	J10 37
4.7		J10 54	K14 65	K14 70
10	J10 79	J10 79	K14 102	
22	K14 148	K14 148		
33	K14 182			

↑ Rated Ripple Current (mArms/105°C, 120Hz)
 ↑ Case code

BLH Series

• 105°C 10,000Hrs assured.

Solvent-proof

- Vertical SMD type.
- Long Life.
- For LED MT/TV, AVN.
- RoHS compliant.
- Halogen-free capacitors are also available.



• AEC-Q200 compliant : Please contact us for more details, test data, information.

SPECIFICATIONS

Item	Characteristics												
Rated Voltage Range	10 ~ 50 V _{DC}												
Operating Temperature Range	-40 ~ +105°C												
Capacitance Tolerance	±20%(M) (at 20°C, 120Hz)												
Leakage Current	I = 0.01CV(μA) or 3μA, whichever is greater. Where, I:Max. Leakage current(μA), C:Nominal capacitance(μF), V:Rated voltage(V _{DC}) (at 20°C, 2 minutes)												
Dissipation Factor(Tanδ)	<table border="1" style="width: 100%; border-collapse: collapse; text-align: center;"> <tr> <td style="text-align: left;">Rated voltage(V_{DC})</td> <td>10</td> <td>16</td> <td>25</td> <td>35</td> <td>50</td> </tr> <tr> <td style="text-align: left;">Tanδ(Max.)</td> <td>0.24</td> <td>0.20</td> <td>0.16</td> <td>0.13</td> <td>0.12</td> </tr> </table> (at 20°C, 120Hz)	Rated voltage(V _{DC})	10	16	25	35	50	Tanδ(Max.)	0.24	0.20	0.16	0.13	0.12
Rated voltage(V _{DC})	10	16	25	35	50								
Tanδ(Max.)	0.24	0.20	0.16	0.13	0.12								
Temperature Characteristics (Max. Impedance ratio)	<table border="1" style="width: 100%; border-collapse: collapse; text-align: center;"> <tr> <td style="text-align: left;">Rated voltage(V_{DC})</td> <td>10</td> <td>16</td> <td>25~50</td> </tr> <tr> <td style="text-align: left;">Z(-25°C)/Z(+20°C)</td> <td>3</td> <td>2</td> <td>2</td> </tr> <tr> <td style="text-align: left;">Z(-40°C)/Z(+20°C)</td> <td>7</td> <td>5</td> <td>3</td> </tr> </table> (at 120Hz)	Rated voltage(V _{DC})	10	16	25~50	Z(-25°C)/Z(+20°C)	3	2	2	Z(-40°C)/Z(+20°C)	7	5	3
Rated voltage(V _{DC})	10	16	25~50										
Z(-25°C)/Z(+20°C)	3	2	2										
Z(-40°C)/Z(+20°C)	7	5	3										
Load Life	The following specifications shall be satisfied when the capacitors are restored to 20°C after the rated voltage is applied for 10,000 hours at 105°C. Capacitance change ≤ ±30% of the initial value Tanδ ≤ 300% of the initial specified value Leakage current ≤ The initial specified value												
Shelf Life	The following specifications shall be satisfied when the capacitors are restored to 20°C after exposing them for 1,000 hours at 105°C without voltage applied. The rated voltage shall be applied to the capacitors for a minimum of 30 minutes, at least 24 hours and not more than 48 hours before the measurements. Capacitance change ≤ ±30% of the initial value Tanδ ≤ 300% of the initial specified value Leakage current ≤ The initial specified value												
Others	Satisfied characteristics KS C IEC 60384-4												

BLH Series

PART NUMBERING SYSTEM

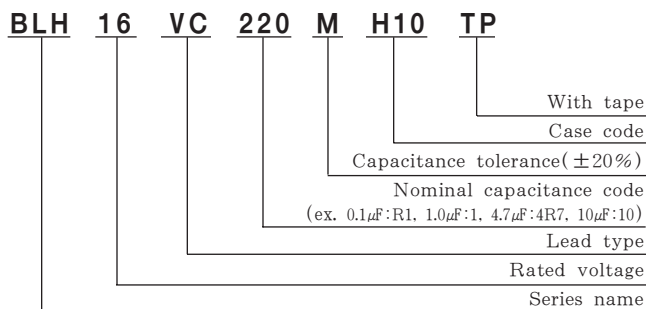

RATED RIPPLE CURRENT MULTIPLIERS

Frequency Multipliers

Freq.(Hz)	120	1K	10K	100K
Factor	1.00	1.05	1.08	1.08

DIMENSIONS OF BLH Series

Unit(mm)

DIMENSIONS

MARKING

Case code	φ D	L	A	B	C	W	P	a	b	c
H10	8	10	8.3	8.3	9.0	0.7~1.1	3.1	3.1	4.2	2.2
J10	10	10	10.3	10.3	11.0	0.7~1.1	4.5	4.5	4.4	2.2
K14	12.5	13.5	13.0	13.0	13.7	1.0~1.3	4.2	4.0	5.7	2.5

Recommended solder land on PC board

: Solder land on PC board

RATINGS OF BLH Series

Vdc μF	10	16	25	35	50
33					H10 77
47				H10 92	H10 92
100			H10 116	J10 151	J10 151
220		H10 140	J10 218	J10 216	K14 255
330	H10 170	J10 238	J10 238	K14 301	
470	J10 254	J10 254	K14 324		
1,000	K14 472	K14 472			

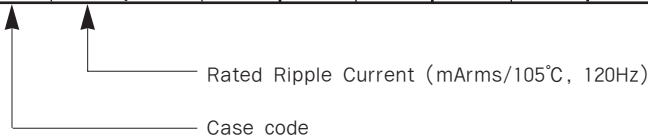

CLZ Series

• 125°C 1,000~5,000Hrs assured.

- Vertical SMD type.
- Wide Temp., Low ESR.
- Suitable to fit for automotive equipment.
- RoHS compliant.
- Halogen-free capacitors are also available.

• AEC-Q200 compliant : Please contact us for more details, test data, information.

Solvent-proof

WV ≤ 80V_{DC}

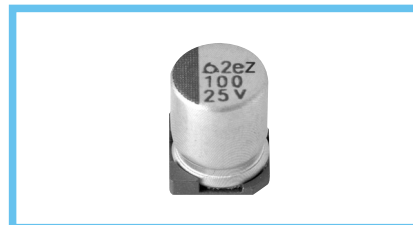
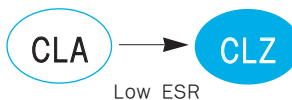

SPECIFICATIONS

Item	Characteristics																																	
Rated Voltage Range	10 ~ 400 V _{DC}																																	
Operating Temperature Range	-40 ~ +125°C																																	
Capacitance Tolerance	±20%(M)																																	
Leakage Current	<table border="1" style="width: 100%; border-collapse: collapse;"> <tr> <td style="width: 30%;">Rated voltage(V_{DC})</td> <td style="width: 35%;">10~100</td> <td style="width: 35%;">160~400</td> </tr> <tr> <td>Max. Leakage current (μA)</td> <td>I=0.01CV(μA) or 3μA, whichever is greater. (at 20°C, 2 minutes)</td> <td>0.04CV + 100(μA) (at 20°C, 2 minutes)</td> </tr> </table> <p style="text-align: center; font-size: small;">Where, C : Nominal capacitance(μF), V : Rated voltage(V_{DC})</p>	Rated voltage(V _{DC})	10~100	160~400	Max. Leakage current (μA)	I=0.01CV(μA) or 3μA, whichever is greater. (at 20°C, 2 minutes)	0.04CV + 100(μA) (at 20°C, 2 minutes)																											
Rated voltage(V _{DC})	10~100	160~400																																
Max. Leakage current (μA)	I=0.01CV(μA) or 3μA, whichever is greater. (at 20°C, 2 minutes)	0.04CV + 100(μA) (at 20°C, 2 minutes)																																
Dissipation Factor(Tanδ)	<table border="1" style="width: 100%; border-collapse: collapse;"> <tr> <td style="width: 15%;">Rated voltage(V_{DC})</td> <td style="width: 10%;">10</td> <td style="width: 10%;">16</td> <td style="width: 10%;">25</td> <td style="width: 10%;">35</td> <td style="width: 10%;">50~80</td> <td style="width: 10%;">100</td> <td style="width: 10%;">160~250</td> <td style="width: 10%;">400</td> </tr> <tr> <td>Tanδ(Max.)</td> <td>0.22</td> <td>0.19</td> <td>0.16</td> <td>0.14</td> <td>0.12</td> <td>0.10</td> <td>0.20</td> <td>0.24</td> </tr> </table> <p style="text-align: right; font-size: small;">(at 20°C, 120Hz)</p>	Rated voltage(V _{DC})	10	16	25	35	50~80	100	160~250	400	Tanδ(Max.)	0.22	0.19	0.16	0.14	0.12	0.10	0.20	0.24															
Rated voltage(V _{DC})	10	16	25	35	50~80	100	160~250	400																										
Tanδ(Max.)	0.22	0.19	0.16	0.14	0.12	0.10	0.20	0.24																										
Temperature Characteristics (Max. Impedance ratio)	<table border="1" style="width: 100%; border-collapse: collapse;"> <tr> <td style="width: 15%;">Rated voltage(V_{DC})</td> <td style="width: 10%;">10</td> <td style="width: 10%;">16</td> <td style="width: 10%;">25</td> <td style="width: 10%;">35~100</td> <td style="width: 10%;">160~250</td> <td style="width: 10%;">400</td> </tr> <tr> <td>Z(-25°C)/Z(+20°C)</td> <td>4</td> <td>3</td> <td>2</td> <td>2</td> <td>3</td> <td>6</td> </tr> <tr> <td>Z(-40°C)/Z(+20°C)</td> <td>8</td> <td>6</td> <td>4</td> <td>3</td> <td>6</td> <td>10</td> </tr> </table> <p style="text-align: right; font-size: small;">(at 120Hz)</p>	Rated voltage(V _{DC})	10	16	25	35~100	160~250	400	Z(-25°C)/Z(+20°C)	4	3	2	2	3	6	Z(-40°C)/Z(+20°C)	8	6	4	3	6	10												
Rated voltage(V _{DC})	10	16	25	35~100	160~250	400																												
Z(-25°C)/Z(+20°C)	4	3	2	2	3	6																												
Z(-40°C)/Z(+20°C)	8	6	4	3	6	10																												
Load Life	<p>The following specifications shall be satisfied when the capacitors are restored to 20°C after the rated voltage is applied for the specified time at 125°C.</p> <table style="width: 100%;"> <tr> <td style="width: 60%;">Capacitance change</td> <td style="width: 20%;">≤ ±30% of the initial value</td> <td style="width: 20%;"></td> </tr> <tr> <td>Tanδ</td> <td>≤ 300% of the initial specified value</td> <td></td> </tr> <tr> <td>Leakage current</td> <td>≤ The initial specified value</td> <td></td> </tr> </table> <table border="1" style="width: 100%; border-collapse: collapse; font-size: x-small;"> <tr> <th>Case Code</th> <th>10~80V</th> <th>100V</th> <th>160~400V</th> </tr> <tr> <td>D55~F60</td> <td>1,000Hrs</td> <td>-</td> <td>-</td> </tr> <tr> <td>H63</td> <td>3,000Hrs</td> <td>-</td> <td>-</td> </tr> <tr> <td>H10</td> <td>5,000Hrs</td> <td>2,000Hrs</td> <td>-</td> </tr> <tr> <td>J10</td> <td>5,000Hrs</td> <td>2,000Hrs</td> <td>2,000Hrs</td> </tr> <tr> <td>K14~M22</td> <td>5,000Hrs</td> <td>5,000Hrs</td> <td>2,000Hrs</td> </tr> </table>	Capacitance change	≤ ±30% of the initial value		Tanδ	≤ 300% of the initial specified value		Leakage current	≤ The initial specified value		Case Code	10~80V	100V	160~400V	D55~F60	1,000Hrs	-	-	H63	3,000Hrs	-	-	H10	5,000Hrs	2,000Hrs	-	J10	5,000Hrs	2,000Hrs	2,000Hrs	K14~M22	5,000Hrs	5,000Hrs	2,000Hrs
Capacitance change	≤ ±30% of the initial value																																	
Tanδ	≤ 300% of the initial specified value																																	
Leakage current	≤ The initial specified value																																	
Case Code	10~80V	100V	160~400V																															
D55~F60	1,000Hrs	-	-																															
H63	3,000Hrs	-	-																															
H10	5,000Hrs	2,000Hrs	-																															
J10	5,000Hrs	2,000Hrs	2,000Hrs																															
K14~M22	5,000Hrs	5,000Hrs	2,000Hrs																															
Shelf Life	<p>The following specifications shall be satisfied when the capacitors are restored to 20°C after exposing them for 1,000 hours at 125°C without voltage applied. The rated voltage shall be applied to the capacitors for a minimum of 30 minutes, at least 24 hours and not more than 48 hours before the measurements. (Where, D55 ~ F60 is 500 hours)</p> <p>Capacitance change ≤ ±30% of the initial value</p> <p>Tanδ ≤ 300% of the initial specified value</p> <p>Leakage current ≤ The initial specified value (where, 500% for ≥ WV 80 V_{DC})</p>																																	
Others	Satisfied characteristics KS C IEC 60384-4																																	

CLZ Series

PART NUMBERING SYSTEM

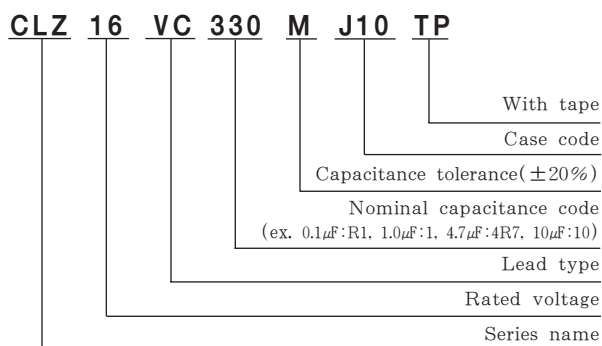

RATED RIPPLE CURRENT MULTIPLIERS

Frequency Multipliers

Rated Voltage(V _{DC})	Size code	Freq.(Hz)				
		Cap.(μF)	120	1K	10K	100K
10 ~ 100	D55 ~ J10	10	0.66	0.86	0.93	1.00
		22 ~ 470	0.93	0.97	1.00	1.00
	K14 ~ M22	47 ~ 100	0.40	0.75	0.90	1.00
		220 ~ 1,000	0.50	0.85	0.94	1.00
		2,200 ~ 3,300	0.75	0.90	0.95	1.00
160 ~ 400	J10 ~ M22	4,700	0.85	0.95	0.98	1.00
		2.2 ~ 33	1.00	1.50	1.75	1.80
		47 ~ 68	1.00	1.30	1.40	1.50

DIMENSIONS OF CLZ Series

Unit(mm)

DIMENSIONS

● Vibration Resistance

<Size code: D55~M22> <Size code: H10~M22>

■ : Dummy terminals

Recommended solder land on PC board

■ : Solder land on PC board

※Please inquire beforehand for 16, 18φ size

MARKING

Note 1 : L±0.5 for 8×6.3(H63)~18×21.5(M22)
 Note 2 : 4×5.2(D55), 5×5.2(E55) is excluded symbol mark.

Case code	φD	L	A	B	C	W	P	a	b	c	a	b	c
D55	4	5.2	4.3	4.3	5.1	0.5~0.8	1.0	1.0	2.6	1.6			
E55	5	5.2	5.3	5.3	5.9	0.5~0.8	1.4	1.4	3.0	1.6			
F55	6.3	5.2	6.6	6.6	7.2	0.5~0.8	1.9	1.9	3.5	1.6			
F60	6.3	5.7	6.6	6.6	7.2	0.5~0.8	1.9	1.9	3.5	1.6			
H63	8	6.3	8.3	8.3	9.0	0.5~0.8	2.3	2.3	4.5	1.6			
H10	8	10	8.3	8.3	9.0	0.7~1.1	3.1	3.1	4.2	2.2	3.1	4.2	3.5
J10	10	10	10.3	10.3	11.0	0.7~1.1	4.5	4.5	4.4	2.2	4.5	4.4	3.5
K14	12.5	13.5	13.0	13.0	13.7	1.0~1.3	4.2	4.0	5.7	2.5	3.4	6.3	9.3
L17	16	16.5	17.0	17.0	18.0	1.0~1.3	6.5	6.0	6.9	2.5			
L22	16	21.5	17.0	17.0	18.0	1.0~1.3	6.5	6.0	6.9	2.5	4.7	7.8	9.6
M17	18	16.5	19.0	19.0	20.0	1.0~1.3	6.5	6.0	7.9	2.5			
M22	18	21.5	19.0	19.0	20.0	1.0~1.3	6.5	6.0	7.9	2.5	4.7	8.8	9.6

● Vibration Resistance

RATINGS OF CLZ Series

V _{Dc} / μF	10			16			25			35			50			63			80			100		
10				D55 7.00	105	12	E55 3.30	49.5	23	F60 1.60	24.0	69	F60 2.80	42.0	51	H63 2.00	110	60	H10 1.20	80.4	70	H10 1.60	107.2	70
22	E55 3.30	49.5	23	E55 3.30	49.5	23	F55 2.00	30.0	40	F60 1.60	24.0	69	H63 1.60	30.0	83	H10 1.00	50.0	70	J10 0.55	35.0	115	J10 1.00	64.0	95
33	E55 3.30	49.5	23	F55 2.00	30.0	40	F60 1.60	24.0	69	H63 0.90	14.0	110	H10 0.70	11.0	160	J10 0.55	27.5	115	J10 0.55	35.0	115	J10 0.80	51.2	115
47	F55 2.00	30.0	40	F60 1.60	24.0	69	H63 0.90	14.0	110	H10 0.40	6.0	220	J10 0.50	7.5	247	K14 0.33	16.5	450	L17 0.24	15.4	650	K14 0.33	19.8	450
100	H63 0.90	14.0	110	H63 0.90	14.0	110	H10 0.40	6.0	220	H10 0.40	6.0	220	J10 0.50	7.5	247	K14 0.33	16.5	450	L17 0.24	15.4	650	M17 0.16	10.2	950
220	H10 0.40	6.0	220	H10 0.40	6.0	220	J10 0.30	4.5	296	J10 0.30	4.5	296	K14 0.23	3.5	550	L17 0.24	12.0	650						
330	J10 0.30	4.5	296	J10 0.30	4.5	296	K14 0.14	2.1	750	K14 0.14	2.1	750	L17 0.15	2.3	850	L17 0.24	12.0	650						
470	J10 0.30	4.5	296	K14 0.14	2.1	750	L17 0.10	1.5	1,000	M17 0.10	1.5	1,000	M17 0.15	2.3	920	L22 0.16	8.0	950						
1,000	K14 0.14	2.1	750	M17 0.10	1.5	1,200	M22 0.058	0.87	1,550															
2,200	L17 0.10	1.5	1,000																					
3,300	M17 0.10	1.5	1,200																					
4,700	M22 0.058	0.87	1,550																					

↑ Rated Ripple Current (mA_{RMS}/125°C, 100kHz)
 ↑ ESR (Ω max./-40°C, 100kHz)
 ↑ ESR (Ω max./20°C, 100kHz)
 ↑ Case code

V _{Dc} / μF	160		200		250		400	
2.2							J10	26
3.3							J10	37
4.7							K14	70
10	K14	100	K14	100	L17	120	L22	140
22	L17	180	L17	180	M17	205		
33	M17	245	M17	245	M22	260		
47	M22	315	M22	315				
68	M22	380						

↑ Rated Ripple Current (mA_{RMS}/125°C, 120Hz)
 ↑ Case code

CLX Series

• 125°C 2,000~4000Hrs assured.

- Vertical SMD type.
- Wide Temp., Low ESR.
- Suitable to fit for automotive equipment.
- RoHS compliant.
- Halogen-free capacitors are also available.

• AEC-Q200 compliant : Please contact us for more details, test data, information.

Solvent-proof

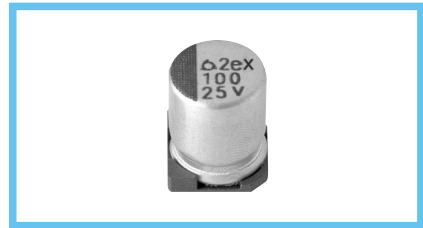
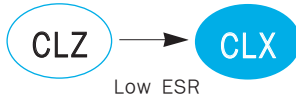

SPECIFICATIONS

Item	Characteristics															
Rated Voltage Range	10 ~ 50 V _{DC}															
Operating Temperature Range	-40 ~ +125 °C															
Capacitance Tolerance	±20%(M)															
Leakage Current	I = 0.01CV(μA) or 3μA, whichever is greater. Where, I:Max. Leakage current(μA), C:Nominal capacitance(μF), V:Rated voltage(V _{DC}) (at 20°C, 2 minutes)															
Dissipation Factor(Tan δ)	<table border="1" style="width: 100%; border-collapse: collapse; text-align: center;"> <tr> <td style="text-align: left;">Rated voltage(V_{DC})</td> <td>10</td> <td>16</td> <td>25</td> <td>35</td> <td>50</td> </tr> <tr> <td style="text-align: left;">Tan δ(Max.)</td> <td>0.24</td> <td>0.20</td> <td>0.16</td> <td>0.14</td> <td>0.16</td> </tr> </table> <p style="text-align: right;">(at 20°C, 120Hz)</p>	Rated voltage(V _{DC})	10	16	25	35	50	Tan δ(Max.)	0.24	0.20	0.16	0.14	0.16			
Rated voltage(V _{DC})	10	16	25	35	50											
Tan δ(Max.)	0.24	0.20	0.16	0.14	0.16											
Temperature Characteristics (Max. Impedance ratio)	<table border="1" style="width: 100%; border-collapse: collapse; text-align: center;"> <tr> <td style="text-align: left;">Rated voltage(V_{DC})</td> <td>10</td> <td>16</td> <td>25</td> <td>35, 50</td> </tr> <tr> <td style="text-align: left;">Z(-25°C)/Z(+20°C)</td> <td>4</td> <td>3</td> <td>2</td> <td>2</td> </tr> <tr> <td style="text-align: left;">Z(-40°C)/Z(+20°C)</td> <td>10</td> <td>8</td> <td>6</td> <td>4</td> </tr> </table> <p style="text-align: right;">(at 120Hz)</p>	Rated voltage(V _{DC})	10	16	25	35, 50	Z(-25°C)/Z(+20°C)	4	3	2	2	Z(-40°C)/Z(+20°C)	10	8	6	4
Rated voltage(V _{DC})	10	16	25	35, 50												
Z(-25°C)/Z(+20°C)	4	3	2	2												
Z(-40°C)/Z(+20°C)	10	8	6	4												
Load Life	<p>The following specifications shall be satisfied when the capacitors are restored to 20°C after the rated voltage is applied with the following conditions. H10:2,000hours, J10:3,000hours, K14:4,000hours at 125°C.</p> <p>Capacitance change ≤ ±30% of the initial value Tan δ ≤ 300% of the initial specified value Leakage current ≤ The initial specified value</p>															
Shelf Life	<p>The following specifications shall be satisfied when the capacitors are restored to 20°C after exposing them for 1,000 hours at 125°C without voltage applied. The rated voltage shall be applied to the capacitors for a minimum of 30 minutes, at least 24 hours and not more than 48 hours before the measurements.</p> <p>Capacitance change ≤ ±30% of the initial value Tan δ ≤ 300% of the initial specified value Leakage current ≤ The initial specified value</p>															
Others	Satisfied characteristics KS C IEC 60384-4															

CLX Series

PART NUMBERING SYSTEM

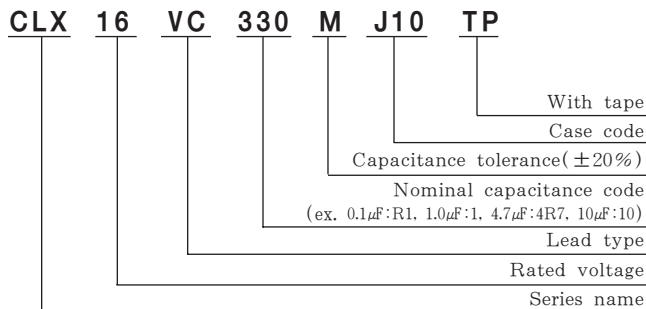

RATED RIPPLE CURRENT MULTIPLIERS

Frequency Multipliers

Size code \ Freq.(Hz)	120	1K	10K	100K
H10 ~ J10	0.93	0.97	1.00	1.00
K14	0.50	0.85	0.94	1.00

DIMENSIONS OF CLX Series

Unit(mm)

DIMENSIONS

● Vibration Resistance

<Size code: H10~K14> <Size code: H10~K14>

■ : Dummy terminals

Recommended solder land on PC board

■ : Solder land on PC board

MARKING

Case code	φ D	L	A	B	C	W	P	a	b	c	a	b	c
H10	8	10	8.3	8.3	9.0	0.7~1.1	3.1	3.1	4.2	2.2	3.1	4.2	3.5
J10	10	10	10.3	10.3	11.0	0.7~1.1	4.5	4.5	4.4	2.2	4.5	4.4	3.5
K14	12.5	13.5	13.0	13.0	13.7	1.0~1.3	4.2	4.0	5.7	2.5	3.4	6.3	9.3

● Vibration Resistance

RATINGS OF CLX Series

V _{dc} μF	10				16				25				35				50			
33																	H10	0.53	8.0	192
47													H10	0.30	4.5	264	J10	0.38	5.7	296
100									H10	0.30	4.5	264	H10	0.30	4.5	264	J10	0.38	5.7	296
220	H10	0.30	4.5	264	H10	0.30	4.5	264	J10	0.23	3.5	355	J10	0.23	3.5	355	K14	0.18	2.7	650
330	J10	0.23	3.5	355	J10	0.23	3.5	355	K14	0.11	1.7	950	K14	0.11	1.7	950				
470	J10	0.23	3.5	355	K14	0.11	1.7	950												
1,000	K14	0.11	1.7	950																

↑ Rated Ripple Current (mA rms/ 125°C, 100kHz)
 ↑ ESR (Ω max./-40°C, 100kHz)
 ↑ ESR (Ω max./20°C, 100kHz)
 ↑ Case code

CLS Series

• 125°C 2,000Hrs assured.

- Vertical SMD type.
- Wide Temp., Low ESR.
- Suitable to fit for automotive equipment.
- RoHS compliant.
- Halogen-free capacitors are also available.

• AEC-Q200 compliant : Please contact us for more details, test data, information.

Solvent-proof

CLX

→

CLS

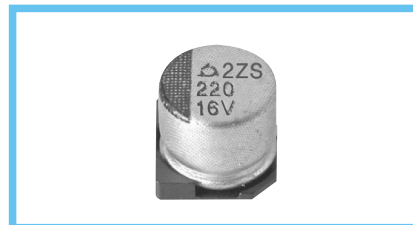

SPECIFICATIONS

Item	Characteristics																		
Rated Voltage Range	10 ~ 50 V _{DC}																		
Operating Temperature Range	-40 ~ +125 °C																		
Capacitance Tolerance	±20%(M) (at 20°C, 120Hz)																		
Leakage Current	I = 0.01CV(μA) or 3μA, whichever is greater. Where, I:Max. Leakage current(μA) C:Nominal capacitance(μF) V:Rated voltage(V _{DC}) (at 20°C, 2 minutes)																		
Dissipation Factor(Tan δ)	<table border="1" style="width: 100%; border-collapse: collapse; text-align: center;"> <tr> <td style="width: 20%;">Rated voltage(V_{DC})</td> <td>10</td> <td>16</td> <td>25</td> <td>35</td> <td>50</td> </tr> <tr> <td>Tan δ(Max.)</td> <td>0.30</td> <td>0.23</td> <td>0.18</td> <td>0.16</td> <td>0.16</td> </tr> </table> (at 20°C, 120Hz)	Rated voltage(V _{DC})	10	16	25	35	50	Tan δ(Max.)	0.30	0.23	0.18	0.16	0.16						
Rated voltage(V _{DC})	10	16	25	35	50														
Tan δ(Max.)	0.30	0.23	0.18	0.16	0.16														
Temperature Characteristics (Max. Impedance ratio)	<table border="1" style="width: 100%; border-collapse: collapse; text-align: center;"> <tr> <td style="width: 20%;">Rated voltage(V_{DC})</td> <td>10</td> <td>16</td> <td>25</td> <td>35</td> <td>50</td> </tr> <tr> <td>Z(-25°C)/Z(20°C)</td> <td>3</td> <td>2</td> <td>2</td> <td>2</td> <td>2</td> </tr> <tr> <td>Z(-40°C)/Z(20°C)</td> <td>4</td> <td>3</td> <td>3</td> <td>3</td> <td>3</td> </tr> </table> (at 120Hz)	Rated voltage(V _{DC})	10	16	25	35	50	Z(-25°C)/Z(20°C)	3	2	2	2	2	Z(-40°C)/Z(20°C)	4	3	3	3	3
Rated voltage(V _{DC})	10	16	25	35	50														
Z(-25°C)/Z(20°C)	3	2	2	2	2														
Z(-40°C)/Z(20°C)	4	3	3	3	3														
Load Life	The following specifications shall be satisfied when the capacitors are restored to 20°C after the rated voltage is applied for 2,000 hours at 125°C. Capacitance change ≤ ±30% of the initial value Tan δ ≤ 300% of the initial specified value Leakage current ≤ The initial specified value																		
Shelf Life	The following specifications shall be satisfied when the capacitors are restored to 20°C after exposing them for 1,000 hours at 125°C without voltage applied. The rated voltage shall be applied to the capacitors for a minimum of 30 minutes, at least 24 hours and not more than 48 hours before the measurements. Capacitance change ≤ ±30% of the initial value Tan δ ≤ 300% of the initial specified value Leakage current ≤ The initial specified value																		
Others	Satisfied characteristics KS C IEC 60384-4																		

CLS Series

PART NUMBERING SYSTEM

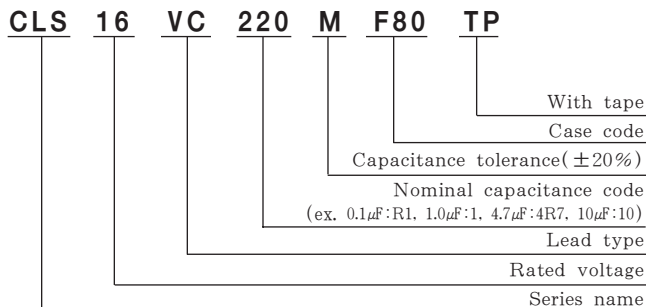

RATED RIPPLE CURRENT MULTIPLIERS

Frequency Multipliers

Cap.(μF)	Freq.(Hz)			
	120	1K	10K	100K
47 ~ 150	0.40	0.75	0.90	1.00
220 ~ 470	0.50	0.85	0.94	1.00

DIMENSIONS OF CLS Series

Unit(mm)

DIMENSIONS

● Vibration Resistance

<Size code: F80~J10> <Size code: H10~J10>

■: Dummy terminals

Recommended solder land on PC board

■: Solder land on PC board

MARKING

Note 1 : L±0.5 for 8×10(H10)~10×10(J10)

Case code	∅D	L	A	B	C	W	P	a	b	c	a	b	c
F80	6.3	7.7	6.6	6.6	7.2	0.5~0.8	1.9	1.9	3.5	1.6			
H10	8	10	8.3	8.3	9.0	0.7~1.1	3.1	3.1	4.2	2.2	3.1	4.2	3.5
J10	10	10	10.3	10.3	11.0	0.7~1.1	4.5	4.5	4.4	2.2	4.5	4.4	3.5

● Vibration Resistance →

RATINGS OF CLS Series

WV (Vdc)	Cap.(μF)	Case code	ESR(Ω max./100kHz)		Rated Ripple Current (mArms / 125°C, 100kHz)
			20°C	-40°C	
10	220	H10	0.150	3.0	350
	330	H10	0.150	3.0	350
		J10	0.120	2.0	550
16	470	J10	0.120	2.0	550
		F80	0.300	3.0	240
		H10	0.150	3.0	350
25	330	H10	0.150	3.0	350
	470	J10	0.120	2.0	550
		F80	0.300	3.0	240
35	47	F80	0.300	3.0	240
	68	F80	0.300	3.0	240
		F80	0.300	3.0	240
	100	H10	0.150	3.0	350
50	220	J10	0.120	2.0	550
	100	H10	0.360	5.4	320
		150	J10	0.300	4.5

CLU Series

• 125°C 3000~5,000Hrs assured.

- Vertical SMD type.
- Wide Temp. Low ESR, Long Life
- Suitable to fit for automotive equipment.
- RoHS compliant.
- Halogen-free capacitors are also available.

• AEC-Q200 compliant : Please contact us for more details, test data, information.

Solvent-proof

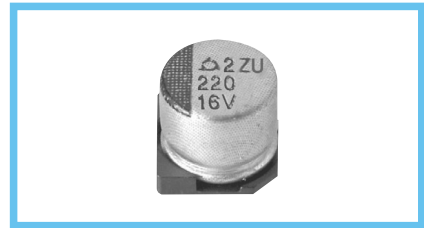
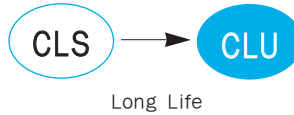

SPECIFICATIONS

Item	Characteristics																		
Rated Voltage Range	10 ~ 50 V _{DC}																		
Operating Temperature Range	-40 ~ +125 °C																		
Capacitance Tolerance	±20%(M) (at 20°C, 120Hz)																		
Leakage Current	I = 0.01CV(μA) or 3μA, whichever is greater. Where, I:Max. Leakage current(μA) C:Nominal capacitance(μF) V:Rated voltage(V _{DC}) (at 20°C, 2 minutes)																		
Dissipation Factor(Tan δ)	<table border="1" style="width: 100%; border-collapse: collapse; text-align: center;"> <tr> <td style="text-align: left;">Rated voltage(V_{DC})</td> <td>10</td> <td>16</td> <td>25</td> <td>35</td> <td>50</td> </tr> <tr> <td style="text-align: left;">Tan δ(Max.)</td> <td>0.30</td> <td>0.23</td> <td>0.18</td> <td>0.16</td> <td>0.16</td> </tr> </table> (at 20°C, 120Hz)	Rated voltage(V _{DC})	10	16	25	35	50	Tan δ(Max.)	0.30	0.23	0.18	0.16	0.16						
Rated voltage(V _{DC})	10	16	25	35	50														
Tan δ(Max.)	0.30	0.23	0.18	0.16	0.16														
Temperature Characteristics (Max. Impedance ratio)	<table border="1" style="width: 100%; border-collapse: collapse; text-align: center;"> <tr> <td style="text-align: left;">Rated voltage(V_{DC})</td> <td>10</td> <td>16</td> <td>25</td> <td>35</td> <td>50</td> </tr> <tr> <td style="text-align: left;">Z(-25°C)/Z(20°C)</td> <td>3</td> <td>2</td> <td>2</td> <td>2</td> <td>2</td> </tr> <tr> <td style="text-align: left;">Z(-40°C)/Z(20°C)</td> <td>4</td> <td>3</td> <td>3</td> <td>3</td> <td>3</td> </tr> </table> (at 120Hz)	Rated voltage(V _{DC})	10	16	25	35	50	Z(-25°C)/Z(20°C)	3	2	2	2	2	Z(-40°C)/Z(20°C)	4	3	3	3	3
Rated voltage(V _{DC})	10	16	25	35	50														
Z(-25°C)/Z(20°C)	3	2	2	2	2														
Z(-40°C)/Z(20°C)	4	3	3	3	3														
Load Life	The following specifications shall be satisfied when the capacitors are restored to 20°C after the rated voltage is applied for 5,000hours(3,000hours for F80 size) at 125°C. Capacitance change ≤ ±30% of the initial value Tan δ ≤ 300% of the initial specified value Leakage current ≤ The initial specified value																		
Shelf Life	The following specifications shall be satisfied when the capacitors are restored to 20°C after exposing them for 1,000 hours at 125°C without voltage applied. The rated volage shall be applied to the capacitors for a minimum of 30 minutes, at least 24 hours and not more than 48 hours before the measurements. Capacitance change ≤ ±30% of the initial value Tan δ ≤ 300% of the initial specified value Leakage current ≤ The initial specified value																		
Others	Satisfied characteristics KS C IEC 60384-4																		

CLU Series

PART NUMBERING SYSTEM

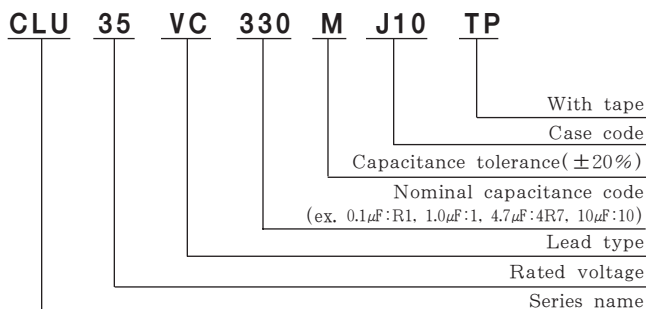

RATED RIPPLE CURRENT MULTIPLIERS

Frequency Multipliers

Cap.(μF)	Freq.(Hz)			
	120	1K	10K	100K
47 ~ 100	0.40	0.75	0.90	1.00
220 ~ 680	0.50	0.85	0.94	1.00

DIMENSIONS OF CLU Series

Unit(mm)

DIMENSIONS

● Vibration Resistance

<Size code:F80~J10> <Size code:F80~J10>

●: Dummy terminals

Recommended solder land on PC board

■: Solder land on PC board

MARKING

Note 1 : L±0.5 for H10 , J10

Case code	∅D	L	A	B	C	W	P	a	b	c	a	b	c
F80	6.3	7.7	6.6	6.6	7.2	0.5~0.8	1.9	1.9	3.5	1.6			
H10	8	10	8.3	8.3	9.0	0.7~1.1	3.1	3.1	4.2	2.2	3.1	4.2	3.5
J10	10	10	10.3	10.3	11.0	0.7~1.1	4.5	4.5	4.4	2.2	4.5	4.4	3.5

● Vibration Resistance →

RATINGS OF CLU Series

Vdc	Cap.(μ F)	Case Code	ESR (Ω max./20°C,100kHz)	Rated Ripple Current (mA rms/105°C,100kHz)
10	220	F80	0.30	240
	470	H10	0.20	350
	680	J10	0.15	550
16	220	F80	0.30	240
	330	H10	0.20	350
	680	J10	0.15	550
25	100	F80	0.30	240
	220	H10	0.20	350
	330	J10	0.15	550
35	100	F80	0.30	240
	220	H10	0.20	350
	330	J10	0.15	550
50	47	F80	0.50	190
	150	H10	0.30	320
	220	J10	0.20	500

VDA Series

• 150°C 1,000Hrs assured.

- Vertical SMD type.
- Wide Temperature range.
- Suitable to fit for automotive equipment.
- Ecological capacitors are also available.
- Halogen-free capacitors are also available.

Solvent-proof

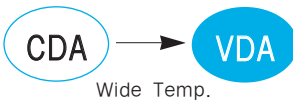

SPECIFICATIONS

Item	Characteristics																		
Rated Voltage Range	10 ~ 50 V _{DC}																		
Operating Temperature Range	-40 ~ +150 °C																		
Capacitance Tolerance	±20%(M) (at 20°C, 120Hz)																		
Leakage Current	I = 0.01CV(μA) or 3μA, whichever is greater. Where, I: Max. Leakage current(μA) C: Nominal capacitance(μF) V: Rated voltage(V _{DC}) (at 20°C, 2 minutes)																		
Dissipation Factor(Tan δ)	<table border="1" style="width: 100%; border-collapse: collapse; text-align: center;"> <tr> <td style="width: 20%;">Rated voltage(V_{DC})</td> <td>10</td> <td>16</td> <td>25</td> <td>35</td> <td>50</td> </tr> <tr> <td>Tan δ(Max.)</td> <td>0.24</td> <td>0.20</td> <td>0.16</td> <td>0.14</td> <td>0.14</td> </tr> </table> (at 20°C, 120Hz)	Rated voltage(V _{DC})	10	16	25	35	50	Tan δ(Max.)	0.24	0.20	0.16	0.14	0.14						
Rated voltage(V _{DC})	10	16	25	35	50														
Tan δ(Max.)	0.24	0.20	0.16	0.14	0.14														
Temperature Characteristics (Max. Impedance ratio)	<table border="1" style="width: 100%; border-collapse: collapse; text-align: center;"> <tr> <td style="width: 20%;">Rated voltage(V_{DC})</td> <td>10</td> <td>16</td> <td>25</td> <td>35</td> <td>50</td> </tr> <tr> <td>Z(-25°C)/Z(+20°C)</td> <td>6</td> <td>4</td> <td>3</td> <td>2</td> <td>2</td> </tr> <tr> <td>Z(-40°C)/Z(+20°C)</td> <td>12</td> <td>10</td> <td>8</td> <td>6</td> <td>6</td> </tr> </table> (at 120Hz)	Rated voltage(V _{DC})	10	16	25	35	50	Z(-25°C)/Z(+20°C)	6	4	3	2	2	Z(-40°C)/Z(+20°C)	12	10	8	6	6
Rated voltage(V _{DC})	10	16	25	35	50														
Z(-25°C)/Z(+20°C)	6	4	3	2	2														
Z(-40°C)/Z(+20°C)	12	10	8	6	6														
Load Life	The following specifications shall be satisfied when the capacitors are restored to 20°C after the rated voltage is applied for 1,000 hours at 150°C. Capacitance change ≤ ±30% of the initial value Tan δ ≤ 300% of the initial specified value Leakage current ≤ The initial specified value																		
Shelf Life	The following specifications shall be satisfied when the capacitors are restored to 20°C after exposing them for 1,000 hours at 150°C without voltage applied. The rated voltage shall be applied to the capacitors for a minimum of 30 minutes, at least 24 hours and not more than 48 hours before the measurements. Capacitance change ≤ ±30% of the initial value Tan δ ≤ 300% of the initial specified value Leakage current ≤ The initial specified value																		
Others	Satisfied characteristics KS C IEC 60384-4																		

VDA Series

PART NUMBERING SYSTEM

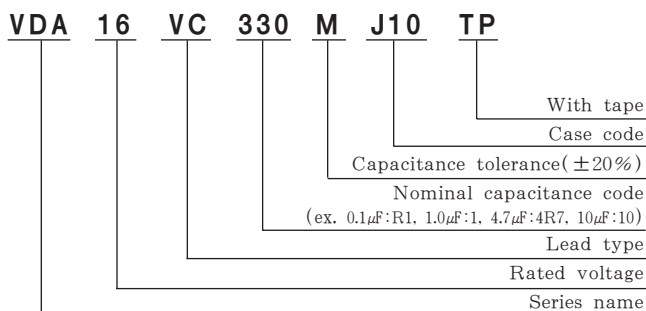

RATED RIPPLE CURRENT MULTIPLIERS

Frequency Multipliers

Freq.(Hz)	120	1K	10K	100K
Factor	1.00	1.36	1.50	1.50

DIMENSIONS OF VDA Series

Unit(mm)

DIMENSIONS

● Vibration Resistance

<Size code: J10~K14> <Size code: J10~K14>

■ : Dummy terminals

Recommended solder land on PC board

■ : Solder land on PC board

MARKING

Case code	φ D	L	A	B	C	W	P	a	b	c	a	b	c
J10	10	10	10.3	10.3	11.0	0.7~1.1	4.5	4.5	4.4	2.2	4.5	4.4	3.5
K14	12.5	13.5	13.0	13.0	13.7	1.0~1.3	4.2	4.0	5.7	2.5	3.4	6.3	9.3

● Vibration Resistance →

RATINGS OF VDA Series

V _{DC} / μF	10	16	25	35	50
47				J10 90	J10 90
100			J10 123	J10 132	K14 167
220		J10 163	J10 183	K14 249	
330	J10 183	J10 200	K14 285		
470	J10 218	K14 304			
1,000	K14 405				

↑ ↑

Rated Ripple Current (mArms/150°C, 120Hz)

Case code

MVG(MV)-BP Series

• 85°C 2,000Hrs assured.

- Vertical SMD type.
- Bi-polarized.
- For LED MT / TV.
- RoHS compliant.
- Halogen-free capacitors are also available.

BDS(MVK)-BP Series

• 105°C 1,000Hrs assured.

- Vertical SMD type.
- Bi-polarized.
- Wide Temperature Range.
- For LED MT / TV.
- RoHS compliant.
- Halogen-free capacitors are also available.

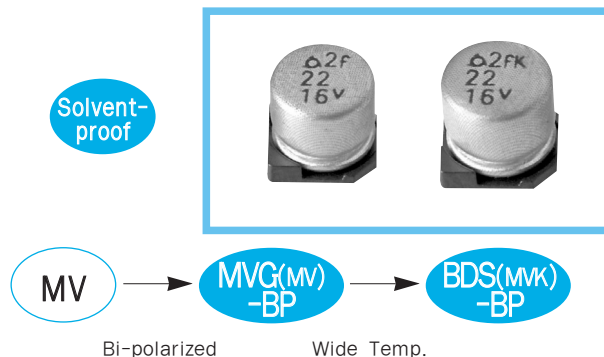

SPECIFICATIONS

Item	Characteristics																						
	MVG(MV)-BP	BDS(MVK)-BP																					
Series Name	MVG(MV)-BP	BDS(MVK)-BP																					
Rated Voltage Range	4 ~ 50 V _{DC}	6.3 ~ 50 V _{DC}																					
Operating Temperature Range	-40 ~ +85°C	-40 ~ +105°C																					
Capacitance Tolerance	±20%(M) (at 20°C, 120Hz)																						
Leakage Current (In both directions)	I=0.05CV(μA) or 10μA, whichever is greater. Where, I:Max. Leakage current(μA), C:Nominal capacitance(μF), V:Rated voltage(V _{DC}) (at 20°C, after 2 minutes)																						
Dissipation Factor(Tanδ)	<table border="1" style="width: 100%; text-align: center;"> <tr> <td>Rated Voltage(V_{DC})</td> <td>4</td> <td>6.3</td> <td>10</td> <td>16</td> <td>25</td> <td>35~50</td> </tr> <tr> <td>MV-BP</td> <td>0.45</td> <td>0.32</td> <td>0.26</td> <td>0.24</td> <td>0.22</td> <td>0.20</td> </tr> <tr> <td>MVK-BP</td> <td>-</td> <td>0.35</td> <td>0.26</td> <td>0.24</td> <td>0.20</td> <td>0.18</td> </tr> </table> <p style="text-align: right;">(at 20°C, 120Hz)</p>		Rated Voltage(V _{DC})	4	6.3	10	16	25	35~50	MV-BP	0.45	0.32	0.26	0.24	0.22	0.20	MVK-BP	-	0.35	0.26	0.24	0.20	0.18
Rated Voltage(V _{DC})	4	6.3	10	16	25	35~50																	
MV-BP	0.45	0.32	0.26	0.24	0.22	0.20																	
MVK-BP	-	0.35	0.26	0.24	0.20	0.18																	
Temperature Characteristics (Max. Impedance ratio)	<table border="1" style="width: 100%; text-align: center;"> <tr> <td>Rated Voltage(V_{DC})</td> <td>4</td> <td>6.3</td> <td>10</td> <td>16</td> <td>25</td> <td>35~50</td> </tr> <tr> <td>Z(-25°C)/Z(20°C)</td> <td>7</td> <td>4</td> <td>3</td> <td>2</td> <td>2</td> <td>2</td> </tr> <tr> <td>Z(-40°C)/Z(20°C)</td> <td>15</td> <td>10</td> <td>8</td> <td>6</td> <td>4</td> <td>3</td> </tr> </table> <p style="text-align: right;">(at 120Hz)</p>		Rated Voltage(V _{DC})	4	6.3	10	16	25	35~50	Z(-25°C)/Z(20°C)	7	4	3	2	2	2	Z(-40°C)/Z(20°C)	15	10	8	6	4	3
Rated Voltage(V _{DC})	4	6.3	10	16	25	35~50																	
Z(-25°C)/Z(20°C)	7	4	3	2	2	2																	
Z(-40°C)/Z(20°C)	15	10	8	6	4	3																	
Load Life	<p>The following specifications shall be satisfied when the capacitors are restored to 20°C after the rated voltage is applied with the following conditions with its polarization reversed every 250 hours.</p> <table border="1" style="width: 100%; text-align: center;"> <thead> <tr> <th>Series Name</th> <th>MVG(MV)-BP</th> <th>BDS(MVK)-BP</th> </tr> </thead> <tbody> <tr> <td>Test time & temperature</td> <td>2,000 hours at 85°C</td> <td>1,000 hours at 105°C</td> </tr> <tr> <td>Capacitance change</td> <td>≤ ±20% of the initial value</td> <td>≤ ±30% of the initial value</td> </tr> <tr> <td>Tanδ</td> <td>≤200% of the initial specified value</td> <td>≤300% of the initial specified value</td> </tr> <tr> <td>Leakage current</td> <td>≤The initial specified value</td> <td>≤The initial specified value</td> </tr> </tbody> </table>		Series Name	MVG(MV)-BP	BDS(MVK)-BP	Test time & temperature	2,000 hours at 85°C	1,000 hours at 105°C	Capacitance change	≤ ±20% of the initial value	≤ ±30% of the initial value	Tanδ	≤200% of the initial specified value	≤300% of the initial specified value	Leakage current	≤The initial specified value	≤The initial specified value						
Series Name	MVG(MV)-BP	BDS(MVK)-BP																					
Test time & temperature	2,000 hours at 85°C	1,000 hours at 105°C																					
Capacitance change	≤ ±20% of the initial value	≤ ±30% of the initial value																					
Tanδ	≤200% of the initial specified value	≤300% of the initial specified value																					
Leakage current	≤The initial specified value	≤The initial specified value																					
Shelf Life	<p>The following specifications shall be satisfied when the capacitors are restored to 20°C after exposing them for 500 hours at 85°C (MVG(MV)-BP) or 105°C (BDS(MVK)-BP) without voltage applied. The rated voltage shall be applied to the capacitors for a minimum of 30 minutes, at least 24 hours and not more than 48 hours before the measurements.</p> <table border="1" style="width: 100%; text-align: center;"> <thead> <tr> <th>Series Name</th> <th>MVG(MV)-BP</th> <th>BDS(MVK)-BP</th> </tr> </thead> <tbody> <tr> <td>Capacitance change</td> <td>≤ ±15% of the initial value</td> <td>≤ ±25% of the initial value</td> </tr> <tr> <td>Tanδ</td> <td>≤150% of the initial specified value</td> <td>≤200% of the initial specified value</td> </tr> <tr> <td>Leakage current</td> <td>≤The initial specified value</td> <td>≤The initial specified value</td> </tr> </tbody> </table>		Series Name	MVG(MV)-BP	BDS(MVK)-BP	Capacitance change	≤ ±15% of the initial value	≤ ±25% of the initial value	Tanδ	≤150% of the initial specified value	≤200% of the initial specified value	Leakage current	≤The initial specified value	≤The initial specified value									
Series Name	MVG(MV)-BP	BDS(MVK)-BP																					
Capacitance change	≤ ±15% of the initial value	≤ ±25% of the initial value																					
Tanδ	≤150% of the initial specified value	≤200% of the initial specified value																					
Leakage current	≤The initial specified value	≤The initial specified value																					
Others	Satisfied characteristics KS C IEC 60384-4																						

MVG(MV)-BP / BDS(MVK)-BP Series

PART NUMBERING SYSTEM

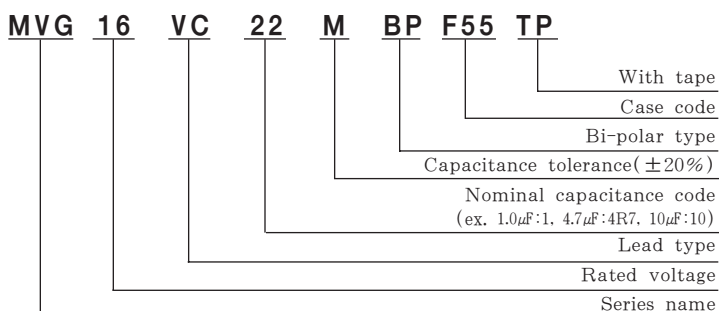

PRECAUTIONS TO USERS

Soldering method

The capacitors of Alchip have no capability to withstand such dip or wave soldering as totally immerses a components into a solder bath.

Reflow soldering

Use the capacitors within the Recommended Reflow Soldering Conditions, and also make sure to check the temperature stress to the capacitors because the following makes a difference in the stress to the capacitors. If any other reflow soldering conditions are applied, please consult us.

- ① Location of components. (The edge sides of a PC board increases its temperature more than the center does.)
- ② Population of components. The less the component population is the more the temperature is increased.
- ③ Material of printed circuit board. As a ceramic board needs heating up more than a glass epoxy board to reach the same board temperature, the capacitors may be damaged.
- ④ Thickness of PC board. A thick PC board needs heating up more than a thin board. It may damage the capacitors.
- ⑤ Size of PC board. A large PC board needs heating up more than a small board, and it may damage the capacitors.
- ⑥ Location of infrared ray lamps. On IR reflow as well as hot plate reflow, heating only the reverse side of the PC board will reduce a stress to the capacitors.

Rework of soldering

Avoid soldering more than once by reflow. Use a soldering iron for rework of solder, and do not exceed an iron tip temperature of 300°C and a max. exposure time of 5 seconds.

Mechanical stress

Do not lift up or push the capacitor after soldering. Avoid curvature of the PC board. These may damage the capacitor.

Cleaning of assembly board

For the cleaning conditions, see page 46~47.

Immediately after solvent cleaning, evaporate a residual solvent for at least 10 minutes with a hot forced air. If the assembly board is inadequately dried after a washing process, the capacitors will keep suffering from a residual solvent for long periods of time, and will be corroded while in service.

Coating on assembly board

- ① Before coating, evaporate cleaning solvents from the assembly board.
- ② Before the conformal coating, using a buffer pre-coat which does not contain chloride is recommended to reduce stress to the capacitors.

Molding by resin

Inner pressure of a capacitor slowly increases over the service life of the capacitor with gas being produced by internal chemical reaction. If the end seal of the capacitor is completely be in danger. Also if the resin contains a large amount of chlorine ion, it will penetrate into the end seal, get into the inside element of the capacitor, and damage the capacitor while in service.

Others

The Precautions to Users for Aluminum Electrolytic Capacitors shall be applied. (page 44)

RECOMMENDED PB-FREE REFLOW SOLDERING CONDITIONS

The following conditions are recommended for air or infrared reflow soldering of the surface mount capacitors onto a glass epoxy circuit board of 90 × 50 × 0.8mm (with resist) by cream solder (eutectic solder) . The temperatures shown are the surface temperature values of the top of the capacitor.

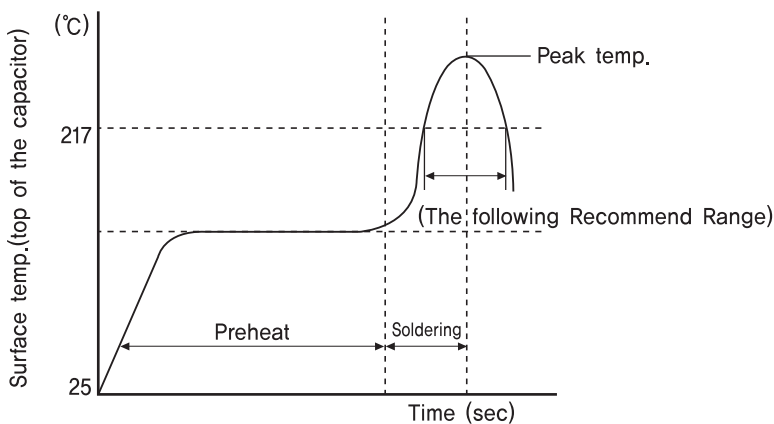

TEMPERATURE PROFILE

CASE CODE	Time of Preheat temp. (from 150°C to 200°C)	Time to be Maintained Above 217°C	Time to be Maintained Above 230°C	Peak Temp.	Reflow Cycle
B55, D55, D56 E55, E56, F55, F56, F60, F80 H63, H10, J85, J10, K14	60 ~ 100 Sec	60 ~ 70 Sec	20 ~ 30 Sec	250°C (10 Sec ↓)	1 TIME
L17, L22 M17, M22	60 ~ 100 Sec	50 ~ 60 Sec	-	230°C (10 Sec ↓)	1 TIME

GSA Series

- Non-solvent proof.
- Height 7mm.
- For CAR-Audio, Tuner.

- 85°C 2,000Hrs assured.
- RoHS compliant.
- Halogen-free capacitors are also available.

GZA Series

- Solvent proof.
- Height 7mm.
- For CAR-Audio, Tuner.

- 85°C 2,000Hrs assured.
- RoHS compliant.
- Halogen-free capacitors are also available.

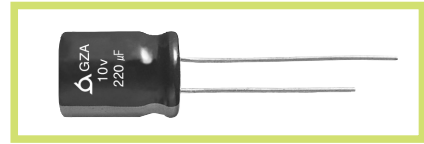
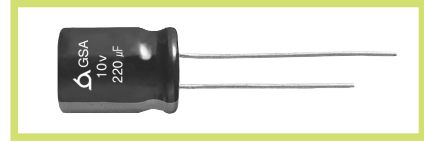
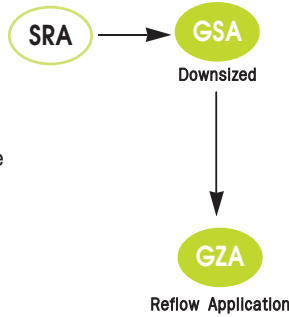

SPECIFICATIONS

Item	Characteristics																					
Rated Voltage Range	6.3 ~ 63 V _{DC}																					
Operating Temperature Range	-40 ~ +85°C																					
Capacitance Tolerance	±20%(M) (at 20°C, 120Hz)																					
Leakage Current	I = 0.01CV(μA) or 3μA, whichever is greater. where, I: Max. Leakage current(μA) C: Nominal capacitance(μF), V: Rated voltage(V _{DC}) (at 20°C, 2 minutes)																					
Dissipation Factor(Tanδ)	<table border="1"> <tr> <td>Rated Voltage(V_{DC})</td> <td>6.3</td> <td>10</td> <td>16</td> <td>25</td> <td>35</td> <td>50</td> <td>63</td> </tr> <tr> <td>Tanδ(Max.)</td> <td>0.24</td> <td>0.20</td> <td>0.16</td> <td>0.14</td> <td>0.12</td> <td>0.11</td> <td>0.08</td> </tr> </table> ※ 6.3 VB 220(0.27) , 16 VB 100(0.19) (at 20°C, 120Hz)	Rated Voltage(V _{DC})	6.3	10	16	25	35	50	63	Tanδ(Max.)	0.24	0.20	0.16	0.14	0.12	0.11	0.08					
Rated Voltage(V _{DC})	6.3	10	16	25	35	50	63															
Tanδ(Max.)	0.24	0.20	0.16	0.14	0.12	0.11	0.08															
Temperature Characteristics (Max. Impedance ratio)	<table border="1"> <tr> <td>Rated Voltage(V_{DC})</td> <td>6.3</td> <td>10</td> <td>16</td> <td>25</td> <td>35</td> <td>50~63</td> </tr> <tr> <td>Z(-25°C)/Z(+20°C)</td> <td>4</td> <td>3</td> <td>2</td> <td>2</td> <td>2</td> <td>2</td> </tr> <tr> <td>Z(-40°C)/Z(+20°C)</td> <td>8</td> <td>6</td> <td>4</td> <td>3</td> <td>3</td> <td>4</td> </tr> </table> (at 120Hz)	Rated Voltage(V _{DC})	6.3	10	16	25	35	50~63	Z(-25°C)/Z(+20°C)	4	3	2	2	2	2	Z(-40°C)/Z(+20°C)	8	6	4	3	3	4
Rated Voltage(V _{DC})	6.3	10	16	25	35	50~63																
Z(-25°C)/Z(+20°C)	4	3	2	2	2	2																
Z(-40°C)/Z(+20°C)	8	6	4	3	3	4																
Load Life	The following specifications shall be satisfied when the capacitors are restored to 20°C after the rated voltage is applied for 2,000 hours at 85°C. Capacitance change ≦ ±25% of the initial value (where, ±20% for GZA Series) Tanδ ≦ 200% of the initial specified value Leakage current ≦ The initial specified value																					
Shelf Life	The following specifications shall be satisfied when the capacitors are restored to 20°C after exposing them for 1,000 hours at 85°C without voltage applied. The rated voltage shall be applied to the capacitors for a minimum of 30 minutes, at least 24 hours and not more than 48 hours before the measurements. Capacitance change ≦ ±20% of the initial value Tanδ ≦ 200% of the initial specified value Leakage current ≦ 200% of initial specified value																					
Others	Satisfied characteristics KS C IEC 60384-4																					

DIMENSIONS OF GSA/GZA Series

Unit(mm)

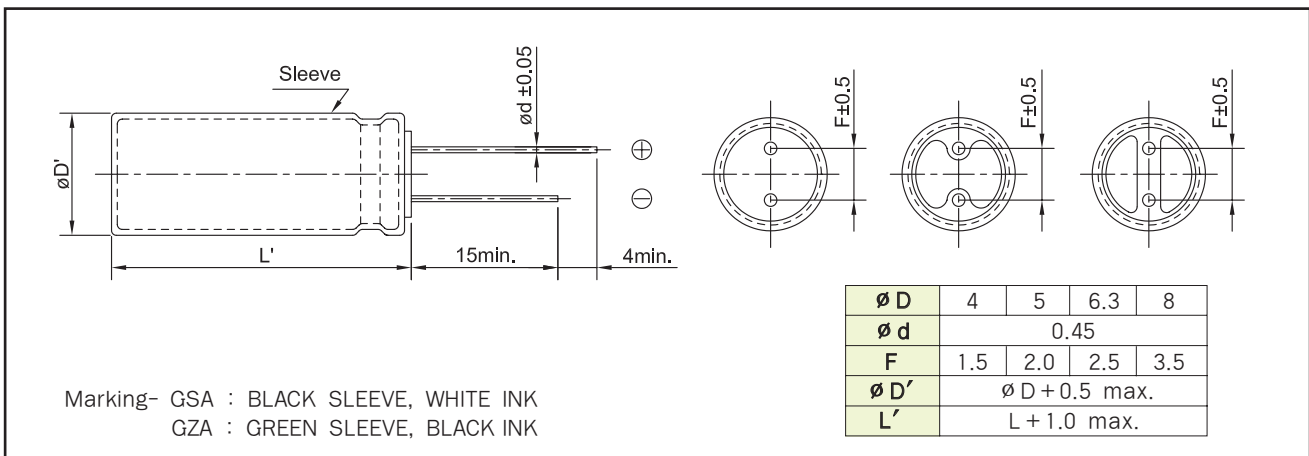

RATINGS OF GSA / GZA Series

μF \ V _{DC}	6.3	10	16	25	35	50	63	
0.1						4×7 1.3	4×7 1.3	
0.15						4×7 2.0	4×7 2.0	
0.22						4×7 2.9	4×7 3.0	
0.33						4×7 3.5	4×7 3.7	
0.47						4×7 5.0	4×7 5.4	
0.68						4×7 7.1	4×7 7.6	
1						4×7 10	4×7 11	
1.5						4×7 12	4×7 13	
2.2						4×7 15	4×7 17	
3.3					4×7 17	4×7 18	4×7 20	
4.7				4×7 19	4×7 20	4×7 22	4×7 25	
6.8				4×7 20	4×7 23	5×7 25	5×7 28	
10			4×7 25	4×7 26	4×7 27	5×7 31	6.3×7 38	
15			4×7 28	4×7 30	5×7 36	6.3×7 48	6.3×7 51	
22	4×7 31	4×7 32	4×7 34	5×7 41	5×7 44	6.3×7 58	6.3×7 62	
33	4×7 35	4×7 38	5×7 45	5×7 50	6.3×7 64	6.3×7 68	8×7 72	
47	4×7 42	5×7 50	5×7 55	6.3×7 65	6.3×7 70	8×7 84		
68	4×7 56	5×7 60	6.3×7 83	6.3×7 85	8×7 91			
100	5×7 68	6.3×7 80	6.3×7 95	6.3×7 101				
150	6.3×7 90	6.3×7 95	8×7 116	8×7 127				
220	6.3×7 120	6.3×7 122	8×7 140					
330	6.3×7 141	8×7 152						
470	8×7 168	← Case Size $\phi D \times L$ (mm)						
		← Rated Ripple Current (mArms/85°C, 120Hz)						

RECOMMENDED REFLOW SOLDERING CONDITIONS(For GZA Series)

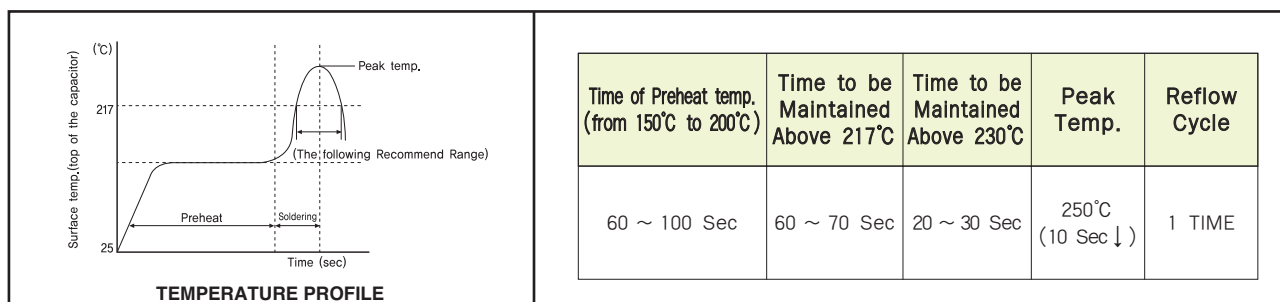

HMA Series

• 105°C 2,000Hrs assured.

- Height 7mm.
- Wide Temperature range.
- Long Life.
- For CAR-Audio, Tuner.
- RoHS compliant.
- Halogen-free capacitors are also available.

Solvent-proof

HSA
(KMA)

Long Life

HMA

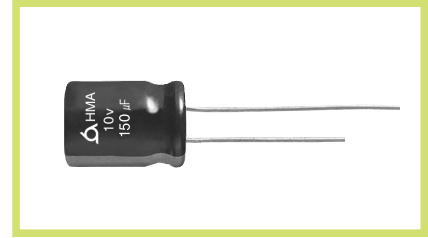

SPECIFICATIONS

Item	Characteristics															
Rated Voltage Range	6.3 ~ 50 V _{DC}															
Operating Temperature Range	-55 ~ +105°C															
Capacitance Tolerance	±20%(M) (at 20°C, 120Hz)															
Leakage Current	I = 0.01CV(µA) or 3µA, whichever is greater. Where, I:Max. Leakage current(µA), C:Nominal capacitance(µF), V:Rated voltage(V _{DC}) (at 20°C, 2 minutes)															
Dissipation Factor(Tanδ)	<table border="1"> <tr> <td>Rated Voltage(V_{DC})</td> <td>6.3</td> <td>10</td> <td>16</td> <td>25</td> <td>35</td> <td>50</td> </tr> <tr> <td>Tanδ(Max.)</td> <td>0.22</td> <td>0.19</td> <td>0.16</td> <td>0.14</td> <td>0.12</td> <td>0.10</td> </tr> </table> (at 20°C, 120Hz)	Rated Voltage(V _{DC})	6.3	10	16	25	35	50	Tanδ(Max.)	0.22	0.19	0.16	0.14	0.12	0.10	
Rated Voltage(V _{DC})	6.3	10	16	25	35	50										
Tanδ(Max.)	0.22	0.19	0.16	0.14	0.12	0.10										
Temperature Characteristics (Max. Impedance ratio)	<table border="1"> <tr> <td>Rated Voltage(V_{DC})</td> <td>6.3</td> <td>10</td> <td>16</td> <td>25~50</td> </tr> <tr> <td>Z(-25°C)/Z(+20°C)</td> <td>4</td> <td>3</td> <td>2</td> <td>2</td> </tr> <tr> <td>Z(-40°C)/Z(+20°C)</td> <td>8</td> <td>6</td> <td>6</td> <td>3</td> </tr> </table> (at 120Hz)	Rated Voltage(V _{DC})	6.3	10	16	25~50	Z(-25°C)/Z(+20°C)	4	3	2	2	Z(-40°C)/Z(+20°C)	8	6	6	3
Rated Voltage(V _{DC})	6.3	10	16	25~50												
Z(-25°C)/Z(+20°C)	4	3	2	2												
Z(-40°C)/Z(+20°C)	8	6	6	3												
Load Life	The following specifications shall be satisfied when the capacitors are restored to 20°C after the rated voltage is applied for 2,000 hours at 105°C. Capacitance change ≤ ±20% of the initial value(when, ±25% for 6.3 V _{DC} ~16 V _{DC}) Tan δ ≤ 200% of the initial specified value Leakage current ≤ The initial specified value															
Shelf Life	The following specifications shall be satisfied when the capacitors are restored to 20°C after exposing them for 1,000 hours at 105°C without voltage applied.The rated voltage shall be applied to the capacitors for a minimum of 30 minutes, at least 24 hours and not more than 48 hours before the measurements. Capacitance change ≤ ±20% of initial value(when, ±25% for 6.3 V _{DC} ~16 V _{DC}) Tan δ ≤ 200% of initial specified value Leakage current ≤ 200% of initial specified value															
Others	Satisfied characteristics KS C IEC 60384-4															

RATINGS OF HMA Series

V _{DC} µF	6.3	10	16	25	35	50
0.1						4×7 1.3
0.15						4×7 2.0
0.22						4×7 2.9
0.33						4×7 3.5
0.47						4×7 5.0
0.68						4×7 7.1
1						4×7 10
1.5						4×7 12
2.2						4×7 15
3.3					4×7 17	4×7 18
4.7				4×7 19	4×7 20	5×7 23
6.8			4×7 20	5×7 23	5×7 24	6.3×7 28
10			4×7 25	5×7 28	4×7 23	6.3×7 34
15		4×7 28	5×7 31	6.3×7 35	6.3×7 37	6.3×7 41
22	4×7 31	5×7 35	5×7 39	6.3×7 43	6.3×7 47	6.3×7 52
33	5×7 39	5×7 43	6.3×7 49	6.3×7 53	8×7 62	8×7 68
47	5×7 47	6.3×7 53	6.3×7 59	8×7 68		
68	6.3×7 57	6.3×7 63	8×7 76			
100	6.3×7 71	6.3×7 80				
150	8×7 94	8×7 94				

↑ Rated Ripple Current (mA rms/105°C, 120Hz)
 ↑ Case Size ØD×L(mm)

DIMENSIONS OF HMA Series

Unit(mm)

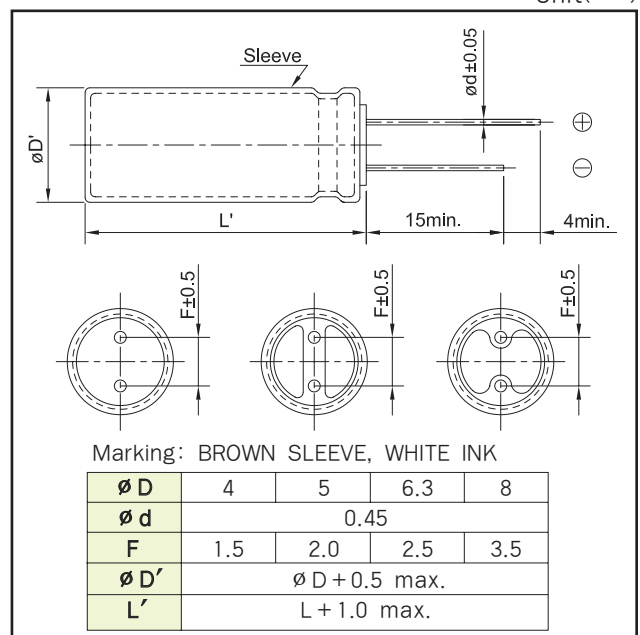

HXB Series

• 105°C 1,000~2,000Hrs assured.

- Non-solvent proof.
- Low Impedance, Long Life.
- Height 7mm~9mm.
- For LED TV PSU, DVD Driver.
- RoHS compliant.
- Halogen-free capacitors are also available.

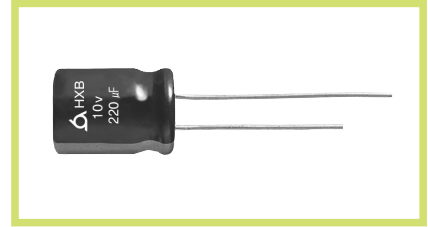
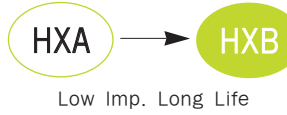

SPECIFICATIONS

Item	Characteristics
Rated Voltage Range	6.3 ~ 50 V _{DC}
Operating Temperature Range	-40 ~ +105°C
Capacitance Tolerance	±20%(M) (at 20°C, 120Hz)
Leakage Current	I=0.01CV(µA) or 3µA, whichever is greater. Where, I:Max. Leakage current(µA), C:Nominal capacitance(µF), V:Rated voltage(V _{DC}) (at 20°C, 2 minutes)
Dissipation Factor(Tanδ)	Rated voltage(V _{DC})
	Tanδ(Max.)
Temperature Characteristics (Max. Impedance ratio)	Rated voltage(V _{DC})
	Z(-25°C)/Z(20°C)
	Z(-40°C)/Z(20°C)
Load Life	The following specifications shall be satisfied when the capacitors are restored to 20°C after the rated voltage is applied for 2,000 hours at 105°C. (where 1,000 hours for ø4) Capacitance change ≤ ±25% of the initial value Tanδ ≤ 200% of the initial specified value Leakage current ≤ The initial specified value
Shelf Life	The following specifications shall be satisfied when the capacitors are restored to 20°C after exposing them for 1,000 hours at 105°C without voltage applied. The rated voltage shall be applied to the capacitors for a minimum of 30 minutes, at least 24 hours and not more than 48 hours before the measurements. Capacitance change ≤ ±25% of the initial value Tanδ ≤ 200% of the initial specified value Leakage current ≤ The initial specified value
Others	Satisfied characteristics KS C IEC 60384-4

RATINGS OF HXB Series

V _{DC} µF	6.3		10		16		25		35		50	
1											4X7 3.00 53	
2.2											5X7 2.20 80	
4.7											4X7 2.50 70	
10											5X7 1.15 120	
22											4X7 2.00 85	
33											5X7 0.70 165	
47											6.3X7 0.35 260	
68											5X7 0.70 165	
100											6.3X7 0.35 260	
150											5X7 0.70 165	
220											6.3X7 0.35 260	
330											8X7 0.17 450	
390											8X9 0.15 500	

Rated Ripple Current (mArms/105°C, 100kHz)
 Impedance (Ω max./20°C, 100kHz)
 Case Size øD×L(mm)

RATED RIPPLE CURRENT MULTIPLIERS

Frequency Multipliers

Cap.(µF)	120	1k	10k	50k	100k
1~150	0.40	0.75	0.90	0.95	1.00
220~390	0.50	0.85	0.94	0.97	1.00

DIMENSIONS OF HXB Series

Unit(mm)

Marking : DARK BROWN SLEEVE, SILVER INK

ø D	4	5	6.3	8
ø d	0.45			
F	1.5	2.0	2.5	3.5
ø D'	ø D + 0.5 max.			
L'	L + 1.0 max.			

* ø 8 x 9 L, ø d = 0.60

HXE Series

• 105°C 2,000Hrs assured.

- Non-solvent proof.
- Ultra Low Impedance.
- Height 7mm~9mm.
- For LED TV PSU, DVD Driver.
- RoHS compliant.
- Halogen-free capacitors are also available.

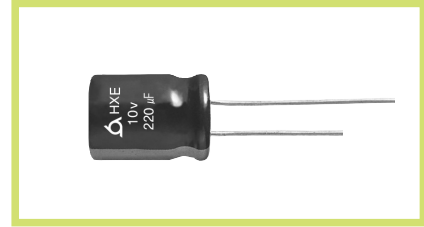
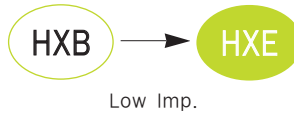

SPECIFICATIONS

Item	Characteristics												
Rated Voltage Range	6.3 ~ 35 V _{DC}												
Operating Temperature Range	-40 ~ +105°C												
Capacitance Tolerance	±20%(M) (at 20°C, 120Hz)												
Leakage Current	I=0.01CV(µA) or 3µA, whichever is greater. Where, I:Max. Leakage current(µA), C:Nominal capacitance(µF), V:Rated voltage(V _{DC}) (at 20°C, 2 minutes)												
Dissipation Factor(Tanδ)	<table border="1"> <tr> <td>Rated voltage(V_{DC})</td> <td>6.3</td> <td>10</td> <td>16</td> <td>25</td> <td>35</td> </tr> <tr> <td>Tanδ(Max.)</td> <td>0.22</td> <td>0.19</td> <td>0.16</td> <td>0.14</td> <td>0.12</td> </tr> </table> (at 20°C, 120Hz)	Rated voltage(V _{DC})	6.3	10	16	25	35	Tanδ(Max.)	0.22	0.19	0.16	0.14	0.12
Rated voltage(V _{DC})	6.3	10	16	25	35								
Tanδ(Max.)	0.22	0.19	0.16	0.14	0.12								
Temperature Characteristics (Max. Impedance ratio)	<table border="1"> <tr> <td>Rated voltage(V_{DC})</td> <td>6.3</td> <td>10</td> <td>16~35</td> </tr> <tr> <td>Z(-25°C)/Z(20°C)</td> <td>2</td> <td>2</td> <td>2</td> </tr> <tr> <td>Z(-40°C)/Z(20°C)</td> <td>6</td> <td>4</td> <td>3</td> </tr> </table> (at 120Hz)	Rated voltage(V _{DC})	6.3	10	16~35	Z(-25°C)/Z(20°C)	2	2	2	Z(-40°C)/Z(20°C)	6	4	3
Rated voltage(V _{DC})	6.3	10	16~35										
Z(-25°C)/Z(20°C)	2	2	2										
Z(-40°C)/Z(20°C)	6	4	3										
Load Life	The following specifications shall be satisfied when the capacitors are restored to 20°C after the rated voltage is applied for 2,000 hours at 105°C. Capacitance change ≤ ±25% of the initial value Tan δ ≤ 200% of the initial specified value Leakage current ≤ The initial specified value												
Shelf Life	The following specifications shall be satisfied when the capacitors are restored to 20°C after exposing them for 1,000 hours at 105°C without voltage applied. The rated voltage shall be applied to the capacitors for a minimum of 30 minutes, at least 24 hours and not more than 48 hours before the measurements. Capacitance change ≤ ±25% of the initial value Tan δ ≤ 200% of the initial specified value Leakage current ≤ The initial specified value												
Others	Satisfied characteristics KS C IEC 60384-4												

RATINGS OF HXE Series

Unit(mm)

Marking : DARK BROWN SLEEVE,
SILVER INK

øD	4	5	6.3	8
ød	0.45			
F	1.5	2.0	2.5	3.5
øD'	øD + 0.5 max.			
L'	L + 1.0 max.			

※ ø8 x 9L, ød=0.60

RATINGS OF HXE Series

WV (V)	Cap. (μF)	∅ D×L(mm)	IMP. (Ω max. / 100kHz)		Rated Ripple Current (mA _{rms} /105°C, 100kHz)
			20°C	-10°C	
6.3	33	4×7	0.56	1.70	230
	47	5×7	0.26	0.86	350
	100	6.3×7	0.15	0.50	480
	330	8×7	0.10	0.35	800
	390	8×9	0.08	0.30	850
10	33	4×7	0.56	1.70	230
	47	5×7	0.26	0.86	350
	150	6.3×7	0.15	0.50	480
	220	8×7	0.10	0.35	800
	330	8×9	0.08	0.30	850
16	22	4×7	0.56	1.70	230
	33	5×7	0.26	0.86	350
	47	5×7	0.26	0.86	350
	100	6.3×7	0.15	0.50	480
	150	8×7	0.10	0.35	800
	220	8×9	0.08	0.30	850
25	10	4×7	0.56	1.70	230
	33	5×7	0.26	0.86	350
	47	6.3×7	0.15	0.50	480
	68	6.3×7	0.15	0.50	480
	100	8×7	0.10	0.35	800
	150	8×9	0.08	0.30	850
35	4.7	4×7	0.64	2.10	230
	10	5×7	0.33	1.10	350
	22	5×7	0.33	1.10	350
	33	6.3×7	0.15	0.50	480
	68	8×7	0.10	0.35	800
	100	8×9	0.08	0.30	850

RATED RIPPLE CURRENT MULTIPLIERS

Frequency Multipliers

Cap.(μF) \ Freq.(Hz)	120	1k	10k	50k	100k
4.7 ~ 150	0.40	0.75	0.90	0.95	1.00
220 ~ 390	0.50	0.85	0.94	0.97	1.00

HXL Series

• 105°C 2,000~3,000Hrs assured.

- Non-solvent proof.
- Low Impedance, Long Life.
- Height 7mm~9mm.
- For LED TV PSU, DVD Driver.
- RoHS compliant.
- Halogen-free capacitors are also available.

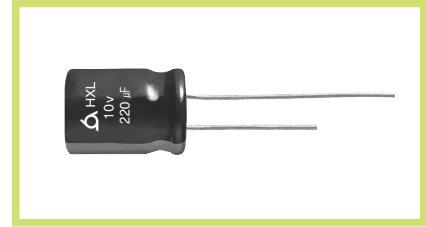

SPECIFICATIONS

Item	Characteristics															
Rated Voltage Range	6.3 ~ 50 V _{DC}															
Operating Temperature Range	-40 ~ +105°C															
Capacitance Tolerance	±20%(M) (at 20°C, 120Hz)															
Leakage Current	I=0.01CV(µA) or 3µA, whichever is greater. Where, I:Max. Leakage current(µA), C:Nominal capacitance(µF), V:Rated voltage(V _{DC}) (at 20°C, 2 minutes)															
Dissipation Factor(Tan δ)	<table border="1"> <tr> <td>Rated voltage(V_{DC})</td> <td>6.3</td> <td>10</td> <td>16</td> <td>25</td> <td>35</td> <td>50</td> </tr> <tr> <td>Tan δ(Max.)</td> <td>0.22</td> <td>0.19</td> <td>0.16</td> <td>0.14</td> <td>0.12</td> <td>0.10</td> </tr> </table> (at 20°C, 120Hz)	Rated voltage(V _{DC})	6.3	10	16	25	35	50	Tan δ(Max.)	0.22	0.19	0.16	0.14	0.12	0.10	
Rated voltage(V _{DC})	6.3	10	16	25	35	50										
Tan δ(Max.)	0.22	0.19	0.16	0.14	0.12	0.10										
Temperature Characteristics (Max. Impedance ratio)	<table border="1"> <tr> <td>Rated voltage(V_{DC})</td> <td>6.3</td> <td>10</td> <td>16</td> <td>25~50</td> </tr> <tr> <td>Z(-25°C)/Z(20°C)</td> <td>2</td> <td>2</td> <td>2</td> <td>2</td> </tr> <tr> <td>Z(-40°C)/Z(20°C)</td> <td>6</td> <td>4</td> <td>3</td> <td>3</td> </tr> </table> (at 120Hz)	Rated voltage(V _{DC})	6.3	10	16	25~50	Z(-25°C)/Z(20°C)	2	2	2	2	Z(-40°C)/Z(20°C)	6	4	3	3
Rated voltage(V _{DC})	6.3	10	16	25~50												
Z(-25°C)/Z(20°C)	2	2	2	2												
Z(-40°C)/Z(20°C)	6	4	3	3												
Load Life	The following specifications shall be satisfied when the capacitors are restored to 20°C after the rated voltage is applied for 3,000 hours at 105°C. (where 2,000 hours for ø4) Capacitance change ≤ ±25% of the initial value Tan δ ≤ 200% of the initial specified value Leakage current ≤ The initial specified value															
Shelf Life	The following specifications shall be satisfied when the capacitors are restored to 20°C after exposing them for 1,000 hours at 105°C without voltage applied. The rated voltage shall be applied to the capacitors for a minimum of 30 minutes, at least 24 hours and not more than 48 hours before the measurements. Capacitance change ≤ ±25% of the initial value Tan δ ≤ 200% of the initial specified value Leakage current ≤ The initial specified value															
Others	Satisfied characteristics KS C IEC 60384-4															

RATINGS OF HXL Series

V _{DC} / µF	6.3			10			16			25			35			50		
1															4X7	3.00	53	
2.2															4X7	2.50	70	
4.7															5X7	1.15	120	
10															4X7	2.00	85	
22															5X7	0.70	165	
33	4X7	1.50	130	4X7	1.50	130	5X7	0.70	165	5X7	0.70	165	6.3X7	0.35	260	8X7	0.17	450
47	5X7	0.70	165	5X7	0.70	165	5X7	0.70	165	6.3X7	0.35	260	8X7	0.17	450	8X7	0.17	450
68	6.3X7	0.35	260	6.3X7	0.35	260	6.3X7	0.35	260	6.3X7	0.35	260	8X7	0.17	450	8X9	0.15	500
100	6.3X7	0.35	260	6.3X7	0.35	260	6.3X7	0.35	260	8X7	0.17	450	8X9	0.15	500			
150	6.3X7	0.35	260	6.3X7	0.35	260	8X7	0.17	450	8X9	0.15	500						
220	8X7	0.17	450	8X7	0.17	450	8X9	0.15	500									
330	8X7	0.17	450	8X9	0.15	500												
390	8X9	0.15	500															

↑ Rated Ripple Current (mA rms/105°C, 100kHz)
 ↑ Impedance (Ω max./20°C, 100kHz)
 ↑ Case Size øD x L (mm)

RATED RIPPLE CURRENT MULTIPLIERS

Frequency Multipliers

Cap. (µF) \ Freq. (Hz)	120	1k	10k	50k	100k
1 ~ 150	0.40	0.75	0.90	0.95	1.00
220 ~ 390	0.50	0.85	0.94	0.97	1.00

DIMENSIONS OF HXL Series

Unit(mm)

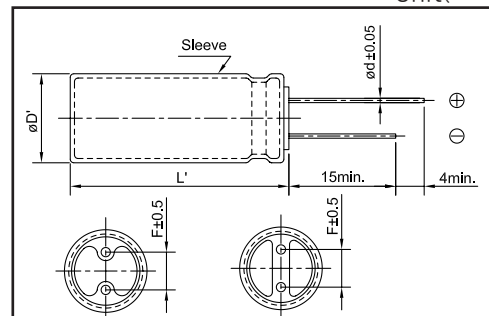

Marking : DARK BROWN SLEEVE, SILVER INK

øD	4	5	6.3	8
ød	0.45			
F	1.5	2.0	2.5	3.5
øD'	øD+0.5max			
L'	L+1.0max			

※ ø8 x 9L, ød=0.60

HML Series

• 105°C 3,000Hrs~5,000Hrs assured.

- Non-solvent proof.
- Long Life.
- Height 7mm~9mm.
- For LED TV PSU, DVD Driver.
- RoHS compliant.
- Halogen-free capacitors are also available.

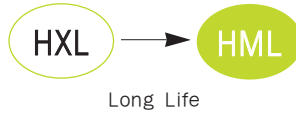

SPECIFICATIONS

Item	Characteristics															
Rated Voltage Range	6.3 ~ 50 V _{DC}															
Operating Temperature Range	-40 ~ +105°C															
Capacitance Tolerance	±20%(M) (at 20°C, 120Hz)															
Leakage Current	I = 0.01CV(μA) or 3μA, whichever is greater. Where, I:Max. Leakage current(μA), C:Nominal capacitance(μF), V:Rated voltage(V _{DC}) (at 20°C, 2 minutes)															
Dissipation Factor(Tanδ)	<table border="1"> <tr> <td>Rated voltage(V_{DC})</td> <td>6.3</td> <td>10</td> <td>16</td> <td>25</td> <td>35</td> <td>50</td> </tr> <tr> <td>Tanδ(Max.)</td> <td>0.22</td> <td>0.19</td> <td>0.16</td> <td>0.14</td> <td>0.12</td> <td>0.10</td> </tr> </table> (at 20°C, 120Hz)	Rated voltage(V _{DC})	6.3	10	16	25	35	50	Tanδ(Max.)	0.22	0.19	0.16	0.14	0.12	0.10	
Rated voltage(V _{DC})	6.3	10	16	25	35	50										
Tanδ(Max.)	0.22	0.19	0.16	0.14	0.12	0.10										
Temperature Characteristics (Max. Impedance ratio)	<table border="1"> <tr> <td>Rated voltage(V_{DC})</td> <td>6.3</td> <td>10</td> <td>16</td> <td>25~50</td> </tr> <tr> <td>Z(-25°C)/Z(+20°C)</td> <td>2</td> <td>2</td> <td>2</td> <td>2</td> </tr> <tr> <td>Z(-40°C)/Z(+20°C)</td> <td>6</td> <td>4</td> <td>3</td> <td>3</td> </tr> </table> (at 120Hz)	Rated voltage(V _{DC})	6.3	10	16	25~50	Z(-25°C)/Z(+20°C)	2	2	2	2	Z(-40°C)/Z(+20°C)	6	4	3	3
Rated voltage(V _{DC})	6.3	10	16	25~50												
Z(-25°C)/Z(+20°C)	2	2	2	2												
Z(-40°C)/Z(+20°C)	6	4	3	3												
Load Life	The following specifications shall be satisfied when the capacitors are restored to 20°C after the rated voltage is applied for 5,000 hours at 105°C.(where 3,000 hours for ø4, 4,000 hours for ø5) Capacitance change ≤ ±30% of the initial value Tanδ ≤ 200% of the initial specified value Leakage current ≤ The initial specified value															
Shelf Life	The following specifications shall be satisfied when the capacitors are restored to 20°C after exposing them for 1,000 hours at 105°C without voltage applied. The rated voltage shall be applied to the capacitors for a minimum of 30 minutes, at least 24 hours and not more than 48 hours before the measurements. Capacitance change ≤ ±30% of the initial value Tanδ ≤ 200% of the initial specified value Leakage current ≤ The initial specified value															
Others	Satisfied characteristics KS C IEC 60384-4															

RATINGS OF HML Series

V _{DC} / μF	6.3	10	16	25	35	50
1						4X7 53 5X7 80
2.2						4X7 70 5X7 120
4.7						4X7 85 5X7 165
10						6.3X7 260
22					5X7 165	6.3X7 260
33	4X7 130 5X7 165	4X7 130 5X7 165	5X7 165	5X7 165	6.3X7 260	8X7 450
47	5X7 165	5X7 165	5X7 165	6.3X7 260	8X7 450	8X7 450
68	6.3X7 260	6.3X7 260	6.3X7 260	6.3X7 260	8X7 450	8X9 500
100	6.3X7 260	6.3X7 260	6.3X7 260	8X7 450	8X9 500	
150	6.3X7 260	6.3X7 260	8X7 450	8X9 500		
220	8X7 450	8X7 450	8X9 500			
330	8X7 450	8X9 500				
390	8X9 500					

↑ Rated Ripple Current (mA rms/105°C, 100kHz)
↑ Case Size øD × L (mm)

RATED RIPPLE CURRENT MULTIPLIERS

Cap.(μF) \ Freq.(Hz)	120	1k	10k	50k	100k
1 ~ 150	0.40	0.75	0.90	0.95	1.00
220 ~ 390	0.50	0.85	0.94	0.97	1.00

DIMENSIONS OF HML Series

Unit(mm)

Marking : DARK BROWN SLEEVE, SILVER INK

øD	4	5	6.3	8
ød	0.45			
F	1.5	2.0	2.5	3.5
øD'	øD+0.5max			
L'	L+1.0max			

* ø8 x 9L, ød=0.60

MHA Series

• 85°C 2,000Hrs assured.

- Non-solvent proof.
- For Digital Household Appliance.
- RoHS compliant.
- Halogen-free capacitors are also available.



SPECIFICATIONS

Item	Characteristics																																										
Rated Voltage Range	6.3 ~ 100 V _{DC}	160 ~ 500 V _{DC}																																									
Operating Temperature Range	-40 ~ +85°C	-25 ~ +85°C																																									
Capacitance Tolerance	±20% (M) (at 20°C, 120Hz)																																										
Leakage Current	After 1 minute: I = 0.03CV(μA) or 4μA, whichever is greater.	<table border="1"> <tr> <th colspan="2">After 1 minute</th> <th colspan="2">After 5 minutes</th> </tr> <tr> <td>CV ≤ 1,000</td> <td>CV > 1,000</td> <td>CV ≤ 1,000</td> <td>CV > 1,000</td> </tr> <tr> <td>0.1CV + 40</td> <td>0.04CV + 100</td> <td>0.03CV + 15</td> <td>0.02CV + 25</td> </tr> </table>	After 1 minute		After 5 minutes		CV ≤ 1,000	CV > 1,000	CV ≤ 1,000	CV > 1,000	0.1CV + 40	0.04CV + 100	0.03CV + 15	0.02CV + 25																													
	After 1 minute		After 5 minutes																																								
CV ≤ 1,000	CV > 1,000	CV ≤ 1,000	CV > 1,000																																								
0.1CV + 40	0.04CV + 100	0.03CV + 15	0.02CV + 25																																								
	After 2 minutes: I = 0.01CV(μA) or 3μA, whichever is greater.																																										
	Where, I: Max. Leakage current(μA), C: Nominal capacitance(μF), V: Rated voltage(V _{DC}) (at 20°C)																																										
Dissipation Factor (Tanδ)	<table border="1"> <tr> <th>Rated Voltage(V_{DC})</th> <td>6.3</td> <td>10</td> <td>16</td> <td>25</td> <td>35</td> <td>50</td> <td>63</td> <td>100</td> <td>160~250</td> <td>350~500</td> </tr> <tr> <th>Tanδ(Max.)</th> <td>0.34</td> <td>0.24</td> <td>0.20</td> <td>0.16</td> <td>0.14</td> <td>0.12</td> <td>0.10</td> <td>0.09</td> <td>0.20</td> <td>0.24</td> </tr> </table>										Rated Voltage(V _{DC})	6.3	10	16	25	35	50	63	100	160~250	350~500	Tanδ(Max.)	0.34	0.24	0.20	0.16	0.14	0.12	0.10	0.09	0.20	0.24											
	Rated Voltage(V _{DC})	6.3	10	16	25	35	50	63	100	160~250	350~500																																
Tanδ(Max.)	0.34	0.24	0.20	0.16	0.14	0.12	0.10	0.09	0.20	0.24																																	
	When the capacitance exceeds 1,000μF, 0.02 shall be added every 1,000μF increase. (at 20°C, 120Hz)																																										
Temperature Characteristics (Max. Impedance ratio)	<table border="1"> <tr> <th>Rated Voltage(V_{DC})</th> <td>6.3</td> <td>10</td> <td>16</td> <td>25</td> <td>35</td> <td>50</td> <td>63~100</td> <td>160</td> <td>200~250</td> <td>350~500</td> </tr> <tr> <th>Z(-25°C)/Z(20°C)</th> <td>5</td> <td>4</td> <td>3</td> <td>2</td> <td>2</td> <td>2</td> <td>3</td> <td>4</td> <td>8</td> <td>16</td> </tr> <tr> <th>Z(-40°C)/Z(20°C)</th> <td>12</td> <td>10</td> <td>8</td> <td>5</td> <td>4</td> <td>3</td> <td>4</td> <td>-</td> <td>-</td> <td>-</td> </tr> </table>										Rated Voltage(V _{DC})	6.3	10	16	25	35	50	63~100	160	200~250	350~500	Z(-25°C)/Z(20°C)	5	4	3	2	2	2	3	4	8	16	Z(-40°C)/Z(20°C)	12	10	8	5	4	3	4	-	-	-
	Rated Voltage(V _{DC})	6.3	10	16	25	35	50	63~100	160	200~250	350~500																																
	Z(-25°C)/Z(20°C)	5	4	3	2	2	2	3	4	8	16																																
Z(-40°C)/Z(20°C)	12	10	8	5	4	3	4	-	-	-																																	
	(at 120Hz)																																										
Load Life	The following specifications shall be satisfied when the capacitors are restored to 20°C after the rated voltage is applied for 2,000 hours at 85°C.																																										
	Capacitance change ≤ ±20% of the initial value Tanδ ≤ 200% of the initial specified value Leakage current ≤ The initial specified value																																										
Shelf Life	The following specifications shall be satisfied when the capacitors are restored to 20°C after exposing them for 1,000 hours at 85°C without voltage applied. The rated voltage shall be applied to the capacitors for a minimum of 30 minutes, at least 24 hours and not more than 48 hours before the measurements.																																										
	Capacitance change ≤ ±20% of the initial value Tanδ ≤ 200% of the initial specified value Leakage current ≤ The initial specified value (where, 200% for ≥ WV 160 V _{DC})																																										
Others	Satisfied characteristics KS C IEC 60384-4																																										

DIMENSIONS OF MHA Series

Unit(mm)

Labels: Safety vent(φ6.3), Sleeve, L', 15min., 4min., φD, φd, F, φD', φ10, φ12.5, F±0.5, F±0.5.

Marking : BLACK SLEEVE, WHITE INK

φD	5	6.3	8	10	12.5	16	18	22
φd	0.5	0.5	0.6	0.6	0.6	0.8	0.8	1.0
F	2.0	2.5	3.5	5.0	5.0	7.5	7.5	10.0
φD'	φD + 0.5 max.							
L'	L + 1.5 max.				L + 2.0 max.			

※ φ8 x 9L, φD' ≤ D + 0.5 and L' ≤ L + 1.0

RATINGS OF MHA Series

μF \ V _{DC}	6.3	10	16	25	35	50	63	100	160	200	250	350	400	450	500
1						5×11 22	5×11 24	5×11 24	5×11 20 6.3×11 23	5×11 20 6.3×11 23	5×11 24 6.3×11 27	6.3×11 28	6.3×11 29	6.3×11 24	
2.2						5×11 34	5×11 35	5×11 37	5×11 29 6.3×11 33	5×11 34 6.3×11 39	6.3×11 41	6.3×11 43	6.3×11 44	6.3×11 34 8×11.5 40	8×11.5 34
3.3						5×11 41	5×11 43	5×11 44	6.3×11 46	6.3×11 47	6.3×11 48	6.3×11 48 8×11.5 56	6.3×11 51 8×11.5 59	8×11 46 10×12.5 54	8×11 43 10×12.5 50
4.7					5×11 35	5×11 48	5×11 53	5×11 55	6.3×11 56	6.3×11 57	6.3×11 58 8×11.5 66	8×11.5 68	8×11 70 10×12.5 73	10×12.5 65	10×16 68
6.8					5×11 46	5×11 59	5×11 63	5×11 64	6.3×11 67 8×11.5 78	6.3×11 69 8×11.5 80	8×11.5 82	8×11 79 10×12.5 92	10×12.5 95	10×16 83	10×16 78
10			5×11 39	5×11 49	5×11 53	5×11 71	5×11 76	5×11 76	6.3×11 78 8×11.5 82	8×11.5 96	8×11 97 10×12.5 113	10×12.5 106	10×16 123	12.5×16 111	12.5×16 101
22		5×11 52	5×11 68	5×11 73	5×11 80	5×11 106	5×11 113	6.3×11 130	10×12.5 136	10×12.5 152	10×16 182	12.5×16 205	10×25 229	16×20 216	16×20 140
33	5×11 41	5×11 70	5×11 80	5×11 83	5×11 100	5×11 129 8×9 98	6.3×11 159	8×11.5 187	10×16 224	10×16 226	12.5×16 262	12.5×20 275	12.5×20 294	16×20 297	16×25 204
47	5×11 59	5×11 88	5×11 120	5×11 126	5×11 138 8×9 98	6.3×11 177 8×9 110	6.3×11 190	8×11 223 8×15 246	10×16 277	12.5×16 315	12.5×20 340	16×20 395	16×20 407	16×25 368	18×25 233
68	5×11 90	5×11 110	5×11 130	5×11 151	5×11 168 6.3×11 191	6.3×11 213	8×11.5 269	10×12.5 311	12.5×16 377	12.5×20 441	16×20 490	16×25 500	16×25 522	16×31.5 544	18×31.5 269
100	5×11 135	5×11 150	5×11 170	5×11 184 8×9 115	6.3×11 231	8×11.5 306	8×11.5 321	10×16 416	12.5×20 496	16×20 543	16×20 550	16×31.5 674	18×31.5 698	18×35.5 620	
220	5×11 211	5×11 229 8×9 150	5×11 256 6.3×11 290	6.3×11 318	8×11.5 405	10×12.5 506	10×16 615	12.5×20 742	16×25 906	16×31.5 1,029	18×31.5 1,040	22×35 1,074	22×45 1,150		
330	5×11 262 6.3×11 297	6.3×11 322	6.3×11 360	8×11.5 453	8×11 494 8×15 547	10×16 706	10×20 823	12.5×25 987	18×31.5 1,304	18×31.5 1,281	22×35 1,333				
470	6.3×11 355 8×9 241	6.3×11 384	8×11.5 499	8×11 540 8×15 597	10×12.5 682	10×20 918	12.5×20 1,039	16×20 1,299	22×30 1,421	22×35 1,459					
680	8×11.5 503	8×11.5 546	8×11 584 8×15 655	10×16 826	10×16 909	12.5×16 1,190	12.5×25 1,512	16×31.5 1,587	22×40 1,680						
1,000	8×11.5 610	8×11 679 8×15 751	10×12.5 840	10×16 1,007	10×20 1,163	12.5×25 1,715	16×20 1,724	18×31.5 1,932							
2,200	10×16 1,059	10×16 1,129	10×20 1,340	12.5×20 1,651	12.5×30 1,933	16×31.5 2,320	18×31.5 2,654								
3,300	10×20 1,350	10×25 1,657	10×30 1,804	12.5×30 2,159	16×25 2,314	18×31.5 3,118									
4,700	12.5×20 1,822	12.5×20 1,929	16×20 2,200	16×25 2,464	16×35.5 3,061										
6,800	12.5×20 2,235	12.5×30 2,545	16×25 2,690	16×31.5 2,992											
10,000	16×20 2,571	16×25 2,742	16×31.5 3,420												
15,000	16×31.5 3,453	18×31.5 3,707													

Case Size \varnothing D×L(mm)
 Rated Ripple Current(mArms/85°C, 120Hz)

RATED RIPPLE CURRENT MULTIPLIERS

Frequency Multipliers

Cap. (μF) \ Freq. (Hz)	60	120	300	1k	10k~
1~6.8	0.65	1.00	1.35	1.75	2.30
10~68	0.75	1.00	1.25	1.50	1.75
100~1,000	0.80	1.00	1.15	1.30	1.40
2,200~15,000	0.85	1.00	1.03	1.05	1.08

NHA Series

• 105°C 1,000~2,000Hrs assured.

Solvent-proof

WV ≤ 100V_{DC}

- For Digital Household Appliance.
- RoHS compliant.
- Halogen-free capacitors are also available.

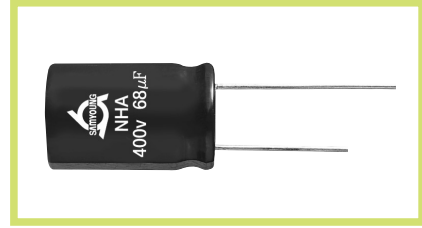

SPECIFICATIONS

Item	Characteristics																																										
Rated Voltage Range	6.3 ~ 100 V _{DC}	160 ~ 400 V _{DC}	450 ~ 500 V _{DC}																																								
Operating Temperature Range	-55 ~ +105°C	-40 ~ +105°C	-25 ~ +105°C																																								
Capacitance Tolerance	±20% (M) (at 20°C, 120Hz)																																										
Leakage Current	After 1 minute: I=0.03CV(μA) or 4μA, whichever is greater.	After 1 minute																																									
	After 2 minutes: I=0.01CV(μA) or 3μA, whichever is greater.	CV ≤ 1,000	CV > 1,000																																								
		0.1CV+40	0.04CV+100																																								
		After 5 minutes																																									
		CV ≤ 1,000	CV > 1,000																																								
		0.03CV+15	0.02CV+25																																								
	Where, I:Max. Leakage current(μA), C:Nominal capacitance(μF), V:Rated voltage(V _{DC}) (at 20°C)																																										
Dissipation Factor (Tanδ)	<table border="1"> <tr> <td>Rated Voltage(V_{DC})</td> <td>6.3</td> <td>10</td> <td>16</td> <td>25</td> <td>35</td> <td>50</td> <td>63</td> <td>100</td> <td>160~250</td> <td>350~500</td> </tr> <tr> <td>Tanδ(Max.)</td> <td>0.34</td> <td>0.24</td> <td>0.20</td> <td>0.16</td> <td>0.14</td> <td>0.12</td> <td>0.10</td> <td>0.09</td> <td>0.20</td> <td>0.24</td> </tr> </table>										Rated Voltage(V _{DC})	6.3	10	16	25	35	50	63	100	160~250	350~500	Tanδ(Max.)	0.34	0.24	0.20	0.16	0.14	0.12	0.10	0.09	0.20	0.24											
	Rated Voltage(V _{DC})	6.3	10	16	25	35	50	63	100	160~250	350~500																																
Tanδ(Max.)	0.34	0.24	0.20	0.16	0.14	0.12	0.10	0.09	0.20	0.24																																	
	When the capacitance exceeds 1,000μF, 0.02 shall be added every 1,000μF increase. (at 20°C, 120Hz)																																										
Temperature Characteristics (Max. Impedance ratio)	<table border="1"> <tr> <td>Rated Voltage(V_{DC})</td> <td>6.3</td> <td>10</td> <td>16</td> <td>25</td> <td>35</td> <td>50</td> <td>63~100</td> <td>160</td> <td>200~400</td> <td>450~500</td> </tr> <tr> <td>Z(-25°C)/Z(20°C)</td> <td>5</td> <td>4</td> <td>3</td> <td>2</td> <td>2</td> <td>2</td> <td>3</td> <td>3</td> <td>6</td> <td>6</td> </tr> <tr> <td>Z(-40°C)/Z(20°C)</td> <td>12</td> <td>10</td> <td>8</td> <td>5</td> <td>4</td> <td>3</td> <td>4</td> <td>5</td> <td>6</td> <td>-</td> </tr> </table>										Rated Voltage(V _{DC})	6.3	10	16	25	35	50	63~100	160	200~400	450~500	Z(-25°C)/Z(20°C)	5	4	3	2	2	2	3	3	6	6	Z(-40°C)/Z(20°C)	12	10	8	5	4	3	4	5	6	-
	Rated Voltage(V _{DC})	6.3	10	16	25	35	50	63~100	160	200~400	450~500																																
	Z(-25°C)/Z(20°C)	5	4	3	2	2	2	3	3	6	6																																
Z(-40°C)/Z(20°C)	12	10	8	5	4	3	4	5	6	-																																	
	(at 120Hz)																																										
Load Life	<p>The following specifications shall be satisfied when the capacitors are restored to 20°C after the rated voltage is applied for 2,000 hours at 105°C.(where, 1,000 hours ≤ ∅ 8)</p> <p>Capacitance change ≤ ±20% of the initial value</p> <p>Tanδ ≤ 200% of the initial specified value</p> <p>Leakage current ≤ The initial specified value</p>																																										
Shelf Life	<p>The following specifications shall be satisfied when the capacitors are restored to 20°C after exposing them for 1,000 hours at 105°C without voltage applied.(where, 500 hours ≤ ∅ 8)</p> <p>The rated voltage shall be applied to the capacitors for a minimum of 30 minutes, at least 24 hours and not more than 48 hours before the measurements.</p> <p>Capacitance change ≤ ±20% of the initial value</p> <p>Tanδ ≤ 200% of the initial specified value</p> <p>Leakage current ≤ The initial specified value (where, 200% for ≥ WV 160 V_{DC})</p>																																										
Others	Satisfied characteristics KS C IEC 60384-4																																										

DIMENSIONS OF NHA Series

Unit(mm)

Marking : BROWN SLEEVE, WHITE INK

∅D	5	6.3	8	10	12.5	16	18	22
∅d	0.5	0.5	0.6	0.6	0.6	0.8	0.8	1.0
F	2.0	2.5	3.5	5.0	5.0	7.5	7.5	10.0
∅D'	∅D+0.5 max.							
L'	L+1.5 max.				L+2.0 max.			

RATINGS OF NHA Series

$\mu F \backslash V_{DC}$	6.3	10	16	25	35	50	63	100	160	200	250	350	400	450	500
1						5×11 13	5×11 15	5×11 16	5×11 12 6.3×11 14	5×11 13 6.3×11 15	5×11 15 6.3×11 17	6.3×11 18	6.3×11 19	6.3×11 14	
2.2						5×11 18	5×11 19	5×11 21	5×11 17 6.3×11 20	6.3×11 24	6.3×11 27	6.3×11 28 8×11.5 29	6.3×11 28 8×11.5 30	6.3×11 22 8×11.5 25	8×11.5 22
3.3						5×11 30	5×11 33	5×11 34	6.3×11 35	6.3×11 36	6.3×11 37	6.3×11 38 8×11.5 38	8×11 39 10×12.5 41	8×11 30 10×12.5 35	10×12.5 29
4.7				5×11 25	5×11 27	5×11 37	5×11 39	5×11 40	6.3×11 41	6.3×11 43	6.3×11 44 8×11.5 45	8×11.5 45	8×11.5 46 10×12.5 48	10×12.5 38	10×12.5 36
6.8				5×11 31	5×11 33	5×11 44	5×11 48	5×11 49	8×11.5 52	8×11.5 54	8×11.5 56	10×12.5 58	10×12.5 59	10×16 54	10×16 50
10			5×11 35	5×11 37	5×11 40	5×11 54	5×11 59	5×11 59	8×11.5 60	8×11.5 62	10×12.5 67	10×16 73	10×16 79	10×16 70	12.5×16 66
22		5×11 48	5×11 53	5×11 56	5×11 67	5×11 79	5×11 87	6.3×11 100	10×12.5 101	10×12.5 102	10×16 117	12.5×16 138	10×25 157	12.5×20 125	16×20 123
33	5×11 52	5×11 56	5×11 60	5×11 75	5×11 80	5×11 97	6.3×11 122	8×11.5 144	10×16 143	10×16 145	12.5×16 169	12.5×25 189	16×20 210	12.5×30 189	16×25 165
47	5×11 61	5×11 66	5×11 77	5×11 80	5×11 101	6.3×11 133	6.3×11 146	8×11.5 171 8×15 189	10×20 202	12.5×16 206	12.5×20 218	16×20 246	16×25 280	16×25 222	18×25 188
68	5×11 69	5×11 83	5×11 92	5×11 113	5×11 122 6.3×11 138	6.3×11 156	8×11.5 207	10×12.5 239	12.5×16 252	12.5×20 265	16×20 300	16×25 322	16×31.5 376	18×31.5 338	
100	5×11 90	5×11 100	5×11 125	5×11 141 6.3×11 159	6.3×11 168	8×11.5 229	8×11.5 216 10×12.5 251	10×16 321	12.5×25 360	16×20 366	16×25 405	16×35.5 447	18×35.5 453	22×30 414	
220	5×11 153	5×11 170	6.3×11 213	6.3×11 238	8×11.5 294	10×12.5 395	10×16 474	12.5×20 572	16×25 656	16×31.5 684	18×35.5 719	22×45 780			
330	6.3×11 216	6.3×11 239	6.3×11 265	8×11.5 340	8×11 360 8×15 398	10×16 529	10×20 633	16×20 810	18×31.5 848	18×35.5 866	22×35 880				
470	6.3×11 258	6.3×11 286	8×11.5 366	8×11.5 406 8×15 447	10×16 547	10×20 690	12.5×20 886	16×25 1,072	22×35 1,130	22×40 1,156					
680	8×11.5 365	8×11.5 405	8×11.5 413 8×15 455	10×16 620	12.5×16 777	12.5×20 973	12.5×25 1,160	16×31.5 1,364	22×45 1,463						
1,000	8×11.5 443	8×15 542	10×16 680	10×16 756	12.5×16 940	12.5×25 1,287	16×25 1,565	18×35.5 1,987							
2,200	10×16 772	10×20 886	12.5×16 1,019	12.5×20 1,188	16×20 1,394	16×31.5 1,724	18×35.5 1,938								
3,300	10×20 1,032	12.5×20 1,205	12.5×20 1,275	16×20 1,535	16×31.5 1,808	18×31.5 2,190									
4,700	12.5×20 1,280	12.5×25 1,492	16×20 1,610	16×25 1,865	18×31.5 2,262										
6,800	12.5×25 1,554	16×20 1,699	16×25 1,929	18×31.5 2,374	18×40 2,642										
10,000	16×25 1,897	16×31.5 2,082	18×31.5 2,365	18×35.5 2,649											
15,000	16×31.5 2,297														

Case Size $\varnothing D \times L$ (mm)
 Rated Ripple Current(mArms/105°C, 120Hz)

RATED RIPPLE CURRENT MULTIPLIERS

Frequency Multipliers

Cap.(μF) \ Freq.(Hz)	60	120	300	1k	10k~
1~6.8	0.65	1.00	1.35	1.75	2.30
10~68	0.75	1.00	1.25	1.50	1.75
100~1,000	0.80	1.00	1.15	1.30	1.40
2,200~15,000	0.85	1.00	1.03	1.05	1.08

* SMT Products are available upon request.
 Please check with us about individual characteristics.

GSA-LL Series

- Non-solvent proof.
- Height 7mm.
- Low leakage current.
- For CAR-Audio.

- 85°C 2,000Hrs assured.
- RoHS compliant.
- Halogen-free capacitors are also available.



LL Series

- Non-solvent proof.
- Very low leakage current.
- For CAR-Audio.

- 85°C 2,000Hrs assured.
- RoHS compliant.
- Halogen-free capacitors are also available.

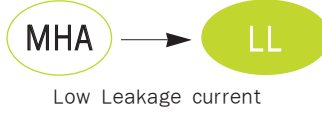

SPECIFICATIONS

Item	Characteristics																										
Rated Voltage Range	6.3 ~ 100 V _{DC}																										
Operating Temperature Range	-40 ~ +85°C																										
Capacitance Tolerance	±20% (M) (at 20°C, 120Hz)																										
Leakage Current(Max.)	GSA-LL Series : I = 0.004CV(μA) or 0.4μA, whichever is greater. LL Series : I = 0.002CV(μA) or 0.2μA, whichever is greater. Where, I:Max. Leakage current(μA), C:Nominal capacitance(μF), V:Rated voltage(V _{DC}) (at 20°C, 2 minutes)																										
Dissipation Factor(Tanδ)	<table border="1"> <tr> <td>Rated Voltage(V_{DC})</td> <td>6.3</td> <td>10</td> <td>16</td> <td>25</td> <td>35</td> <td>50~63</td> <td>100</td> </tr> <tr> <td>Tan δ(Max.)</td> <td>0.24</td> <td>0.20</td> <td>0.16</td> <td>0.14</td> <td>0.12</td> <td>0.10</td> <td>0.07</td> </tr> </table> (at 20°C, 120Hz)	Rated Voltage(V _{DC})	6.3	10	16	25	35	50~63	100	Tan δ(Max.)	0.24	0.20	0.16	0.14	0.12	0.10	0.07										
Rated Voltage(V _{DC})	6.3	10	16	25	35	50~63	100																				
Tan δ(Max.)	0.24	0.20	0.16	0.14	0.12	0.10	0.07																				
Temperature Characteristics (Max. Impedance ratio)	<table border="1"> <tr> <td rowspan="3">Rated Voltage(V_{DC})</td> <td>GSA-LL Series</td> <td colspan="5">LL Series</td> </tr> <tr> <td>—</td> <td>6.3</td> <td>10</td> <td>16</td> <td>25</td> <td>35~100</td> </tr> <tr> <td>Z(-25°C)/Z(+20°C)</td> <td>4</td> <td>4</td> <td>3</td> <td>2</td> <td>2</td> </tr> <tr> <td>Z(-40°C)/Z(+20°C)</td> <td>8</td> <td>8</td> <td>6</td> <td>4</td> <td>3</td> <td>3</td> </tr> </table> (at 120Hz)	Rated Voltage(V _{DC})	GSA-LL Series	LL Series					—	6.3	10	16	25	35~100	Z(-25°C)/Z(+20°C)	4	4	3	2	2	Z(-40°C)/Z(+20°C)	8	8	6	4	3	3
Rated Voltage(V _{DC})	GSA-LL Series		LL Series																								
	—		6.3	10	16	25	35~100																				
	Z(-25°C)/Z(+20°C)	4	4	3	2	2																					
Z(-40°C)/Z(+20°C)	8	8	6	4	3	3																					
Load Life	The following specifications shall be satisfied when the capacitors are restored to 20°C after the rated voltage is applied for 2,000 hours at 85°C. Capacitance change ≤ ±20% of the initial value Tan δ ≤ 200% of the initial specified value Leakage current ≤ The initial specified value																										
Shelf Life	The following specifications shall be satisfied when the capacitors are restored to 20°C after exposing them for 500 hours at 85°C without voltage applied. The rated voltage shall be applied to the capacitors for a minimum of 30 minutes, at least 24 hours and not more than 48 hours before the measurements. Capacitance change ≤ ±20% of the initial value Tan δ ≤ 200% of the initial specified value Leakage current ≤ The initial specified value																										
Others	Satisfied characteristics KS C IEC 60384-4																										

DIMENSIONS OF GSA-LL Series

Unit(mm)

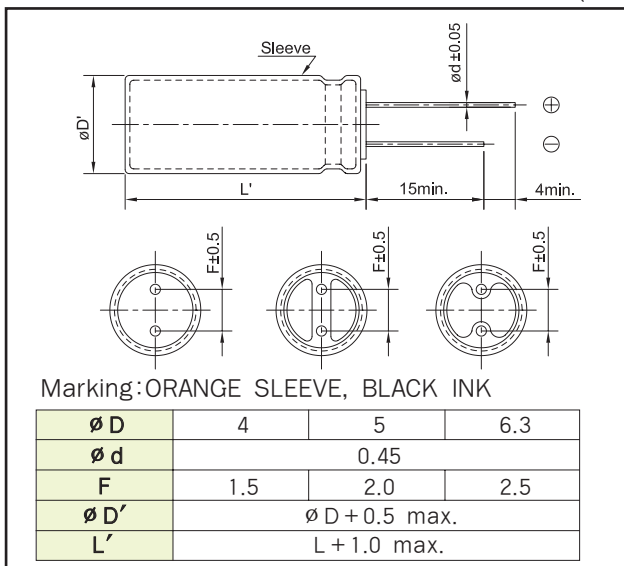

DIMENSIONS OF LL Series

Unit(mm)

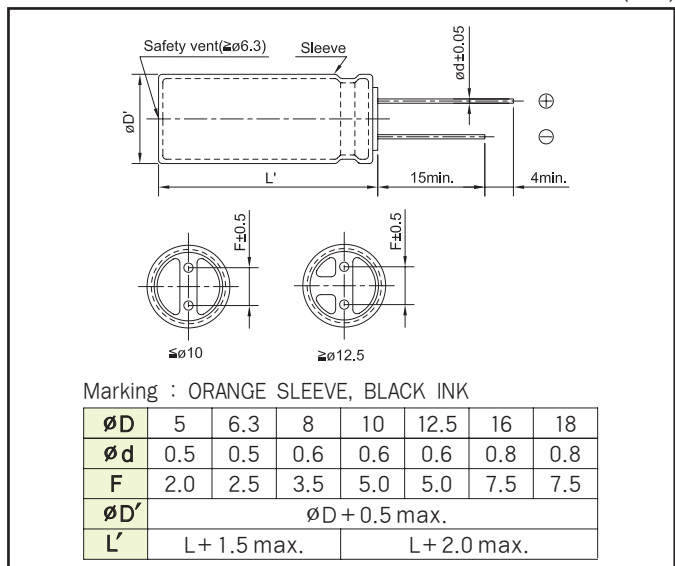

RATINGS OF GSA-LL Series

μF \ V _{DC}	6.3		10		16		25		35		50	
	1					4×7	9.2					4×7
1.5					4×7	11					4×7	14
2.2					4×7	12					4×7	17
3.3					4×7	15	4×7	17	4×7	18	5×7	21
4.7					4×7	20	4×7	21	5×7	22	6.3×7	25
6.8					5×7	23	5×7	25	6.3×7	28	6.3×7	31
10			4×7	25	5×7	27	5×7	30	6.3×7	33	6.3×7	40
15	4×7	28	5×7	30	6.3×7	33	6.3×7	37	6.3×7	39		
22	5×7	33	5×7	37	6.3×7	42	6.3×7	45	6.3×7	49		
33	5×7	41	6.3×7	45	6.3×7	52	6.3×7	55				
47	6.3×7	49	6.3×7	55	6.3×7	62						
68	6.3×7	59	6.3×7	65								
100	6.3×7	73										

↑ Rated Ripple Current (mA_{rms}/85°C, 120Hz)
 ↑ Case Size ∅ D × L (mm)

RATINGS OF LL Series

μF \ V _{DC}	6.3		10		16		25		35		50		63		100	
	1											5×11	16			5×11
2.2											5×11	23			6.3×11	31
3.3											5×11	28			8×11.5	44
4.7							5×11	28	5×11	31	6.3×11	38			8×11.5	52
10					5×11	39	6.3×11	47	6.3×11	51	8×11.5	64	8×11.5	64	10×16	100
22			5×11	51	6.3×11	66	8×11.5	80	8×11.5	87	10×12.5	112	10×16	124	10×20	160
33			6.3×11	72	6.3×11	80	8×11.5	98	10×12.5	125	10×16	151	10×16	151	12.5×20	217
47			6.3×11	86	8×11.5	110	10×12.5	138	10×12.5	149	10×16	181	10×20	196	12.5×25	282
100			8×11.5	143	10×12.5	189	10×16	223	10×20	260	12.5×20	316	12.5×25	344	16×25	455
220	10×12.5	229	10×16	276	10×20	335	12.5×20	397	12.5×25	466	16×25	564	16×31.5	607	18×35.5	775
330	10×16	309	10×20	367	12.5×20	454	12.5×25	528	12.5×25	631	16×31.5	744	16×35.5	761	18×40	964
470	10×20	399	12.5×20	485	12.5×20	542	16×25	697	16×25	753	16×35.5	908	18×35.5	948		
1,000	12.5×25	702	12.5×25	769	16×25	951	18×35.5	1,120	16×25	1,262	18×40	1,404				
2,200	16×25	1,107	16×31.5	1,295	18×35.5	1,529	18×40	1,647								
3,300	16×35.5	1,438	16×35.5	1,554	18×40	1,804										
4,700	18×35.5	1,676	18×40	1,820												

↑ Rated Ripple Current (mA_{rms}/85°C, 120Hz)
 ↑ Case Size ∅ D × L (mm)

GSA-BP Series

• 85°C 2,000Hrs assured.

- Non-solvent proof.
- Height 7mm.
- Bi-polarized.
- For CAR-Audio, VCR.
- RoHS compliant.
- Halogen-free capacitors are also available.

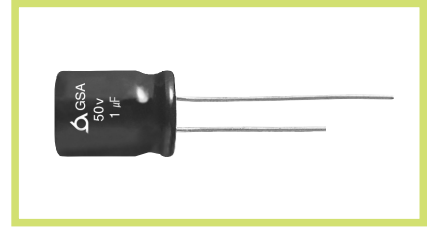
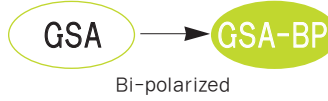

SPECIFICATIONS

Item	Characteristics																		
Rated Voltage Range	6.3 ~ 50 V _{DC}																		
Operating Temperature Range	-40 ~ +85°C																		
Capacitance Tolerance	±20%(M) (at 20°C, 120Hz)																		
Leakage Current (In both directions)	I = 0.06CV(µA) or 10µA, whichever is greater. Where, I:Max. Leakage current(µA), C:Nominal capacitance(µF), V:Rated voltage(V _{DC}) (at 20°C, 1 minute)																		
Dissipation Factor(Tan δ)	<table border="1"> <tr> <td>Rated voltage(V_{DC})</td> <td>6.3</td> <td>10</td> <td>16</td> <td>25</td> <td>35</td> <td>50</td> </tr> <tr> <td>Tan δ(Max.)</td> <td>0.24</td> <td>0.20</td> <td>0.17</td> <td>0.16</td> <td>0.15</td> <td>0.14</td> </tr> </table> (at 20°C, 120Hz)	Rated voltage(V _{DC})	6.3	10	16	25	35	50	Tan δ(Max.)	0.24	0.20	0.17	0.16	0.15	0.14				
Rated voltage(V _{DC})	6.3	10	16	25	35	50													
Tan δ(Max.)	0.24	0.20	0.17	0.16	0.15	0.14													
Temperature Characteristics (Max. Impedance ratio)	<table border="1"> <tr> <td>Rated voltage(V_{DC})</td> <td>6.3</td> <td>10</td> <td>16</td> <td>25</td> <td>35~50</td> </tr> <tr> <td>Z(-25°C)/Z(20°C)</td> <td>4</td> <td>3</td> <td>2</td> <td>2</td> <td>2</td> </tr> <tr> <td>Z(-40°C)/Z(20°C)</td> <td>10</td> <td>8</td> <td>6</td> <td>4</td> <td>3</td> </tr> </table> (at 120Hz)	Rated voltage(V _{DC})	6.3	10	16	25	35~50	Z(-25°C)/Z(20°C)	4	3	2	2	2	Z(-40°C)/Z(20°C)	10	8	6	4	3
Rated voltage(V _{DC})	6.3	10	16	25	35~50														
Z(-25°C)/Z(20°C)	4	3	2	2	2														
Z(-40°C)/Z(20°C)	10	8	6	4	3														
Load Life	<p>The following specifications shall be satisfied when the capacitors are restored to 20°C after the rated is voltage for 2,000 hours at 85°C. During the test, the rated voltage shall be reversed on the capacitor every 250 hours.</p> <p>Capacitance change ≤ ±20% of the initial value Tan δ ≤ 200% of the initial specified value Leakage current ≤ The initial specified value</p>																		
Shelf Life	<p>The following specifications shall be satisfied when the capacitors are restored to 20°C after exposing them for 1,000 hours at 85°C without voltage applied. The rated voltage shall be applied to the capacitors for a minimum of 30 minutes, at least 24 hours and not more than 48 hours before the measurements.</p> <p>Capacitance change ≤ ±20% of the initial value Tan δ ≤ 200% of the initial specified value Leakage current ≤ The initial specified value</p>																		
Others	Satisfied characteristics KS C IEC 60384-4																		

RATINGS OF GSA-BP Series

µF \ V _{DC}	6.3	10	16	25	35	50
1						4×7 9.7
2.2					4×7 13	4×7 14
3.3				4×7 15	4×7 15	4×7 17
4.7			4×7 18	4×7 18	5×7 20	5×7 21
10		4×7 23	4×7 25	5×7 27	6.3×7 33	6.3×7 35
22	4×7 31	4×7 35	5×7 39	6.3×7 44		
33	5×7 40	5×7 48	6.3×7 49			
47	6.3×7 49	6.3×7 53				

Rated Ripple Current(mArms/85°C, 120Hz)
 Case Size ø D × L(mm)

DIMENSIONS OF GSA-BP Series

Unit(mm)

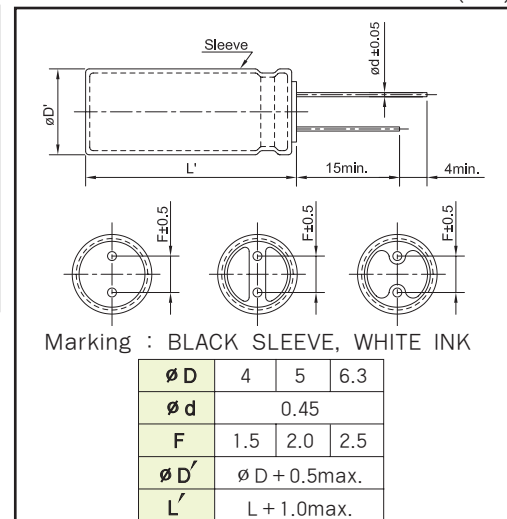

MHA-BP Series

• 85°C 2,000Hrs assured.

- Non-solvent proof.
- Bi-polarized.
- For Digital Household Appliances.
- RoHS compliant.
- Halogen-free capacitors are also available.

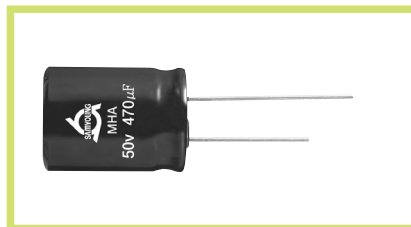
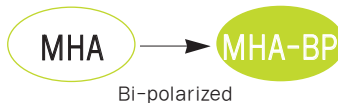

SPECIFICATIONS

Item	Characteristics																						
Rated Voltage Range	6.3 ~ 100 V _{DC}	160 ~ 250 V _{DC}																					
Operating Temperature Range	-40 ~ +85°C	-25 ~ +85°C																					
Capacitance Tolerance	±20% (M) (at 20°C, 120Hz)																						
Leakage Current (In both directions)	$I = 0.03CV(\mu A)$ or $3\mu A$, whichever is greater. Where, I:Max. Leakage current(μA), C:Nominal capacitance(μF), V:Rated voltage(V _{DC}) (at 20°C, 5 minutes)																						
Dissipation Factor (Tan δ)	<table border="1"> <thead> <tr> <th>Rated Voltage(V_{DC})</th> <th>6.3</th> <th>10</th> <th>16~25</th> <th>35</th> <th>50</th> <th>63~100</th> <th>160</th> <th>200~250</th> </tr> </thead> <tbody> <tr> <td>Tanδ(Max.)</td> <td>0.25</td> <td>0.24</td> <td>0.20</td> <td>0.16</td> <td>0.14</td> <td>0.12</td> <td>0.15</td> <td>0.20</td> </tr> </tbody> </table> When the capacitance exceeds 1,000 μF , 0.02 shall be added every 1,000 μF increase. (at 20°C, 120Hz)		Rated Voltage(V _{DC})	6.3	10	16~25	35	50	63~100	160	200~250	Tan δ (Max.)	0.25	0.24	0.20	0.16	0.14	0.12	0.15	0.20			
Rated Voltage(V _{DC})	6.3	10	16~25	35	50	63~100	160	200~250															
Tan δ (Max.)	0.25	0.24	0.20	0.16	0.14	0.12	0.15	0.20															
Temperature Characteristics (Max. Impedance ratio)	<table border="1"> <thead> <tr> <th>Rated Voltage(V_{DC})</th> <th>6.3</th> <th>10</th> <th>16</th> <th>25~100</th> <th>160</th> <th>200~250</th> </tr> </thead> <tbody> <tr> <td>Z(-25°C)/Z(20°C)</td> <td>4</td> <td>3</td> <td>2</td> <td>2</td> <td>4</td> <td>6</td> </tr> <tr> <td>Z(-40°C)/Z(20°C)</td> <td>10</td> <td>8</td> <td>6</td> <td>4</td> <td>-</td> <td>-</td> </tr> </tbody> </table> (at 120Hz)		Rated Voltage(V _{DC})	6.3	10	16	25~100	160	200~250	Z(-25°C)/Z(20°C)	4	3	2	2	4	6	Z(-40°C)/Z(20°C)	10	8	6	4	-	-
Rated Voltage(V _{DC})	6.3	10	16	25~100	160	200~250																	
Z(-25°C)/Z(20°C)	4	3	2	2	4	6																	
Z(-40°C)/Z(20°C)	10	8	6	4	-	-																	
Load Life	The following specifications shall be satisfied when the capacitors are restored to 20°C after the rated voltage is applied for 2,000 hours at 85°C. During this test, the rated voltage shall be reversed on the capacitor every 250 hours. Capacitance change $\leq \pm 20\%$ of the initial value (where, $\pm 25\%$ for ≤ 16 V _{DC}) Tan δ $\leq 200\%$ of the initial specified value Leakage current \leq The initial specified value																						
Shelf Life	The following specifications shall be satisfied when the capacitors are restored to 20°C after exposing them for 1,000 hours at 85°C without voltage applied. The rated voltage shall be applied to the capacitors for a minimum of 30 minutes, at least 24 hours and not more than 48 hours before the measurements. Capacitance change $\leq \pm 20\%$ of the initial value (where, $\pm 25\%$ for ≤ 16 V _{DC}) Tan δ $\leq 200\%$ of the initial specified value Leakage current $\leq 200\%$ of the initial specified value																						
Others	Satisfied characteristics KS C IEC 60384-4																						

DIMENSIONS OF MHA-BP Series

Unit(mm)

Marking : BLACK SLEEVE, WHITE INK

	5	6.3	8	10	12.5	16	18
øD	5	6.3	8	10	12.5	16	18
ød	0.5	0.5	0.6	0.6	0.6	0.8	0.8
F	2.0	2.5	3.5	5.0	5.0	7.5	7.5
øD'	øD + 0.5 max.						
L'	L + 1.5 max.			L + 2.0 max.			

RATINGS OF MHA-BP Series

μF \ Vdc	6.3		10		16		25		35		50	
10									5×11	50	5×11	52
22							5×11	66	6.3×11	71	6.3×11	89
33							6.3×11	90	6.3×11	104	8×11.5	124
47			5×11	86	5×11	89	6.3×11	107	8×11.5	142	10×12.5	174
100	5×11	126	6.3×11	144	6.3×11	148	8×11.5	179	10×12.5	244	10×16	284
220	6.3×11	213	8×11.5	244	10×12.5	295	10×16	345	10×20	432	12.5×20	500
330	8×11.5	298	10×12.5	352	10×16	399	10×20	458	12.5×20	543	16×20	666
470	10×12.5	420	10×16	463	10×20	515	12.5×20	606	12.5×25	704	16×25	877
1,000	10×20	732	12.5×20	791	12.5×25	882	16×20	961	16×31.5	1,223	18×35.5	1,409
2,200	12.5×25	1,291	16×20	1,275	16×31.5	1,557	18×31.5	1,699	18×40	1,838		
3,300	16×20	1,581	16×31.5	1,859	18×35.5	2,034	18×40	2,122				
4,700	16×31.5	2,219	18×31.5	2,290								
6,800	18×31.5	2,754	18×40	2,890								

μF \ Vdc	63		100		160		200		250	
3.3			5×11	35					10×12.5	48
4.7	5×11	40	6.3×11	48			10×12.5	58	10×16	65
10	6.3×11	63	8×11.5	80	10×16	104	10×20	96	12.5×20	107
22	8×11.5	106	10×12.5	140	12.5×20	185	12.5×25	180	16×20	190
33	8×11.5	137	10×16	189	12.5×25	247	16×20	239	16×25	257
47	10×12.5	183	10×20	244	16×25	325	16×25	325	18×31.5	324
100	10×20	327	12.5×25	430	18×31.5	450	18×40	496		
220	12.5×25	585	16×31.5	759						
330	16×25	791	18×35.5	934						
470	16×31.5	992								
1,000	18×40	1,431								

Rated Ripple Current(mArms/85°C, 120Hz)
 Case Size $\varnothing D \times L$ (mm)

NHA-BP Series

• 105°C 1,000Hrs assured.

- Bi-polarized.
- For Digital Household Appliances.
- RoHS compliant.
- Halogen-free capacitors are also available.

Solvent-proof

WV ≤ 100V_{DC}

NHA

NHA-BP

Bi-polarized



SPECIFICATIONS

Item	Characteristics																			
Rated Voltage Range	6.3 ~ 100 V _{DC}	160 ~ 250 V _{DC}																		
Operating Temperature Range	-55 ~ +105°C	-40 ~ +105°C																		
Capacitance Tolerance	±20% (M) (at 20°C, 120Hz)																			
Leakage Current (In both directions)	I = 0.03CV(μA) or 3μA, whichever is greater. Where, I: Max. Leakage current(μA), C: Nominal capacitance(μF), V: Rated voltage(V _{DC}) (at 20°C, 5 minutes)																			
Dissipation Factor (Tanδ)	<table border="1"> <thead> <tr> <th>Rated Voltage(V_{DC})</th> <th>6.3</th> <th>10</th> <th>16~25</th> <th>35</th> <th>50</th> <th>63~100</th> <th>160</th> <th>200~250</th> </tr> </thead> <tbody> <tr> <td>Tanδ(Max.)</td> <td>0.25</td> <td>0.24</td> <td>0.20</td> <td>0.16</td> <td>0.14</td> <td>0.12</td> <td>0.15</td> <td>0.20</td> </tr> </tbody> </table> When the capacitance exceeds 1,000μF, 0.02 shall be added every 1,000μF increase. (at 20°C, 120Hz)		Rated Voltage(V _{DC})	6.3	10	16~25	35	50	63~100	160	200~250	Tanδ(Max.)	0.25	0.24	0.20	0.16	0.14	0.12	0.15	0.20
Rated Voltage(V _{DC})	6.3	10	16~25	35	50	63~100	160	200~250												
Tanδ(Max.)	0.25	0.24	0.20	0.16	0.14	0.12	0.15	0.20												
Temperature Characteristics (Max. Impedance ratio)	<table border="1"> <thead> <tr> <th>Rated Voltage(V_{DC})</th> <th>6.3</th> <th>10</th> <th>16</th> <th>25~100</th> <th>160~250</th> </tr> </thead> <tbody> <tr> <td>Z(-25°C)/Z(20°C)</td> <td>4</td> <td>3</td> <td>2</td> <td>2</td> <td>3</td> </tr> <tr> <td>Z(-40°C)/Z(20°C)</td> <td>8</td> <td>6</td> <td>4</td> <td>3</td> <td>4</td> </tr> </tbody> </table> (at 120Hz)		Rated Voltage(V _{DC})	6.3	10	16	25~100	160~250	Z(-25°C)/Z(20°C)	4	3	2	2	3	Z(-40°C)/Z(20°C)	8	6	4	3	4
Rated Voltage(V _{DC})	6.3	10	16	25~100	160~250															
Z(-25°C)/Z(20°C)	4	3	2	2	3															
Z(-40°C)/Z(20°C)	8	6	4	3	4															
Load Life	The following specifications shall be satisfied when the capacitors are restored to 20°C after the rated voltage is applied for 1,000 hours at 105°C. During this test, the rated voltage shall be reversed on the capacitor every 250 hours. Capacitance change ≤ ±20% of the initial value (where, ±25% for ≤ 16 V _{DC}) Tanδ ≤ 150% of the initial specified value Leakage current ≤ The initial specified value																			
Shelf Life	The following specifications shall be satisfied when the capacitors are restored to 20°C after exposing them for 500 hours at 105°C without voltage applied. The rated voltage shall be applied to the capacitors for a minimum of 30 minutes, at least 24 hours and not more than 48 hours before the measurements. Capacitance change ≤ ±20% of the initial value (where, ±25% for ≤ 16 V _{DC}) Tanδ ≤ 150% of the initial specified value Leakage current ≤ 150% of the initial specified value																			
Others	Satisfied characteristics KS C IEC 60384-4																			

DIMENSIONS OF NHA-BP Series

Unit(mm)



Marking : BROWN SLEEVE, WHITE INK

	5	6.3	8	10	12.5	16	18
øD	5	6.3	8	10	12.5	16	18
ød	0.5	0.5	0.6	0.6	0.6	0.8	0.8
F	2.0	2.5	3.5	5.0	5.0	7.5	7.5
øD'	øD + 0.5 max.						
L'	L + 1.5 max.			L + 2.0 max.			

RATINGS OF NHA-BP Series

μF \ V _{DC}	6.3		10		16		25		35		50	
10									5×11	33	5×11	37
22							5×11	47	6.3×11	55	6.3×11	63
33							6.3×11	66	6.3×11	68	8×11.5	88
47			5×11	57	5×11	64	6.3×11	78	8×11.5	93	10×12.5	123
100	5×11	79	6.3×11	94	6.3×11	107	8×11.5	131	10×12.5	159	10×16	198
220	6.3×11	134	8×11.5	160	10×12.5	215	10×16	252	10×20	283	12.5×20	354
330	8×11.5	188	10×12.5	231	10×16	290	10×20	335	12.5×20	371	16×20	471
470	10×12.5	264	10×16	304	10×20	375	12.5×20	429	12.5×25	481	16×25	620
1,000	10×20	460	12.5×20	533	12.5×25	623	16×20	679	16×31.5	836	18×35.5	996
2,200	12.5×25	823	16×20	859	16×31.5	1,101	18×31.5	1,238	18×40	1,342		
3,300	16×20	1,008	16×31.5	1,253	18×35.5	1,438	18×40	1,592				
4,700	16×31.5	1,432	18×31.5	1,544								
6,800	18×31.5	1,778	18×40	1,949								

μF \ V _{DC}	63		100		160		200		250	
3.3			5×11	25					10×12.5	34
4.7	5×11	28	6.3×11	34			10×12.5	41	10×16	45
10	6.3×11	47	8×11.5	57	10×16	66	10×20	71	12.5×20	79
22	8×11.5	79	10×12.5	99	12.5×20	117	12.5×25	125	16×20	127
33	8×11.5	97	10×16	134	12.5×25	154	16×20	156	16×25	172
47	10×12.5	136	10×20	173	16×25	206	16×25	206	18×31.5	229
100	10×20	238	12.5×25	304	18×31.5	334	18×40	350		
220	12.5×25	403	16×31.5	537						
330	16×25	545	18×35.5	661						
470	16×31.5	702								
1,000	18×40	1,108								



 Rated Ripple Current(mArms/105°C, 120Hz)

 Case Size $\varnothing D \times L$ (mm)

NXL(LXV) Series

• 105°C 2,000~5,000Hrs assured.

- Low Impedance.
- For SMPS, IP-Board, Adaptor.
- RoHS compliant.
- Halogen-free capacitors are also available.

Solvent-proof

KXL → NXL(LXV)

Low Imp. Long Life



SPECIFICATIONS

Item	Characteristics																		
Rated Voltage Range	6.3 ~ 100 V _{DC}																		
Operating Temperature Range	-55 ~ +105°C																		
Capacitance Tolerance	±20%(M) (at 20°C, 120Hz)																		
Leakage Current	I=0.01CV or 3μA, whichever is greater. Where, I: Max.Leakage current(μA) C: Nominal capacitance (μF) V: Rated voltage (V _{DC}) (at 20°C, 2 minutes)																		
Dissipation Factor (Tanδ)	<table border="1"> <tr> <td>Rated Voltage(V_{DC})</td> <td>6.3</td> <td>10</td> <td>16</td> <td>25</td> <td>35</td> <td>50</td> <td>63</td> <td>100</td> </tr> <tr> <td>Tanδ(Max.)</td> <td>0.22</td> <td>0.19</td> <td>0.16</td> <td>0.14</td> <td>0.12</td> <td>0.10</td> <td>0.08</td> <td>0.07</td> </tr> </table> <p>When the capacitance exceeds 1,000μF, 0.02 shall be added every 1,000μF increase. (at 20°C, 120Hz)</p>	Rated Voltage(V _{DC})	6.3	10	16	25	35	50	63	100	Tanδ(Max.)	0.22	0.19	0.16	0.14	0.12	0.10	0.08	0.07
Rated Voltage(V _{DC})	6.3	10	16	25	35	50	63	100											
Tanδ(Max.)	0.22	0.19	0.16	0.14	0.12	0.10	0.08	0.07											
Temperature Characteristics (Max. Impedance ratio)	<table border="1"> <tr> <td>Rated voltage(V_{DC})</td> <td>6.3</td> <td>10~100</td> </tr> <tr> <td>Capacitance change(Max.) : ΔC(-55°C)/C(20°C)</td> <td colspan="2">30%</td> </tr> <tr> <td>Impedance ratio(Max.) : Z(-55°C)/Z(20°C)</td> <td>4</td> <td>3</td> </tr> </table> <p>(at 120Hz)</p>	Rated voltage(V _{DC})	6.3	10~100	Capacitance change(Max.) : ΔC(-55°C)/C(20°C)	30%		Impedance ratio(Max.) : Z(-55°C)/Z(20°C)	4	3									
Rated voltage(V _{DC})	6.3	10~100																	
Capacitance change(Max.) : ΔC(-55°C)/C(20°C)	30%																		
Impedance ratio(Max.) : Z(-55°C)/Z(20°C)	4	3																	
Load Life	<p>The following specifications shall be satisfied when the capacitors are restored to 20°C after the rated voltage with the rated ripple current is applied (the peak voltage shall not exceed the rated voltage) at 105°C for the specified period of time.</p> <table border="1"> <tr> <td>Capacitance change</td> <td>≦ ±20% of the initial value</td> <td>∅ D</td> <td>Life Time</td> </tr> <tr> <td>Tanδ</td> <td>≦ 200% of the initial specified value</td> <td>∅ 5, 6.3</td> <td>2,000 hours</td> </tr> <tr> <td>Leakage current</td> <td>≦ The initial specified value</td> <td>∅ 8, 10</td> <td>3,000 hours</td> </tr> <tr> <td></td> <td></td> <td>∅ 12.5~</td> <td>5,000 hours</td> </tr> </table>	Capacitance change	≦ ±20% of the initial value	∅ D	Life Time	Tanδ	≦ 200% of the initial specified value	∅ 5, 6.3	2,000 hours	Leakage current	≦ The initial specified value	∅ 8, 10	3,000 hours			∅ 12.5~	5,000 hours		
Capacitance change	≦ ±20% of the initial value	∅ D	Life Time																
Tanδ	≦ 200% of the initial specified value	∅ 5, 6.3	2,000 hours																
Leakage current	≦ The initial specified value	∅ 8, 10	3,000 hours																
		∅ 12.5~	5,000 hours																
Shelf Life	<p>The following specifications shall be satisfied when the capacitors are restored to 20°C after exposing them for 1,000 hours at 105°C without voltage applied. The rated voltage shall be applied to the capacitors for a minimum of 30 minutes, at least 24 hours and not more than 48 hours before the measurements.</p> <p>Capacitance change ≦ ±20% of the initial value Tanδ ≦ 200% of the initial specified value Leakage current ≦ The initial specified value</p>																		
Others	Satisfied characteristics KS C IEC 60384-4																		

DIMENSIONS OF NXL(LXV) Series

Unit(mm)

Marking : DARK BROWN SLEEVE, SILVER INK

∅D	5	6.3	8	10	12.5	16	18
∅d	0.5	0.5	0.6	0.6	0.6	0.8	0.8
F	2.0	2.5	3.5	5.0	5.0	7.5	7.5
∅D'	∅D + 0.5 max.						
L'	L + 1.5 max.			L + 2.0 max.			

※ ∅10 x 12L, L' ≦ L+1.5

RATINGS OF NXL(LXV) Series

V _{dc} μF	6.3				V _{dc} μF	10				V _{dc} μF	16			
	∅ D × L (mm)	IMP.		Ripple		∅ D × L (mm)	IMP.		Ripple		∅ D × L (mm)	IMP.		Ripple
		20°C	-10°C				20°C	-10°C				20°C	-10°C	
120	5 × 11	0.72	1.8	165	82	5 × 11	0.72	1.8	165	56	5 × 11	0.72	1.8	165
220	6.3 × 11	0.38	0.95	255	180	6.3 × 11	0.38	0.95	255	120	6.3 × 11	0.38	0.95	255
330	6.3 × 15	0.27	0.68	330	270	6.3 × 15	0.27	0.68	330	180	6.3 × 15	0.27	0.68	330
330	8 × 11.5	0.19	0.48	485	270	8 × 11.5	0.19	0.48	485	180	8 × 11.5	0.19	0.48	485
470	10 × 12	0.12	0.30	625	470	8 × 11.5	0.27	0.68	330	270	10 × 12	0.12	0.30	625
470	10 × 12.5	0.12	0.30	625						270	10 × 12.5	0.12	0.30	625
560	8 × 15	0.16	0.40	495	470	8 × 15	0.16	0.40	495	330	8 × 15	0.16	0.40	495
680	10 × 16	0.084	0.21	825	680	8 × 20	0.11	0.28	640	470	8 × 20	0.11	0.28	640
820	8 × 20	0.110	0.28	640	680	10 × 16	0.084	0.21	825	470	10 × 16	0.084	0.21	825
1,200	10 × 20	0.062	0.16	1,040	1,000	10 × 20	0.062	0.16	1,040	680	10 × 20	0.062	0.16	1,040
1,500	10 × 25	0.052	0.13	1,260	1,200	10 × 25	0.052	0.13	1,260	820	10 × 25	0.052	0.13	1,260
2,200	10 × 30	0.044	0.11	1,440	1,500	10 × 30	0.044	0.11	1,440	1,200	10 × 30	0.044	0.11	1,440
2,200	12.5 × 20	0.046	0.12	1,340	1,800	12.5 × 20	0.046	0.12	1,340	1,200	12.5 × 20	0.046	0.12	1,340
2,700	12.5 × 25	0.034	0.085	1,690	2,200	12.5 × 25	0.034	0.085	1,690	1,500	12.5 × 25	0.034	0.085	1,690
3,900	12.5 × 30	0.030	0.075	1,950	2,700	12.5 × 30	0.030	0.075	1,950	2,200	12.5 × 30	0.030	0.075	1,950
3,900	16 × 20	0.039	0.098	1,630	3,300	12.5 × 35	0.027	0.068	2,200	2,200	16 × 20	0.039	0.098	1,630
4,700	12.5 × 35	0.027	0.068	2,200	3,300	16 × 20	0.039	0.098	1,630	2,700	12.5 × 35	0.027	0.068	2,200
5,600	12.5 × 42.5	0.024	0.060	2,390	3,900	12.5 × 42.5	0.024	0.060	2,390	2,700	16 × 25	0.029	0.072	2,070
5,600	16 × 25	0.029	0.072	2,070	3,900	16 × 25	0.029	0.072	2,070	3,300	12.5 × 42.5	0.024	0.060	2,390
5,600	18 × 20	0.038	0.095	1,750	3,900	18 × 20	0.038	0.095	1,750	3,300	18 × 20	0.038	0.095	1,750
6,800	16 × 31.5	0.026	0.066	2,350	5,600	16 × 31.5	0.026	0.066	2,350	3,900	16 × 31.5	0.026	0.066	2,350
6,800	18 × 25	0.029	0.073	2,130	5,600	18 × 25	0.029	0.073	2,130	3,900	18 × 25	0.029	0.073	2,130
8,200	16 × 35.5	0.023	0.058	2,550	6,800	16 × 35.5	0.023	0.058	2,550	4,700	16 × 35.5	0.023	0.058	2,550
10,000	18 × 31.5	0.026	0.065	2,410	6,800	18 × 31.5	0.026	0.065	2,410	5,600	18 × 31.5	0.026	0.065	2,410
12,000	18 × 35.5	0.023	0.058	2,660	8,200	18 × 35.5	0.023	0.058	2,660	6,800	18 × 35.5	0.023	0.058	2,660
15,000	18 × 40	0.019	0.048	3,010	10,000	18 × 40	0.019	0.048	3,010	8,200	18 × 40	0.019	0.048	3,010

V _{dc} μF	25				V _{dc} μF	35				V _{dc} μF	50			
	∅ D × L (mm)	IMP.		Ripple		∅ D × L (mm)	IMP.		Ripple		∅ D × L (mm)	IMP.		Ripple
		20°C	-10°C				20°C	-10°C				20°C	-10°C	
										4.7	5 × 11	3.0	9.0	100
										10	5 × 11	1.40	4.2	124
39	5 × 11	0.72	1.8	165	27	5 × 11	0.72	1.8	165	18	5 × 11	1.10	3.3	130
47	5 × 11	0.72	1.8	194	47	6.3 × 11	0.50	1.25	233	22	6.3 × 11	0.91	2.6	180
82	6.3 × 11	0.38	0.95	255	56	6.3 × 11	0.38	0.95	255	39	6.3 × 11	0.56	1.6	220
100	6.3 × 11	0.35	0.88	280	68	6.3 × 11	0.38	0.95	255	47	6.3 × 11	0.56	1.6	300
120	6.3 × 15	0.27	0.68	330	82	6.3 × 15	0.27	0.68	330	56	6.3 × 15	0.41	1.2	310
120	8 × 11.5	0.19	0.48	485	82	8 × 11.5	0.19	0.48	485	56	8 × 11.5	0.33	0.96	368
180	10 × 12	0.12	0.30	625	120	10 × 12	0.12	0.30	625	82	8 × 15	0.25	0.75	470
180	10 × 12.5	0.12	0.30	625	120	10 × 12.5	0.12	0.30	625	82	10 × 12	0.16	0.40	480
220	8 × 15	0.16	0.40	495	180	8 × 15	0.16	0.40	495	82	10 × 12.5	0.16	0.40	480
330	8 × 20	0.11	0.28	640	220	8 × 20	0.11	0.28	640	120	8 × 20	0.18	0.52	610
330	10 × 16	0.084	0.21	825	220	10 × 16	0.084	0.21	825	120	10 × 16	0.12	0.30	755
470	10 × 20	0.062	0.16	1,150	330	10 × 20	0.062	0.16	1,040	180	10 × 20	0.088	0.22	945
560	10 × 25	0.052	0.13	1,260	390	10 × 25	0.052	0.13	1,260	220	10 × 25	0.068	0.17	1,150
820	10 × 30	0.044	0.11	1,440	560	10 × 30	0.044	0.11	1,440	330	10 × 30	0.059	0.15	1,260
820	12.5 × 20	0.046	0.12	1,340	560	12.5 × 20	0.046	0.12	1,340	330	12.5 × 20	0.059	0.15	1,190
1,000	12.5 × 25	0.034	0.085	1,690	680	12.5 × 25	0.034	0.085	1,690	470	12.5 × 25	0.045	0.11	1,490
1,500	12.5 × 30	0.030	0.075	1,950	1,000	12.5 × 25	0.040	0.10	1,690	560	12.5 × 30	0.039	0.098	1,720
1,500	16 × 20	0.039	0.098	1,630	1,000	12.5 × 30	0.030	0.075	1,950	680	12.5 × 35	0.038	0.096	1,890
1,800	12.5 × 35	0.027	0.068	2,200	1,200	12.5 × 35	0.027	0.068	2,200	680	16 × 20	0.044	0.12	1,420
1,800	16 × 25	0.029	0.073	2,070	1,200	16 × 25	0.029	0.073	2,070	820	12.5 × 42.5	0.029	0.073	2,030
2,200	12.5 × 42.5	0.024	0.060	2,390	1,500	12.5 × 42.5	0.024	0.060	2,390	820	16 × 25	0.034	0.085	1,880
2,200	18 × 20	0.038	0.095	1,750	1,500	18 × 20	0.038	0.095	1,750	820	18 × 20	0.041	0.103	1,520
2,700	16 × 31.5	0.026	0.066	2,350	1,800	16 × 31.5	0.026	0.066	2,350	1,000	16 × 31.5	0.030	0.076	1,250
2,700	18 × 25	0.029	0.073	2,130	1,800	18 × 25	0.029	0.073	2,130	1,000	18 × 25	0.032	0.080	1,930
3,300	16 × 35.5	0.023	0.058	2,550	2,200	16 × 35.5	0.023	0.058	2,550	1,200	16 × 35.5	0.026	0.065	2,320
3,300	18 × 31.5	0.026	0.065	2,410	2,200	18 × 31.5	0.026	0.065	2,410	1,500	18 × 31.5	0.028	0.070	2,200
3,900	18 × 35.5	0.023	0.058	2,660	2,700	18 × 35.5	0.023	0.058	2,660	1,800	18 × 35.5	0.025	0.063	2,400
4,700	18 × 40	0.019	0.048	3,010	3,300	18 × 40	0.019	0.048	3,010	2,200	18 × 40	0.022	0.055	2,610

RATINGS OF NXL(LXV) Series

μF	V_{DC}	63				μF	V_{DC}	100			
		$\phi D \times L(mm)$	IMP.		Ripple			$\phi D \times L(mm)$	IMP.		Ripple
			20°C	-10°C					20°C	-10°C	
1	5×11	31.5	79.6	53	1	5×11	14.7	39.5	53		
1.5	5×11	22.4	56.6	65	1.5	5×11	9.8	26.3	65		
2.2	5×11	15.2	38.4	78	2.2	5×11	5.4	14.5	78		
3.3	5×11	11.1	28.1	98	3.3	5×11	4.6	12.3	98		
4.7	5×11	10.8	27.3	115	4.7	5×11	3.9	10.5	115		
6.8	5×11	4.3	10.9	120	6.8	6.3×11	3.2	8.7	128		
10	5×11	2.9	7.3	134	10	6.3×11	1.7	4.6	154		
15	6.3×11	2.7	6.9	188	15	8×11.5	1.2	3.4	222		
22	6.3×11	1.36	3.5	228	22	8×11.5	0.82	2.3	270		
33	8×11.5	0.66	1.8	330	33	10×12	0.41	1.1	384		
47	10×12	0.58	1.7	327	33	10×12.5	0.41	1.1	384		
47	10×12.5	0.58	1.7	327	47	10×16	0.37	1.0	400		
68	10×16	0.36	0.88	431	68	10×20	0.27	0.73	470		
100	10×20	0.29	0.73	570	100	12.5×20	0.27	0.74	670		
150	10×25	0.20	0.51	765	150	12.5×25	0.21	0.57	894		
220	12.5×20	0.16	0.41	994	220	16×25	0.17	0.46	1,201		
330	12.5×25	0.10	0.26	1,327	330	16×31.5	0.11	0.30	1,471		
470	16×31.5	0.091	0.24	1,518	470	16×35.5	0.091	0.25	1,681		
680	16×35.5	0.065	0.19	2,060	680	18×40	0.072	0.19	2,122		
1,000	16×35.5	0.049	0.14	2,250	1,000	18×40	0.051	0.14	2,897		

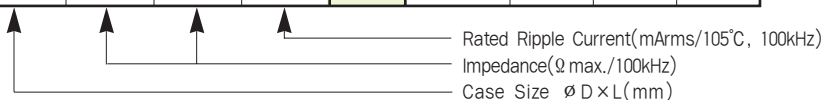

RATED RIPPLE CURRENT MULTIPLIERS

Frequency Multipliers

Rated Voltage (V_{DC})	ϕD (mm)	Freq.(Hz)				
		120	1k	10k	50k	100k
6.3~10	$\phi 5 \sim \phi 8$	0.65	0.83	0.95	0.97	1.00
	$\phi 10 \sim \phi 12.5$	0.70	0.85	0.96	0.98	1.00
	$\phi 16 \sim \phi 18$	0.85	0.92	0.97	0.99	1.00
16~25	$\phi 5 \sim \phi 8$	0.55	0.76	0.91	0.95	1.00
	$\phi 10 \sim \phi 12.5$	0.65	0.83	0.93	0.96	1.00
	$\phi 16 \sim \phi 18$	0.70	0.87	0.96	0.98	1.00
35~50	$\phi 5 \sim \phi 8$	0.40	0.66	0.85	0.90	1.00
	$\phi 10 \sim \phi 12.5$	0.50	0.73	0.89	0.94	1.00
	$\phi 16 \sim \phi 18$	0.60	0.81	0.94	0.97	1.00
63~100	$\phi 5 \sim \phi 8$	0.20	0.55	0.80	0.88	1.00
	$\phi 10 \sim \phi 12.5$	0.35	0.65	0.85	0.92	1.00
	$\phi 16 \sim \phi 18$	0.50	0.75	0.90	0.95	1.00

NXP(LXZ) Series

• 105°C 2,000 ~ 5,000Hrs assured.

- Low Impedance.
- For SMPS, IP-Board, Adaptor.
- RoHS compliant.
- Halogen-free capacitors are also available.
- AEC-Q200 compliant : Please contact us for more details, test data, information.

Solvent-proof

NXL (LXV)

NXP (LXZ)

Low Imp. Downsized



SPECIFICATIONS

Item	Characteristics														
Rated Voltage Range	6.3 ~ 50 V _{DC}														
Operating Temperature Range	-55 ~ +105°C														
Capacitance Tolerance	±20%(M) (at 20°C, 120Hz)														
Leakage Current	I = 0.01CV (µA) or 3µA, whichever is greater. Where, I:Max. Leakage current(µA) C:Nominal capacitance(µF) V:Rated voltage(V _{DC}) (at 20°C, 2 minutes)														
Dissipation Factor (Tanδ)	<table border="1"> <tr> <td>Rated Voltage(V_{DC})</td> <td>6.3</td> <td>10</td> <td>16</td> <td>25</td> <td>35</td> <td>50</td> </tr> <tr> <td>TANδ(Max.)</td> <td>0.22</td> <td>0.19</td> <td>0.16</td> <td>0.14</td> <td>0.12</td> <td>0.10</td> </tr> </table> <p>When the capacitance exceeds 1,000µF, 0.02 shall be added every 1,000µF increase. (at 20°C, 120Hz)</p>	Rated Voltage(V _{DC})	6.3	10	16	25	35	50	TANδ(Max.)	0.22	0.19	0.16	0.14	0.12	0.10
Rated Voltage(V _{DC})	6.3	10	16	25	35	50									
TANδ(Max.)	0.22	0.19	0.16	0.14	0.12	0.10									
Load Life	<p>The following specifications shall be satisfied when the capacitors are restored to 20°C after the rated voltage with the rated ripple current is applied (the peak voltage shall not exceed the rated voltage) at 105°C for the specified period of time.</p> <table border="1"> <tr> <td>Capacitance change</td> <td>≤ ±20% of the initial value</td> </tr> <tr> <td>Tanδ</td> <td>≤ 200% of the initial specified value</td> </tr> <tr> <td>Leakage Current</td> <td>≤ The initial specified value</td> </tr> </table> <table border="1"> <tr> <td>∅ D</td> <td>Life Time</td> </tr> <tr> <td>∅ 5, 6.3</td> <td>2,000 hours</td> </tr> <tr> <td>∅ 8</td> <td>3,000 hours</td> </tr> <tr> <td>∅ 10 ~</td> <td>5,000 hours</td> </tr> </table>	Capacitance change	≤ ±20% of the initial value	Tanδ	≤ 200% of the initial specified value	Leakage Current	≤ The initial specified value	∅ D	Life Time	∅ 5, 6.3	2,000 hours	∅ 8	3,000 hours	∅ 10 ~	5,000 hours
Capacitance change	≤ ±20% of the initial value														
Tanδ	≤ 200% of the initial specified value														
Leakage Current	≤ The initial specified value														
∅ D	Life Time														
∅ 5, 6.3	2,000 hours														
∅ 8	3,000 hours														
∅ 10 ~	5,000 hours														
Shelf Life	<p>The following specifications shall be satisfied when the capacitors are restored to 20°C after exposing them for 1,000 hours at 105°C without voltage applied. The rated voltage shall be applied to the capacitors for a minimum of 30 minutes, at least 24 hours and not more than 48 hours before the measurements.</p> <table border="1"> <tr> <td>Capacitance change</td> <td>≤ ±20% of the initial value</td> </tr> <tr> <td>Tanδ</td> <td>≤ 200% of the initial specified value</td> </tr> <tr> <td>Leakage Current</td> <td>≤ The initial specified value</td> </tr> </table>	Capacitance change	≤ ±20% of the initial value	Tanδ	≤ 200% of the initial specified value	Leakage Current	≤ The initial specified value								
Capacitance change	≤ ±20% of the initial value														
Tanδ	≤ 200% of the initial specified value														
Leakage Current	≤ The initial specified value														
Others	Satisfied characteristics KS C IEC 60384-4														

DIMENSIONS OF NXP(LXZ) Series

Unit(mm)

	<p>Marking : DARK BROWN SLEEVE, SILVER INK</p> <table border="1"> <tr> <td>∅D</td> <td>5</td> <td>6.3</td> <td>8</td> <td>10</td> <td>12.5</td> <td>16</td> <td>18</td> </tr> <tr> <td>∅d</td> <td>0.5</td> <td>0.5</td> <td>0.6</td> <td>0.6</td> <td>0.6</td> <td>0.8</td> <td>0.8</td> </tr> <tr> <td>F</td> <td>2.0</td> <td>2.5</td> <td>3.5</td> <td>5.0</td> <td>5.0</td> <td>7.5</td> <td>7.5</td> </tr> <tr> <td>∅D'</td> <td colspan="7">∅D + 0.5 max.</td> </tr> <tr> <td>L'</td> <td colspan="3">L + 1.5 max.</td> <td colspan="4">L + 2.0 max.</td> </tr> </table> <p>※ ∅10 x 12L, L' ≤ L + 1.5</p>	∅D	5	6.3	8	10	12.5	16	18	∅d	0.5	0.5	0.6	0.6	0.6	0.8	0.8	F	2.0	2.5	3.5	5.0	5.0	7.5	7.5	∅D'	∅D + 0.5 max.							L'	L + 1.5 max.			L + 2.0 max.			
∅D	5	6.3	8	10	12.5	16	18																																		
∅d	0.5	0.5	0.6	0.6	0.6	0.8	0.8																																		
F	2.0	2.5	3.5	5.0	5.0	7.5	7.5																																		
∅D'	∅D + 0.5 max.																																								
L'	L + 1.5 max.			L + 2.0 max.																																					

RATED RIPPLE CURRENT MULTIPLIERS

Frequency Multipliers

Cap.(µF) \ Freq.(Hz)	120	1k	10k	50k	100k
22 ~ 180	0.40	0.75	0.90	0.93	1.00
220 ~ 560	0.50	0.85	0.94	0.96	1.00
680 ~ 1,800	0.60	0.87	0.95	0.97	1.00
2,200 ~ 3,900	0.75	0.90	0.95	0.97	1.00
4,700 ~ 18,000	0.85	0.95	0.98	0.99	1.00

RATINGS OF NXP(LXZ) Series

V _{DC} ∅D×L(mm)	6.3				10				16			
	μF	IMP.		Ripple	μF	IMP.		Ripple	μF	IMP.		Ripple
		20°C	-10°C			20°C	-10°C			20°C	-10°C	
5 × 11	150	0.50	1.0	175	100	0.50	1.0	175	47	0.50	1.0	175
6.3 × 11	330	0.25	0.50	290	220	0.25	0.50	290	100	0.25	0.50	290
6.3 × 15	470	0.18	0.36	400	330	0.18	0.36	400	220	0.18	0.36	400
8 × 11.5	680	0.12	0.24	555	470	0.12	0.24	555	330	0.12	0.24	555
8 × 15	1,000	0.090	0.18	730	680	0.090	0.18	730	470	0.090	0.18	730
8 × 20	1,200	0.080	0.16	810	1,000	0.080	0.16	810	560	0.080	0.16	810
10 × 12	820	0.090	0.18	760	680	0.090	0.18	760	470	0.090	0.18	760
10 × 12.5	820	0.090	0.18	760	680	0.090	0.18	760	470	0.090	0.18	760
10 × 16	1,200	0.068	0.14	1,050	1,000	0.068	0.14	1,050	680	0.068	0.14	1,050
10 × 20	1,500	0.052	0.10	1,220	1,200	0.052	0.10	1,220	1,000	0.052	0.10	1,220
10 × 25	2,200	0.045	0.090	1,440	1,500	0.045	0.090	1,440	1,200	0.045	0.090	1,440
10 × 30	2,700	0.037	0.074	1,690	1,800	0.037	0.074	1,690	1,500	0.037	0.074	1,690
12.5 × 20	3,300	0.038	0.076	1,660	2,200	0.038	0.076	1,660	1,500	0.038	0.076	1,660
12.5 × 25	3,900	0.030	0.060	1,950	3,300	0.030	0.060	1,950	2,200	0.030	0.060	1,950
12.5 × 30	4,700	0.025	0.050	2,310	3,900	0.025	0.050	2,310	2,700	0.025	0.050	2,310
12.5 × 35	5,600	0.022	0.044	2,510	4,700	0.022	0.044	2,510	3,300	0.022	0.044	2,510
12.5 × 42.5	6,800	0.019	0.038	2,870	5,600	0.019	0.038	2,870	3,900	0.019	0.038	2,870
16 × 20	5,600	0.031	0.064	2,210	3,900	0.031	0.064	2,210	2,700	0.031	0.064	2,210
16 × 25	6,800	0.024	0.048	2,560	5,600	0.024	0.048	2,560	3,900	0.024	0.048	2,560
16 × 31.5	8,200	0.021	0.042	3,010	6,800	0.021	0.042	3,010	4,700	0.021	0.042	3,010
16 × 35.5	10,000	0.019	0.038	3,150	8,200	0.019	0.038	3,150	5,600	0.019	0.038	3,150
18 × 20	6,800	0.031	0.062	2,490	5,600	0.031	0.062	2,490	3,900	0.031	0.062	2,490
18 × 25	10,000	0.023	0.046	2,740	6,800	0.023	0.046	2,740	4,700	0.023	0.046	2,740
18 × 31.5	12,000	0.021	0.042	3,330	8,200	0.021	0.042	3,330	5,600	0.021	0.042	3,330
18 × 35.5	15,000	0.019	0.038	3,680	10,000	0.019	0.038	3,680	8,200	0.019	0.038	3,680
18 × 40	18,000	0.018	0.036	3,800	12,000	0.018	0.036	3,800	10,000	0.018	0.036	3,800

V _{DC} ∅D×L(mm)	25				35				50			
	μF	IMP.		Ripple	μF	IMP.		Ripple	μF	IMP.		Ripple
		20°C	-10°C			20°C	-10°C			20°C	-10°C	
5 × 11	47	0.50	1.0	175	33	0.50	1.0	175	22	0.70	1.4	155
6.3 × 11	82	0.30	0.60	260	47	0.25	0.50	265	33	0.45	0.90	170
6.3 × 11	100	0.25	0.50	290	56	0.25	0.50	290	47	0.45	0.90	180
6.3 × 15	150	0.18	0.36	400	100	0.18	0.36	400	68	0.31	0.62	360
8 × 11.5	220	0.12	0.24	555	150	0.12	0.24	555	100	0.18	0.36	485
8 × 15	330	0.090	0.18	730	220	0.090	0.18	730	120	0.16	0.32	635
8 × 20	390	0.080	0.16	810	270	0.080	0.16	810	180	0.12	0.24	730
10 × 12	330	0.090	0.18	760	220	0.090	0.18	760	120	0.16	0.32	620
10 × 12.5	330	0.090	0.18	760	220	0.090	0.18	760	120	0.16	0.32	620
10 × 16	470	0.068	0.14	1,050	330	0.068	0.14	1,050	180	0.13	0.26	850
	680	0.068	0.14	1,130								
10 × 20	680	0.052	0.10	1,220	470	0.052	0.11	1,220	220	0.088	0.18	1,050
	820	0.052	0.10	1,320								
10 × 25	820	0.045	0.090	1,440	560	0.045	0.090	1,440	330	0.073	0.15	1,250
10 × 30	1,000	0.037	0.074	1,690	680	0.037	0.074	1,690	390	0.054	0.11	1,500
12.5 × 20	1,000	0.038	0.076	1,660	680	0.038	0.076	1,660	390	0.059	0.12	1,480
12.5 × 25	1,500	0.030	0.060	1,950	1,000	0.030	0.060	1,950	560	0.044	0.088	1,840
					1,500	0.030	0.060	2,200				
12.5 × 30	1,800	0.025	0.050	2,310	1,200	0.025	0.050	2,310	680	0.039	0.078	2,220
12.5 × 35	2,200	0.022	0.044	2,510	1,500	0.022	0.044	2,510	820	0.033	0.066	2,290
12.5 × 42.5	2,700	0.019	0.038	2,870	1,800	0.019	0.038	2,870	1,000	0.029	0.058	2,500
16 × 20	1,800	0.031	0.064	2,210	1,200	0.031	0.064	2,210	680	0.048	0.096	1,840
16 × 25	2,700	0.024	0.048	2,560	1,800	0.024	0.048	2,560	1,000	0.034	0.068	2,240
16 × 31.5	3,300	0.021	0.042	3,010	2,200	0.021	0.042	3,010	1,200	0.028	0.056	2,700
16 × 35.5	3,900	0.019	0.038	3,150	2,700	0.019	0.038	3,150	1,500	0.026	0.052	2,800
18 × 20	2,200	0.031	0.062	2,490	1,800	0.031	0.100	2,490	820	0.042	0.084	1,980
18 × 25	3,300	0.023	0.046	2,740	2,200	0.023	0.046	2,740	1,200	0.029	0.058	2,610
18 × 31.5	3,900	0.021	0.042	3,330	2,700	0.021	0.042	3,330	1,800	0.027	0.054	2,750
18 × 35.5	4,700	0.019	0.038	3,680	3,300	0.019	0.038	3,680	2,200	0.025	0.050	2,900
18 × 40	5,600	0.018	0.036	3,800	3,900	0.018	0.036	3,800	2,700	0.022	0.044	3,200

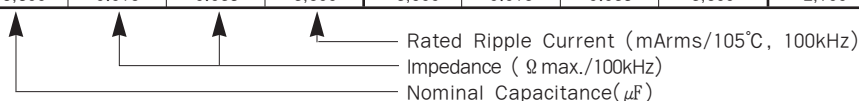

NXP(LXZ) Series

NXR Series

• 105°C 4,000 ~ 7,000Hrs assured.

- Low Impedance.
- For SMPS, IP-Board, Adaptor, Automotive equipment.
- RoHS compliant.
- Halogen-free capacitors are also available.
- AEC-Q200 compliant : Please contact us for more details, test data, information.

Solvent-proof

NXP (LXZ)

NXR

Low Imp. Downsized

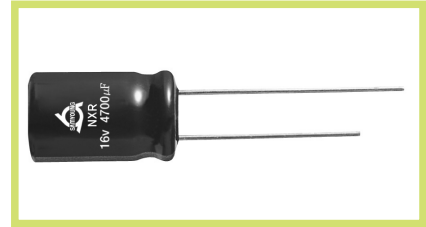

SPECIFICATIONS

Item	Characteristics														
Rated Voltage Range	6.3 ~ 35 V _{DC}														
Operating Temperature Range	-55 ~ +105°C														
Capacitance Tolerance	±20%(M) (at 20°C, 120Hz)														
Leakage Current	I = 0.01CV (μA) or 3μA, whichever is greater. Where, I:Max. Leakage current(μA) C:Nominal capacitance(μF) V:Rated voltage(V _{DC}) (at 20°C, 2 minutes)														
Dissipation Factor (Tanδ)	<table border="1"> <tr> <td>Rated Voltage(V_{DC})</td> <td>6.3</td> <td>10</td> <td>16</td> <td>25</td> <td>35</td> </tr> <tr> <td>TANδ(Max.)</td> <td>0.22</td> <td>0.19</td> <td>0.16</td> <td>0.14</td> <td>0.12</td> </tr> </table> <p>When the capacitance exceeds 1,000μF, 0.02 shall be added every 1,000μF increase. (at 20°C, 120Hz)</p>	Rated Voltage(V _{DC})	6.3	10	16	25	35	TANδ(Max.)	0.22	0.19	0.16	0.14	0.12		
Rated Voltage(V _{DC})	6.3	10	16	25	35										
TANδ(Max.)	0.22	0.19	0.16	0.14	0.12										
Temperature Characteristics (Capacitance change ratio)	<table border="1"> <tr> <td>Rated Voltage(V_{DC})</td> <td>6.3</td> <td>10</td> <td>16</td> <td>25</td> <td>35</td> </tr> <tr> <td>Z(-55°C)/Z(+20°C)</td> <td>4</td> <td>3</td> <td>3</td> <td>3</td> <td>3</td> </tr> </table> <p>(at 20°C, 120Hz)</p>	Rated Voltage(V _{DC})	6.3	10	16	25	35	Z(-55°C)/Z(+20°C)	4	3	3	3	3		
Rated Voltage(V _{DC})	6.3	10	16	25	35										
Z(-55°C)/Z(+20°C)	4	3	3	3	3										
Load Life	<p>The following specifications shall be satisfied when the capacitors are restored to 20°C after the rated voltage with the rated ripple current is applied (the peak voltage shall not exceed the rated voltage) at 105°C for the specified period of time.</p> <table border="1"> <tr> <td>Capacitance change</td> <td>≤ ±20% of the initial value</td> </tr> <tr> <td>Tanδ</td> <td>≤ 200% of the initial specified value</td> </tr> <tr> <td>Leakage Current</td> <td>≤ The initial specified value</td> </tr> </table> <table border="1"> <tr> <td>∅ D</td> <td>Life Time</td> </tr> <tr> <td>∅ 10</td> <td>4,000 hours</td> </tr> <tr> <td>∅ 12.5</td> <td>5,000 hours</td> </tr> <tr> <td>∅ 16, 18</td> <td>7,000 hours</td> </tr> </table>	Capacitance change	≤ ±20% of the initial value	Tanδ	≤ 200% of the initial specified value	Leakage Current	≤ The initial specified value	∅ D	Life Time	∅ 10	4,000 hours	∅ 12.5	5,000 hours	∅ 16, 18	7,000 hours
Capacitance change	≤ ±20% of the initial value														
Tanδ	≤ 200% of the initial specified value														
Leakage Current	≤ The initial specified value														
∅ D	Life Time														
∅ 10	4,000 hours														
∅ 12.5	5,000 hours														
∅ 16, 18	7,000 hours														
Shelf Life	<p>The following specifications shall be satisfied when the capacitors are restored to 20°C after exposing them for 1,000 hours at 105°C without voltage applied. The rated voltage shall be applied to the capacitors for a minimum of 30 minutes, at least 24 hours and not more than 48 hours before the measurements.</p> <p>Capacitance change ≤ ±20% of the initial value Tanδ ≤ 200% of the initial specified value Leakage Current ≤ The initial specified value</p>														
Others	Satisfied characteristics KS C IEC 60384-4														

DIMENSIONS OF NXR Series

Unit(mm)

Marking : DARK BROWN SLEEVE, SILVER INK

∅D	10	12.5	16	18
∅d	0.6	0.6	0.8	0.8
F	5.0	5.0	7.5	7.5
∅D'	∅D + 0.5 max.			
L'	L + 2.0 max.			

RATINGS OF NXR Series

V _{DC} ∅D×L(mm)	6.3			10			16		
	μF	IMP.	Ripple	μF	IMP.	Ripple	μF	IMP.	Ripple
10×12.5	1,500	0.063	960	1,000	0.063	960	820	0.063	960
10×16	2,200	0.049	1,240	1,800	0.049	1,240	1,200	0.049	1,240
10×20	3,300	0.035	1,550	2,200	0.035	1,550	1,800	0.035	1,550
10×25	3,900	0.033	1,740	2,700	0.033	1,740	2,200	0.033	1,740
12.5×20	4,700	0.029	1,890	3,900	0.029	1,890	2,700	0.029	1,890
12.5×25	5,600	0.022	2,350	4,700	0.022	2,350	3,300	0.022	2,350
16×20	6,800	0.026	2,330	4,700	0.026	2,330	3,900	0.026	2,330
18×20	8,200	0.025	2,640	6,800	0.025	2,640	5,600	0.025	2,640
16×25	10,000	0.019	2,760	6,800	0.019	2,760	5,600	0.019	2,760
18×25	12,000	0.018	2,850	8,200	0.018	2,850	8,200	0.018	2,850

V _{DC} ∅D×L(mm)	25			35		
	μF	IMP.	Ripple	μF	IMP.	Ripple
10×12.5	470	0.063	960	330	0.063	960
10×16	820	0.049	1,240	680	0.049	1,240
10×20	1,200	0.035	1,550	820	0.035	1,550
10×25	1,500	0.033	1,740	1,200	0.033	1,740
12.5×20	1,800	0.029	1,890	1,500	0.029	1,890
12.5×25	2,700	0.022	2,350	1,800	0.022	2,350
16×20	2,700	0.026	2,330	1,800	0.026	2,330
18×20	3,300	0.025	2,640	2,200	0.025	2,640
16×25	3,900	0.019	2,760	2,700	0.019	2,760
18×25	4,700	0.018	2,850	3,300	0.018	2,850

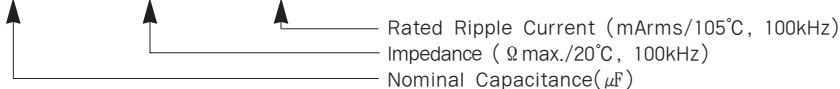

RATED RIPPLE CURRENT MULTIPLIERS

Frequency Multipliers

Cap.(μF) \ Freq.(Hz)	120	1k	10k	50k	100k
330 ~ 470	0.50	0.85	0.94	0.96	1.00
680 ~ 1,800	0.60	0.87	0.95	0.97	1.00
2,200 ~ 3,900	0.75	0.90	0.95	0.97	1.00
4,700 ~ 12,000	0.85	0.95	0.98	0.99	1.00

NXA Series

• 105°C 4,000 ~ 10,000Hrs assured.

- Non-solvent proof.
- Low Impedance, Long Life.
- For SMPS, IP-Board, Adaptor, Noise Filter, Charger.
- RoHS compliant.
- Halogen-free capacitors are also available.

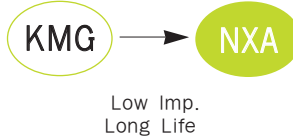

SPECIFICATIONS

Item	Characteristics																														
Rated Voltage Range	6.3 ~ 100 V _{DC}																														
Operating Temperature Range	-40 ~ +105°C																														
Capacitance Tolerance	±20%(M) (at 20°C, 120Hz)																														
Leakage Current	I = 0.01CV(μA) or 3μA, whichever is greater. Where, I:Max. Leakage current(μA), C:Nominal capacitance(μF), V:Rated voltage(V _{DC}) (at 20°C, 2 minutes)																														
Dissipation Factor(Tanδ)	<table border="1"> <tr> <td>Rated Voltage(V_{DC})</td> <td>6.3</td> <td>10</td> <td>16</td> <td>25</td> <td>35</td> <td>50</td> <td>63</td> <td>80</td> <td>100</td> </tr> <tr> <td>Tanδ(Max.)</td> <td>0.22</td> <td>0.19</td> <td>0.16</td> <td>0.14</td> <td>0.12</td> <td>0.10</td> <td>0.09</td> <td>0.09</td> <td>0.08</td> </tr> </table> <p>When the capacitance exceeds 1,000μF, 0.02 shall be added every 1,000μF increase. (at 20°C, 120Hz)</p>	Rated Voltage(V _{DC})	6.3	10	16	25	35	50	63	80	100	Tanδ(Max.)	0.22	0.19	0.16	0.14	0.12	0.10	0.09	0.09	0.08										
Rated Voltage(V _{DC})	6.3	10	16	25	35	50	63	80	100																						
Tanδ(Max.)	0.22	0.19	0.16	0.14	0.12	0.10	0.09	0.09	0.08																						
Temperature Characteristics (Max. Impedance ratio)	<table border="1"> <tr> <td>Rated Voltage(V_{DC})</td> <td>6.3</td> <td>10</td> <td>16</td> <td>25</td> <td>35</td> <td>50</td> <td>63</td> <td>80</td> <td>100</td> </tr> <tr> <td>Z(-25°C)/Z(+20°C)</td> <td>4</td> <td>3</td> <td>2</td> <td>2</td> <td>2</td> <td>2</td> <td>2</td> <td>2</td> <td>2</td> </tr> <tr> <td>Z(-40°C)/Z(+20°C)</td> <td>8</td> <td>6</td> <td>4</td> <td>3</td> <td>3</td> <td>3</td> <td>3</td> <td>3</td> <td>3</td> </tr> </table> <p>(at 120Hz)</p>	Rated Voltage(V _{DC})	6.3	10	16	25	35	50	63	80	100	Z(-25°C)/Z(+20°C)	4	3	2	2	2	2	2	2	2	Z(-40°C)/Z(+20°C)	8	6	4	3	3	3	3	3	3
Rated Voltage(V _{DC})	6.3	10	16	25	35	50	63	80	100																						
Z(-25°C)/Z(+20°C)	4	3	2	2	2	2	2	2	2																						
Z(-40°C)/Z(+20°C)	8	6	4	3	3	3	3	3	3																						
Load Life	<p>The following specifications shall be satisfied when the capacitors are restored to 20°C after the rated voltage with the rated ripple current is applied (the peak voltage shall not exceed the rated voltage) at 105°C for the specified period of time.</p> <table border="1"> <tr> <td></td> <td>V_{DC}</td> <td>ø5~ø6.3</td> <td>ø8~ø10</td> <td>ø12.5~ø18</td> </tr> <tr> <td>Capacitance change</td> <td>≤ ±25% of the initial value</td> <td>6.3~10(V)</td> <td>4,000 hours</td> <td>6,000 hours</td> </tr> <tr> <td>Tanδ</td> <td>≤ 200% of the initial specified value</td> <td>16~100(V)</td> <td>5,000 hours</td> <td>7,000 hours</td> </tr> <tr> <td>Leakage current</td> <td>≤ The initial specified value</td> <td></td> <td>8,000 hours</td> <td>10,000 hours</td> </tr> </table>		V _{DC}	ø5~ø6.3	ø8~ø10	ø12.5~ø18	Capacitance change	≤ ±25% of the initial value	6.3~10(V)	4,000 hours	6,000 hours	Tanδ	≤ 200% of the initial specified value	16~100(V)	5,000 hours	7,000 hours	Leakage current	≤ The initial specified value		8,000 hours	10,000 hours										
	V _{DC}	ø5~ø6.3	ø8~ø10	ø12.5~ø18																											
Capacitance change	≤ ±25% of the initial value	6.3~10(V)	4,000 hours	6,000 hours																											
Tanδ	≤ 200% of the initial specified value	16~100(V)	5,000 hours	7,000 hours																											
Leakage current	≤ The initial specified value		8,000 hours	10,000 hours																											
Shelf Life	<p>The following specifications shall be satisfied when the capacitors are restored to 20°C after exposing them for 500 hours at 105°C without voltage applied. The rated voltage shall be applied to the capacitors for a minimum of 30 minutes, at least 24 hours and not more than 48 hours before the measurements.</p> <p>Capacitance change ≤ ±25% of the initial value Tanδ ≤ 200% of the initial specified value Leakage current ≤ The initial specified value</p>																														
Others	Satisfied characteristics KS C IEC 60384-4																														

DIMENSIONS OF NXA Series

Unit(mm)

Marking : DARK BROWN SLEEVE, SILVER INK

øD	5	6.3	8	10	12.5	16	18
ød	0.5	0.5	0.6	0.6	0.6	0.8	0.8
F	2.0	2.5	3.5	5.0	5.0	7.5	7.5
øD'	øD + 0.5 max.						
L'	L + 1.5 max.			L + 2.0 max.			

※ ø10 x 12L, L' ≤ L + 1.5

RATINGS OF NXA Series

∅DXL(mm)	V _{DC}	6.3			10			16					
		μF	IMP.		Ripple	μF	IMP.		Ripple	μF	IMP.		Ripple
			20°C	-10°C			20°C	-10°C			20°C	-10°C	
5 × 11		150	0.58	2.3	210	100	0.58	2.3	210	56	0.58	2.3	210
6.3 × 11		330	0.22	0.87	340	220	0.22	0.87	340	120	0.22	0.87	340
8 × 11.5		680	0.130	0.52	640	470	0.130	0.52	640	330	0.130	0.52	640
8 × 15		1,000	0.087	0.35	840	680	0.087	0.35	840	470	0.087	0.35	840
8 × 20		1,200	0.069	0.27	1,050	1,000	0.069	0.27	1,050	680	0.069	0.27	1,050
10 × 12		820	0.080	0.32	865	680	0.080	0.32	865	470	0.080	0.32	865
10 × 12.5		820	0.080	0.32	865	680	0.080	0.32	865	470	0.080	0.32	865
10 × 16		1,200	0.060	0.24	1,210	1,000	0.060	0.24	1,210	680	0.060	0.24	1,210
10 × 20		1,500	0.046	0.18	1,400	1,200	0.046	0.18	1,400	1,000	0.046	0.18	1,400
10 × 25		2,200	0.042	0.17	1,650	1,500	0.042	0.17	1,650	1,200	0.042	0.17	1,650
10 × 30		2,700	0.031	0.12	1,910	2,200	0.031	0.12	1,910	1,500	0.031	0.12	1,910
12.5 × 16		1,800	0.049	0.16	1,450	1,500	0.049	0.16	1,450	1,000	0.049	0.16	1,450
12.5 × 20		3,300	0.035	0.12	1,900	2,200	0.035	0.12	1,900	1,500	0.035	0.12	1,900
12.5 × 25		3,900	0.027	0.089	2,230	3,300	0.027	0.089	2,230	2,200	0.027	0.089	2,230
12.5 × 30		4,700	0.024	0.078	2,650	3,900	0.024	0.078	2,650	2,700	0.024	0.078	2,650
12.5 × 35		5,600	0.020	0.065	2,880	4,700	0.020	0.065	2,880	3,300	0.020	0.065	2,880
16 × 15		2,700	0.042	0.12	1,940	2,200	0.042	0.12	1,940	1,500	0.042	0.12	1,940
16 × 20		5,600	0.027	0.078	2,530	3,900	0.027	0.078	2,530	2,700	0.027	0.078	2,530
16 × 25		6,800	0.021	0.060	2,930	5,600	0.021	0.06	2,930	3,900	0.021	0.06	2,930
16 × 31.5		8,200	0.017	0.050	3,450	6,800	0.017	0.05	3,450	4,700	0.017	0.05	3,450
16 × 35.5		10,000	0.015	0.044	3,610	8,200	0.015	0.044	3,610	5,600	0.015	0.044	3,610
16 × 40		12,000	0.013	0.038	4,080	10,000	0.013	0.038	4,080	6,800	0.013	0.038	4,080
18 × 20		6,800	0.026	0.067	2,860	5,600	0.026	0.067	2,860	3,900	0.026	0.067	2,860
18 × 25		10,000	0.019	0.049	3,140	6,800	0.019	0.049	3,140	4,700	0.019	0.049	3,140
18 × 31.5		12,000	0.017	0.047	4,170	8,200	0.017	0.047	4,170	5,600	0.017	0.047	4,170
18 × 35.5		15,000	0.016	0.045	4,220	10,000	0.016	0.045	4,220	8,200	0.016	0.045	4,220
18 × 40		18,000	0.015	0.043	4,280	12,000	0.015	0.043	4,280	10,000	0.015	0.043	4,280

∅DXL(mm)	V _{DC}	25			35			50					
		μF	IMP.		Ripple	μF	IMP.		Ripple	μF	IMP.		Ripple
			20°C	-10°C			20°C	-10°C			20°C	-10°C	
5 × 11		47	0.58	2.3	210	33	0.58	2.3	210	1	4.0	16.0	50
										2.2	2.5	10.0	51
										3.3	2.2	8.8	53
										4.7	3.0	12.0	80
										10	1.5	6.0	100
6.3 × 11		100	0.22	0.87	340	56	0.22	0.87	340	22	0.70	2.8	180
										22	0.30	1.2	295
										47	0.30	1.2	340
8 × 11.5		220	0.13	0.52	640	150	0.13	0.52	640	100	0.17	0.68	555
8 × 15		330	0.087	0.35	840	220	0.087	0.35	840	120	0.12	0.48	730
8 × 20		470	0.069	0.27	1,050	270	0.069	0.27	1,050	180	0.090	0.36	910
10 × 12		330	0.080	0.32	865	220	0.080	0.32	865	150	0.12	0.48	760
10 × 12.5		330	0.080	0.32	865	220	0.080	0.32	865	150	0.12	0.48	760
10 × 16		470	0.060	0.24	1,210	330	0.060	0.24	1,210	220	0.084	0.34	1,050
10 × 20		680	0.046	0.18	1,400	470	0.046	0.18	1,400	270	0.060	0.24	1,220
10 × 25		820	0.042	0.17	1,650	560	0.042	0.17	1,650	330	0.055	0.22	1,440
10 × 30		1,000	0.031	0.12	1,910	680	0.031	0.12	1,910	470	0.043	0.17	1,690
12.5 × 16		680	0.049	0.16	1,450	470	0.049	0.16	1,450	270	0.061	0.20	1,260
12.5 × 20		1,000	0.035	0.12	1,900	680	0.035	0.12	1,900	470	0.045	0.15	1,660
12.5 × 25		1,500	0.027	0.089	2,230	1,000	0.027	0.089	2,230	560	0.034	0.11	1,950
12.5 × 30		1,800	0.024	0.078	2,650	1,200	0.024	0.078	2,650	680	0.030	0.10	2,310
12.5 × 35		2,200	0.020	0.065	2,880	1,500	0.020	0.065	2,880	820	0.025	0.083	2,510
16 × 15		1,000	0.042	0.12	1,940	680	0.042	0.12	1,940	470	0.055	0.17	1,690
16 × 20		1,800	0.027	0.078	2,530	1,200	0.027	0.078	2,530	820	0.034	0.10	2,210
16 × 25		2,700	0.021	0.060	2,930	1,800	0.021	0.060	2,930	1,000	0.025	0.075	2,555
16 × 31.5		3,300	0.017	0.050	3,450	2,200	0.017	0.050	3,450	1,200	0.022	0.066	3,010
16 × 35.5		3,900	0.015	0.044	3,610	2,700	0.015	0.044	3,610	1,500	0.019	0.057	3,150
16 × 40		4,700	0.013	0.038	4,080	3,300	0.013	0.038	4,080	1,800	0.016	0.048	3,710
18 × 20		2,200	0.026	0.067	2,860	1,800	0.026	0.067	2,860	1,000	0.036	0.097	2,490
18 × 25		3,300	0.019	0.049	3,140	2,200	0.019	0.049	3,140	1,200	0.026	0.070	2,740
18 × 31.5		3,900	0.017	0.047	4,170	2,700	0.017	0.047	4,170	1,800	0.021	0.057	3,635
18 × 35.5		4,700	0.016	0.045	4,220	3,300	0.016	0.045	4,220	2,200	0.017	0.046	3,680
18 × 40		5,600	0.015	0.043	4,280	3,900	0.015	0.043	4,280	2,700	0.016	0.045	3,800

RATINGS OF NXA Series

V _{DC} ∅D×L(mm)	63				80				100			
	μF	IMP.		Ripple	μF	IMP.		Ripple	μF	IMP.		Ripple
		20°C	-10°C			20°C	-10°C			20°C	-10°C	
5 × 11	15	0.88	3.5	165					4.7	1.5	6.0	105
									6.8	1.4	5.6	125
6.3 × 11	33	0.35	1.4	265					15	0.57	2.3	205
8 × 11.5	47	0.22	0.88	500					22	0.50	1.9	310
	56	0.22	0.88	500					27	0.36	1.4	355
8 × 15	82	0.16	0.64	665					39	0.25	1.0	450
8 × 20	120	0.12	0.48	820					68	0.19	0.76	565
10 × 12	82	0.11	0.44	690	68	0.17	0.66	480	47	0.17	0.66	480
10 × 12.5	82	0.11	0.44	690	68	0.17	0.66	480	47	0.17	0.66	480
10 × 16	120	0.076	0.31	950	100	0.11	0.47	600	68	0.11	0.47	600
10 × 20	180	0.056	0.23	1,150	120	0.084	0.34	800	82	0.084	0.34	800
									100	0.084	0.34	800
10 × 25	220	0.046	0.19	1,350	150	0.069	0.28	900	100	0.069	0.28	900
									120	0.069	0.28	900
12.5 × 16	180	0.072	0.29	1,150	150	0.11	0.34	750	100	0.11	0.34	750
12.5 × 20	270	0.041	0.13	1,500	220	0.062	0.18	1,100	150	0.062	0.18	1,100
12.5 × 25	390	0.031	0.093	1,900	330	0.047	0.14	1,250	220	0.047	0.14	1,250
12.5 × 30	470	0.028	0.084	2,300	390	0.042	0.13	1,500	270	0.042	0.13	1,500
12.5 × 35	560	0.024	0.072	2,500	470	0.036	0.11	1,650	330	0.036	0.11	1,650
									390	0.036	0.11	1,650
16 × 20	470	0.032	0.096	2,000	330	0.048	0.15	1,350	220	0.048	0.15	1,350
16 × 25	680	0.025	0.075	2,600	470	0.038	0.12	1,700	330	0.036	0.11	1,650
16 × 31.5	820	0.021	0.063	2,850	680	0.032	0.095	1,850	470	0.032	0.095	1,850
16 × 35.5	1,000	0.019	0.057	2,900	820	0.029	0.086	2,000	560	0.029	0.086	2,000
16 × 40	1,200	0.018	0.054	3,400	1,000	0.027	0.081	2,200	680	0.027	0.081	2,200
18 × 20	680	0.030	0.090	2,500	470	0.038	0.12	1,700	330	0.045	0.14	1,500
18 × 25	1,000	0.024	0.072	2,800	680	0.036	0.11	1,750	470	0.036	0.11	1,750
18 × 31.5	1,200	0.020	0.060	3,300	820	0.030	0.090	1,900	560	0.030	0.09	1,900
18 × 35.5	1,500	0.018	0.054	3,400	1,000	0.027	0.081	2,200	680	0.027	0.081	2,200
18 × 40	1,800	0.017	0.051	3,500	1,200	0.026	0.077	2,700	820	0.026	0.077	2,700

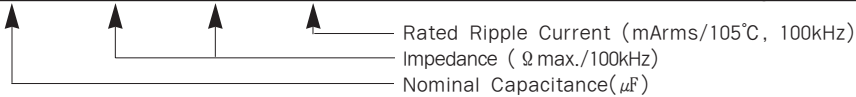

RATED RIPPLE CURRENT MULTIPLIERS

Frequency Multipliers

Freq.(Hz) Cap.(μF)	120	1k	10k	50K	100k
1 ~ 180	0.40	0.75	0.90	0.95	1.00
220 ~ 560	0.50	0.85	0.94	0.96	1.00
680 ~ 1,800	0.60	0.87	0.95	0.97	1.00
2,200 ~ 3,900	0.75	0.90	0.95	0.97	1.00
4,700 ~ 18,000	0.85	0.95	0.98	0.99	1.00

NXB Series

• 105°C 2,000~5,000Hrs assured.

- Non-solvent proof.
- Very Low Impedance.
- For SMPS, IP-Board, Adaptor, Noise Filter, Charger.
- RoHS compliant.
- Halogen-free capacitors are also available.

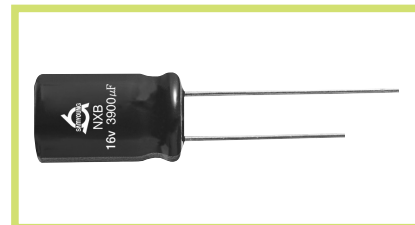

SPECIFICATIONS

Item	Characteristics																				
Rated Voltage Range	6.3 ~ 120 V _{DC}																				
Operating Temperature Range	-40 ~ +105°C																				
Capacitance Tolerance	±20%(M) (at 20°C, 120Hz)																				
Leakage Current	I = 0.01CV(μA) or 3μA, whichever is greater. Where, I:Max. Leakage current(μA), C:Nominal capacitance(μF), V:Rated voltage(V _{DC}) (at 20°C, 2 minutes)																				
Dissipation Factor(Tanδ)	<table border="1"> <tr> <td>Rated voltage(V_{DC})</td> <td>6.3</td> <td>10</td> <td>16</td> <td>25</td> <td>35</td> <td>50</td> <td>63</td> <td>100</td> <td>120</td> </tr> <tr> <td>Tanδ(Max)</td> <td>0.22</td> <td>0.19</td> <td>0.16</td> <td>0.14</td> <td>0.12</td> <td>0.10</td> <td>0.09</td> <td>0.08</td> <td>0.08</td> </tr> </table> <p>When the capacitance exceeds 1,000μF, 0.02 shall be added every 1,000μF increase. (at 20°C, 120Hz)</p>	Rated voltage(V _{DC})	6.3	10	16	25	35	50	63	100	120	Tanδ(Max)	0.22	0.19	0.16	0.14	0.12	0.10	0.09	0.08	0.08
Rated voltage(V _{DC})	6.3	10	16	25	35	50	63	100	120												
Tanδ(Max)	0.22	0.19	0.16	0.14	0.12	0.10	0.09	0.08	0.08												
Temperature Characteristics (Max. Impedance ratio)	<table border="1"> <tr> <td>Z(-25°C)/Z(20°C)</td> <td>2</td> </tr> <tr> <td>Z(-40°C)/Z(20°C)</td> <td>3</td> </tr> </table> <p>(at 120Hz)</p>	Z(-25°C)/Z(20°C)	2	Z(-40°C)/Z(20°C)	3																
Z(-25°C)/Z(20°C)	2																				
Z(-40°C)/Z(20°C)	3																				
Load Life	<p>The following specifications shall be satisfied when the capacitors are restored to 20°C after the rated voltage with the rated ripple current is applied (the peak voltage shall not exceed the rated voltage) at 105°C for the specified period of time.</p> <table border="1"> <tr> <td>∅ D</td> <td>Life Time</td> </tr> <tr> <td>∅ 5, 6.3</td> <td>2,000 hours</td> </tr> <tr> <td>∅ 8</td> <td>3,000 hours</td> </tr> <tr> <td>∅ 10</td> <td>4,000 hours</td> </tr> <tr> <td>∅ 12.5 ~</td> <td>5,000 hours</td> </tr> </table> <p>Capacitance change ≤ ±25% of the initial value Tanδ ≤ 200% of the initial specified value Leakage current ≤ The initial specified value</p>	∅ D	Life Time	∅ 5, 6.3	2,000 hours	∅ 8	3,000 hours	∅ 10	4,000 hours	∅ 12.5 ~	5,000 hours										
∅ D	Life Time																				
∅ 5, 6.3	2,000 hours																				
∅ 8	3,000 hours																				
∅ 10	4,000 hours																				
∅ 12.5 ~	5,000 hours																				
Shelf Life	<p>The following specifications shall be satisfied when the capacitors are restored to 20°C after exposing them for 1,000 hours at 105°C without voltage applied. The rated voltage shall be applied to the capacitors for a minimum of 30 minutes, at least 24 hours and not more than 48 hours before the measurements.</p> <p>Capacitance change ≤ ±25% of the initial value Tanδ ≤ 200% of the initial specified value Leakage current ≤ The initial specified value</p>																				
Others	Satisfied characteristics KS C IEC 60384-4																				

DIMENSIONS OF NXB Series

Unit(mm)

Marking : DARK BROWN SLEEVE, SILVER INK

∅D	5	6.3	8	10	12.5	16	18
∅d	0.5	0.5	0.6	0.6	0.6	0.8	0.8
F	2.0	2.5	3.5	5.0	5.0	7.5	7.5
∅D'	∅D + 0.5 max.						
L'	L + 1.5 max.			L + 2.0 max.			

※ ∅10 x 12L, L' ≤ L + 1.5



RATINGS OF NXB Series

V _{DC} ∅D×L(mm)	6.3				10				16			
	μF	IMP.		Ripple	μF	IMP.		Ripple	μF	IMP.		Ripple
		20°C	-10°C			20°C	-10°C			20°C	-10°C	
5 × 11	220	0.30	1.0	250	150	0.30	1.00	250	100	0.30	1.0	250
6.3 × 11	470	0.13	0.41	405	330	0.13	0.41	405	100	0.15	0.41	385
									220	0.13	0.36	405
6.3 × 15	560	0.10	0.32	646	470	0.10	0.32	646	330	0.10	0.32	646
8 × 11.5	820	0.072	0.22	760	330	0.094	0.28	600	470	0.072	0.22	760
					680	0.072	0.22	760				
8 × 15	1,200	0.060	0.18	818	1,000	0.060	0.18	818	680	0.060	0.18	818
8 × 20	1,500	0.050	0.16	1,260	1,200	0.050	0.16	1,260	1,000	0.050	0.16	1,260
10 × 12	1,200	0.053	0.16	1,360	820	0.053	0.16	1,360	680	0.053	0.16	1,360
					1000	0.053	0.16	1,360				
10 × 12.5	1,200	0.053	0.16	1,360	820	0.053	0.16	1,360	680	0.053	0.16	1,360
					1000	0.053	0.16	1,360				
10 × 16	1,800	0.038	0.12	1,430	1,000	0.038	0.12	1,430	1,000	0.038	0.12	1,430
					1,500	0.038	0.12	1,430				
10 × 20	2,200	0.023	0.069	1,820	1,500	0.023	0.069	1,820	1,500	0.023	0.069	1,820
10 × 25	3,300	0.022	0.066	2,150	2,200	0.022	0.066	2,150	1,800	0.022	0.066	2,150
12.5 × 16	1,800	0.031	0.078	1,452	1,500	0.031	0.078	1,452	1,000	0.031	0.078	1,452
12.5 × 20	3,900	0.021	0.053	2,360	3,300	0.021	0.053	2,360	2,200	0.021	0.053	2,360
12.5 × 25	4,700	0.020	0.050	2,770	3,900	0.020	0.050	2,770	2,700	0.020	0.050	2,770
12.5 × 30	5,600	0.018	0.046	3,290	4,700	0.018	0.046	3,290	3,300	0.018	0.046	3,290
12.5 × 35	6,800	0.017	0.044	3,400	5,600	0.017	0.044	3,400	3,900	0.017	0.044	3,400
16 × 15	2,700	0.040	0.101	1,375	1,800	0.040	0.101	1,375	1,200	0.040	0.101	1,375
16 × 20	5,600	0.021	0.053	3,140	4,700	0.021	0.053	3,140	3,300	0.021	0.053	3,140
16 × 25	6,800	0.019	0.051	3,460	5,600	0.019	0.051	3,460	4,700	0.019	0.051	3,460
16 × 31.5	8,200	0.013	0.035	3,680	6,800	0.013	0.035	3,680	5,600	0.013	0.035	3,680
18 × 20	5,600	0.020	0.052	3,265	4,700	0.020	0.052	3,265	3,300	0.020	0.052	3,265
18 × 25	8,200	0.018	0.049	3,611	5,600	0.018	0.049	3,611	3,900	0.018	0.049	3,611

V _{DC} ∅D×L(mm)	25				35				50							
	μF	IMP.		Ripple	μF	IMP.		Ripple	μF	IMP.		Ripple				
		20°C	-10°C			20°C	-10°C			20°C	-10°C					
5 × 11	68	0.30	1.0	250	47	0.30	1.0	250	1	2.50	8.68	53				
									2.2	2.50	8.68	56				
									4.7	1.50	5.21	82				
									10	1.0	3.47	250				
									22	0.30	1.04	250				
									27	0.30	1.04	250				
6.3 × 11	150	0.13	0.41	405	100	0.13	0.41	405	47	0.14	0.50	350				
									56	0.14	0.50	385				
6.3 × 15	220	0.10	0.32	646	150	0.10	0.32	646	100	0.10	0.32	646				
8 × 11.5	220	0.072	0.22	760	150	0.072	0.22	760	100	0.072	0.21	724				
8 × 15	390	0.060	0.18	818	270	0.060	0.18	818	120	0.060	0.24	818				
8 × 20	560	0.050	0.16	1,260	390	0.050	0.16	1,260	180	0.050	0.18	1,260				
10 × 12	330	0.053	0.16	1,360	220	0.053	0.16	1,360	150	0.061	0.18	979				
													470	0.053	0.16	1,360
10 × 12.5	330	0.053	0.16	1,360	220	0.053	0.16	1,360	150	0.061	0.18	979				
													470	0.053	0.16	1,360
10 × 16	470	0.038	0.12	1,430	470	0.038	0.12	1,430	220	0.042	0.12	1,370				
													680	0.038	0.12	1,430
10 × 20	680	0.023	0.069	1,820	560	0.023	0.069	1,820	330	0.030	0.090	1,580				
													820	0.023	0.069	2,000
													1,000	0.025	0.075	1,900
10 × 25	1,000	0.022	0.066	2,150	680	0.022	0.066	2,150	470	0.028	0.085	1,870				
12.5 × 16	680	0.031	0.078	1,452	470	0.031	0.078	1,452	270	0.042	0.078	1,071				
12.5 × 20	1,500	0.021	0.053	2,360	1,000	0.021	0.053	2,360	470	0.027	0.068	2,050				
12.5 × 25	1,800	0.020	0.050	2,770	1,000	0.020	0.050	2,770	560	0.023	0.059	2,410				
													2,200	0.020	0.050	3,000
12.5 × 30	2,200	0.018	0.046	3,290	1,500	0.018	0.046	3,290	680	0.021	0.052	2,860				
12.5 × 35	2,700	0.017	0.044	3,400	1,800	0.017	0.044	3,400	820	0.019	0.051	2,960				
16 × 15	820	0.040	0.101	1,375	560	0.040	0.101	1,375	390	0.046	0.114	1,196				
16 × 20	2,200	0.021	0.053	3,140	1,500	0.021	0.053	3,140	820	0.023	0.059	2,730				
					1,800	0.019	0.051	3,460								
16 × 25	3,300	0.019	0.051	3,460	2,200	0.019	0.051	3,460	1,000	0.021	0.056	3,010				
					2,200	0.019	0.051	3,460								
16 × 31.5	3,300	0.013	0.035	3,680	2,200	0.013	0.035	3,680	1,500	0.014	0.037	3,201				
18 × 20	2,200	0.020	0.052	3,265	1,500	0.020	0.052	3,265	1,000	0.022	0.059	2,850				
18 × 25	2,700	0.018	0.049	3,611	1,800	0.018	0.049	3,611	1,200	0.020	0.053	3,140				

RATINGS OF NXB Series

∅D×L(mm)	V _{DC}	63			
		μF	IMP.		Ripple
			20°C	-10°C	
5 × 11		10	0.45	1.8	165
6.3 × 11		33	0.30	1.2	265
6.3 × 15		47	0.25	1.0	420
8 × 11.5		47	0.20	0.80	500
		68	0.20	0.80	500
10 × 12		68	0.16	0.64	600
10 × 12.5		68	0.16	0.64	600
10 × 16		100	0.10	0.40	945
10 × 20		150	0.080	0.32	1,100
10 × 25		220	0.070	0.28	1,300
12.5 × 20		330	0.040	0.16	1,495
16 × 20		470	0.035	0.14	1,990
16 × 25		680	0.030	0.12	2,780
16 × 31.5		1,000	0.020	0.080	2,835

∅D×L(mm)	V _{DC}	100				120			
		μF	IMP.		Ripple	μF	IMP.		Ripple
			20°C	-10°C			20°C	-10°C	
5 × 11		3.3	2.0	8.0	125				
5 × 11		4.7	2.0	8.0	125				
6.3 × 11		10	0.50	2.0	205				
6.3 × 15		22	0.40	1.6	300				
8 × 11.5		22	0.30	1.2	355	22	0.30	1.2	472
10 × 12		33	0.25	1.0	450	33	0.25	1.0	599
10 × 12.5		33	0.25	1.0	450	33	0.25	1.0	599
10 × 16		47	0.20	0.80	580	47	0.20	0.80	771
12.5 × 20		100	0.10	0.40	1,045	100	0.10	0.40	1,400
12.5 × 25		150	0.070	0.28	1,195	120	0.070	0.28	1,589
16 × 25		220	0.060	0.24	1,600	220	0.060	0.24	2,128
16 × 31.5		330	0.040	0.16	1,750	270	0.040	0.16	2,328
		470	0.040	0.16	1,750				
18 × 40		820	0.030	0.12	2,060	560	0.036	0.144	2,740

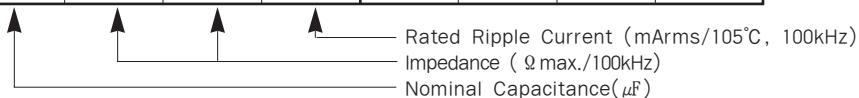

RIPPLE CURRENT MULTIPLIERS

Frequency Multipliers

Cap.(μF)	Freq.(Hz)	120	1k	10k	50k	100k
1 ~ 180	120	0.40	0.75	0.90	0.95	1.00
	220	0.50	0.85	0.94	0.96	1.00
	680	0.60	0.87	0.95	0.97	1.00
	2,200	0.75	0.90	0.95	0.97	1.00
	4,700	0.85	0.95	0.98	0.99	1.00

NXK Series

- 105°C 4,000~5,000Hrs assured.

- Non-solvent proof.
- Low Impedance.
- High Ripple.
- For LED TV BLU Inverter, SMPS, IP-Board, Adaptor.
- RoHS compliant.
- Halogen-free capacitors are also available.

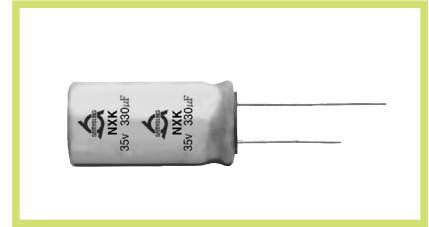
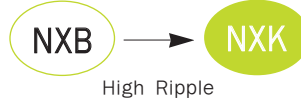

SPECIFICATIONS

Item	Characteristics																			
Rated Voltage Range	10 ~ 50 V _{DC}																			
Operating Temperature Range	-40 ~ + 105°C																			
Capacitance Tolerance	±20% (M) (at 20°C, 120Hz)																			
Leakage Current	I = 0.01CV(μA) or 3μA, whichever is greater. Where, I:Max. Leakage current(μA), C:Nominal capacitance(μF), V:Rated voltage(V _{DC}) (at 20°C, 2 minutes)																			
Dissipation Factor(Tanδ)	<table border="1"> <tr> <td>Rated Voltage(V_{DC})</td> <td>10</td> <td>16</td> <td>25</td> <td>35</td> <td>50</td> </tr> <tr> <td>Tanδ(Max.)</td> <td>0.19</td> <td>0.16</td> <td>0.14</td> <td>0.12</td> <td>0.10</td> </tr> </table> <p>When the capacitance exceeds 1,000μF, 0.02 shall be added every 1,000μF increase. (at 20°C, 120Hz)</p>	Rated Voltage(V _{DC})	10	16	25	35	50	Tanδ(Max.)	0.19	0.16	0.14	0.12	0.10							
Rated Voltage(V _{DC})	10	16	25	35	50															
Tanδ(Max.)	0.19	0.16	0.14	0.12	0.10															
Temperature Characteristics (Max. Impedance ratio)	<table border="1"> <tr> <td>Z(-25°C) / Z(+20°C)</td> <td>2</td> </tr> <tr> <td>Z(-40°C) / Z(+20°C)</td> <td>3</td> </tr> </table> <p>(at 120Hz)</p>	Z(-25°C) / Z(+20°C)	2	Z(-40°C) / Z(+20°C)	3															
Z(-25°C) / Z(+20°C)	2																			
Z(-40°C) / Z(+20°C)	3																			
Load Life	<p>The following specifications shall be satisfied when the capacitors are restored to 20°C after the rated voltage with the rated ripple current is applied (the peak voltage shall not exceed the rated voltage) at 105°C for the specified period of time.</p> <table border="1"> <tr> <td>Rated voltage(V_{DC})</td> <td>10</td> <td>16~50</td> <td>Case Size(∅D)</td> <td>Life Time</td> </tr> <tr> <td>Capacitance change</td> <td>≤ ±30% of the initial value</td> <td>≤ ±25% of the initial value</td> <td>∅ 8</td> <td rowspan="3">4,000Hrs</td> </tr> <tr> <td>Tanδ</td> <td colspan="2">≤ 200% of the initial specified value</td> <td>∅ 10x12 ~ 12.5L</td> </tr> <tr> <td>Leakage current</td> <td colspan="2">≤ The initial specified value</td> <td>∅ 10</td> <td>5,000Hrs</td> </tr> </table>	Rated voltage(V _{DC})	10	16~50	Case Size(∅D)	Life Time	Capacitance change	≤ ±30% of the initial value	≤ ±25% of the initial value	∅ 8	4,000Hrs	Tanδ	≤ 200% of the initial specified value		∅ 10x12 ~ 12.5L	Leakage current	≤ The initial specified value		∅ 10	5,000Hrs
Rated voltage(V _{DC})	10	16~50	Case Size(∅D)	Life Time																
Capacitance change	≤ ±30% of the initial value	≤ ±25% of the initial value	∅ 8	4,000Hrs																
Tanδ	≤ 200% of the initial specified value		∅ 10x12 ~ 12.5L																	
Leakage current	≤ The initial specified value		∅ 10		5,000Hrs															
Shelf Life	<p>The following specifications shall be satisfied when the capacitors are restored to 20°C after exposing them for 1,000 hours at 105°C without voltage applied. The rated voltage shall be applied to the capacitors for a minimum of 30 minutes, at least 24 hours and not more than 48 hours before the measurements.</p> <table border="1"> <tr> <td>Rated voltage(V_{DC})</td> <td>10</td> <td>16~50</td> </tr> <tr> <td>Capacitance change</td> <td>≤ ±30% of the initial value</td> <td>≤ ±25% of the initial value</td> </tr> <tr> <td>Tanδ</td> <td colspan="2">±200% of the initial specified value</td> </tr> <tr> <td>Leakage current</td> <td colspan="2">≤ The initial specified value</td> </tr> </table>	Rated voltage(V _{DC})	10	16~50	Capacitance change	≤ ±30% of the initial value	≤ ±25% of the initial value	Tanδ	±200% of the initial specified value		Leakage current	≤ The initial specified value								
Rated voltage(V _{DC})	10	16~50																		
Capacitance change	≤ ±30% of the initial value	≤ ±25% of the initial value																		
Tanδ	±200% of the initial specified value																			
Leakage current	≤ The initial specified value																			
Others	Satisfied characteristics KS C IEC 60384-4																			

DIMENSIONS OF NXK Series

Unit(mm)

Marking : YELLOW SLEEVE, BLACK INK

∅D	8	10
∅d	0.6	0.6
F	3.5	5.0
∅D'	∅D + 0.5 max.	
L'	L + 1.5 max. L + 2.0 max.	

※ ∅10 x 12L, L' ≤ L + 1.5

RATINGS OF NXK series

Vdc				
10				
Capacitance (μF)	ø D × L (mm)	Rated Ripple Current (mArms/105°C, 100kHz)	IMP.	
			(ρ max./20°C, 100kHz)	(ρ max./-10°C, 100kHz)
680	8 × 11.5	1,417	0.073	0.29
1,000	8 × 15	2,050	0.059	0.24
1,000	10 × 12	2,190	0.053	0.21
1,000	10 × 12.5	2,190	0.053	0.21
1,500	8 × 20	2,380	0.041	0.16
1,500	10 × 16	2,550	0.038	0.15
1,800	10 × 20	2,880	0.028	0.112
2,200	10 × 25	3,160	0.024	0.096
2,700	10 × 33	3,570	0.020	0.080

Vdc				
16				
Capacitance (μF)	ø D × L (mm)	Rated Ripple Current (mArms/105°C, 100kHz)	IMP.	
			(ρ max./20°C, 100kHz)	(ρ max./-10°C, 100kHz)
470	8 × 11.5	1,417	0.073	0.29
680	8 × 15	2,050	0.059	0.24
680	10 × 12	2,190	0.053	0.21
680	10 × 12.5	2,190	0.053	0.21
1,000	8 × 20	2,380	0.041	0.16
1,000	10 × 16	2,550	0.038	0.15
1,500	10 × 20	2,880	0.028	0.112
1,800	10 × 25	3,160	0.024	0.096
2,200	10 × 33	3,570	0.020	0.080

Vdc				
25				
Capacitance (μF)	ø D × L (mm)	Rated Ripple Current (mArms/105°C, 100kHz)	IMP.	
			(ρ max./20°C, 100kHz)	(ρ max./-10°C, 100kHz)
330	8 × 11.5	1,417	0.073	0.29
390	8 × 15	2,050	0.059	0.24
470	10 × 12	2,190	0.053	0.21
470	10 × 12.5	2,190	0.053	0.21
560	8 × 20	2,380	0.041	0.16
680	10 × 16	2,550	0.038	0.15
820	10 × 20	2,880	0.028	0.112
1,000	10 × 25	3,160	0.024	0.096
1,200	10 × 33	3,570	0.020	0.080

Vdc				
35				
Capacitance (μF)	ø D × L (mm)	Rated Ripple Current (mArms/105°C, 100kHz)	IMP.	
			(ρ max./20°C, 100kHz)	(ρ max./-10°C, 100kHz)
220	8 × 11.5	1,417	0.073	0.29
270	8 × 15	2,050	0.059	0.24
330	10 × 12	2,190	0.053	0.21
330	10 × 12.5	2,190	0.053	0.21
390	8 × 20	2,380	0.041	0.16
470	10 × 16	2,550	0.038	0.15
560	10 × 20	2,880	0.028	0.112
680	10 × 25	3,160	0.024	0.096
1,000	10 × 33	3,570	0.020	0.080

Vdc				
50				
Capacitance (μF)	ø D × L (mm)	Rated Ripple Current (mArms/105°C, 100kHz)	IMP.	
			(ρ max./20°C, 100kHz)	(ρ max./-10°C, 100kHz)
100	8 × 11.5	1,086	0.096	0.38
120	8 × 15	1,558	0.080	0.32
150	10 × 12	1,612	0.083	0.33
150	10 × 12.5	1,612	0.083	0.33
180	8 × 20	1,888	0.065	0.26
220	10 × 16	1,985	0.057	0.23
270	10 × 20	2,322	0.042	0.17
330	10 × 25	2,626	0.037	0.15
470	10 × 33	2,954	0.033	0.13

RIPPLE CURRENT MULTIPLIERS

Frequency Multipliers

Cap.(μF) \ Freq.(Hz)	120	1k	10k	50k	100k
100 ~ 270	0.50	0.73	0.92	0.95	1.00
330 ~ 680	0.55	0.77	0.94	0.96	1.00
820 ~ 1,800	0.60	0.80	0.96	0.97	1.00
2,200 ~ 2,700	0.70	0.85	0.98	0.99	1.00

NXH Series

• 105°C 6,000~10,000Hrs assured.

- Non-solvent proof.
- Low Impedance.
- Long Life.
- For LED TV BLU Inverter, SMPS, IP-Board, Adaptor.
- RoHS compliant.
- Halogen-free capacitors are also available.

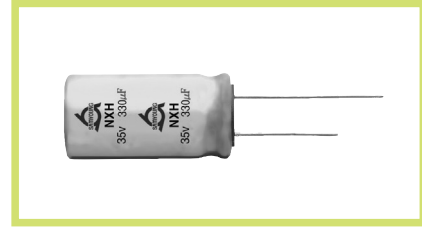

SPECIFICATIONS

Item	Characteristics																				
Rated Voltage Range	6.3 ~ 100 V _{DC}																				
Operating Temperature Range	-40 ~ +105°C																				
Capacitance Tolerance	±20%(M) (at 20°C, 120Hz)																				
Leakage Current	I = 0.01CV(μA) or 3μA, whichever is greater. Where, I:Max. Leakage current(μA), C:Nominal capacitance(μF), V:Rated voltage(V _{DC}) (at 20°C, 2 minutes)																				
Dissipation Factor(Tanδ)	<table border="1"> <tr> <td>Rated voltage(V_{DC})</td> <td>6.3</td> <td>10</td> <td>16</td> <td>25</td> <td>35</td> <td>50</td> <td>63</td> <td>80</td> <td>100</td> </tr> <tr> <td>Tanδ(Max.)</td> <td>0.22</td> <td>0.19</td> <td>0.16</td> <td>0.14</td> <td>0.12</td> <td>0.10</td> <td>0.09</td> <td>0.08</td> <td>0.08</td> </tr> </table> <p>When the capacitance exceeds 1,000μF, 0.02 shall be added every 1,000μF increase. (at 20°C, 120Hz)</p>	Rated voltage(V _{DC})	6.3	10	16	25	35	50	63	80	100	Tanδ(Max.)	0.22	0.19	0.16	0.14	0.12	0.10	0.09	0.08	0.08
Rated voltage(V _{DC})	6.3	10	16	25	35	50	63	80	100												
Tanδ(Max.)	0.22	0.19	0.16	0.14	0.12	0.10	0.09	0.08	0.08												
Temperature Characteristics (Max. Impedance ratio)	<table border="1"> <tr> <td>Z(-25°C)/Z(+20°C)</td> <td>2</td> </tr> <tr> <td>Z(-40°C)/Z(+20°C)</td> <td>3</td> </tr> </table> <p>(at 120Hz)</p>	Z(-25°C)/Z(+20°C)	2	Z(-40°C)/Z(+20°C)	3																
Z(-25°C)/Z(+20°C)	2																				
Z(-40°C)/Z(+20°C)	3																				
Load Life	<p>The following specifications shall be satisfied when the capacitors are restored to 20°C after the rated voltage with the rated ripple current is applied (the peak voltage shall not exceed the rated voltage) at 105°C for the specified period of time.</p> <table border="1"> <tr> <td>Rated voltage(V_{DC})</td> <td>6.3~10</td> <td>16~100</td> <td>∅D</td> <td>Life Time</td> </tr> <tr> <td>Capacitance change</td> <td>≤±30% of the initial value</td> <td>≤±25% of the initial value</td> <td>∅5~∅6.3</td> <td>6,000 hours</td> </tr> <tr> <td>Tan δ</td> <td colspan="2">≤200% of the initial specified value</td> <td>∅8</td> <td>8,000 hours</td> </tr> <tr> <td>Leakage current</td> <td colspan="2">≤The initial specified value</td> <td>∅10~</td> <td>10,000 hours</td> </tr> </table>	Rated voltage(V _{DC})	6.3~10	16~100	∅D	Life Time	Capacitance change	≤±30% of the initial value	≤±25% of the initial value	∅5~∅6.3	6,000 hours	Tan δ	≤200% of the initial specified value		∅8	8,000 hours	Leakage current	≤The initial specified value		∅10~	10,000 hours
Rated voltage(V _{DC})	6.3~10	16~100	∅D	Life Time																	
Capacitance change	≤±30% of the initial value	≤±25% of the initial value	∅5~∅6.3	6,000 hours																	
Tan δ	≤200% of the initial specified value		∅8	8,000 hours																	
Leakage current	≤The initial specified value		∅10~	10,000 hours																	
Shelf Life	<p>The following specifications shall be satisfied when the capacitors are restored to 20°C after exposing them for 1,000 hours at 105°C without voltage applied. The rated voltage shall be applied to the capacitors for a minimum of 30 minutes, at least 24 hours and not more than 48 hours before the measurements.</p> <table border="1"> <tr> <td>Rated voltage(V_{DC})</td> <td>6.3~10</td> <td>16~100</td> </tr> <tr> <td>Capacitance change</td> <td>≤±30% of the initial value</td> <td>≤±25% of the initial value</td> </tr> <tr> <td>Tan δ</td> <td colspan="2">≤200% of the initial specified value</td> </tr> <tr> <td>Leakage current</td> <td colspan="2">≤The initial specified value</td> </tr> </table>	Rated voltage(V _{DC})	6.3~10	16~100	Capacitance change	≤±30% of the initial value	≤±25% of the initial value	Tan δ	≤200% of the initial specified value		Leakage current	≤The initial specified value									
Rated voltage(V _{DC})	6.3~10	16~100																			
Capacitance change	≤±30% of the initial value	≤±25% of the initial value																			
Tan δ	≤200% of the initial specified value																				
Leakage current	≤The initial specified value																				
Others	Satisfied characteristics KS C IEC 60384-4																				

DIMENSIONS OF NXH Series

Unit(mm)

Marking : YELLOW SLEEVE, BLACK INK

∅D	5	6.3	8	10	12.5	16	18
∅d	0.5	0.5	0.6	0.6	0.6	0.8	0.8
F	2.0	2.5	3.5	5.0	5.0	7.5	7.5
∅D'	∅D + 0.5 max.						
L'	L + 1.5 max.			L + 2.0 max.			

※ ∅10 x 12L, L' ≤ L + 1.5

RATINGS OF NXH Series

∅D×L(mm)	V _{DC}	6.3			10			16					
		μF	IMP.		Ripple	μF	IMP.		Ripple	μF	IMP.		Ripple
			20°C	-10°C			20°C	-10°C			20°C	-10°C	
5 × 11		220	0.22	0.80	345	150	0.22	0.80	345	100	0.22	0.80	345
5 × 15		470	0.13	0.47	480	330	0.13	0.47	480	220	0.13	0.47	480
6.3 × 11		470	0.094	0.35	540	330	0.094	0.35	540	220	0.094	0.35	540
6.3 × 15		560	0.084	0.31	620	470	0.084	0.31	620	330	0.084	0.31	620
8 × 11.5		820	0.056	0.19	945	680	0.056	0.19	945	470	0.056	0.19	945
8 × 15		1,200	0.045	0.15	1,250	1,000	0.045	0.15	1,250	680	0.045	0.15	1,250
8 × 20		1,500	0.029	0.11	1,500	1,500	0.029	0.11	1,500	1,000	0.029	0.11	1,500
10 × 12		1,200	0.039	0.14	1,330	1,000	0.039	0.14	1,330	680	0.039	0.14	1,330
10 × 12.5		1,200	0.039	0.14	1,330	1,000	0.039	0.14	1,330	680	0.039	0.14	1,330
10 × 16		1,800	0.028	0.10	1,760	1,500	0.028	0.10	1,760	1,000	0.028	0.10	1,760
10 × 20		2,200	0.020	0.060	1,960	1,800	0.020	0.060	1,960	1,500	0.020	0.060	1,960
10 × 25		2,700	0.018	0.054	2,250	2,200	0.018	0.054	2,250	1,800	0.018	0.054	2,250
10 × 33		3,300	0.015	0.045	2,550	2,700	0.015	0.045	2,550	2,200	0.015	0.045	2,550
12.5 × 20		3,900	0.017	0.043	2,480	3,300	0.017	0.043	2,480	2,200	0.017	0.043	2,480
12.5 × 25		4,700	0.015	0.038	2,900	3,900	0.015	0.038	2,900	2,700	0.015	0.038	2,900
12.5 × 30		5,600	0.013	0.033	3,450	4,700	0.013	0.033	3,450	3,300	0.013	0.033	3,450
12.5 × 35		6,800	0.012	0.031	3,570	5,600	0.012	0.031	3,570	3,900	0.012	0.031	3,570
16 × 20		6,800	0.015	0.038	3,250	4,700	0.015	0.038	3,250	3,300	0.015	0.038	3,250
16 × 25		8,200	0.013	0.035	3,630	6,800	0.013	0.035	3,630	4,700	0.013	0.035	3,630
18 × 25		10,000	0.012	0.031	3,650	8,200	0.012	0.031	3,650	5,600	0.012	0.031	3,650

∅D×L(mm)	V _{DC}	25			35			50					
		μF	IMP.		Ripple	μF	IMP.		Ripple	μF	IMP.		Ripple
			20°C	-10°C			20°C	-10°C			20°C	-10°C	
5 × 11		68	0.22	0.80	345	47	0.22	0.80	345	2.2	2.5	8.68	120
										4.7	2.5	8.68	120
										10	1.0	3.47	145
										22	0.40	1.39	195
										27	0.34	1.18	238
5 × 15		150	0.13	0.47	480	100	0.13	0.47	480	56	0.16	0.56	350
										33	0.20	0.71	320
6.3 × 11		150	0.094	0.35	540	100	0.094	0.35	540	47	0.14	0.50	450
										56	0.14	0.50	450
										100	0.12	0.43	586
6.3 × 15		220	0.084	0.31	620	150	0.084	0.31	620	100	0.12	0.43	586
8 × 11.5		330	0.056	0.19	945	220	0.056	0.19	945	100	0.074	0.22	724
8 × 15		390	0.045	0.15	1,250	270	0.045	0.15	1,250	120	0.061	0.18	950
		470	0.045	0.15	1,330								
8 × 20		560	0.029	0.11	1,500	390	0.029	0.11	1,500	180	0.046	0.14	1,190
						470	0.029		1,600				
10 × 12		470	0.039	0.14	1,330	330	0.039	0.14	1,330	68	0.070	0.21	750
										150	0.061	0.18	979
10 × 12.5		470	0.039	0.14	1,330	330	0.039	0.14	1,330	68	0.070	0.21	750
										150	0.061	0.18	979
10 × 16		680	0.028	0.10	1,760	470	0.028	0.10	1,760	220	0.042	0.12	1,370
		820	0.020	0.060	1,960								
10 × 20		1,000	0.020	0.060	1,960	680	0.025	0.075	1,850	270	0.030	0.090	1,580
		1,000	0.018	0.054	2,250								
10 × 25		1,000	0.018	0.054	2,250	680	0.018	0.054	2,250	330	0.028	0.085	1,870
10 × 33		1,200	0.015	0.045	2,550	1,000	0.015	0.045	2,550	470	0.025	0.076	2,110
12.5 × 20		1,000	0.018	0.045	2,500	1,000	0.017	0.043	2,480	470	0.027	0.068	2,050
		1,500	0.017	0.043	2,550								
12.5 × 25		1,800	0.015	0.038	2,900	1,200	0.015	0.038	2,900	560	0.023	0.059	2,410
12.5 × 30		2,200	0.013	0.033	3,450	1,500	0.013	0.033	3,450	680	0.021	0.052	2,860
12.5 × 35		2,700	0.012	0.031	3,570	1,800	0.012	0.031	3,570	820	0.019	0.051	2,960
16 × 20		2,200	0.015	0.038	3,250	1,500	0.015	0.038	3,250	820	0.023	0.059	2,730
		2,700	0.015	0.038	3,250								
16 × 25		3,300	0.013	0.035	3,630	2,200	0.013	0.035	3,630	1,000	0.021	0.056	3,010
18 × 25		3,900	0.012	0.031	3,650	2,700	0.012	0.031	3,650	1,500	0.019	0.051	3,290

NXH Series

RATINGS OF NXH Series

V _{DC} ∅D×L(mm)	63			
	μF	IMP.		Ripple
		20°C	-10°C	
5×11	18	0.45	1.8	173
6.3×11	47	0.30	1.2	278
8×11.5	82	0.20	0.80	525
8×15	100	0.18	0.72	688
8×20	150	0.16	0.64	861
10×12	120	0.16	0.64	725
10×12.5	120	0.16	0.64	725
10×16	180	0.10	0.40	998
10×20	270	0.080	0.32	1,200
10×25	330	0.070	0.28	1,410
12.5×20	390	0.050	0.20	1,570
12.5×25	470	0.037	0.15	1,990
12.5×30	560	0.032	0.13	2,410
12.5×35	680	0.030	0.12	2,620
16×20	560	0.035	0.14	2,100
16×25	820	0.030	0.12	2,430

V _{DC} ∅D×L(mm)	80				100			
	μF	IMP.		Ripple	μF	IMP.		Ripple
		20°C	-10°C			20°C	-10°C	
5×11	12	1.2	5.33	163	8.2	1.2	5.33	163
6.3×11	33	0.46	2.03	267	18	0.46	2.03	267
8×11.5	56	0.29	1.31	462	33	0.29	1.31	462
8×15	68	0.20	0.90	585	47	0.20	0.90	585
8×20	100	0.16	0.72	735	68	0.16	0.72	735
10×12	82	0.17	0.68	624	47	0.17	0.68	624
10×12.5	82	0.17	0.68	624	47	0.17	0.68	624
10×16	120	0.11	0.44	780	68	0.11	0.44	780
10×20	180	0.084	0.35	1,040	100	0.084	0.35	1,040
10×25	220	0.069	0.28	1,170	120	0.069	0.28	1,170
12.5×16	180	0.11	0.33	975	100	0.11	0.33	975
12.5×20	270	0.062	0.19	1,430	150	0.062	0.19	1,430
12.5×25	330	0.047	0.15	1,620	220	0.047	0.15	1,620
12.5×30	390	0.042	0.14	1,950	270	0.042	0.14	1,950
12.5×35	470	0.036	0.11	2,140	330	0.036	0.11	2,140
12.5 x 40	560	0.032	0.096	2,340	390	0.032	0.096	2340
16×20	390	0.048	0.16	1,750	270	0.048	0.16	1,750
16×25	560	0.038	0.11	2,210	390	0.038	0.11	2,210
16×31.5	680	0.032	0.096	2,400	470	0.032	0.096	2,400
16×35.5	820	0.029	0.087	2,600	560	0.029	0.087	2,600
16×40	1,000	0.027	0.081	2,860	680	0.027	0.081	2,860
18×20	560	0.045	0.14	1,950	390	0.045	0.14	1,950
18×25	820	0.036	0.11	2,270	470	0.036	0.11	2,270
18×31.5	1,000	0.030	0.090	2,470	560	0.030	0.090	2,470
18×35.5	1,200	0.027	0.081	2,860	680	0.027	0.081	2,860
18×40	1,500	0.026	0.078	3,510	820	0.026	0.078	3,510

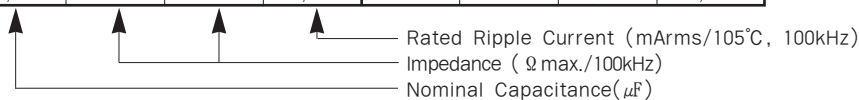

RIPPLE CURRENT MULTIPLIERS

Frequency Multipliers

Cap.(μF)	Freq.(Hz)	120	1k	10k	50k	100k
2.2 ~ 22		0.40	0.66	0.85	0.90	1.00
27 ~ 33		0.42	0.70	0.90	0.93	1.00
39 ~ 270		0.50	0.73	0.92	0.95	1.00
330 ~ 680		0.55	0.77	0.94	0.96	1.00
820 ~ 1,800		0.60	0.80	0.96	0.97	1.00
2,200 ~ 10,000		0.70	0.85	0.98	0.99	1.00

NXQ Series

• 105°C 6,000 ~ 10,000Hrs assured.

- Non-solvent proof.
- Low Impedance, High Ripple.
- For LED TV BLU Inverter, IP-Board, Adaptor, LED Lighting.
- RoHS compliant.
- Halogen-free capacitors are also available.

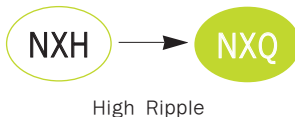

SPECIFICATIONS

Item	Characteristics																																											
Rated Voltage Range	6.3 ~ 120 V _{DC}																																											
Operating Temperature Range	-40 ~ +105°C																																											
Capacitance Tolerance	±20%(M) (at 20°C, 120Hz)																																											
Leakage Current	I = 0.01CV(μA) or 3μA, whichever is greater. Where, I:Max. Leakage current(μA), C:Nominal capacitance(μF), V:Rated voltage(V _{DC}) (at 20°C, 2minutes)																																											
Dissipation Factor (Tanδ)	<table border="1"> <tr> <th>Rated Voltage(V_{DC})</th> <td>6.3</td> <td>10</td> <td>16</td> <td>25</td> <td>35</td> <td>50</td> <td>63</td> <td>80</td> <td>100</td> <td>120</td> </tr> <tr> <th>Tanδ(Max.)</th> <td>0.22</td> <td>0.19</td> <td>0.16</td> <td>0.14</td> <td>0.12</td> <td>0.10</td> <td>0.09</td> <td>0.08</td> <td>0.08</td> <td>0.08</td> </tr> </table> <p>When the capacitance exceeds 1,000μF, 0.02 shall be added every 1,000μF increase (at 20°C, 120Hz)</p>	Rated Voltage(V _{DC})	6.3	10	16	25	35	50	63	80	100	120	Tanδ(Max.)	0.22	0.19	0.16	0.14	0.12	0.10	0.09	0.08	0.08	0.08																					
Rated Voltage(V _{DC})	6.3	10	16	25	35	50	63	80	100	120																																		
Tanδ(Max.)	0.22	0.19	0.16	0.14	0.12	0.10	0.09	0.08	0.08	0.08																																		
Temperature Characteristics (Max. Impedance ratio)	<table border="1"> <tr> <td>Z(-25°C)/Z(+20°C)</td> <td>2</td> </tr> <tr> <td>Z(-40°C)/Z(+20°C)</td> <td>3</td> </tr> </table> <p>(at 120Hz)</p>	Z(-25°C)/Z(+20°C)	2	Z(-40°C)/Z(+20°C)	3																																							
Z(-25°C)/Z(+20°C)	2																																											
Z(-40°C)/Z(+20°C)	3																																											
Load Life	<p>The following specifications shall be satisfied when the capacitors are restored to 20°C after the rated voltage with the rated ripple current is applied (the peak voltage shall not exceed the rated voltage) at 105°C for the specified period of time.</p> <table border="1"> <tr> <th>Rated voltage(V_{DC})</th> <td>6.3~10</td> <td>16~120</td> </tr> <tr> <th>Capacitance change</th> <td>≤ ±30% of the initial value</td> <td>≤ ±25% of the initial value</td> </tr> <tr> <th>Tanδ</th> <td colspan="2">≤ 200% of the initial specified value</td> </tr> <tr> <th>Leakage current</th> <td colspan="2">≤ The initial specified value</td> </tr> </table> <table border="1"> <tr> <th rowspan="2">Case Size(φD)</th> <th colspan="3">Life Time</th> </tr> <tr> <th>6.3V_{DC}</th> <th>10~50V_{DC}</th> <th>63~120V_{DC}</th> </tr> <tr> <td>φ5~φ6.3</td> <td>6,000hours</td> <td>7,000hours</td> <td>6,000hours</td> </tr> <tr> <td>φ6 X 11.5L</td> <td>8,000hours</td> <td>9,000hours</td> <td>8,000hours</td> </tr> <tr> <td>φ8 X 15L~20L</td> <td>9,000hours</td> <td>10,000hours</td> <td>9,000hours</td> </tr> <tr> <td>φ10 X 10~12.5L</td> <td colspan="3">9,000hours</td> </tr> <tr> <td>φ10 X 16L~25L</td> <td colspan="3">10,000hours</td> </tr> <tr> <td>φ12.5~</td> <td colspan="3">10,000hours</td> </tr> </table>	Rated voltage(V _{DC})	6.3~10	16~120	Capacitance change	≤ ±30% of the initial value	≤ ±25% of the initial value	Tanδ	≤ 200% of the initial specified value		Leakage current	≤ The initial specified value		Case Size(φD)	Life Time			6.3V _{DC}	10~50V _{DC}	63~120V _{DC}	φ5~φ6.3	6,000hours	7,000hours	6,000hours	φ6 X 11.5L	8,000hours	9,000hours	8,000hours	φ8 X 15L~20L	9,000hours	10,000hours	9,000hours	φ10 X 10~12.5L	9,000hours			φ10 X 16L~25L	10,000hours			φ12.5~	10,000hours		
Rated voltage(V _{DC})	6.3~10	16~120																																										
Capacitance change	≤ ±30% of the initial value	≤ ±25% of the initial value																																										
Tanδ	≤ 200% of the initial specified value																																											
Leakage current	≤ The initial specified value																																											
Case Size(φD)	Life Time																																											
	6.3V _{DC}	10~50V _{DC}	63~120V _{DC}																																									
φ5~φ6.3	6,000hours	7,000hours	6,000hours																																									
φ6 X 11.5L	8,000hours	9,000hours	8,000hours																																									
φ8 X 15L~20L	9,000hours	10,000hours	9,000hours																																									
φ10 X 10~12.5L	9,000hours																																											
φ10 X 16L~25L	10,000hours																																											
φ12.5~	10,000hours																																											
Shelf Life	<p>The following specifications shall be satisfied when the capacitors are restored to 20°C after exposing them for 500 hours at 105°C without voltage applied. The rated voltage shall be applied to the capacitors for a minimum of 30 minutes, at least 24 hours and not more than 48 hours before the measurements.</p> <table border="1"> <tr> <th>Rated voltage(V_{DC})</th> <td>6.3~10</td> <td>16~120</td> </tr> <tr> <th>Capacitance change</th> <td>≤ ±30% of the initial value</td> <td>≤ ±25% of the initial value</td> </tr> <tr> <th>Tanδ</th> <td colspan="2">≤ 200% of the initial specified value</td> </tr> <tr> <th>Leakage current</th> <td colspan="2">≤ The initial specified value</td> </tr> </table>	Rated voltage(V _{DC})	6.3~10	16~120	Capacitance change	≤ ±30% of the initial value	≤ ±25% of the initial value	Tanδ	≤ 200% of the initial specified value		Leakage current	≤ The initial specified value																																
Rated voltage(V _{DC})	6.3~10	16~120																																										
Capacitance change	≤ ±30% of the initial value	≤ ±25% of the initial value																																										
Tanδ	≤ 200% of the initial specified value																																											
Leakage current	≤ The initial specified value																																											
Others	Satisfied characteristics KS C IEC 60384-4																																											

DIMENSIONS OF NXQ Series

Unit(mm)

Marking : DARK BROWN SLEEVE, SILVER INK

φD	5	6.3	8	10	12.5	16	18
φd	0.5	0.5	0.6	0.6	0.6	0.8	0.8
F	2.0	2.5	3.5	5.0	5.0	7.5	7.5
φD'	φD + 0.5 max.						
L'	L + 1.5 max.			L + 2.0 max.			

※ φ10 x 12L, L' ≤ L + 1.5

RATINGS OF NXQ Series

V _{DC} ∅D×L(mm)	6.3				10				16			
	μF	IMP.		Ripple	μF	IMP.		Ripple	μF	IMP.		Ripple
		20°C	-10°C			20°C	-10°C			20°C	-10°C	
5 × 11	220	0.40	1.30	345	150	0.40	1.30	450	120	0.40	1.30	450
6.3 × 11	470	0.17	0.51	540	330	0.17	0.51	700	270	0.17	0.51	700
8 × 11.5	820	0.075	0.23	945	560	0.075	0.23	1,200	470	0.075	0.23	1,200
8 × 15	1,000	0.059	0.18	1,250	680	0.059	0.18	1,600	560	0.059	0.18	1,600
8 × 20	1,500	0.041	0.13	1,500	1,000	0.041	0.13	1,960	820	0.041	0.13	1,960
10 × 12	1,200	0.053	0.16	1,500	820	0.053	0.16	1,700	680	0.053	0.16	1,700
10 × 12.5	1,200	0.053	0.16	1,500	820	0.053	0.16	1,700	680	0.053	0.16	1,700
10 × 16	1,800	0.038	0.12	1,760	1,200	0.038	0.12	2,000	1,000	0.038	0.12	2,000
10 × 20	2,700	0.028	0.084	1,960	1,800	0.028	0.084	2,500	1,500	0.028	0.084	2,500
10 × 25	3,300	0.024	0.072	2,250	2,200	0.024	0.072	2,900	1,800	0.024	0.072	2,900
12.5 × 20	3,900	0.025	0.075	2,480	2,700	0.025	0.075	2,600	2,200	0.025	0.075	2,600
12.5 × 25	4,700	0.019	0.057	2,900	3,300	0.019	0.057	3,050	2,700	0.019	0.057	3,050
12.5 × 30	5,600	0.018	0.054	3,450	4,700	0.018	0.054	3,500	3,300	0.018	0.054	3,500
12.5 × 35	6,800	0.016	0.048	3,570	5,600	0.016	0.048	3,600	3,900	0.016	0.048	3,600
16 × 20	6,800	0.021	0.063	3,250	4,700	0.021	0.063	3,250	3,300	0.021	0.063	3,250
16 × 25	8,200	0.017	0.051	3,630	5,600	0.017	0.051	3,630	4,700	0.017	0.051	3,630

V _{DC} ∅D×L(mm)	25				35				50			
	μF	IMP.		Ripple	μF	IMP.		Ripple	μF	IMP.		Ripple
		20°C	-10°C			20°C	-10°C			20°C	-10°C	
5 × 11	68	0.40	1.30	450	47	0.40	1.30	450	27	0.48	1.56	310
6.3 × 11	150	0.17	0.51	700	100	0.17	0.51	700	56	0.22	0.66	500
8 × 11.5	330	0.075	0.23	1,200	180	0.075	0.23	1,200	100	0.12	0.37	950
8 × 15	390	0.059	0.18	1,600	220	0.059	0.18	1,600	120	0.082	0.25	1,230
8 × 20	560	0.041	0.13	1,960	330	0.041	0.13	1,960	180	0.058	0.19	1,580
10 × 10	390	0.063	0.20	1,500	270	0.063	0.20	1,500				
10 × 12	470	0.053	0.16	1,700	270	0.053	0.16	1,700	150	0.073	0.22	1,280
10 × 12.5	470	0.053	0.16	1,700	270	0.053	0.16	1,700	150	0.073	0.22	1,280
10 × 16	680	0.038	0.12	2,000	390	0.038	0.12	2,000	220	0.053	0.16	1,650
10 × 20	1,000	0.028	0.084	2,500	560	0.028	0.084	2,500	330	0.038	0.12	2,060
10 × 25	1,200	0.024	0.072	2,900	680	0.024	0.072	2,900	390	0.032	0.10	2,240
12.5 × 20	1,500	0.025	0.075	2,600	820	0.025	0.075	2,600	470	0.032	0.10	2,200
12.5 × 25	1,800	0.019	0.057	3,050	1,200	0.019	0.057	3,050	680	0.025	0.080	2,500
12.5 × 30	2,200	0.018	0.054	3,500	1,500	0.018	0.054	3,500	820	0.023	0.074	3,100
12.5 × 35	2,700	0.016	0.048	3,600	1,800	0.016	0.048	3,600	1,000	0.021	0.067	3,250
16 × 20	2,200	0.021	0.063	3,250	1,500	0.021	0.063	3,250	820	0.026	0.084	2,730
16 × 25	3,300	0.017	0.051	3,630	1,800	0.017	0.051	3,630	1,000	0.022	0.070	3,010

V _{DC} ∅D×L(mm)	63			
	μF	IMP.		Ripple
		20°C	-10°C	
5 × 11	18	0.71	3.10	240
6.3 × 11	47	0.28	1.30	420
8 × 11.5	82	0.18	0.82	720
8 × 15	100	0.13	0.59	990
8 × 20	150	0.096	0.44	1,200
10 × 12	120	0.11	0.44	990
10 × 12.5	120	0.11	0.44	990
10 × 16	180	0.076	0.31	1,200
10 × 20	270	0.056	0.22	1,570
10 × 25	330	0.046	0.15	1,990
12.5 × 20	390	0.041	0.12	1,990
12.5 × 25	470	0.031	0.095	2,460
12.5 × 30	560	0.028	0.088	2,760
12.5 × 35	680	0.024	0.074	3,040
16 × 20	560	0.032	0.101	2,150
16 × 25	820	0.025	0.075	2,550

RATINGS OF NXQ Series

V _{DC} #DxL(mm)	80				100				120			
	μF	IMP.		Ripple	μF	IMP.		Ripple	μF	IMP.		Ripple
		20°C	-10°C			20°C	-10°C			20°C	-10°C	
5 × 11	12	1.20	5.33	220	8.2	1.20	5.33	220				
6.3 × 11	27	0.46	2.03	370	18	0.46	2.03	370				
8 × 11.5	47	0.29	1.31	620	33	0.29	1.31	620	22	0.29	1.31	620
8 × 15	56	0.20	0.90	780	47	0.20	0.90	780	33	0.20	0.90	780
8 × 20	82	0.16	0.72	1,040	68	0.16	0.72	1,040	47	0.16	0.72	1,040
10 × 10					39	0.26	1.17	680				
10 × 12	68	0.17	0.68	780	47	0.17	0.68	780	33	0.17	0.68	780
10 × 12.5	68	0.17	0.68	780	56	0.17	0.68	780				
10 × 16	100	0.11	0.44	1,040	47	0.17	0.68	780	33	0.17	0.68	780
10 × 20	150	0.084	0.35	1,430	68	0.11	0.44	1,040	47	0.11	0.44	1,040
10 × 25	180	0.069	0.28	1,620	100	0.084	0.35	1,430	68	0.084	0.35	1,430
12.5 × 16	150	0.11	0.33	1,430	120	0.069	0.28	1,620	100	0.069	0.28	1,620
12.5 × 20	220	0.062	0.19	1,750	100	0.11	0.33	1,430	68	0.11	0.33	1,430
12.5 × 25	270	0.047	0.15	2,210	150	0.062	0.19	1,750	100	0.062	0.19	1,750
12.5 × 30	330	0.042	0.14	2,400	220	0.047	0.15	2,210	120	0.047	0.15	2,210
12.5 × 35	390	0.036	0.11	2,600	270	0.042	0.14	2,400	150	0.042	0.14	2,400
12.5 × 40	470	0.032	0.096	2,860	330	0.036	0.11	2,600	180	0.036	0.11	2,600
16 × 20	330	0.048	0.16	1,950	390	0.032	0.096	2,860	220	0.032	0.096	2,860
16 × 25	470	0.038	0.11	2,430	270	0.048	0.16	1,950	150	0.048	0.16	1,950
16 × 31.5	560	0.032	0.096	2,640	390	0.038	0.11	2,430	220	0.038	0.11	2,430
16 × 35.5	680	0.029	0.087	2,860	470	0.032	0.096	2,640	270	0.032	0.096	2,640
16 × 40	820	0.027	0.081	3,510	560	0.029	0.087	2,860	330	0.029	0.087	2,860
18 × 20	470	0.045	0.14	2,270	680	0.027	0.081	3,510	390	0.027	0.081	3,510
18 × 25	680	0.036	0.11	2,500	390	0.045	0.14	2,270	220	0.045	0.14	2,270
18 × 31.5	820	0.030	0.090	2,860	470	0.036	0.11	2,500	270	0.036	0.11	2,500
18 × 35.5	1,000	0.027	0.081	3,510	560	0.030	0.090	2,860	390	0.030	0.090	2,860
18 × 40	1,200	0.026	0.078	3,860	680	0.027	0.081	3,510	470	0.027	0.081	3,510
					820	0.026	0.078	3,860	560	0.026	0.078	3,860

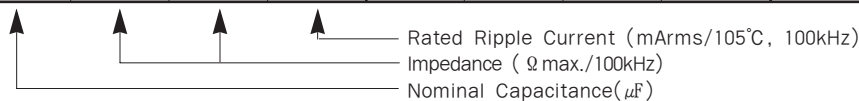

RATED RIPPLE CURRENT MULTIPLIERS

Frequency Multipliers

Cap.(μF) \ Freq.(Hz)	120	1k	10k	50k	100k
8.2 ~ 33	0.42	0.70	0.90	0.93	1.00
47 ~ 270	0.50	0.73	0.92	0.95	1.00
330 ~ 680	0.55	0.77	0.94	0.96	1.00
820 ~ 1,800	0.60	0.80	0.96	0.97	1.00
2,200 ~ 8,200	0.70	0.85	0.98	0.99	1.00

NXW Series

• 105°C 6,000~10,000Hrs assured.

- Non-solvent proof.
- Low Impedance, High ripple
- For LED TV BLU Inverter, IP-Board, Adaptor, LED Lighting
- RoHS compliant.
- Halogen-free capacitors are also available.

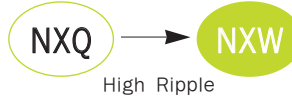

SPECIFICATIONS

Item	Characteristics														
Rated Voltage Range	6.3 ~ 50 V _{DC}														
Operating Temperature Range	-40 ~ +105°C														
Capacitance Tolerance	±20% (M) (at 20°C, 120Hz)														
Leakage Current	I = 0.01CV(µA) or 3µA, whichever is greater. Where, I : Max. Leakage current(µA), C : Nominal capacitance(µF), V : Rated voltage(V _{DC}) (at 20°C, 2minutes)														
Dissipation Factor(Tanδ)	<table border="1"> <tr> <td>Rated voltage(V_{DC})</td> <td>6.3</td> <td>10</td> <td>16</td> <td>25</td> <td>35</td> <td>50</td> </tr> <tr> <td>Tanδ(Max.)</td> <td>0.22</td> <td>0.19</td> <td>0.16</td> <td>0.14</td> <td>0.12</td> <td>0.10</td> </tr> </table> <p>Where the capacitance exceeds 1,000µF, 0.02 shall be added every 1,000µF increase (at 20°C, 120Hz)</p>	Rated voltage(V _{DC})	6.3	10	16	25	35	50	Tanδ(Max.)	0.22	0.19	0.16	0.14	0.12	0.10
Rated voltage(V _{DC})	6.3	10	16	25	35	50									
Tanδ(Max.)	0.22	0.19	0.16	0.14	0.12	0.10									
Temperature Characteristics (Max. Impedance ratio)	<table border="1"> <tr> <td>Z(-25°C)/Z(+20°C)</td> <td>2</td> </tr> <tr> <td>Z(-40°C)/Z(+20°C)</td> <td>3</td> </tr> </table> <p>(at 120Hz)</p>	Z(-25°C)/Z(+20°C)	2	Z(-40°C)/Z(+20°C)	3										
Z(-25°C)/Z(+20°C)	2														
Z(-40°C)/Z(+20°C)	3														
Load Life	<p>The following specifications shall be satisfied when the capacitors are restored to 20°C after the rated voltage with the rated ripple current is applied (the peak voltage shall not exceed the rated voltage) at 105°C for the specified period of time.</p> <table border="1"> <thead> <tr> <th>Case Size</th> <th>Life Time</th> </tr> </thead> <tbody> <tr> <td>φ5~φ6.3</td> <td>6,000hours</td> </tr> <tr> <td>φ8</td> <td>8,000hours</td> </tr> <tr> <td>φ10 X 12L~12.5L</td> <td>9,000hours</td> </tr> <tr> <td>φ10 X 16L~25L φ12.5~</td> <td>10,000hours</td> </tr> </tbody> </table> <p>Capacitance change ≤ ±30 % of the initial value tan δ ≤ 200 % of the initial specified value Leakage current ≤ The initial specified value</p>	Case Size	Life Time	φ5~φ6.3	6,000hours	φ8	8,000hours	φ10 X 12L~12.5L	9,000hours	φ10 X 16L~25L φ12.5~	10,000hours				
Case Size	Life Time														
φ5~φ6.3	6,000hours														
φ8	8,000hours														
φ10 X 12L~12.5L	9,000hours														
φ10 X 16L~25L φ12.5~	10,000hours														
Shelf Life	<p>The following specifications shall be satisfied when the capacitors are restored to 20°C after exposing them for 500 hours at 105°C without voltage applied. The rated voltage shall be applied to the capacitors for a minimum of 30 minutes, at least 24 hours and not more than 48 hours before the measurements.</p> <p>Capacitance change ≤ ±30 % of the initial value tan δ ≤ 200 % of the initial specified value Leakage current ≤ The initial specified value</p>														
Others	Satisfied characteristics KS C IEC 60384-4														

DIMENSIONS OF NXW Series

Unit(mm)

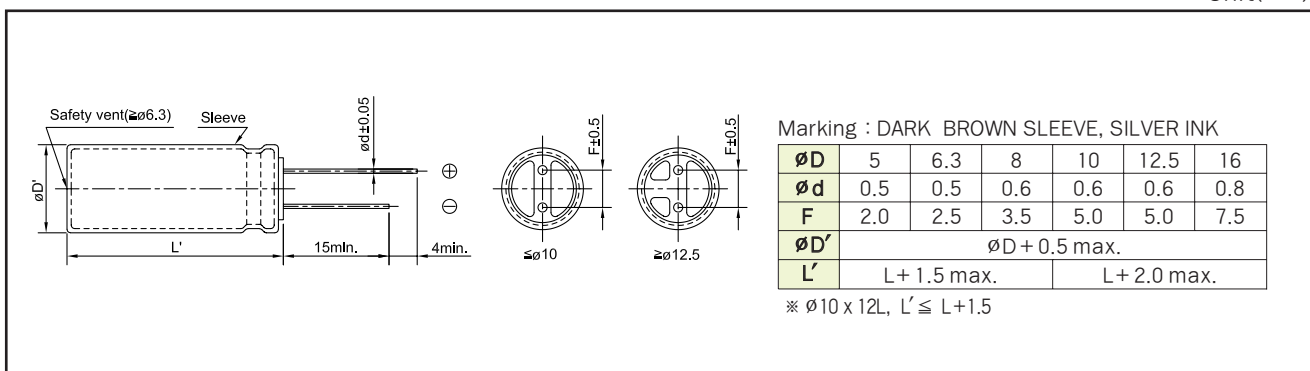

RATINGS OF NXW Series

∅D×L(mm)	V _{DC}	6.3			10			16					
		μF	IMP.		Ripple	μF	IMP.		Ripple	μF	IMP.		Ripple
			20°C	-10°C			20°C	-10°C			20°C	-10°C	
5 × 11		220	0.34	1.11	380	150	0.34	1.11	495	120	0.34	1.11	495
6.3 × 11		470	0.14	0.47	594	330	0.14	0.47	770	270	0.14	0.47	770
8 × 11.5		820	0.064	0.21	1,040	560	0.064	0.21	1,320	470	0.064	0.21	1,320
8 × 15		1,000	0.050	0.16	1,375	680	0.050	0.16	1,760	560	0.050	0.16	1,760
8 × 20		1,500	0.035	0.11	1,650	1,000	0.035	0.11	2,156	820	0.035	0.11	2,156
10 × 12		1,200	0.045	0.14	1,620	820	0.045	0.14	1,836	680	0.045	0.14	1,836
10 × 12.5		1,200	0.045	0.14	1,620	820	0.045	0.14	1,836	680	0.045	0.14	1,836
10 × 16		1,800	0.032	0.10	1,901	1,200	0.032	0.10	2,160	1,000	0.032	0.10	2,160
10 × 20		2,700	0.024	0.074	2,117	1,800	0.024	0.074	2,700	1,500	0.024	0.074	2,700
10 × 25		3,300	0.020	0.063	2,430	2,200	0.020	0.063	3,132	1,800	0.020	0.063	3,132
12.5 × 20		3,900	0.021	0.066	2,678	2,700	0.021	0.066	2,808	2,200	0.021	0.066	2,808
12.5 × 25		4,700	0.016	0.050	3,132	3,300	0.016	0.050	3,294	2,700	0.016	0.050	3,294
12.5 × 30		5,600	0.015	0.047	3,726	4,700	0.015	0.047	3,780	3,300	0.015	0.047	3,780
12.5 × 35		6,800	0.014	0.042	3,856	5,600	0.014	0.042	3,888	3,900	0.014	0.042	3,888
16 × 20		6,800	0.018	0.055	3,413	4,700	0.018	0.055	3,413	3,300	0.018	0.055	3,413
16 × 25		8,200	0.014	0.045	3,812	5,600	0.014	0.045	3,812	4,700	0.014	0.045	3,812

∅D×L(mm)	V _{DC}	25			35			50					
		μF	IMP.		Ripple	μF	IMP.		Ripple	μF	IMP.		Ripple
			20°C	-10°C			20°C	-10°C			20°C	-10°C	
5 × 11		68	0.34	1.11	495	47	0.34	1.11	495	27	0.43	1.39	341
6.3 × 11		150	0.14	0.47	770	100	0.14	0.47	770	56	0.20	0.64	550
8 × 11.5		330	0.064	0.21	1,320	180	0.064	0.21	1,320	100	0.11	0.36	1,045
8 × 15		390	0.050	0.16	1,760	220	0.050	0.16	1,760	120	0.074	0.24	1,353
8 × 20		560	0.035	0.11	2,156	330	0.035	0.11	2,156	180	0.053	0.17	1,738
10 × 12		470	0.045	0.14	1,836	270	0.045	0.14	1,836	150	0.062	0.19	1,382
10 × 12.5		470	0.045	0.14	1,836	270	0.045	0.14	1,836	150	0.062	0.19	1,382
10 × 16		680	0.032	0.10	2,160	390	0.032	0.10	2,160	220	0.045	0.14	1,782
10 × 20		1,000	0.024	0.074	2,700	560	0.024	0.074	2,700	330	0.032	0.10	2,305
10 × 25		1,200	0.020	0.063	3,132	680	0.020	0.063	3,132	390	0.027	0.08	2,419
12.5 × 20		1,500	0.021	0.066	2,808	820	0.021	0.066	2,808	470	0.027	0.08	2,376
12.5 × 25		1,800	0.016	0.050	3,294	1,200	0.016	0.050	3,294	680	0.021	0.066	2,700
12.5 × 30		2,200	0.015	0.047	3,780	1,500	0.015	0.047	3,780	820	0.020	0.061	3,348
12.5 × 35		2,700	0.014	0.042	3,888	1,800	0.014	0.042	3,888	1,000	0.018	0.055	3,510
16 × 20		2,200	0.018	0.055	3,413	1,500	0.018	0.055	3,413	820	0.022	0.069	2,867
16 × 25		3,300	0.014	0.045	3,812	1,800	0.014	0.045	3,812	1,000	0.019	0.058	3,161



RATED RIPPLE CURRENT MULTIPLIERS

Frequency Multipliers

Cap.(μF)	Freq.(Hz)				
	120	1k	10k	50k	100k
27 ~ 33	0.42	0.70	0.90	0.93	1.00
47 ~ 270	0.50	0.73	0.92	0.95	1.00
330 ~ 680	0.55	0.77	0.94	0.96	1.00
820 ~ 1,800	0.60	0.80	0.96	0.97	1.00
2,200 ~ 8,200	0.70	0.85	0.98	0.99	1.00

NXE Series

• 105°C 3,000~4,000Hrs assured.

- Non-solvent proof.
- Ultra Low ESR, Long Life.
- For MAIN-Board, SMPS.
- RoHS compliant.
- Halogen-free capacitors are also available.



SPECIFICATIONS

Item	Characteristics												
Rated Voltage Range	6.3 ~ 35 V _{DC}												
Operating Temperature Range	-40 ~ + 105°C												
Capacitance Tolerance	±20% (M) (at 20°C, 120Hz)												
Leakage Current	I = 0.03CV(μA) or 4μA, whichever is greater. Where, I:Max. Leakage current(μA), C:Nominal capacitance(μF), V:Rated voltage(V _{DC}) (at 20°C, 2 minutes)												
Dissipation Factor(Tanδ)	<table border="1"> <tr> <td>Rated Voltage(V_{DC})</td> <td>6.3</td> <td>10</td> <td>16</td> <td>25</td> <td>35</td> </tr> <tr> <td>Tanδ(Max.)</td> <td>0.22</td> <td>0.19</td> <td>0.16</td> <td>0.14</td> <td>0.12</td> </tr> </table> (at 20°C, 120Hz)	Rated Voltage(V _{DC})	6.3	10	16	25	35	Tanδ(Max.)	0.22	0.19	0.16	0.14	0.12
Rated Voltage(V _{DC})	6.3	10	16	25	35								
Tanδ(Max.)	0.22	0.19	0.16	0.14	0.12								
Temperature Characteristics (Max. Impedance ratio)	<table border="1"> <tr> <td>Z(-25°C) / Z(20°C)</td> <td>2</td> </tr> <tr> <td>Z(-40°C) / Z(20°C)</td> <td>3</td> </tr> </table> (at 120Hz)	Z(-25°C) / Z(20°C)	2	Z(-40°C) / Z(20°C)	3								
Z(-25°C) / Z(20°C)	2												
Z(-40°C) / Z(20°C)	3												
Load Life	<p>The following specifications shall be satisfied when the capacitors are restored to 20°C after the rated voltage with the rated ripple current is applied (the peak voltage shall not exceed the rated voltage) at 105°C for the specified period of time.</p> <table border="1"> <tr> <td>Capacitance change</td> <td>≤ ±25% of the initial value</td> </tr> <tr> <td>Tanδ</td> <td>≤ 200% of the initial specified value</td> </tr> <tr> <td>Leakage current</td> <td>≤ The initial specified value</td> </tr> </table> <table border="1"> <tr> <td>∅D</td> <td>Life Time</td> </tr> <tr> <td>∅8</td> <td>3,000 hours</td> </tr> <tr> <td>∅10~</td> <td>4,000 hours</td> </tr> </table>	Capacitance change	≤ ±25% of the initial value	Tanδ	≤ 200% of the initial specified value	Leakage current	≤ The initial specified value	∅D	Life Time	∅8	3,000 hours	∅10~	4,000 hours
Capacitance change	≤ ±25% of the initial value												
Tanδ	≤ 200% of the initial specified value												
Leakage current	≤ The initial specified value												
∅D	Life Time												
∅8	3,000 hours												
∅10~	4,000 hours												
Shelf Life	<p>The following specifications shall be satisfied when the capacitors are restored to 20°C after exposing them for 1,000 hours at 105°C without voltage applied. The rated voltage shall be applied to the capacitors for a minimum of 30 minutes, at least 24 hours and not more than 48 hours before the measurements.</p> <p>Capacitance change ≤ ±25% of the initial value Tanδ ≤ 200% of the initial specified value Leakage current ≤ 200% of the initial specified value</p>												
Others	Satisfied characteristics KS C IEC 60384-4												

DIMENSIONS OF NXE Series

Unit(mm)

Marking : DARK BROWN SLEEVE, SILVER INK

∅D	8	10	12.5
∅d	0.6	0.6	0.6
F	3.5	5.0	5.0
∅D'	∅D + 0.5 max.		
L'	L + 1.5 max.	L + 2.0 max.	

※ ∅10 x 12L, L' ≤ L + 1.5

RATINGS OF NXE series

Vdc		6.3			
μF	Items	ø D × L (mm)	Rated Ripple Current (mArms/105°C, 100kHz)	ESR	
				(Ω max./20°C, 100kHz)	(Ω max./-10°C, 100kHz)
820		8 × 11.5	1,140	0.036	0.11
1,200		8 × 15	1,490	0.028	0.085
1,800		8 × 20	1,870	0.019	0.057
1,500		10 × 12	1,540	0.030	0.091
1,500		10 × 12.5	1,540	0.030	0.091
1,800		10 × 16	2,000	0.019	0.057
2,200		10 × 20	2,550	0.013	0.039
3,300		10 × 25	2,800	0.012	0.036

Vdc		10			
μF	Items	ø D × L (mm)	Rated Ripple Current (mArms/105°C, 100kHz)	ESR	
				(Ω max./20°C, 100kHz)	(Ω max./-10°C, 100kHz)
680		8 × 11.5	1,140	0.036	0.11
1,000		8 × 15	1,490	0.028	0.085
1,500		8 × 20	1,870	0.019	0.057
1,000		10 × 12	1,540	0.030	0.091
1,000		10 × 12.5	1,540	0.030	0.091
1,200		10 × 16	2,000	0.019	0.057
1,500		10 × 16	2,000	0.019	0.057
1,800		10 × 20	2,550	0.013	0.039
2,200		10 × 25	2,800	0.012	0.036

Vdc		16			
μF	Items	ø D × L (mm)	Rated Ripple Current (mArms/105°C, 100kHz)	ESR	
				(Ω max./20°C, 100kHz)	(Ω max./-10°C, 100kHz)
470		8 × 11.5	1,140	0.036	0.11
680		8 × 15	1,490	0.028	0.085
1,000		8 × 20	1,870	0.019	0.057
680		10 × 12	1,540	0.030	0.091
680		10 × 12.5	1,540	0.030	0.091
1,000		10 × 16	2,000	0.019	0.057
1,500		10 × 20	2,550	0.013	0.039
1,800		10 × 25	2,800	0.012	0.036

Vdc		25			
μF	Items	ø D × L (mm)	Rated Ripple Current (mArms/105°C, 100kHz)	ESR	
				(Ω max./20°C, 100kHz)	(Ω max./-10°C, 100kHz)
220		8 × 11.5	1,140	0.036	0.11
390		8 × 15	1,490	0.028	0.085
560		8 × 20	1,870	0.019	0.057
470		10 × 12	1,540	0.030	0.091
470		10 × 12.5	1,540	0.030	0.091
680		10 × 16	2,000	0.019	0.057
820		10 × 20	2,550	0.013	0.039
1,000		10 × 25	2,800	0.012	0.036
1,200		12.5 × 20	3,000	0.014	0.042

Vdc		35			
μF	Items	ø D × L (mm)	Rated Ripple Current (mArms/105°C, 100kHz)	ESR	
				(Ω max./20°C, 100kHz)	(Ω max./-10°C, 100kHz)
150		8 × 11.5	1,140	0.036	0.11
270		8 × 15	1,490	0.028	0.085
390		8 × 20	1,870	0.019	0.057
330		10 × 12	1,540	0.030	0.091
330		10 × 12.5	1,540	0.030	0.091
470		10 × 16	2,000	0.019	0.057
560		10 × 20	2,550	0.013	0.039
680		10 × 25	2,800	0.012	0.036

RATED RIPPLE CURRENT MULTIPLIERS

Frequency Multipliers

Cap.(μF)	Freq.(Hz)	120	1k	10k	50k	100k
150 ~ 560		0.50	0.85	0.94	0.96	1.00
680 ~ 1,800		0.60	0.87	0.95	0.97	1.00
2,200 ~ 3,300		0.75	0.90	0.95	0.97	1.00

NXG Series

• 105°C 3,000~4,000Hrs assured.

- Non-solvent proof.
- Ultra Low Impedance/ESR, High Ripple, Long Life.
- For LED TV BLU Inverter, SMPS, IP-Board, Adaptor.
- RoHS compliant.
- Halogen-free capacitors are also available.

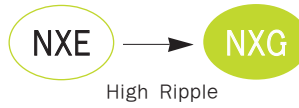

SPECIFICATIONS

Item	Characteristics												
Rated Voltage Range	6.3 ~ 35 V _{DC}												
Operating Temperature Range	-40 ~ + 105°C												
Capacitance Tolerance	±20% (M) (at 20°C, 120Hz)												
Leakage Current	I = 0.03CV(μA) or 4μA, Whichever is greater. Where, I:Max. Leakage current(μA), C:Nominal capacitance(μF), V:Rated voltage(V _{DC}) (at 20°C, 2 minutes)												
Dissipation Factor(Tanδ)	<table border="1"> <tr> <td>Rated Voltage(V_{DC})</td> <td>6.3</td> <td>10</td> <td>16</td> <td>25</td> <td>35</td> </tr> <tr> <td>Tanδ(Max.)</td> <td>0.22</td> <td>0.19</td> <td>0.16</td> <td>0.14</td> <td>0.12</td> </tr> </table> <p>When the capacitance exceeds 1,000μF, 0.02 shall be added every 1,000μF increase. (at 20°C, 120Hz)</p>	Rated Voltage(V _{DC})	6.3	10	16	25	35	Tanδ(Max.)	0.22	0.19	0.16	0.14	0.12
Rated Voltage(V _{DC})	6.3	10	16	25	35								
Tanδ(Max.)	0.22	0.19	0.16	0.14	0.12								
Temperature Characteristics (Max. Impedance ratio)	<table border="1"> <tr> <td>Z(-25°C) / Z(+20°C)</td> <td>2</td> </tr> <tr> <td>Z(-40°C) / Z(+20°C)</td> <td>3</td> </tr> </table> <p>(at 120Hz)</p>	Z(-25°C) / Z(+20°C)	2	Z(-40°C) / Z(+20°C)	3								
Z(-25°C) / Z(+20°C)	2												
Z(-40°C) / Z(+20°C)	3												
Load Life	<p>The following specifications shall be satisfied when the capacitors are restored to 20°C after the rated voltage with the rated ripple current is applied (the peak voltage shall not exceed the rated voltage) at 105°C for the specified period of time.</p> <table border="1"> <tr> <td>∅D</td> <td>Life Time</td> </tr> <tr> <td>∅8</td> <td>3,000 hours</td> </tr> <tr> <td>∅10~</td> <td>4,000 hours</td> </tr> </table> <p>Capacitance change ≤ ±25% of the initial value Tanδ ≤ 200% of the initial specified value Leakage current ≤ The initial specified value</p>	∅D	Life Time	∅8	3,000 hours	∅10~	4,000 hours						
∅D	Life Time												
∅8	3,000 hours												
∅10~	4,000 hours												
Shelf Life	<p>The following specifications shall be satisfied when the capacitors are restored to 20°C after exposing them for 1,000 hours at 105°C without voltage applied. The rated voltage shall be applied to the capacitors for a minimum of 30 minutes, at least 24 hours and not more than 48 hours before the measurements.</p> <p>Capacitance change ≤ ±25% of the initial value Tanδ ≤ 200% of the initial specified value Leakage current ≤ 200% of the initial specified value</p>												
Others	Satisfied characteristics KS C IEC 60384-4												

DIMENSIONS OF NXG Series

Unit(mm)

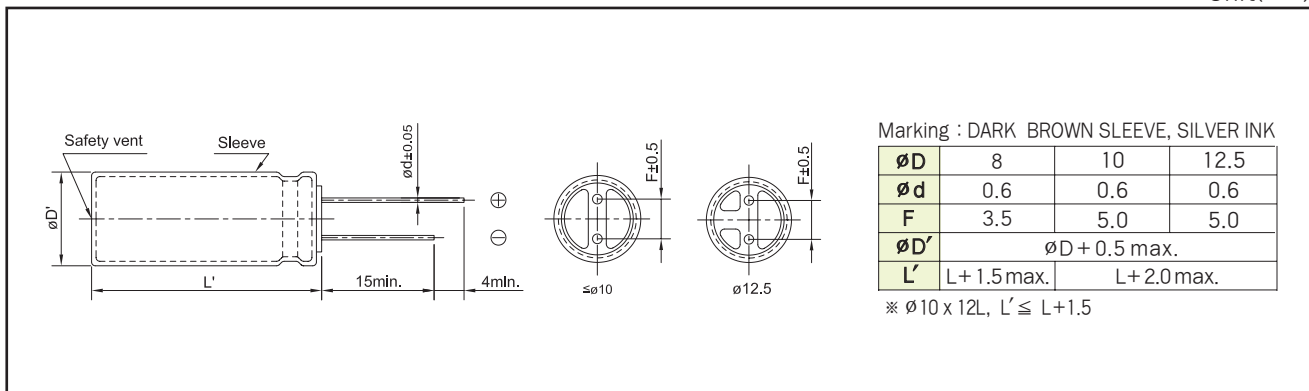

RATINGS OF NXG series

Vdc		6.3			
μF	Items	∅ D × L (mm)	Rated Ripple Current (mA _{RMS} /105°C, 100kHz)	ESR	
				(Ω max./20°C, 100kHz)	(Ω max./-10°C, 100kHz)
820		8 × 11.5	1,700	0.036	0.11
1,200		8 × 15	2,300	0.028	0.085
1,800		8 × 20	2,600	0.019	0.057
1,500		10 × 12	2,200	0.030	0.091
1,500		10 × 12.5	2,200	0.030	0.091
1,800		10 × 16	2,800	0.019	0.057
2,200		10 × 20	3,000	0.013	0.039
3,300		10 × 25	3,270	0.012	0.036

Vdc		10			
μF	Items	∅ D × L (mm)	Rated Ripple Current (mA _{RMS} /105°C, 100kHz)	ESR	
				(Ω max./20°C, 100kHz)	(Ω max./-10°C, 100kHz)
680		8 × 11.5	1,700	0.036	0.11
1,000		8 × 15	2,300	0.028	0.085
1,500		8 × 20	2,600	0.019	0.057
1,000		10 × 12	2,200	0.030	0.091
1,000		10 × 12.5	2,200	0.030	0.091
1,200		10 × 16	2,800	0.019	0.057
1,500		10 × 16	2,800	0.019	0.057
1,800		10 × 20	3,000	0.013	0.039
2,200		10 × 25	3,270	0.012	0.036

Vdc		16			
μF	Items	∅ D × L (mm)	Rated Ripple Current (mA _{RMS} /105°C, 100kHz)	ESR	
				(Ω max./20°C, 100kHz)	(Ω max./-10°C, 100kHz)
470		8 × 11.5	1,700	0.036	0.11
680		8 × 15	2,300	0.028	0.085
1,000		8 × 20	2,600	0.019	0.057
680		10 × 12	2,200	0.030	0.091
680		10 × 12.5	2,200	0.030	0.091
1,000		10 × 16	2,800	0.019	0.057
1,500		10 × 20	3,000	0.013	0.039
1,800		10 × 25	3,270	0.012	0.036

Vdc		25			
μF	Items	∅ D × L (mm)	Rated Ripple Current (mA _{RMS} /105°C, 100kHz)	ESR	
				(Ω max./20°C, 100kHz)	(Ω max./-10°C, 100kHz)
220		8 × 11.5	1,700	0.036	0.11
390		8 × 15	2,300	0.028	0.085
560		8 × 20	2,600	0.019	0.057
470		10 × 12	2,200	0.030	0.091
470		10 × 12.5	2,200	0.030	0.091
680		10 × 16	2,800	0.019	0.057
820		10 × 20	3,000	0.013	0.039
1,000		10 × 25	3,270	0.012	0.036
1,200		12.5 × 20	3,510	0.014	0.042

Vdc		35			
μF	Items	∅ D × L (mm)	Rated Ripple Current (mA _{RMS} /105°C, 100kHz)	ESR	
				(Ω max./20°C, 100kHz)	(Ω max./-10°C, 100kHz)
150		8 × 11.5	1,700	0.036	0.11
270		8 × 15	2,300	0.028	0.085
390		8 × 20	2,600	0.019	0.057
330		10 × 12	2,200	0.030	0.091
330		10 × 12.5	2,200	0.030	0.091
470		10 × 16	2,800	0.019	0.057
560		10 × 20	3,000	0.013	0.039
680		10 × 25	3,270	0.012	0.036

RATED RIPPLE CURRENT MULTIPLIERS

Frequency Multipliers

Cap. (μF)	Freq. (Hz)	120	1k	10k	50k	100k
150 ~ 560		0.50	0.85	0.94	0.96	1.00
680 ~ 1,800		0.60	0.87	0.95	0.97	1.00
2,200 ~ 3,300		0.75	0.90	0.95	0.97	1.00

MLB Series

• 85°C 8,000Hrs assured.

- Non-solvent proof.
- Long Life.
- For LED TV Power, SMPS.
- RoHS compliant.
- Halogen-free capacitors are also available.



SPECIFICATIONS

Item	Characteristics													
Rated Voltage Range	400 V _{DC}	420 ~ 500 V _{DC}												
Operating Temperature Range	-40 ~ + 85°C	-25 ~ + 85°C												
Capacitance Tolerance	±20% (M) (at 20°C, 120Hz)													
Leakage Current	<table border="1"> <thead> <tr> <th>C · V</th> <th>Time</th> <th>After 1 minute</th> <th>After 5 minutes</th> </tr> </thead> <tbody> <tr> <td>≤ 1000</td> <td></td> <td>I = 0.1CV + 40</td> <td>I = 0.03CV + 15</td> </tr> <tr> <td>> 1000</td> <td></td> <td>I = 0.04CV + 100</td> <td>I = 0.02CV + 25</td> </tr> </tbody> </table>		C · V	Time	After 1 minute	After 5 minutes	≤ 1000		I = 0.1CV + 40	I = 0.03CV + 15	> 1000		I = 0.04CV + 100	I = 0.02CV + 25
	C · V	Time	After 1 minute	After 5 minutes										
	≤ 1000		I = 0.1CV + 40	I = 0.03CV + 15										
> 1000		I = 0.04CV + 100	I = 0.02CV + 25											
Where, I:Max. Leakage current(μA), C:Nominal capacitance(μF), V:Rated voltage(V _{DC}) (at 20°C)														
Dissipation Factor(Tanδ)	Rated Voltage(V _{DC})	400 ~ 500												
	Tanδ(Max.)	0.24 (at 20°C, 120Hz)												
Temperature Characteristics (Max. Impedance ratio)	Rated Voltage(V _{DC})	400	420~500											
	Z(-25°C)/Z(+20°C)	5	6											
	Z(-40°C)/Z(+20°C)	6	-											
(at 120Hz)														
Load Life	<p>The following specifications shall be satisfied when the capacitors are restored to 20°C after the rated voltage with the rated ripple current is applied (the peak voltage shall not exceed the rated voltage)for 8,000 hours at 85°C.</p> <p>Capacitance change ≤ ±20% of the initial value Tanδ ≤ 200% of the initial specified value Leakage current ≤ The initial specified value</p>													
Shelf Life	<p>The following specifications shall be satisfied when the capacitors are restored to 20°C after exposing them for 1,000 hours at 85°C without voltage applied. The rated voltage shall be applied to the capacitors for a minimum of 30 minutes, at least 24 hours and not more than 48 hours before the measurements.</p> <p>Capacitance change ≤ ±20% of the initial value Tanδ ≤ 200% of the initial specified value Leakage current ≤ 500% of the initial specified value</p>													
Others	Satisfied characteristics KS C IEC 60384-4													

DIMENSIONS OF MLB Series

Unit(mm)

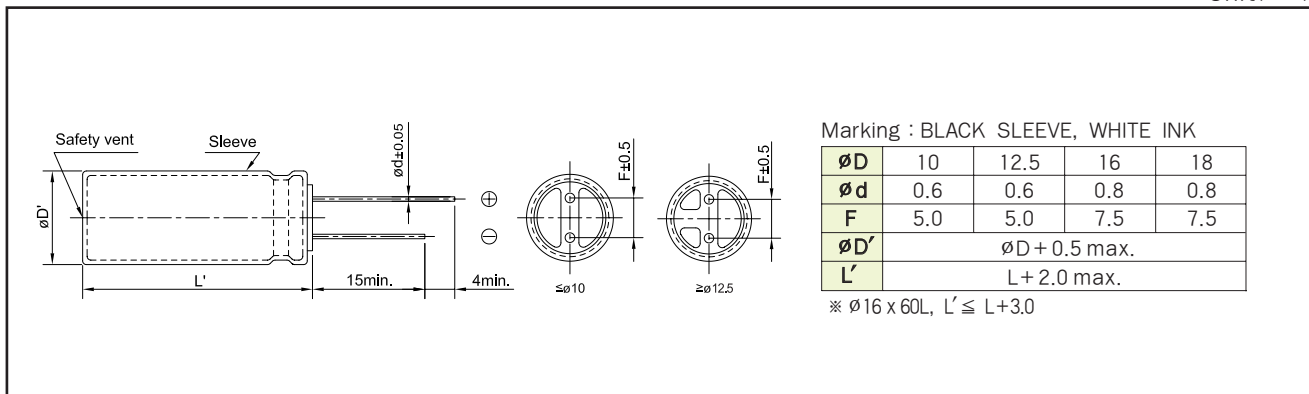

RATINGS OF MLB Series

V _{dc}	Cap.(μ F)	Case size \varnothing D×L(mm)	Rated Ripple Current (mA _{rms} /85°C)				
			120Hz	1KHz	10KHz	50KHz	100KHz
400	68	16 X 31.5	563	704	845	985	1,126
		18 X 25	544	680	816	952	1,088
	82	16 X 35.5	650	813	975	1,138	1,300
		18 X 31.5	650	813	975	1,138	1,300
	100	16 X 40	780	975	1,170	1,365	1,560
		18 X 31.5	700	875	1,050	1,225	1,400
	120	16 X 45	889	1,111	1,334	1,556	1,778
		18 X 35.5	830	1,038	1,245	1,453	1,660
	150	16 X 50	980	1,225	1,470	1,715	1,960
	420	68	16 X 31.5	550	688	825	963
18 X 25			533	666	800	933	1,066
82		16 X 35.5	630	788	945	1,103	1,260
		18 X 31.5	630	788	945	1,103	1,260
100		16 X 40	750	938	1,125	1,500	1,575
		18 X 35.5	720	900	1,080	1,440	1,512
120		16 X 45	840	1,050	1,260	1,700	1,730
		18 X 40	840	1,050	1,260	1,700	1,730
150		16 X 50	920	1,150	1,380	1,760	1,840
450		47	10 X 50	420	525	630	735
	56	12.5 X 40	470	588	705	823	940
	68	12.5 X 45	540	675	810	945	1,080
		16 X 31.5	550	688	825	1,476	1,476
		16 X 35.5	578	723	867	1,012	1,156
		18 X 31.5	560	700	840	980	1,120
	82	12.5 X 50	620	775	930	1,085	1,240
		16 X 35.5	630	788	945	1,103	1,260
		16 X 40	656	820	984	1,500	1,500
		18 X 31.5	630	788	945	1,103	1,260
	100	12.5 X 60	710	888	1,065	1,243	1,420
		16 X 40	720	900	1,080	1,940	1,940
		16 X 45	760	950	1,140	1,940	1,940
		18 X 35.5	720	900	1,080	1,440	1,512
	120	16 X 50	865	1,081	1,298	2,112	2,112
		18 X 40	840	1,050	1,260	1,700	1,730
	150	16 X 50	920	1,150	1,380	1,760	1,840
	500	10	12.5 X 16	115	144	173	201
22		16 X 25	230	288	345	403	460
33		10 X 50	310	388	465	543	620
47		12.5 X 40	380	475	570	665	760
		16 X 35.5	435	544	653	761	870
56		12.5 X 45	460	575	690	805	920
		16 X 40	491	614	737	859	982
68		12.5 X 50	510	638	765	893	1,020
		16 X 40	523	654	785	1,460	1,460
		16 X 45	563	704	845	985	1,126
82		12.5 X 60	600	750	900	1,050	1,200
		16 X 40	580	725	870	1,480	1,480
		16 X 45	610	763	915	1,500	1,500
		16 X 50	630	788	945	1,103	1,260
100		16 X 50	700	875	1,050	1,848	1,848
		18 X 45	700	875	1,050	1,410	1,500
120		16 X 60	830	1,038	1,245	2,070	2,070
		18 X 50	830	1,038	1,245	1,700	1,730

MLC Series

• 85°C 10,000Hrs assured.

- Non-solvent proof.
- Long life.
- For LED TV Power, SMPS.
- RoHS compliant.
- Halogen-free capacitors are also available.



SPECIFICATIONS

Item	Characteristics													
Rated Voltage Range	400 V _{dc}	420 ~ 500 V _{dc}												
Operating Temperature Range	-40 ~ + 85°C	-25 ~ + 85°C												
Capacitance Tolerance	±20%(M) (at 20°C, 120Hz)													
Leakage Current	<table border="1"> <thead> <tr> <th>C · V</th> <th>Time</th> <th>After 1 minute</th> <th>After 5 minutes</th> </tr> </thead> <tbody> <tr> <td>≤ 1000</td> <td></td> <td>I = 0.1CV + 40</td> <td>I = 0.03CV + 15</td> </tr> <tr> <td>> 1000</td> <td></td> <td>I = 0.04CV + 100</td> <td>I = 0.02CV + 25</td> </tr> </tbody> </table> <p>Where, I:Max. Leakage current(μA) C:Nominal capacitance(μF) V:Rated voltage(V_{dc}) (at 20°C)</p>		C · V	Time	After 1 minute	After 5 minutes	≤ 1000		I = 0.1CV + 40	I = 0.03CV + 15	> 1000		I = 0.04CV + 100	I = 0.02CV + 25
C · V	Time	After 1 minute	After 5 minutes											
≤ 1000		I = 0.1CV + 40	I = 0.03CV + 15											
> 1000		I = 0.04CV + 100	I = 0.02CV + 25											
Dissipation Factor(Tanδ)	<table border="1"> <thead> <tr> <th>Rated Voltage(V_{dc})</th> <th>400~500</th> </tr> </thead> <tbody> <tr> <td>Tanδ(Max.)</td> <td>0.24</td> </tr> </tbody> </table> <p>(at 20°C, 120Hz)</p>		Rated Voltage(V _{dc})	400~500	Tanδ(Max.)	0.24								
Rated Voltage(V _{dc})	400~500													
Tanδ(Max.)	0.24													
Temperature Characteristics (Max. Impedance ratio)	<table border="1"> <thead> <tr> <th>Rated Voltage(V_{dc})</th> <th>400</th> <th>420~500</th> </tr> </thead> <tbody> <tr> <td>Z(-25°C)/Z(+20°C)</td> <td>5</td> <td>6</td> </tr> <tr> <td>Z(-40°C)/Z(+20°C)</td> <td>6</td> <td>-</td> </tr> </tbody> </table> <p>(at 120Hz)</p>		Rated Voltage(V _{dc})	400	420~500	Z(-25°C)/Z(+20°C)	5	6	Z(-40°C)/Z(+20°C)	6	-			
Rated Voltage(V _{dc})	400	420~500												
Z(-25°C)/Z(+20°C)	5	6												
Z(-40°C)/Z(+20°C)	6	-												
Load Life	<p>The following specifications shall be satisfied when the capacitors are restored to 20°C after the rated voltage with the rated ripple current is applied (the peak voltage shall not exceed the rated voltage) for 10,000 hours at 85°C.</p> <p>Capacitance change ≤ ±20% of the initial value Tanδ ≤ 200% of the initial specified value Leakage current ≤ The initial specified value</p>													
Shelf Life	<p>The following specifications shall be satisfied when the capacitors are restored to 20°C after exposing them for 1,000 hours at 85°C without voltage applied. The rated voltage shall be applied to the capacitors for a minimum of 30 minutes, at least 24 hours and not more than 48 hours before the measurements.</p> <p>Capacitance change ≤ ±20% of the initial value Tanδ ≤ 200% of the initial specified value Leakage current ≤ 500% of the initial specified value</p>													
Others	Satisfied characteristics KS C IEC 60384-4													

DIMENSIONS OF MLC Series

Unit(mm)

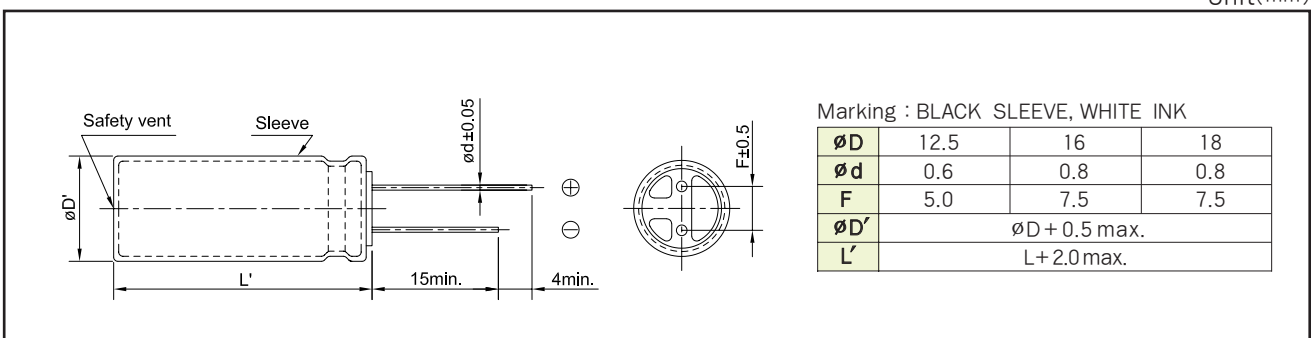

RATINGS OF MLC Series

V _{dc}	Cap.(μ F)	Case size \varnothing D \times L(mm)	Rated Ripple Current (mA _{rms} /85°C)				
			120Hz	1KHz	10KHz	50KHz	100KHz
400	68	16 \times 31.5	676	946	1,013	1,351	1,892
		18 \times 25	653	914	979	1,306	1,828
	82	16 \times 35.5	780	1,092	1,170	1,560	2,184
		18 \times 31.5	780	1,092	1,170	1,560	2,184
	100	16 \times 40	936	1,310	1,404	1,872	2,621
		18 \times 31.5	840	1,176	1,260	1,680	2,352
	120	16 \times 45	1,067	1,494	1,600	2,134	2,987
		18 \times 35.5	996	1,394	1,494	1,992	2,789
	150	16 \times 50	1,176	1,646	1,764	2,352	3,293
	420	68	16 \times 31.5	660	924	990	1,320
18 \times 25			640	896	960	1,280	1,280
82		16 \times 35.5	765	1,071	1,148	1,530	1,530
		18 \times 31.5	765	1,071	1,148	1,530	1,530
100		16 \times 40	870	1,218	1,305	1,740	1,740
		18 \times 35.5	830	1,162	1,245	1,660	1,660
120		16 \times 45	1,020	1,428	1,530	2,040	2,040
		18 \times 40	1,020	1,428	1,530	2,040	2,040
150		16 \times 50	1,104	1,546	1,656	2,208	2,208
450		68	16 \times 35.5	670	838	1,005	1,340
	18 \times 31.5		644	902	966	1,288	1,288
	82	16 \times 40	760	1,064	1,140	1,520	1,520
		18 \times 31.5	760	1,064	1,140	1,520	1,520
	100	16 \times 40	900	1,125	1,350	1,800	1,800
		16 \times 45	912	1,277	1,368	1,824	1,824
	120	18 \times 35.5	900	1,260	1,350	1,800	1,800
		16 \times 50	960	1,344	1,440	1,920	1,920
	18 \times 40	966	1,352	1,449	1,932	1,932	
	150	16 \times 50	1,040	1,456	1,560	2,080	2,080
500	10	12.5 \times 16	129	180	193	258	258
	22	16 \times 25	258	361	386	515	515
	47	16 \times 35.5	430	602	645	860	860
	56	16 \times 40	500	700	750	1,000	1,000
	68	16 \times 40	590	738	885	1,180	1,180
		16 \times 45	600	840	900	1,200	1,200
	82	16 \times 45	630	882	945	1,260	1,260
		16 \times 50	680	952	1,020	1,360	1,360
	100	16 \times 45	840	1,050	1,260	1,680	1,680
		16 \times 50	840	1,176	1,260	1,680	1,680
18 \times 45	840	1,176	1,260	1,680	1,680		

NZE Series

• 105°C 2,000Hrs assured.

- Non-solvent proof.
- Downsized, High Ripple.
- For SMPS, IP-Board, Adaptor.
- RoHS compliant.
- Halogen-free capacitors are also available.

NFD
(KMF)

NZE

Downsized



SPECIFICATIONS

Item	Characteristics													
Rated Voltage Range	160 ~ 400 V _{DC}	420 ~ 500 V _{DC}												
Operating Temperature Range	-40 ~ + 105°C	-25 ~ + 105°C												
Capacitance Tolerance	±20%(M) (at 20°C, 120Hz)													
Leakage Current	<table border="1"> <thead> <tr> <th>C · V \ Time</th> <th>After 1 minute</th> <th>After 5 minutes</th> </tr> </thead> <tbody> <tr> <td>≤ 1000</td> <td>I = 0.1CV + 40</td> <td>I = 0.03CV + 15</td> </tr> <tr> <td>> 1000</td> <td>I = 0.04CV + 100</td> <td>I = 0.02CV + 25</td> </tr> </tbody> </table> <p>Where, I:Max. Leakage current(μA) C:Nominal capacitance(μF) V:Rated voltage(V_{DC}) (at 20°C)</p>		C · V \ Time	After 1 minute	After 5 minutes	≤ 1000	I = 0.1CV + 40	I = 0.03CV + 15	> 1000	I = 0.04CV + 100	I = 0.02CV + 25			
C · V \ Time	After 1 minute	After 5 minutes												
≤ 1000	I = 0.1CV + 40	I = 0.03CV + 15												
> 1000	I = 0.04CV + 100	I = 0.02CV + 25												
Dissipation Factor(Tanδ)	<table border="1"> <thead> <tr> <th>Rated Voltage(V_{DC})</th> <th>160~250</th> <th>350~500</th> </tr> </thead> <tbody> <tr> <td>Tanδ(Max.)</td> <td>0.20</td> <td>0.24</td> </tr> </tbody> </table> <p>(at 20°C, 120Hz)</p>		Rated Voltage(V _{DC})	160~250	350~500	Tanδ(Max.)	0.20	0.24						
Rated Voltage(V _{DC})	160~250	350~500												
Tanδ(Max.)	0.20	0.24												
Temperature Characteristics (Max. Impedance ratio)	<table border="1"> <thead> <tr> <th>Rated Voltage(V_{DC})</th> <th>160~250</th> <th>350~400</th> <th>420~500</th> </tr> </thead> <tbody> <tr> <td>Z(-25°C)/Z(+20°C)</td> <td>3</td> <td>5</td> <td>6</td> </tr> <tr> <td>Z(-40°C)/Z(+20°C)</td> <td>6</td> <td>6</td> <td>—</td> </tr> </tbody> </table> <p>(at 120Hz)</p>		Rated Voltage(V _{DC})	160~250	350~400	420~500	Z(-25°C)/Z(+20°C)	3	5	6	Z(-40°C)/Z(+20°C)	6	6	—
Rated Voltage(V _{DC})	160~250	350~400	420~500											
Z(-25°C)/Z(+20°C)	3	5	6											
Z(-40°C)/Z(+20°C)	6	6	—											
Load Life	<p>The following specifications shall be satisfied when the capacitors are restored to 20°C after the rated voltage with the rated ripple current is applied (the peak voltage shall not exceed the rated voltage)for 2,000 hours at 105°C.</p> <p>Capacitance change ≤ ±20% of the initial value Tanδ ≤ 200% of the initial specified value Leakage current ≤ The initial specified value</p>													
Shelf Life	<p>The following specifications shall be satisfied when the capacitors are restored to 20°C after exposing them for 1,000 hours at 105°C without voltage applied. The rated voltage shall be applied to the capacitors for a minimum of 30 minutes, at least 24 hours and not more than 48 hours before the measurements.</p> <p>Capacitance change ≤ ±20% of the initial value Tanδ ≤ 200% of the initial specified value Leakage current ≤ 500% of the initial specified value</p>													
Others	Satisfied characteristics KS C IEC 60384-4													

DIMENSIONS OF NZE Series

Unit(mm)

Marking : DARK BROWN SLEEVE, SILVER INK

	6.3	8	10	12.5	16	18	20	22	25.4
øD	6.3	8	10	12.5	16	18	20	22	25.4
ød	0.5	0.6	0.6	0.6	0.8	0.8	0.8	1.0	1.0
F	2.5	3.5	5.0	5.0	7.5	7.5	7.5	10.0	10.0
øD'	øD + 0.5 max.								
L'	L + 1.5max.			L + 2.0 max.					

RATINGS OF NZE Series

V _{dc}	Capacitance (μF)	∅D×L(mm)	Rated Ripple Current (mA _{rms} /105°C, 120Hz)
160	22	10 × 20	211
	33	10 × 20	260
	47	10 × 25	338
	68	12.5 × 20	413
	82	12.5 × 25	494
	100	12.5 × 30	589
	120	16 × 20	615
	150	12.5 × 35	710
		16 × 25	738
	180	16 × 25	809
	220	16 × 31.5	964
	270	16 × 35.5	1091
	330	18 × 31.5	1221
		22 × 25	1230
	390	18 × 35.5	1371
		22 × 30	1410
	470	25.4 × 30	1660
	560	22 × 35	1780
		22 × 40	1870
	680	22 × 45	2150
25.4 × 35		2100	
820	22 × 50	2450	
	25.4 × 40	2420	
1000	25.4 × 50	2880	
200	3.3	6.3 × 11	45
	4.7	8 × 11.5	64
	6.8	8 × 11.5	77
	10	8 × 11.5	94
	22	8 × 20	160
	33	10 × 20	260
	47	10 × 25	338
	68	12.5 × 25	413
	82	12.5 × 25	494
	100	12.5 × 30	589
	120	16 × 25	660
	150	16 × 25	738
	180	16 × 31.5	872
	220	16 × 31.5	964
		22 × 25	1030
	270	16 × 35.5	1091
		18 × 31.5	1104
	330	16 × 40	1245
		18 × 35.5	1261
		22 × 30	1290
		25.4 × 30	1280
	390	18 × 40	1393
		22 × 35	1370
	470	22 × 40	1580
		25.4 × 35	1610
	560	22 × 45	1790
		22 × 50	1860
		25.4 × 40	1840
	820	25.4 × 50	2400

V _{dc}	Capacitance (μF)	∅D×L(mm)	Rated Ripple Current (mA _{rms} /105°C, 120Hz)
250	4.7	8 × 11.5	72
	6.8	8 × 11.5	86
	10	8 × 15	108
	22	10 × 20	211
	33	10 × 25	284
	47	12.5 × 20	343
	68	12.5 × 30	488
	82	16 × 25	546
	100	16 × 25	603
	120	16 × 25	660
	150	16 × 31.5	796
	180	16 × 35.5	891
		18 × 31.5	901
		22 × 25	830
	220	16 × 40	1016
		18 × 35.5	1030
		22 × 30	1050
	270	18 × 40	1158
		22 × 35	1140
		25.4 × 30	1160
330	18 × 45	1267	
	22 × 40	1320	
	25.4 × 35	1350	
390	22 × 45	1500	
	25.4 × 40	1530	
470	22 × 50	1710	
560	25.4 × 50	1990	
350	10	10 × 16	118
	15	10 × 20	169
	22	10 × 25	228
	33	12.5 × 25	304
	39	10 × 40	374
	47	16 × 25	400
	56	16 × 25	437
	68	16 × 31.5	510
		18 × 25	502
	82	16 × 35.5	582
		18 × 31.5	590
	100	18 × 31.5	632
		22 × 25	630
	120	18 × 35.5	716
		22 × 30	730
	150	25.4 × 30	880
	180	22 × 35	950
	200	22 × 40	1050
		25.4 × 35	1070
	220	22 × 45	1150
270	22 × 50	1320	
	25.4 × 40	1300	
330	25.4 × 50	1560	

RATED RIPPLE CURRENT MULTIPLIERS

Frequency Multipliers

Freq.(Hz)	120	1K	10K	50K	100K
Factor	1.00	1.25	1.50	1.60	1.75

RATINGS OF NZE Series

V _{dc}	Capacitance (μF)	∅ D×L(mm)	Rated Ripple Current (mA _{rms} /105°C, 120Hz)
400	4.7	6.3 × 15	55
	6.8	8 × 11	101
		8 × 15	102
	8.2	8 × 15	105
		8 × 20	110
	10	8 × 20	115
		10 × 16	118
	15	10 × 20	169
	22	10 × 25	228
	33	12.5 × 25	304
	39	12.5 × 30	355
	47	16 × 25	400
	56	16 × 25	437
	68	16 × 31.5	510
	82	16 × 35.5	582
		18 × 31.5	590
		22 × 25	590
	100	16 × 40	645
		18 × 35.5	786
	120	18 × 40	801
		22 × 30	790
	150	18 × 40	872
		22 × 35	900
25.4 × 30		920	
180	22 × 40	1040	
	25.4 × 35	1060	
200	22 × 45	1140	
220	22 × 50	1250	
	25.4 × 40	1110	
270	25.4 × 50	1400	
330	25.4 × 50	1450	
420	10	10 × 20	129
	15	12.5 × 16	161
	22	12.5 × 20	207
	33	16 × 20	265
	47	16 × 25	374
	56	16 × 31.5	440
	68	18 × 25	492
		18 × 31.5	520
	82	18 × 31.5	640
		22 × 25	550
	100	16 × 45	750
		18 × 35.5	750
		22 × 30	650
	120	16 × 45	780
		18 × 40	819
		22 × 35	750
	150	25.4 × 30	760
		18 × 45	840
		20 × 40	845
		22 × 40	880
	180	25.4 × 35	890
		22 × 45	1000
	200	25.4 × 40	1080
220	22 × 50	1150	
270	25.4 × 50	1360	

V _{dc}	Capacitance (μF)	∅ D×L(mm)	Rated Ripple Current (mA _{rms} /105°C, 120Hz)
450	4.7	8 × 20	80
	8.2	10 × 16	108
	10	10 × 20	129
	15	12.5 × 20	173
	22	12.5 × 25	232
	33	12.5 × 30	292
		16 × 25	306
	39	10 × 45	330
	47	16 × 25	374
	53	10 × 50	424
	56	16 × 31.5	440
	68	16 × 35.5	514
		18 × 31.5	520
		22 × 25	500
	82	12.5 × 50	670
		16 × 40	640
		18 × 31.5	640
	100	12.5 × 60	790
		16 × 45	750
		18 × 35.5	750
	120	22 × 30	740
		16 × 50	819
		18 × 40	819
22 × 35		750	
150	25.4 × 30	760	
	18 × 45	840	
	20 × 40	845	
	22 × 40	880	
180	25.4 × 35	890	
	22 × 45	1000	
	25.4 × 40	1030	
200	22 × 50	1100	
220	25.4 × 50	1230	
500	22	12.5 × 30	238
	33	12.5 × 45	327
	39	12.5 × 50	376
	47	16 × 35.5	385
		18 × 31.5	389
	56	12.5 × 60	473
		16 × 40	452
		22 × 25	450
	60	12.5 × 60	494
	68	16 × 45	567
		18 × 35.5	546
		22 × 30	530
	82	16 × 50	599
		18 × 40	588
		25.4 × 30	620
		18 × 45	700
	100	20 × 40	700
		22 × 35	680
		22 × 40	710
		18 × 50	800
	120	22 × 45	900
		25.4 × 35	800
		25.4 × 40	830
18 × 50		950	
150	22 × 50	950	
180	25.4 × 50	1100	

NZL Series

• 105°C 3,000Hrs assured.

- Non-solvent proof.
- Downsized, High Ripple, Long life.
- For SMPS, IP-Board, Adaptor.
- RoHS compliant.
- Halogen-free capacitors are also available.



SPECIFICATIONS

Item	Characteristics										
Rated Voltage Range	400 V _{DC}	420 ~ 500 V _{DC}									
Operating Temperature Range	-40 ~ + 105°C	-25 ~ + 105°C									
Capacitance Tolerance	±20%(M) (at 20°C, 120Hz)										
Leakage Current	<table border="1"> <thead> <tr> <th>C · V \ Time</th> <th>After 1 minute</th> <th>After 5 minutes</th> </tr> </thead> <tbody> <tr> <td>≤ 1000</td> <td>I = 0.1CV + 40</td> <td>I = 0.03CV + 15</td> </tr> <tr> <td>> 1000</td> <td>I = 0.04CV + 100</td> <td>I = 0.02CV + 25</td> </tr> </tbody> </table> <p>Where, I: Max. Leakage current(μA) C: Nominal capacitance(μF) V: Rated voltage(V_{DC}) (at 20°C)</p>		C · V \ Time	After 1 minute	After 5 minutes	≤ 1000	I = 0.1CV + 40	I = 0.03CV + 15	> 1000	I = 0.04CV + 100	I = 0.02CV + 25
C · V \ Time	After 1 minute	After 5 minutes									
≤ 1000	I = 0.1CV + 40	I = 0.03CV + 15									
> 1000	I = 0.04CV + 100	I = 0.02CV + 25									
Dissipation Factor(Tanδ)	<table border="1"> <thead> <tr> <th>Rated Voltage(V_{DC})</th> <th>400~500</th> </tr> </thead> <tbody> <tr> <td>Tanδ(Max.)</td> <td>0.24</td> </tr> </tbody> </table> <p>(at 20°C, 120Hz)</p>		Rated Voltage(V _{DC})	400~500	Tanδ(Max.)	0.24					
Rated Voltage(V _{DC})	400~500										
Tanδ(Max.)	0.24										
Temperature Characteristics (Max. Impedance ratio)	<table border="1"> <thead> <tr> <th>Rated Voltage(V_{DC})</th> <th>400</th> <th>420~500</th> </tr> </thead> <tbody> <tr> <td>Z(-25°C)/Z(+20°C)</td> <td>5</td> <td>6</td> </tr> <tr> <td>Z(-40°C)/Z(+20°C)</td> <td>6</td> <td>-</td> </tr> </tbody> </table> <p>(at 120Hz)</p>		Rated Voltage(V _{DC})	400	420~500	Z(-25°C)/Z(+20°C)	5	6	Z(-40°C)/Z(+20°C)	6	-
Rated Voltage(V _{DC})	400	420~500									
Z(-25°C)/Z(+20°C)	5	6									
Z(-40°C)/Z(+20°C)	6	-									
Load Life	<p>The following specifications shall be satisfied when the capacitors are restored to 20°C after the rated voltage with the rated ripple current is applied (the peak voltage shall not exceed the rated voltage) for 3,000 hours at 105°C.</p> <p>Capacitance change ≤ ±20% of the initial value Tanδ ≤ 200% of the initial specified value Leakage current ≤ The initial specified value</p>										
Shelf Life	<p>The following specifications shall be satisfied when the capacitors are restored to 20°C after exposing them for 1,000 hours at 105°C without voltage applied. The rated voltage shall be applied to the capacitors for a minimum of 30 minutes, at least 24 hours and not more than 48 hours before the measurements.</p> <p>Capacitance change ≤ ±20% of the initial value Tanδ ≤ 200% of the initial specified value Leakage current ≤ 500% of the initial specified value</p>										
Others	Satisfied characteristics KS C IEC 60384-4										

DIMENSIONS OF NZL Series

Unit(mm)

Marking : DARK BROWN SLEEVE, SILVER INK

øD	10	12.5	16	18	20
ød	0.6	0.6	0.8	0.8	0.8
F	5.0	5.0	7.5	7.5	7.5
øD'	øD + 0.5 max.				
L'	L + 2.0 max.				

RATINGS OF NZL Series

V _{oc}	400		420		450	
μF / Items	$\varnothing D \times L$ (mm)	Rated Ripple Current (mA _{rms} /105°C, 120Hz)	$\varnothing D \times L$ (mm)	Rated Ripple Current (mA _{rms} /105°C, 120Hz)	$\varnothing D \times L$ (mm)	Rated Ripple Current (mA _{rms} /105°C, 120Hz)
10	10 × 16	118	10 × 20	129	10 × 20	129
15	10 × 20	169	12.5 × 16	161	12.5 × 20	173
22	10 × 25	228	12.5 × 20	207	12.5 × 25	263
33	12.5 × 25	304	16 × 20	265	16 × 25	306
47	16 × 25	400	16 × 25	374	16 × 25	374
56	16 × 25	437	16 × 31.5	440	16 × 31.5	440
68	16 × 31.5	550	18 × 25	492	16 × 35.5	514
			18 × 31.5	520	18 × 31.5	520
82	16 × 35.5	582	18 × 31.5	640	16 × 40	640
	18 × 31.5	590			18 × 31.5	
100	16 × 40	645	16 × 40	710	16 × 40	710
	18 × 35.5	786	18 × 35.5	750	18 × 35.5	750
120	18 × 40	801	16 × 45	780	16 × 50	819
			18 × 40	819	18 × 40	
150	18 × 40	872	18 × 45	840	18 × 45	840
			20 × 40	845	20 × 40	845

V _{oc}	500	
μF / Items	$\varnothing D \times L$ (mm)	Rated Ripple Current (mA _{rms} /105°C, 120Hz)
22	12.5 × 30	238
33	18 × 25	310
47	16 × 35.5	385
56	16 × 40	452
68	16 × 45	567
	18 × 35.5	546
82	16 × 50	599
	18 × 40	588
100	18 × 45	700
	20 × 40	
120	18 × 50	800

RATED RIPPLE CURRENT MULTIPLIERS

Frequency Multipliers

Freq. (Hz)	120	1k	10k	50k	100k
Factor	1.00	1.25	1.50	1.75	2.00

NFC Series

• 105°C 2,000~5,000Hrs assured.

- Non-solvent proof.
- High Ripple, Long Life.
- For SMPS, IP-Board, Adaptor.
- RoHS compliant.
- Halogen-free capacitors are also available.



SPECIFICATIONS

Item	Characteristics													
Rated Voltage Range	160 ~ 400 V _{DC}	420 ~ 500 V _{DC}												
Operating Temperature Range	-40 ~ + 105°C	-25 ~ + 105°C												
Capacitance Tolerance	±20%(M) (at 20°C, 120Hz)													
Leakage Current	<table border="1"> <thead> <tr> <th>C · V \ Time</th> <th>After 1 minute</th> <th>After 5 minutes</th> </tr> </thead> <tbody> <tr> <td>≤ 1000</td> <td>I = 0.1CV + 40</td> <td>I = 0.03CV + 15</td> </tr> <tr> <td>> 1000</td> <td>I = 0.04CV + 100</td> <td>I = 0.02CV + 25</td> </tr> </tbody> </table> <p>Where, I: Max. Leakage current(μA) C: Nominal capacitance (μF) V: Rated voltage (V_{DC}) (at 20°C)</p>		C · V \ Time	After 1 minute	After 5 minutes	≤ 1000	I = 0.1CV + 40	I = 0.03CV + 15	> 1000	I = 0.04CV + 100	I = 0.02CV + 25			
C · V \ Time	After 1 minute	After 5 minutes												
≤ 1000	I = 0.1CV + 40	I = 0.03CV + 15												
> 1000	I = 0.04CV + 100	I = 0.02CV + 25												
Dissipation Factor(Tanδ)	<table border="1"> <thead> <tr> <th>Rated Voltage(V_{DC})</th> <th>160~250</th> <th>350~500</th> </tr> </thead> <tbody> <tr> <td>Tanδ(Max.)</td> <td>0.20</td> <td>0.24</td> </tr> </tbody> </table> <p>(at 20°C, 120Hz)</p>		Rated Voltage(V _{DC})	160~250	350~500	Tanδ(Max.)	0.20	0.24						
Rated Voltage(V _{DC})	160~250	350~500												
Tanδ(Max.)	0.20	0.24												
Temperature Characteristics (Max. Impedance ratio)	<table border="1"> <thead> <tr> <th>Rated Voltage(V_{DC})</th> <th>160~250</th> <th>350~400</th> <th>420~500</th> </tr> </thead> <tbody> <tr> <td>Z(-25°C)/Z(+20°C)</td> <td>3</td> <td>5</td> <td>6</td> </tr> <tr> <td>Z(-40°C)/Z(+20°C)</td> <td>6</td> <td>6</td> <td>—</td> </tr> </tbody> </table> <p>(at 120Hz)</p>		Rated Voltage(V _{DC})	160~250	350~400	420~500	Z(-25°C)/Z(+20°C)	3	5	6	Z(-40°C)/Z(+20°C)	6	6	—
Rated Voltage(V _{DC})	160~250	350~400	420~500											
Z(-25°C)/Z(+20°C)	3	5	6											
Z(-40°C)/Z(+20°C)	6	6	—											
Load Life	<p>The following specifications shall be satisfied when the capacitors are restored to 20°C after the rated voltage with the rated ripple current is applied (the peak voltage shall not exceed the rated voltage) for 5,000 hours at 105°C. (where, 2,000 hours for Ø6.3)</p> <p>Capacitance change ≤ ±20% of the initial value Tanδ ≤ 200% of the initial specified value Leakage current ≤ The initial specified value</p>													
Shelf Life	<p>The following specifications shall be satisfied when the capacitors are restored to 20°C after exposing them for 1,000 hours at 105°C without voltage applied. The rated voltage shall be applied to the capacitors for a minimum of 30 minutes, at least 24 hours and not more than 48 hours before the measurements.</p> <p>Capacitance change ≤ ±20% of the initial value Tanδ ≤ 200% of the initial specified value Leakage current ≤ 500% of the initial specified value</p>													
Others	Satisfied characteristics KS C IEC 60384-4													

DIMENSIONS OF NFC Series

Unit(mm)

Marking : DARK BROWN SLEEVE, SILVER INK

øD	6.3	8	10	12.5	16	18	20	22	25.4
ød	0.5	0.6	0.6	0.6	0.8	0.8	0.8	1.0	1.0
F	2.5	3.5	5.0	5.0	7.5	7.5	7.5	10.0	10.0
øD'	øD + 0.5 max.								
L'	L + 1.5max.			L + 2.0 max.					

※ ø8 x 50L, L' ≤ L + 2.0

RATINGS OF NFC Series

V _{dc}	Capacitance (μF)	∅ D × L (mm)	Rated Ripple Current (mA _{rms} /105°C, 120Hz)
160	22	8 × 20	135
		10 × 20	192
	33	10 × 20	236
	47	12.5 × 20	312
	68	10 × 20	380
		12.5 × 25	409
	82	8 × 50	360
	100	16 × 25	548
	150	16 × 25	701
	220	16 × 31.5	876
	330	18 × 31.5	1110
		22 × 25	1120
	390	22 × 30	1300
	470	25.4 × 30	1520
	560	22 × 35	1640
		22 × 40	1720
	680	22 × 45	1970
		25.4 × 35	1930
820	22 × 50	2250	
	25.4 × 40	2220	
1000	25.4 × 50	2650	
200	3.3	6.3 × 11	36
	10	8 × 11.5	75
	22	8 × 20	135
		10 × 20	192
	33	12.5 × 20	262
	47	12.5 × 20	312
	68	8 × 50	320
		12.5 × 25	409
	82	16 × 20	462
	100	16 × 25	548
	150	16 × 25	701
	220	18 × 31.5	906
		22 × 25	910
	330	22 × 30	1190
		25.4 × 30	1270
	390	22 × 35	1370
	470	22 × 40	1570
		25.4 × 35	1600
	560	22 × 45	1790
		22 × 50	1860
25.4 × 40		1830	
25.4 × 50		2400	

V _{dc}	Capacitance (μF)	∅ D × L (mm)	Rated Ripple Current (mA _{rms} /105°C, 120Hz)
250	6.8	8 × 11.5	70
	10	8 × 20	95
		10 × 20	130
	22	10 × 20	193
		12.5 × 20	214
	33	12.5 × 25	285
	47	8 × 50	250
		12.5 × 25	340
	68	16 × 25	452
	100	16 × 31.5	591
	150	18 × 31.5	748
	180	22 × 25	780
	220	18 × 35.5	936
		22 × 30	920
	270	22 × 35	1070
		25.4 × 30	1090
	330	20 × 40	1196
		22 × 40	1240
390	25.4 × 35	1270	
	22 × 45	1410	
470	25.4 × 40	1440	
	22 × 50	1610	
560	25.4 × 50	1870	
350	6.8	8 × 15	65
	10	8 × 20	90
		10 × 20	126
	22	12.5 × 20	207
	33	8 × 50	245
		16 × 20	284
	47	16 × 25	364
	68	16 × 31.5	472
	100	18 × 31.5	591
		22 × 25	530
	120	22 × 30	620
	150	18 × 40	760
		25.4 × 30	740
	180	22 × 35	800
	200	22 × 40	880
		25.4 × 35	900
	220	22 × 45	970
	270	22 × 50	1110
25.4 × 40		1090	
330	25.4 × 50	1310	

RATED RIPPLE CURRENT MULTIPLIERS

Frequency Multipliers

Freq.(Hz)	120	1K	10K	50K	100K
Factor	1.00	1.25	1.50	1.60	1.75

RATINGS OF NFC Series

V _{dc}	Capacitance (μF)	∅D×L(mm)	Rated Ripple Current (mA _{rms} /105°C, 120Hz)
400	1	6.3 × 11	19
	3.3	8 × 11.5	42
	6.8	8 × 15	66
	8.2	8 × 20	80
	10	10 × 16	85
	22	12.5 × 25	225
	27	8 × 50	240
	33	16 × 20	284
	47	16 × 25	364
	68	16 × 31.5	472
	82	18 × 31.5	536
		22 × 25	490
	100	18 × 35.5	611
	120	18 × 40	680
		22 × 30	670
	150	18 × 40	760
		22 × 35	750
	180	25.4 × 30	760
		20 × 40	855
		22 × 40	860
200	25.4 × 35	880	
	22 × 45	940	
220	22 × 45	996	
	22 × 50	1030	
	25.4 × 40	1010	
270	25.4 × 50	1220	
330	25.4 × 50	1260	
420	68	18 × 31.5	500
	82	18 × 31.5	560
		22 × 25	490
	100	18 × 35.5	720
		22 × 30	580
	120	18 × 40	740
		22 × 35	670
		25.4 × 30	680
	150	18 × 45	753
		22 × 40	780
		25.4 × 35	800
	180	22 × 45	900
	200	25.4 × 40	970
220	22 × 50	1030	
270	25.4 × 50	1200	

V _{dc}	Capacitance (μF)	∅D×L(mm)	Rated Ripple Current (mA _{rms} /105°C, 120Hz)
450	1	6.3 × 11	12
	1.5	8 × 11.5	23
	2.2	8 × 15	38
	3.3	8 × 15	42
	4.7	8 × 20	62
	6.8	10 × 20	100
	8.2	10 × 25	121
	10	12.5 × 20	135
	22	8 × 50	230
	27	16 × 25	267
	33	16 × 31.5	319
	47	10 × 50	334
		18 × 25	368
	68	12.5 × 42.5	476
		18 × 31.5	500
		22 × 25	440
	82	12.5 × 50	473
		18 × 31.5	594
	100	12.5 × 60	630
		18 × 35.5	720
		22 × 30	620
		18 × 40	740
	120	22 × 35	650
		25.4 × 30	660
		18 × 45	753
	150	20 × 40	757
		22 × 40	780
25.4 × 35		780	
22 × 45		870	
22 × 50		910	
180	25.4 × 40	890	
	22 × 50	950	
	25.4 × 50	1070	
500	6.8	10 × 20	100
	10	12.5 × 20	135
	15	12.5 × 25	182
	22	12.5 × 30	210
	27	10 × 50	253
	33	16 × 31.5	319
		18 × 25	308
	39	12.5 × 50	358
	40	12.5 × 50	360
	47	18 × 31.5	393
	56	12.5 × 60	440
		22 × 25	390
	60	12.5 × 60	455
	68	18 × 35.5	489
		22 × 30	450
	82	18 × 40	594
		25.4 × 30	530
		18 × 45	620
	100	20 × 40	618
		22 × 35	580
		22 × 40	610
		22 × 45	702
	120	25.4 × 35	680
		25.4 × 40	710
		22 × 50	827
	150	22 × 50	827
	180	25.4 × 50	950

NFK Series

• 105°C 5,000Hrs assured.

- Non-solvent proof.
- High Ripple, Long Life.
- For SMPS, IP-Board, Adaptor.
- RoHS compliant.
- Halogen-free capacitors are also available.

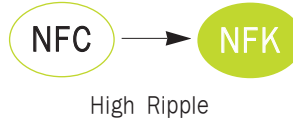

SPECIFICATIONS

Item	Characteristics													
Rated Voltage Range	160 ~ 400 V _{DC}	420 ~ 500 V _{DC}												
Operating Temperature Range	-40 ~ +105°C	-25 ~ +105°C												
Capacitance Tolerance	±20%(M) (at 20°C, 120Hz)													
Leakage Current	<table border="1"> <thead> <tr> <th>C · V \ Time</th> <th>After 1 minute</th> <th>After 5 minutes</th> </tr> </thead> <tbody> <tr> <td>≤ 1000</td> <td>I = 0.1CV + 40</td> <td>I = 0.03CV + 15</td> </tr> <tr> <td>> 1000</td> <td>I = 0.04CV + 100</td> <td>I = 0.02CV + 25</td> </tr> </tbody> </table> <p>Where, I: Max. Leakage current(μA) C: Nominal capacitance (μF) V: Rated voltage (V_{DC})(at 20°C)</p>		C · V \ Time	After 1 minute	After 5 minutes	≤ 1000	I = 0.1CV + 40	I = 0.03CV + 15	> 1000	I = 0.04CV + 100	I = 0.02CV + 25			
C · V \ Time	After 1 minute	After 5 minutes												
≤ 1000	I = 0.1CV + 40	I = 0.03CV + 15												
> 1000	I = 0.04CV + 100	I = 0.02CV + 25												
Dissipation Factor(Tanδ)	<table border="1"> <thead> <tr> <th>Rated Voltage(V_{DC})</th> <th>160~250</th> <th>350~500</th> </tr> </thead> <tbody> <tr> <td>Tanδ(Max.)</td> <td>0.20</td> <td>0.24</td> </tr> </tbody> </table> <p>(at 20°C, 120Hz)</p>		Rated Voltage(V _{DC})	160~250	350~500	Tanδ(Max.)	0.20	0.24						
Rated Voltage(V _{DC})	160~250	350~500												
Tanδ(Max.)	0.20	0.24												
Temperature Characteristics (Max. Impedance ratio)	<table border="1"> <thead> <tr> <th>Rated Voltage(V_{DC})</th> <th>160~250</th> <th>350~400</th> <th>420~500</th> </tr> </thead> <tbody> <tr> <td>Z(-25°C)/Z(+20°C)</td> <td>3</td> <td>5</td> <td>6</td> </tr> <tr> <td>Z(-40°C)/Z(+20°C)</td> <td>6</td> <td>6</td> <td>—</td> </tr> </tbody> </table> <p>(at 120Hz)</p>		Rated Voltage(V _{DC})	160~250	350~400	420~500	Z(-25°C)/Z(+20°C)	3	5	6	Z(-40°C)/Z(+20°C)	6	6	—
Rated Voltage(V _{DC})	160~250	350~400	420~500											
Z(-25°C)/Z(+20°C)	3	5	6											
Z(-40°C)/Z(+20°C)	6	6	—											
Load Life	<p>The following specifications shall be satisfied when the capacitors are restored to 20°C after the rated voltage with the rated ripple current is applied (the peak voltage shall not exceed the rated voltage) for 5,000 hours at 105°C.</p> <p>Capacitance change ≯ ±20% of the initial value Tanδ ≯ 200% of the initial specified value Leakage current ≯ The initial specified value</p>													
Shelf Life	<p>The following specifications shall be satisfied when the capacitors are restored to 20°C after exposing them for 1,000 hours at 105°C without voltage applied. The rated voltage shall be applied to the capacitors for a minimum of 30 minutes, at least 24 hours and not more than 48 hours before the measurements.</p> <p>Capacitance change ≯ ±20% of the initial value Tanδ ≯ 200% of the initial specified value Leakage current ≯ 500% of the initial specified value</p>													
Others	Satisfied characteristics KS C IEC 60384-4													

DIMENSIONS OF NFK Series

Unit(mm)

Marking : DARK BROWN SLEEVE, SILVER INK

øD	8	10	12.5	16	18	20	22	25.4
ød	0.6	0.6	0.6	0.8	0.8	0.8	1.0	1.0
F	3.5	5.0	5.0	7.5	7.5	7.5	10.0	10.0
øD'	øD + 0.5 max.							
L'	L + 1.5 max.		L + 2.0 max.					

※ ø10 x 12L, L' ≤ L + 1.5

RATINGS OF NFK Series

V _{dc}	Capacitance (μF)	∅D×L(mm)	Rated Ripple Current (mA _{rms} /105°C, 120Hz)
160	27	10 × 12	240
		10 × 12.5	240
	33	10 × 20	250
	47	12.5 × 20	340
	68	12.5 × 20	400
		12.5 × 25	436
	100	12.5 × 30	550
	150	16 × 25	736
	220	16 × 31.5	912
	330	18 × 31.5	1200
		22 × 25	1190
	390	22 × 30	1370
	470	25.4 × 30	1610
	560	22 × 35	1740
		22 × 40	1820
	680	22 × 45	2090
		25.4 × 35	2050
	820	22 × 50	2390
25.4 × 40		2350	
1000	25.4 × 50	2810	
200	22	10 × 12	162
		10 × 12.5	162
	25	8 × 20	160
	33	10 × 20	250
	47	12.5 × 20	340
	68	12.5 × 25	436
	100	12.5 × 30	550
	150	16 × 25	736
	220	18 × 31.5	985
		22 × 25	990
	330	22 × 30	1290
		22 × 35	1480
	390	25.4 × 30	1510
		22 × 40	1710
	470	25.4 × 35	1740
		22 × 45	1940
	560	22 × 50	2020
		25.4 × 40	1990
	820	25.4 × 50	2610

V _{dc}	Capacitance (μF)	∅D×L(mm)	Rated Ripple Current (mA _{rms} /105°C, 120Hz)
250	6.8	10 × 12	86
		10 × 12.5	86
	10	8 × 15	95
		10 × 12.5	105
	15	10 × 12	128
		10 × 12.5	128
	22	10 × 16	165
	33	12.5 × 20	250
	47	12.5 × 20	320
		12.5 × 25	375
	68	10 × 40	465
		12.5 × 30	463
	82	12.5 × 35	515
	100	10 × 50	585
		16 × 25	591
	150	18 × 25	721
		12.5 × 50	860
	180	18 × 31.5	813
		22 × 25	820
	220	18 × 31.5	925
22 × 30		960	
270	22 × 35	1130	
	25.4 × 30	1140	
330	22 × 40	1300	
	25.4 × 35	1330	
390	22 × 45	1480	
	25.4 × 40	1510	
470	22 × 50	1690	
560	25.4 × 50	1960	
350	10	8 × 20	120
		10 × 16	125
		10 × 20	130
	22	12.5 × 20	225
		12.5 × 20	249
	33	12.5 × 25	260
		12.5 × 30	380
	47	12.5 × 40	516
		16 × 25	510
	82	18 × 25	620
	100	18 × 31.5	743
		22 × 25	720
	120	22 × 30	840
	150	18 × 35.5	942
		25.4 × 30	1010
	180	18 × 40	1048
		22 × 35	1090
	200	22 × 40	1200
		25.4 × 35	1230
	220	22 × 45	1320
22 × 50		1510	
270	25.4 × 40	1490	
	25.4 × 50	1780	

RATED RIPPLE CURRENT MULTIPLIERS

Frequency Multipliers

Freq.(Hz)	120	1K	10K	50K	100K
Factor	1.00	1.25	1.50	1.75	2.00

RATINGS OF NFK Series

V _{dc}	Capacitance (μF)	∅ D×L(mm)	Rated Ripple Current (mA _{rms} /105°C, 120Hz)
400	6.8	8 × 15	90
	8.2	8 × 20	105
		10 × 12	98
		10 × 12.5	98
		10 × 16	125
	15	10 × 20	150
		12.5 × 16	140
	22	10 × 25	200
	27	12.5 × 20	250
	33	12.5 × 25	295
		16 × 20	305
	47	10 × 45	352
		12.5 × 35	375
		16 × 25	436
	68	12.5 × 40	475
		18 × 25	472
	82	18 × 31.5	700
		22 × 25	590
	100	18 × 35.5	795
	120	18 × 40	912
		22 × 30	760
	150	18 × 40	1020
		22 × 35	900
		25.4 × 30	920
	180	20 × 40	1080
		22 × 40	1040
		25.4 × 35	1060
	200	22 × 45	1140
220	22 × 45	1200	
	22 × 50	1240	
	25.4 × 40	1220	
270	25.4 × 50	1470	
330	25.4 × 50	1520	
420	22	10 × 20	135
	27	12.5 × 20	215
	33	16 × 20	340
		16 × 25	368
	47	18 × 20	375
		18 × 25	500
	82	18 × 31.5	660
		22 × 25	580
	100	18 × 35.5	750
		22 × 30	690
	120	18 × 40	830
		22 × 35	800
	150	25.4 × 30	810
		18 × 45	950
		22 × 40	940
	180	25.4 × 35	980
22 × 45		1080	
200	25.4 × 40	1150	
220	22 × 50	1230	
270	25.4 × 50	1450	

V _{dc}	Capacitance (μF)	∅ D×L(mm)	Rated Ripple Current (mA _{rms} /105°C, 120Hz)
450	4.7	8 × 20	79
	6.8	10 × 16	100
	8.2	10 × 16	122
	10	10 × 20	135
	15	10 × 25	185
	22	10 × 33	215
	27	12.5 × 25	260
	33	12.5 × 30	335
		16 × 20	340
	39	10 × 45	353
	47	10 × 50	400
		12.5 × 40	405
		16 × 25	368
	68	18 × 25	500
		22 × 25	530
	82	12.5 × 50	670
		18 × 31.5	650
	100	12.5 × 60	750
		16 × 45	750
		18 × 35.5	750
		22 × 30	680
	120	16 × 50	800
		18 × 40	800
		22 × 35	790
		25.4 × 30	800
	150	18 × 45	920
		20 × 40	930
		22 × 40	950
		25.4 × 35	980
	180	22 × 45	1070
		22 × 50	1100
		25.4 × 40	1080
200	22 × 50	1150	
220	25.4 × 50	1290	
500	22	12.5 × 30	220
	27	10 × 50	305
	33	12.5 × 45	365
	39	12.5 × 50	425
	47	18 × 31.5	468
	56	22 × 25	470
	60	12.5 × 60	515
	68	16 × 45	585
		18 × 35.5	585
		22 × 30	550
	82	16 × 50	653
		18 × 35.5	640
		18 × 40	653
		25.4 × 30	640
	100	18 × 45	750
		20 × 40	800
		22 × 35	700
		22 × 40	730
120	18 × 50	850	
	22 × 45	900	
	25.4 × 35	820	
	25.4 × 40	860	
150	22 × 50	980	
180	25.4 × 50	1140	

NFS Series

• 105°C 5,000Hrs assured.

- Non-solvent proof.
- High Ripple, Long Life.
- For SMPS, IP-Board, Adaptor.
- RoHS compliant.
- Halogen-free capacitors are also available.

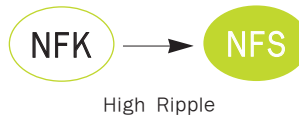

SPECIFICATIONS

Item	Characteristics													
Rated Voltage Range	200~400 V _{DC}	420~500 V _{DC}												
Operating Temperature Range	-40~+105°C	-25~+105°C												
Capacitance Tolerance	±20%(M) (at 20°C, 120Hz)													
Leakage Current	<table border="1"> <thead> <tr> <th>C · V \ Time</th> <th>After 1 minute</th> <th>After 5 minutes</th> </tr> </thead> <tbody> <tr> <td>≤ 1000</td> <td>I = 0.1CV + 40</td> <td>I = 0.03CV + 15</td> </tr> <tr> <td>> 1000</td> <td>I = 0.04CV + 100</td> <td>I = 0.02CV + 25</td> </tr> </tbody> </table> <p>Where, I: Max. Leakage current(μA) C: Nominal capacitance(μF) V: Rated voltage(V_{DC}) (at 20°C)</p>		C · V \ Time	After 1 minute	After 5 minutes	≤ 1000	I = 0.1CV + 40	I = 0.03CV + 15	> 1000	I = 0.04CV + 100	I = 0.02CV + 25			
C · V \ Time	After 1 minute	After 5 minutes												
≤ 1000	I = 0.1CV + 40	I = 0.03CV + 15												
> 1000	I = 0.04CV + 100	I = 0.02CV + 25												
Dissipation Factor(Tanδ)	<table border="1"> <thead> <tr> <th>Rated Voltage(V_{DC})</th> <th>200~250</th> <th>350~500</th> </tr> </thead> <tbody> <tr> <td>Tanδ(Max.)</td> <td>0.20</td> <td>0.24</td> </tr> </tbody> </table> <p>(at 20°C, 120Hz)</p>		Rated Voltage(V _{DC})	200~250	350~500	Tanδ(Max.)	0.20	0.24						
Rated Voltage(V _{DC})	200~250	350~500												
Tanδ(Max.)	0.20	0.24												
Temperature Characteristics (Max. Impedance ratio)	<table border="1"> <thead> <tr> <th>Rated Voltage(V_{DC})</th> <th>200~250</th> <th>350~400</th> <th>420~500</th> </tr> </thead> <tbody> <tr> <td>Z(-25°C)/Z(20°C)</td> <td>3</td> <td>5</td> <td>6</td> </tr> <tr> <td>Z(-40°C)/Z(20°C)</td> <td>6</td> <td>6</td> <td>-</td> </tr> </tbody> </table> <p>(at 120Hz)</p>		Rated Voltage(V _{DC})	200~250	350~400	420~500	Z(-25°C)/Z(20°C)	3	5	6	Z(-40°C)/Z(20°C)	6	6	-
Rated Voltage(V _{DC})	200~250	350~400	420~500											
Z(-25°C)/Z(20°C)	3	5	6											
Z(-40°C)/Z(20°C)	6	6	-											
Load Life	<p>The following specifications shall be satisfied when the capacitors are restored to 20°C after the rated voltage with the rated ripple current is applied (the peak voltage shall not exceed the rated voltage) for 5,000 hours at 105°C.</p> <p>Capacitance change ≤ ±20% of the initial value Tanδ ≤ 200% of the initial specified value Leakage current ≤ The initial specified value</p>													
Shelf Life	<p>The following specifications shall be satisfied when the capacitors are restored to 20°C after exposing them for 1,000 hours at 105°C without voltage applied. The rated voltage shall be applied to the capacitors for a minimum of 30 minutes, at least 24 hours and not more than 48 hours before the measurements.</p> <p>Capacitance change ≤ ±20% of the initial value Tanδ ≤ 200% of the initial specified value Leakage current ≤ 500% of the initial specified value</p>													
Others	Satisfied characteristics KS C IEC 60384-4													

DIMENSIONS OF NFS Series

Unit(mm)

Marking : DARK BROWN SLEEVE, SILVER INK

øD	8	10	12.5	16	18
ød	0.6	0.6	0.6	0.8	0.8
F	3.5	5.0	5.0	7.5	7.5
øD'	øD + 0.5 max.				
L'	L + 1.5 max.		L + 2.0 max.		

※ ø10 x 12L, L' ≤ L + 1.5

RATINGS OF NFS Series

V _{DC}	Cap.(μ F)	Case size ϕ D \times L (mm)	Rated Ripple Current(mArms/105°C)				
			120Hz	1kHz	10kHz	50kHz	100kHz
200	22	8 \times 20	120	240	270	285	300
		10 \times 20	184	440	495	523	550
	33	12.5 \times 20	300	560	630	665	700
	47	12.5 \times 20	340	780	878	926	975
	68	12.5 \times 20	369	880	990	1,045	1,100
		12.5 \times 25	436	1,040	1,170	1,235	1,300
	100	12.5 \times 30	550	775	1,395	1,473	1,550
16 \times 25		600	1,304	1,467	1,549	1,630	
250	6.8	10 \times 12	88	189	213	225	280
	10	10 \times 16	165	224	288	304	320
	22	10 \times 20	200	440	495	523	550
	33	12.5 \times 20	250	476	612	646	680
	47	12.5 \times 20	340	720	810	855	900
	68	16 \times 25	540	1,080	1,215	1,283	1,350
	82	12.5 \times 30	510	1,160	1,305	1,378	1,450
350	10	8 \times 20	120	210	270	285	300
		10 \times 20	135	245	315	333	350
	22	12.5 \times 20	225	520	585	618	650
		12.5 \times 25	270	544	612	646	680
	47	18 \times 20	360	920	1,035	1,093	1,150
68	16 \times 31.5	520	1,120	1,260	1,330	1,400	
400	8.2	8 \times 20	105	293	376	397	418
	10	10 \times 20	120	301	387	409	430
	22	12.5 \times 25	250	624	702	741	780
	33	16 \times 25	325	736	828	874	920
420	10	10 \times 16	98	245	315	333	350
	22	12.5 \times 20	215	384	432	456	480
	33	16 \times 20	340	568	639	675	710
	47	18 \times 20	375	600	675	713	750
	56	18 \times 20	400	640	720	760	800
	68	18 \times 25	500	840	945	998	1,050
	82	18 \times 25	560	880	990	1,045	1,100
	100	18 \times 31.5	700	1,136	1,278	1,349	1,420
		18 \times 31.5	740	1,160	1,305	1,378	1,450
120	18 \times 35.5	760	1,240	1,395	1,473	1,550	
150	18 \times 40	800	1,304	1,467	1,549	1,630	
450	22	12.5 \times 25	235	420	473	499	525
	33	16 \times 20	340	568	639	675	710
	47	16 \times 25	375	600	675	713	750
	68	18 \times 25	500	840	945	998	1,050
	82	18 \times 31.5	650	1,092	1,229	1,297	1,365
	100	18 \times 35.5	750	1,260	1,418	1,496	1,575
	120	18 \times 40	800	1,344	1,512	1,596	1,680
500	68	18 \times 35.5	585	983	1,106	1,167	1,229
	82	18 \times 40	653	1,097	1,234	1,303	1,371
	100	18 \times 45	750	1,260	1,418	1,496	1,575

NBA Series

• 105°C 3,000~5,000Hrs assured.

- Non-solvent proof.
- High Ripple, Long Life, Low Temp.
- For SMPS, IP-Board, Adaptor, LED Lighting.
- RoHS compliant.
- Halogen-free capacitors are also available.
- AEC-Q200 compliant : Please contact us for more details, test data, information.

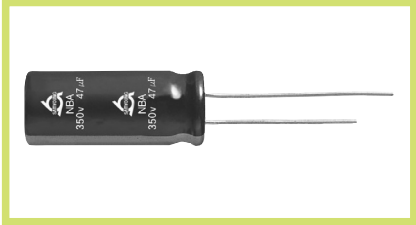

SPECIFICATIONS

Item	Characteristics									
Rated Voltage Range	160~500 V _{DC}									
Operating Temperature Range	-40 ~ +105°C									
Capacitance Tolerance	±20%(M) (at 20°C, 120Hz)									
Leakage Current	<table border="1"> <thead> <tr> <th>C · V \ Time</th> <th>After 1 minute</th> <th>After 5 minutes</th> </tr> </thead> <tbody> <tr> <td>≤ 1000</td> <td>I = 0.1CV + 40</td> <td>I = 0.03CV + 15</td> </tr> <tr> <td>> 1000</td> <td>I = 0.04CV + 100</td> <td>I = 0.02CV + 25</td> </tr> </tbody> </table> <p>Where, I:Max. Leakage current(μA) C:Nominal capacitance(μF) V:Rated voltage(V_{DC}) (at 20°C)</p>	C · V \ Time	After 1 minute	After 5 minutes	≤ 1000	I = 0.1CV + 40	I = 0.03CV + 15	> 1000	I = 0.04CV + 100	I = 0.02CV + 25
C · V \ Time	After 1 minute	After 5 minutes								
≤ 1000	I = 0.1CV + 40	I = 0.03CV + 15								
> 1000	I = 0.04CV + 100	I = 0.02CV + 25								
Dissipation Factor(Tanδ)	<table border="1"> <thead> <tr> <th>Rated Voltage(V_{DC})</th> <th>160~250</th> <th>350~500</th> </tr> </thead> <tbody> <tr> <td>Tanδ(Max.)</td> <td>0.20</td> <td>0.24</td> </tr> </tbody> </table> <p>(at 20°C, 120Hz)</p>	Rated Voltage(V _{DC})	160~250	350~500	Tanδ(Max.)	0.20	0.24			
Rated Voltage(V _{DC})	160~250	350~500								
Tanδ(Max.)	0.20	0.24								
Temperature Characteristics (Max. Impedance ratio)	<table border="1"> <thead> <tr> <th>Rated Voltage(V_{DC})</th> <th>160~500</th> </tr> </thead> <tbody> <tr> <td>Z(-25°C)/Z(20°C)</td> <td>3</td> </tr> <tr> <td>Z(-40°C)/Z(20°C)</td> <td>6</td> </tr> </tbody> </table> <p>(at 120Hz)</p>	Rated Voltage(V _{DC})	160~500	Z(-25°C)/Z(20°C)	3	Z(-40°C)/Z(20°C)	6			
Rated Voltage(V _{DC})	160~500									
Z(-25°C)/Z(20°C)	3									
Z(-40°C)/Z(20°C)	6									
Load Life	<p>The following specifications shall be satisfied when the capacitors are restored to 20°C after the rated voltage with the rated ripple current is applied (the peak voltage shall not exceed the rated voltage) for 5,000 hours at 105°C. (where 3,000hour for Ø6.3)</p> <p>Capacitance change ≤ ±20% of the initial value Tanδ ≤ 200% of the initial specified value Leakage current ≤ The initial specified value</p>									
Shelf Life	<p>The following specifications shall be satisfied when the capacitors are restored to 20°C after exposing them for 1,000 hours at 105°C without voltage applied. The rated voltage shall be applied to the capacitors for a minimum of 30 minutes, at least 24 hours and not more than 48 hours before the measurements.</p> <p>Capacitance change ≤ ±20% of the initial value Tanδ ≤ 200% of the initial specified value Leakage current ≤ 500% of the initial specified value</p>									
Others	Satisfied characteristics KS C IEC 60384-4									

DIMENSIONS OF NBA Series

Unit(mm)

Marking : DARK BLUE SLEEVE, SILVER INK

øD	6.3	8	10	12.5	16	18	20	22	25.4
ød	0.5	0.6	0.6	0.6	0.8	0.8	0.8	1.0	1.0
F	2.5	3.5	5.0	5.0	7.5	7.5	7.5	10.0	10.0
øD'	øD + 0.5 max.								
L'	L + 1.5 max.			L + 2.0 max.					

※ ø10 x 12L, L' ≤ L + 1.5

NBA Series

RATINGS OF NBA Series

V _{dc}	Capacitance (μF)	∅D×L(mm)	Rated Ripple Current (mA _{rms} /105°C, 120Hz)
160	6.8	8 × 11.5	90
	8.2	5 × 15	85
	10	6.3 × 15	106
	15	8 × 15	121
	15	8 × 15	148
	22	10 × 10	205
		10 × 12	221
		10 × 12.5	221
		10 × 16	243
	27	10 × 12	240
		10 × 12.5	240
		10 × 16	264
	33	10 × 16	270
	39	10 × 16	292
	47	10 × 20	369
	68	10 × 20	400
	82	10 × 25	455
		12.5 × 20	495
	100	12.5 × 20	561
	120	10 × 33	638
		12.5 × 25	638
	150	16 × 25	825
	180	16 × 25	891
	220	16 × 31.5	968
		18 × 25	968
	270	16 × 35.5	1100
	330	16 × 40	1256
		18 × 31.5	1231
		22 × 25	1200
	390	22 × 30	1380
470	18 × 40	1541	
	25.4 × 30	1630	
560	22 × 35	1750	
	22 × 40	1830	
680	22 × 45	2110	
	25.4 × 35	2060	
820	22 × 50	2400	
	25.4 × 40	2370	
1000	25.4 × 50	2830	
200	4.7	8 × 11.5	77
	8.2	6.3 × 15	101
	10	8 × 11.5	113
	10	8 × 20	140
	15	8 × 15	148
	22	10 × 12	221
		10 × 12.5	221
		10 × 16	243
	27	10 × 16	264
	33	10 × 20	308
	39	10 × 20	336
	47	10 × 20	369
		12.5 × 20	440
	68	12.5 × 20	492
		12.5 × 25	594
	82	12.5 × 25	616
		16 × 20	616
	100	12.5 × 30	700
		16 × 25	717
	120	12.5 × 35	815
		16 × 25	785
	150	16 × 25	836
	180	16 × 31.5	935
	220	18 × 31.5	1100
		22 × 25	1100
	270	18 × 35.5	1265
	330	18 × 40	1375
		22 × 30	1190
	390	22 × 35	1360
		25.4 × 30	1380
	470	22 × 40	1570
		25.4 × 35	1600
		22 × 45	1780
	560	22 × 50	1850
		25.4 × 40	1830
		25.4 × 50	2390

V _{dc}	Capacitance (μF)	∅D×L(mm)	Rated Ripple Current (mA _{rms} /105°C, 120Hz)
250	4.7	8 × 15	80
	6.8	8 × 20	106
		10 × 12	119
		10 × 12.5	119
	10	10 × 12	160
		10 × 12.5	160
	15	10 × 12	174
		10 × 12.5	174
	22	10 × 16	230
	27	10 × 20	270
	33	12.5 × 20	323
	39	12.5 × 20	354
	47	12.5 × 20	440
	68	12.5 × 25	594
	82	12.5 × 30	660
	100	16 × 25	717
	120	16 × 25	785
	150	18 × 25	902
	180	18 × 31.5	1012
		22 × 25	900
	220	18 × 31.5	1100
		22 × 30	1060
	270	22 × 35	1240
		25.4 × 30	1260
	330	22 × 40	1440
		25.4 × 35	1460
	390	22 × 45	1620
		25.4 × 40	1660
	470	22 × 50	1860
	560	25.4 × 50	2160
350	4.7	8 × 11.5	93
	6.8	8 × 15	101
	10	10 × 12	153
		10 × 12.5	153
		10 × 16	158
	15	10 × 20	197
	22	12.5 × 20	297
	27	12.5 × 20	314
	33	12.5 × 20	319
	39	12.5 × 25	352
	47	12.5 × 30	451
	68	16 × 25	605
	82	18 × 25	688
	100	18 × 31.5	817
		22 × 25	800
	120	18 × 35.5	924
		22 × 30	930
	150	18 × 35.5	1036
		25.4 × 30	1110
	180	18 × 40	1155
		22 × 35	1200
	200	22 × 40	1330
		25.4 × 35	1350
	220	22 × 45	1450
	270	22 × 50	1670
		25.4 × 40	1650
	330	25.4 × 50	1970

RATED RIPPLE CURRENT MULTIPLIERS

Frequency Multipliers

Cap.(μF) \ Freq.(Hz)	120	1K	10K	50K	100K
1 ~ 82	1.00	1.75	2.25	2.35	2.50
100 ~ 1000	1.00	1.67	2.05	2.15	2.25

RATINGS OF NBA Series

V _{DC}	Capacitance (μF)	∅D×L(mm)	Rated Ripple Current (mA _{rms} /105°C, 120Hz)
400	1	6.3 × 11	22
	1.5	6.3 × 15	32
		8 × 11.5	34
	2.2	8 × 11.5	41
	3.3	8 × 11.5	50
	4.7	8 × 11.5	60
	6.8	8 × 15	94
	8.2	8 × 20	119
		10 × 12	132
		10 × 12.5	132
	10	10 × 16	145
	22	12.5 × 20	297
	27	12.5 × 20	314
	33	12.5 × 25	343
	39	12.5 × 25	352
		12.5 × 30	378
	47	12.5 × 35	462
		16 × 25	480
	68	12.5 × 40	550
		18 × 25	627
	82	18 × 31.5	770
		22 × 25	710
	100	18 × 31.5	817
		18 × 35.5	875
	120	18 × 35.5	924
		18 × 40	1003
		22 × 30	910
	150	18 × 40	1122
		22 × 35	1170
		25.4 × 30	1180
	180	18 × 45	1188
		20 × 40	1188
		22 × 40	1230
200	25.4 × 35	1250	
	22 × 45	1360	
220	22 × 50	1480	
	25.4 × 40	1460	
270	25.4 × 50	1750	
330	25.4 × 50	1810	
420	1	6.3 × 11	17
	1.5	6.3 × 15	24
		8 × 11.5	26
	2.2	8 × 11.5	30
	3.3	8 × 11.5	37
	4.7	8 × 11.5	44
	6.8	8 × 20	105
	8.2	10 × 16	113
	10	10 × 20	135
	22	12.5 × 20	225
	27	12.5 × 20	254
	33	12.5 × 30	340
		16 × 20	345
	39	12.5 × 35	380
		16 × 25	400
	47	12.5 × 40	450
		16 × 25	450
	68	18 × 25	520
		18 × 31.5	580
	82	18 × 25	600
		18 × 31.5	650
		22 × 25	630
	100	16 × 45	770
		18 × 35.5	770
		22 × 30	740
	120	16 × 50	850
		18 × 40	850
		22 × 35	860
		25.4 × 30	870
	150	18 × 45	1000
		20 × 40	1000
		22 × 40	1000
		25.4 × 35	1020
180	22 × 45	1150	
200	25.4 × 40	1240	
220	22 × 50	1320	
270	25.4 × 50	1560	

V _{DC}	Capacitance (μF)	∅D×L(mm)	Rated Ripple Current (mA _{rms} /105°C, 120Hz)
450	1	6.3 × 11	17
	1.5	6.3 × 15	24
		8 × 11.5	26
	2.2	8 × 15	33
	3.3	8 × 11.5	37
	4.7	10 × 12	76
		10 × 12.5	76
	6.8	8 × 20	105
	8.2	10 × 16	113
	10	10 × 20	135
	22	12.5 × 25	250
	27	12.5 × 25	265
	33	12.5 × 30	340
		16 × 20	345
	39	12.5 × 35	380
		16 × 25	400
	47	12.5 × 40	450
		16 × 25	450
	68	18 × 25	560
		18 × 31.5	590
		22 × 25	560
	82	16 × 40	650
		18 × 31.5	650
		22 × 30	660
	100	16 × 45	770
		18 × 35.5	770
		25.4 × 30	780
	120	16 × 50	850
		18 × 40	850
		22 × 35	850
		22 × 40	880
	150	25.4 × 35	900
		22 × 45	1030
180	25.4 × 40	1050	
	22 × 50	1170	
220	25.4 × 50	1380	
500	3.3	10 × 12	63
	4.7	10 × 12.5	63
		10 × 12	75
	6.8	10 × 12.5	75
		10 × 16	110
	8.2	10 × 20	141
	10	12.5 × 20	165
	22	12.5 × 30	260
	27	12.5 × 40	329
	33	12.5 × 45	370
		16 × 25	350
	39	12.5 × 50	420
		16 × 31.5	413
	47	16 × 35.5	462
		18 × 31.5	468
	56	22 × 25	510
		16 × 45	630
	68	18 × 35.5	600
		22 × 30	600
		16 × 50	685
	82	18 × 40	670
		25.4 × 30	700
		18 × 45	800
	100	20 × 40	800
		22 × 35	800
		22 × 40	800
	120	18 × 50	920
		22 × 45	920
		25.4 × 35	900
	150	25.4 × 40	940
		22 × 50	980
	180	25.4 × 50	1250

NBR Series

• 105°C 3,000~5,000Hrs assured.

- Non-solvent proof.
- High Ripple, Long Life, Low Temp.
- For SMPS, IP-Board, Adaptor, LED Lighting
- RoHS compliant.
- Halogen-free capacitors are also available.

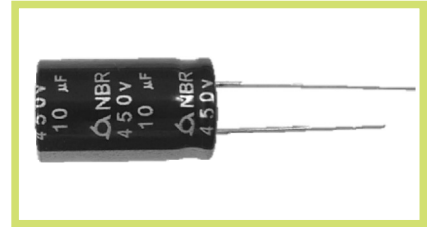
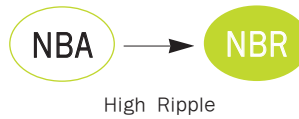

SPECIFICATIONS

Item	Characteristics										
Rated Voltage Range	160~500 V _{DC}	550 V _{DC}									
Operating Temperature Range	-40~ +105°C	-25~ +105°C									
Capacitance Tolerance	±20%(M) (at 20°C, 120Hz)										
Leakage Current	<table border="1"> <thead> <tr> <th>C · V \ Time</th> <th>After 1 minute</th> <th>After 5 minutes</th> </tr> </thead> <tbody> <tr> <td>≤ 1000</td> <td>I = 0.1CV + 40</td> <td>I = 0.03CV + 15</td> </tr> <tr> <td>> 1000</td> <td>I = 0.04CV + 100</td> <td>I = 0.02CV + 25</td> </tr> </tbody> </table>		C · V \ Time	After 1 minute	After 5 minutes	≤ 1000	I = 0.1CV + 40	I = 0.03CV + 15	> 1000	I = 0.04CV + 100	I = 0.02CV + 25
	C · V \ Time	After 1 minute	After 5 minutes								
	≤ 1000	I = 0.1CV + 40	I = 0.03CV + 15								
> 1000	I = 0.04CV + 100	I = 0.02CV + 25									
Where, I:Max. Leakage current(μA) C:Nominal capacitance(μF) V:Rated voltage(V _{DC}) (at 20°C)											
Dissipation Factor(Tanδ)	<table border="1"> <thead> <tr> <th>Rated Voltage(V_{DC})</th> <th>160~250</th> <th>350~550</th> </tr> </thead> <tbody> <tr> <td>Tanδ(Max.)</td> <td>0.20</td> <td>0.24</td> </tr> </tbody> </table>		Rated Voltage(V _{DC})	160~250	350~550	Tanδ(Max.)	0.20	0.24			
	Rated Voltage(V _{DC})	160~250	350~550								
Tanδ(Max.)	0.20	0.24									
(at 20°C, 120Hz)											
Temperature Characteristics (Max. Impedance ratio)	<table border="1"> <thead> <tr> <th>Rated Voltage(V_{DC})</th> <th>160~500</th> <th>550</th> </tr> </thead> <tbody> <tr> <td>Z(-25°C)/Z(+20°C)</td> <td>3</td> <td>6</td> </tr> <tr> <td>Z(-40°C)/Z(+20°C)</td> <td>6</td> <td>-</td> </tr> </tbody> </table>		Rated Voltage(V _{DC})	160~500	550	Z(-25°C)/Z(+20°C)	3	6	Z(-40°C)/Z(+20°C)	6	-
	Rated Voltage(V _{DC})	160~500	550								
	Z(-25°C)/Z(+20°C)	3	6								
Z(-40°C)/Z(+20°C)	6	-									
(at 120Hz)											
Load Life	<p>The following specifications shall be satisfied when the capacitors are restored to 20°C after the rated voltage with the rated ripple current is applied (the peak voltage shall not exceed the rated voltage) for 5,000 hours at 105°C. (where 3,000hour for ø6.3)</p> <p>Capacitance change ≤ ±20% of the initial value Tanδ ≤ 200% of the initial specified value Leakage current ≤ The initial specified value</p>										
Shelf Life	<p>The following specifications shall be satisfied when the capacitors are restored to 20°C after exposing them for 1,000 hours at 105°C without voltage applied. The rated voltage shall be applied to the capacitors for a minimum of 30 minutes, at least 24 hours and not more than 48 hours before the measurements.</p> <p>Capacitance change ≤ ±20% of the initial value Tanδ ≤ 200% of the initial specified value Leakage current ≤ 500% of the initial specified value</p>										
Others	Satisfied characteristics KS C IEC 60384-4										

DIMENSIONS OF NBR Series

Unit(mm)

Marking : DARK BLUE SLEEVE, SILVER INK

	6.3	8	10	12.5	16	18	20	22
øD	6.3	8	10	12.5	16	18	20	22
ød	0.5	0.6	0.6	0.6	0.8	0.8	0.8	1.0
F	2.5	3.5	5.0	5.0	7.5	7.5	7.5	10.0
øD'	øD + 0.5 max.							
L'	L + 1.5 max.		L + 2.0 max.					

※ ø10 x 12L, L' ≤ L + 1.5
 ※ ø16 x 60L, L' ≤ L + 3.0



RATINGS OF NBR Series

V _{dc}		160		200		250		350	
Items	∅ D×L (mm)	Rated Ripple Current (mA _{rms} /105°C, 120Hz)	∅ D×L (mm)	Rated Ripple Current (mA _{rms} /105°C, 120Hz)	∅ D×L (mm)	Rated Ripple Current (mA _{rms} /105°C, 120Hz)	∅ D×L (mm)	Rated Ripple Current (mA _{rms} /105°C, 120Hz)	
4.7			8×11.5	85	8×15	88	8×11.5	102	
6.8	8×11.5	99	8×15	113	8×20	117	8×15	111	
					10×12	149			
					10×12.5	131			
10	8×15	133	8×11.5	124	10×12	176	10×12	160	
			8×20	154	10×12.5	176	10×12.5	160	
					10×16	176	10×16	168	
15	8×15	163	8×15	163	10×12	191	10×20	217	
					10×12.5	191			
22	10×12	260	10×12	243	10×16	253	12.5×20	327	
	10×12.5	260	10×12.5	243					
	10×16	316	10×16	267					
27	10×12	300	10×16	291	10×20	297	12.5×20	345	
	10×12.5	300							
	10×16	343							
33	10×16	345	10×20	339	12.5×20	356	12.5×20	351	
39	10×16	350	10×20	369	12.5×20	390	12.5×25	387	
			10×20	405	12.5×20	484	12.5×30	496	
47	10×20	405	12.5×20	484	12.5×25	653	16×25	666	
			12.5×20	541					
			12.5×25	653					
68	10×20	484	12.5×25	678	12.5×30	726	18×25	756	
82	10×25	545	16×20	678	16×25	789	18×31.5	899	
	12.5×20	545	12.5×30	770					
100	12.5×20	617	12.5×30	770	16×25	864	18×35.5	1016	
			16×25	789					
120	10×33	702	12.5×35	897	18×25	992	18×35.5	1140	
	12.5×25	702	16×25	864					
150	16×25	908	16×25	920	18×25	992	18×35.5	1140	
180	16×25	980	16×31.5	1029	18×31.5	1113	18×40	1272	
220	16×31.5	1065	18×31.5	1210	18×31.5	1210			
	18×25	1065							
270	16×35.5	1210	18×35.5	1392					
330	16×40	1382	18×40	1513					
	18×31.5	1354							
470	18×40	1695							

V _{dc}		400		420		450		500	
Items	∅ D×L (mm)	Rated Ripple Current (mA _{rms} /105°C, 120Hz)	∅ D×L (mm)	Rated Ripple Current (mA _{rms} /105°C, 120Hz)	∅ D×L (mm)	Rated Ripple Current (mA _{rms} /105°C, 120Hz)	∅ D×L (mm)	Rated Ripple Current (mA _{rms} /105°C, 120Hz)	
1	6.3×11	24	6.3×11	19	6.3×11	19			
1.5	6.3×15	35	6.3×15	26	6.3×15	26			
	8×11.5	37	8×11.5	29	8×11.5	29			
2.2	8×11.5	45	8×11.5	33	8×15	36			
3.3	8×11.5	55	8×11.5	41	8×11.5	41	10×12	69	
							10×12.5	69	
4.7	8×11.5	66	8×11.5	48	10×12	84	10×12	83	
					10×12.5	84	10×12.5	83	
6.8	8×15	103	8×20	116	8×20	116	10×16	121	
	8×20	131	10×16	124	10×16	124	10×20	155	
	10×12	145							
	10×12.5	145							
10	10×16	160	10×20	149	10×20	149	12.5×20	182	
22	12.5×20	327	12.5×20	248	12.5×25	275	12.5×30	286	
	12.5×20	345	12.5×20	279	12.5×25	292	12.5×40	362	
33	12.5×25	378	12.5×30	374	12.5×30	374	12.5×45	407	
			16×20	380	16×20	380	16×25	385	
39	12.5×25	387	12.5×35	418	12.5×35	418	12.5×50	462	
	12.5×30	416	16×25	440	16×25	440	16×31.5	454	
47	12.5×35	508	12.5×40	495	12.5×40	495	16×35.5	508	
	16×25	528	16×25	495	16×25	495	18×31.5	515	
68	12.5×40	605	18×25	572	18×25	616	16×45	693	
	18×25	690	18×31.5	638	18×31.5	649	18×35.5	660	
82	18×31.5	847	18×25	660	16×40	715	16×50	754	
			18×31.5	715	18×31.5	715	18×40	737	
100	18×31.5	899	16×45	847	16×45	847	18×45	880	
	18×35.5	962	18×35.5	847	18×35.5	847	20×40	880	
							22×35	880	
120	18×35.5	1,016	16×50	935	16×50	935	18×50	1012	
	18×40	1,104	18×40	935	18×40	935			
150	18×40	1,234	18×45	1,100					
180	18×45	1,307	20×40	1,100					
	20×40	1,307							

RATINGS OF NBR Series

V _{DC}	550	
Items μF	∅ D × L (mm)	Rated Ripple Current (mA _{RMS} /105°C, 120Hz)
3.3	10x12	46
	10x12.5	46
4.7	10x16	60
6.8	10x20	78
8.2	10x20	85
10	10x25	102
	12.5x20	104
22	12.5x30	178
27	12.5x35	207
	16x25	207
33	12.5x40	241
	16x31.5	241
	18x25	241
39	12.5x50	281
	16x35.5	281
47	16x40	312
	18x31.5	312
68	16x50	408
	18x40	408
82	16x60	486
	18x50	486

RATED RIPPLE CURRENT MULTIPLIERS

Frequency Multipliers

Cap. (μF) \ Freq. (Hz)	120	1k	10k	50k	100k
1 ~ 82	1.00	1.75	2.25	2.35	2.50
100 ~ 470	1.00	1.67	2.05	2.15	2.25

NBS Series

• 105°C 5,000Hrs assured

- Non-solvent proof.
- High ripple, Long Life, Low Temp.
- For SMPS, IP-Board, Adaptor, LED Lighting
- RoHS compliant.
- Halogen-free capacitors are also available.

• AEC-Q200 compliant : Please contact us for more details, test data, information.

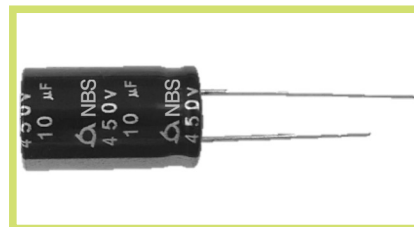
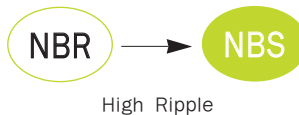

SPECIFICATIONS

Item	Characteristics											
Rated Voltage Range	160 ~ 500 V _{DC}											
Operating Temperature Range	-40 ~ +105°C											
Capacitance Tolerance	±20% (M) (at 20°C, 120Hz)											
Leakage Current	<table border="1"> <thead> <tr> <th>CV</th> <th>Time</th> <th>After 1 minute</th> <th>After 5 minutes</th> </tr> </thead> <tbody> <tr> <td rowspan="2">≤ 1000</td> <td></td> <td>I = 0.1CV + 40</td> <td>I = 0.03CV + 15</td> </tr> <tr> <td></td> <td>I = 0.04CV + 100</td> <td>I = 0.02CV + 25</td> </tr> </tbody> </table> <p>Where, I : Max. Leakage current(μA) C : Nominal capacitance(μF) V : Rated voltage(V_{DC}) (at 20°C)</p>	CV	Time	After 1 minute	After 5 minutes	≤ 1000		I = 0.1CV + 40	I = 0.03CV + 15		I = 0.04CV + 100	I = 0.02CV + 25
CV	Time	After 1 minute	After 5 minutes									
≤ 1000		I = 0.1CV + 40	I = 0.03CV + 15									
		I = 0.04CV + 100	I = 0.02CV + 25									
Dissipation Factor(Tanδ)	<table border="1"> <thead> <tr> <th>Rated Voltage(V_{DC})</th> <th>160 ~ 250</th> <th>350 ~ 500</th> </tr> </thead> <tbody> <tr> <td>Tanδ(Max.)</td> <td>0.20</td> <td>0.24</td> </tr> </tbody> </table> <p>(at 20°C, 120Hz)</p>	Rated Voltage(V _{DC})	160 ~ 250	350 ~ 500	Tanδ(Max.)	0.20	0.24					
Rated Voltage(V _{DC})	160 ~ 250	350 ~ 500										
Tanδ(Max.)	0.20	0.24										
Temperature Characteristics (Max. Impedance ratio)	<table border="1"> <thead> <tr> <th>Rated Voltage(V_{DC})</th> <th>160 ~ 500</th> </tr> </thead> <tbody> <tr> <td>Z(-25°C)/Z(+20°C)</td> <td>3</td> </tr> <tr> <td>Z(-40°C)/Z(+20°C)</td> <td>6</td> </tr> </tbody> </table> <p>(at 120Hz)</p>	Rated Voltage(V _{DC})	160 ~ 500	Z(-25°C)/Z(+20°C)	3	Z(-40°C)/Z(+20°C)	6					
Rated Voltage(V _{DC})	160 ~ 500											
Z(-25°C)/Z(+20°C)	3											
Z(-40°C)/Z(+20°C)	6											
Load Life	<p>The following specifications shall be satisfied when the capacitors are restored to 20°C after the rated voltage with the rated ripple current is applied (the peak voltage shall not exceed the rated voltage) for 5,000 hours at 105°C.</p> <p>Capacitance change ≤ ±20 % of the initial value tan δ ≤ 200 % of the initial specified value Leakage current ≤ The initial specified value</p>											
Shelf Life	<p>The following specifications shall be satisfied when the capacitors are restored to 20°C after exposing them for 1,000 hours at 105°C without voltage applied. The rated voltage shall be applied to the capacitors for a minimum of 30 minutes, at least 24 hours and not more than 48 hours before the measurements.</p> <p>Capacitance change ≤ ±20 % of the initial value tan δ ≤ 200 % of the initial specified value Leakage current ≤ 500% of the initial specified value</p>											
Others	Satisfied characteristics KS C IEC 60384-4											

DIMENSIONS OF NBS Series

Unit(mm)

Marking : DARK BLUE SLEEVE, SILVER INK

	10	12.5	16	18	20	22
øD	10	12.5	16	18	20	22
ød	0.6	0.6	0.8	0.8	0.8	1.0
F	5.0	5.0	7.5	7.5	7.5	10.0
øD'	øD + 0.5 max.					
L'	L + 2.0 max.					

※ ø10 x 12L, L' ≤ L + 1.5

RATINGS OF NBS Series

V _{dc}	160		200		250		350	
Items μF	∅ D×L(mm)	Rated Ripple Current (mA _{rms} /105°C, 120Hz)	∅ D×L(mm)	Rated Ripple Current (mA _{rms} /105°C, 120Hz)	∅ D×L(mm)	Rated Ripple Current (mA _{rms} /105°C, 120Hz)	∅ D×L(mm)	Rated Ripple Current (mA _{rms} /105°C, 120Hz)
10					10×12	180	10×12	168
					10×12.5	180	10×12.5	168
15					10×12	204	10×16	176
					10×12.5	204	10×20	228
22	10×12	286	10×12	276	10×16	278	12.5×20	343
	10×12.5	286	10×12.5	276				
	10×16	335	10×16	290				
27	10×12	330	10×16	315	10×20	327	12.5×20	362
	10×12.5	330						
	10×16	368						
33	10×16	360	10×20	373	12.5×20	391	12.5×20	369
39	10×16	365	10×20	405	12.5×20	429	12.5×25	406
47	10×20	436	10×20	436	12.5×20	494	12.5×30	521
			12.5×20	494				
68	10×20	515	12.5×20	595	12.5×25	665	16×25	699
			12.5×25	665				
82	10×25	575	12.5×25	711	12.5×30	782	18×25	794
	12.5×20	575	16×20	711				
100	12.5×20	650	12.5×30	835	16×25	828	18×31.5	944
			16×25	835				
120	10×33	745	12.5×35	965	16×25	907	18×35.5	1067
	12.5×25	745	16×25	927				
150	16×25	935	16×25	953	18×25	1042	18×35.5	1197
180	16×25	1029	16×31.5	1080	18×31.5	1169	18×40	1336
220	16×31.5	1118	18×31.5	1310	18×31.5	1271		
	18×25	1118						
270	16×35.5	1271	18×35.5	1461				
330	16×40	1451	18×40	1588				
	18×31.5	1422						
470	18×40	1780						

V _{dc}	400		420		450		500	
Items μF	∅ D×L(mm)	Rated Ripple Current (mA _{rms} /105°C, 120Hz)	∅ D×L(mm)	Rated Ripple Current (mA _{rms} /105°C, 120Hz)	∅ D×L(mm)	Rated Ripple Current (mA _{rms} /105°C, 120Hz)	∅ D×L(mm)	Rated Ripple Current (mA _{rms} /105°C, 120Hz)
6.8							10×16	125
8.2	10×12	152	10×16	130	10×16	130	10×20	158
	10×12.5	152						
10	10×16	168	10×20	160	10×20	160	12.5×20	185
22	12.5×20	343	12.5×20	260	12.5×25	285	12.5×30	290
27	12.5×20	362	12.5×20	288	12.5×25	325	12.5×40	368
33	12.5×25	397	12.5×30	385	12.5×30	385	12.5×45	415
			16×20	390	16×20	390	16×25	395
39	12.5×25	406	12.5×35	428	12.5×35	428	12.5×50	470
	12.5×30	437	16×25	450	16×25	450	16×31.5	460
47	12.5×35	533	12.5×40	520	12.5×40	520	16×35.5	525
	16×25	554	16×25	520	16×25	520	18×31.5	525
68	12.5×40	635	18×25	620	18×25	620	16×45	700
	18×25	725			18×31.5	660	18×35.5	685
82	18×31.5	889	18×25	678	16×40	730	16×50	760
			18×31.5	730	18×31.5	730	18×40	745
100	18×31.5	944	16×45	860	16×45	855	18×45	900
	18×35.5	1,010	18×35.5	860	18×35.5	855	20×40	900
120	18×35.5	1,067	16×50	950	16×50	950	18×50	1050
	18×40	1,159	18×40	950	18×40	950		
150	18×40	1,296	16×50	1,150				
180	18×45	1,372	18×45	1,150				
	20×40	1,372						

RATED RIPPLE CURRENT MULTIPLIERS

Frequency Multipliers

Cap.(μF)	Freq.(Hz)	120	1k	10k	50k	100k
1~82		1.00	1.75	2.25	2.35	2.50
100~470		1.00	1.67	2.05	2.15	2.25

NFA Series

• 105°C 7,000~10,000Hrs assured.

- Non-solvent proof.
- High Ripple, Long Life.
- For ballasts stabilizer.
- RoHS compliant.
- Halogen-free capacitors are also available.



SPECIFICATIONS

Item	Characteristics													
Rated Voltage Range	160~400 V _{dc}	420~500 V _{dc}												
Operating Temperature Range	-40~+105°C	-25~+105°C												
Capacitance Tolerance	±20%(M) (at 20°C, 120Hz)													
Leakage Current	<table border="1"> <thead> <tr> <th>C · V \ Time</th> <th>After 1 minute</th> <th>After 5 minutes</th> </tr> </thead> <tbody> <tr> <td>≤ 1000</td> <td>I = 0.1CV + 40</td> <td>I = 0.03CV + 15</td> </tr> <tr> <td>> 1000</td> <td>I = 0.04CV + 100</td> <td>I = 0.02CV + 25</td> </tr> </tbody> </table> <p>Where, I: Max. Leakage current(μA) C: Nominal capacitance(μF) V: Rated voltage(V_{dc}) (at 20°C)</p>		C · V \ Time	After 1 minute	After 5 minutes	≤ 1000	I = 0.1CV + 40	I = 0.03CV + 15	> 1000	I = 0.04CV + 100	I = 0.02CV + 25			
C · V \ Time	After 1 minute	After 5 minutes												
≤ 1000	I = 0.1CV + 40	I = 0.03CV + 15												
> 1000	I = 0.04CV + 100	I = 0.02CV + 25												
Dissipation Factor(Tanδ)	<table border="1"> <thead> <tr> <th>Rated Voltage(V_{dc})</th> <th>160~250</th> <th>350~500</th> </tr> </thead> <tbody> <tr> <td>Tanδ(Max.)</td> <td>0.20</td> <td>0.24</td> </tr> </tbody> </table> <p>(at 20°C, 120Hz)</p>		Rated Voltage(V _{dc})	160~250	350~500	Tanδ(Max.)	0.20	0.24						
Rated Voltage(V _{dc})	160~250	350~500												
Tanδ(Max.)	0.20	0.24												
Temperature Characteristics (Max. Impedance ratio)	<table border="1"> <thead> <tr> <th>Rated Voltage(V_{dc})</th> <th>160~250</th> <th>350~400</th> <th>420~500</th> </tr> </thead> <tbody> <tr> <td>Z(-25°C)/Z(20°C)</td> <td>3</td> <td>5</td> <td>6</td> </tr> <tr> <td>Z(-40°C)/Z(20°C)</td> <td>6</td> <td>6</td> <td>-</td> </tr> </tbody> </table> <p>(at 120Hz)</p>		Rated Voltage(V _{dc})	160~250	350~400	420~500	Z(-25°C)/Z(20°C)	3	5	6	Z(-40°C)/Z(20°C)	6	6	-
Rated Voltage(V _{dc})	160~250	350~400	420~500											
Z(-25°C)/Z(20°C)	3	5	6											
Z(-40°C)/Z(20°C)	6	6	-											
Load Life	<p>The following specifications shall be satisfied when the capacitors are restored to 20°C after the rated voltage with the rated ripple current is applied (the peak voltage shall not exceed the rated voltage) for 10,000 hours at 105°C. (where, 7,000 hours for ø 8, 8,000 hours for ø 10)</p> <p>Capacitance change ≤ ±20% of the initial value Tanδ ≤ 200% of the initial specified value Leakage current ≤ The initial specified value</p>													
Shelf Life	<p>The following specifications shall be satisfied when the capacitors are restored to 20°C after exposing them for 1,000 hours at 105°C without voltage applied. The rated voltage shall be applied to the capacitors for a minimum of 30 minutes, at least 24 hours and not more than 48 hours before the measurements.</p> <p>Capacitance change ≤ ±20% of the initial value Tanδ ≤ 200% of the initial specified value Leakage current ≤ 500% of the initial specified value</p>													
Others	Satisfied characteristics KS C IEC 60384-4													

DIMENSIONS OF NFA Series

Unit(mm)

Marking : DARK BROWN SLEEVE, SILVER INK

øD	8	10	12.5	16	18	20	22	25.4
ød	0.6	0.6	0.6	0.8	0.8	0.8	1.0	1.0
F	3.5	5.0	5.0	7.5	7.5	7.5	10.0	10.0
øD'	øD + 0.5 max.							
L'	L + 1.5 max.		L + 2.0 max.					

RATINGS OF NFA Series

V _{dc}	Capacitance (μF)	∅ D×L(mm)	Rated Ripple Current (mA _{rms} /105°C, 120Hz)
160	22	10 × 20	192
	33	10 × 20	236
	47	12.5 × 20	312
	68	12.5 × 25	409
	100	16 × 25	548
	150	16 × 31.5	724
	220	16 × 31.5	876
	330	16 × 35.5	1110
		22 × 25	1130
	390	22 × 30	1310
	470	25.4 × 30	1540
		22 × 35	1650
	560	22 × 40	1730
		22 × 45	1990
	680	25.4 × 35	1950
		22 × 50	2270
820	25.4 × 40	2240	
	25.4 × 50	2670	
200	22	10 × 20	192
	33	10 × 20	236
		12.5 × 20	262
	47	12.5 × 20	312
		10 × 33	409
	68	12.5 × 25	409
		16 × 25	548
	150	12.5 × 35	600
		16 × 31.5	701
	220	12.5 × 45	700
		16 × 31.5	800
		18 × 31.5	906
		22 × 25	730
	330	16 × 45	1100
		22 × 30	1090
	390	22 × 35	1250
		25.4 × 30	1270
	470	22 × 40	1440
		25.4 × 35	1470
	560	22 × 45	1640
		22 × 50	1710
		25.4 × 40	1680
25.4 × 50		2200	

V _{dc}	Capacitance (μF)	∅ D×L(mm)	Rated Ripple Current (mA _{rms} /105°C, 120Hz)
250	10	10 × 20	130
	22	12.5 × 20	214
	33	12.5 × 25	285
	47	12.5 × 25	340
	56	10 × 33	350
	68	16 × 25	452
	100	16 × 31.5	591
	150	18 × 25	700
	180	22 × 25	770
	220	18 × 31.5	850
		22 × 30	910
	270	22 × 35	1060
		25.4 × 30	1080
	330	20 × 40	1196
		22 × 40	1230
		25.4 × 35	1260
390	22 × 45	1400	
	25.4 × 40	1430	
470	22 × 50	1600	
560	25.4 × 50	1860	
350	10	10 × 20	126
	22	12.5 × 20	207
	33	16 × 20	284
	47	16 × 25	364
	68	16 × 31.5	472
	100	18 × 31.5	591
		22 × 25	530
	120	22 × 30	620
	150	18 × 40	760
		25.4 × 30	740
	180	22 × 35	800
	200	22 × 40	880
		25.4 × 35	900
	220	22 × 45	970
	270	22 × 50	1110
		25.4 × 40	1090
330	25.4 × 50	1310	

RATED RIPPLE CURRENT MULTIPLIERS

Frequency Multipliers

Freq.(Hz)	120	1K	10K	50K	100K
Factor	1.00	1.25	1.50	1.60	1.75

RATINGS OF NFA Series

V _{dc}	Capacitance (μF)	∅D×L(mm)	Rated Ripple Current (mA _{rms} /105°C, 120Hz)
400	2.2	8 × 11.5	27
	3.3	8 × 11.5	33
	4.7	8 × 11.5	39
	6.8	8 × 15	63
	8.2	8 × 20	75
	10	10 × 20	126
	15	10 × 20	154
	22	12.5 × 25	225
	33	16 × 20	284
	47	16 × 25	364
	68	16 × 31.5	472
	82	18 × 31.5	536
		22 × 25	490
	100	18 × 35.5	611
	120	18 × 40	680
		22 × 30	630
	150	18 × 40	760
		22 × 35	750
		25.4 × 30	800
	180	20 × 40	855
22 × 40		860	
25.4 × 35		880	
200	22 × 45	940	
220	22 × 45	996	
	22 × 50	1030	
	25.4 × 40	1010	
270	25.4 × 50	1220	
330	25.4 × 50	1260	
420	2.2	8 × 11.5	25
	3.3	8 × 11.5	31
	4.7	8 × 11.5	37
	6.8	8 × 20	76
	8.2	10 × 16	87
	10	10 × 20	116
	15	10 × 25	155
	22	12.5 × 20	191
	33	16 × 20	262
	47	16 × 25	335
	68	18 × 25	435
	82	16 × 31.5	507
		22 × 25	490
	100	18 × 31.5	580
		22 × 30	580
	120	18 × 40	659
		22 × 35	670
		25.4 × 30	680
	150	18 × 45	757
		22 × 40	790
25.4 × 35		800	
180	22 × 45	900	
200	25.4 × 40	970	
220	22 × 50	1030	
270	25.4 × 50	1200	

V _{dc}	Capacitance (μF)	∅D×L(mm)	Rated Ripple Current (mA _{rms} /105°C, 120Hz)
450	2.2	8 × 15	44
	3.3	10 × 16	63
	4.7	10 × 16	74
	6.8	10 × 20	96
	8.2	10 × 20	106
	10	10 × 20	108
		12.5 × 20	114
	22	16 × 25	241
	33	12.5 × 30	315
		16 × 31.5	319
	47	18 × 25	368
	56	16 × 31.5	410
	68	18 × 25	435
		18 × 31.5	473
		22 × 25	440
	82	18 × 35.5	537
	100	18 × 40	602
		22 × 30	570
	120	18 × 40	659
		22 × 35	660
25.4 × 30		670	
150	20 × 40	757	
	22 × 40	780	
	25.4 × 35	790	
180	22 × 45	892	
	25.4 × 40	910	
200	22 × 50	970	
220	25.4 × 50	1090	
500	3.3	10 × 12.5	52
	4.7	10 × 12.5	62
	6.8	10 × 16	83
	8.2	10 × 20	98
	10	12.5 × 20	120
	22	16 × 25	228
	33	18 × 20	230
		18 × 25	260
	47	18 × 31.5	393
	56	18 × 31.5	393
		22 × 25	390
	68	16 × 45	625
		18 × 35.5	550
		22 × 30	460
	82	25.4 × 30	540
	100	22 × 35	590
22 × 40		620	
120	22 × 45	710	
	25.4 × 35	690	
	25.4 × 40	720	
150	22 × 50	827	
180	25.4 × 50	960	

NFL Series

• 105°C 8,000~12,000Hrs assured.

- Non-solvent proof.
- High Ripple, Long Life.
- For ballasts stabilizer and other long life required applications.
- RoHS compliant.
- Halogen-free capacitors are also available.



SPECIFICATIONS

Item	Characteristics													
Rated Voltage Range	160~400 V _{DC}	450~500 V _{DC}												
Operating Temperature Range	-40~+105°C	-25~+105°C												
Capacitance Tolerance	±20%(M) (at 20°C, 120Hz)													
Leakage Current	<table border="1"> <thead> <tr> <th>C · V \ Time</th> <th>After 1 minute</th> <th>After 5 minutes</th> </tr> </thead> <tbody> <tr> <td>≤ 1000</td> <td>I = 0.1CV + 40</td> <td>I = 0.03CV + 15</td> </tr> <tr> <td>> 1000</td> <td>I = 0.04CV + 100</td> <td>I = 0.02CV + 25</td> </tr> </tbody> </table> <p>Where, I: Max. Leakage current(μA) C: Nominal capacitance(μF) V: Rated voltage(V_{DC}) (at 20°C)</p>		C · V \ Time	After 1 minute	After 5 minutes	≤ 1000	I = 0.1CV + 40	I = 0.03CV + 15	> 1000	I = 0.04CV + 100	I = 0.02CV + 25			
C · V \ Time	After 1 minute	After 5 minutes												
≤ 1000	I = 0.1CV + 40	I = 0.03CV + 15												
> 1000	I = 0.04CV + 100	I = 0.02CV + 25												
Dissipation Factor(Tanδ)	<table border="1"> <thead> <tr> <th>Rated Voltage(V_{DC})</th> <th>160~250</th> <th>350~500</th> </tr> </thead> <tbody> <tr> <td>Tanδ(Max.)</td> <td>0.20</td> <td>0.24</td> </tr> </tbody> </table> <p>(at 20°C, 120Hz)</p>		Rated Voltage(V _{DC})	160~250	350~500	Tanδ(Max.)	0.20	0.24						
Rated Voltage(V _{DC})	160~250	350~500												
Tanδ(Max.)	0.20	0.24												
Temperature Characteristics (Max. Impedance ratio)	<table border="1"> <thead> <tr> <th>Rated Voltage(V_{DC})</th> <th>160~250</th> <th>350~400</th> <th>450~500</th> </tr> </thead> <tbody> <tr> <td>Z(-25°C)/Z(20°C)</td> <td>3</td> <td>5</td> <td>6</td> </tr> <tr> <td>Z(-40°C)/Z(20°C)</td> <td>6</td> <td>6</td> <td>-</td> </tr> </tbody> </table> <p>(at 120Hz)</p>		Rated Voltage(V _{DC})	160~250	350~400	450~500	Z(-25°C)/Z(20°C)	3	5	6	Z(-40°C)/Z(20°C)	6	6	-
Rated Voltage(V _{DC})	160~250	350~400	450~500											
Z(-25°C)/Z(20°C)	3	5	6											
Z(-40°C)/Z(20°C)	6	6	-											
Load Life	<p>The following specifications shall be satisfied when the capacitors are restored to 20°C after the rated voltage with the rated ripple current is applied (the peak voltage shall not exceed the rated voltage) for 12,000 hours at 105°C. (where, 8,000 hours for ø8, 10,000 hours for ø10, ø8x50L)</p> <p>Capacitance change ≤ ±20% of the initial value Tanδ ≤ 200% of the initial specified value Leakage current ≤ The initial specified value</p>													
Shelf Life	<p>The following specifications shall be satisfied when the capacitors are restored to 20°C after exposing them for 1,000 hours at 105°C without voltage applied. The rated voltage shall be applied to the capacitors for a minimum of 30 minutes, at least 24 hours and not more than 48 hours before the measurements.</p> <p>Capacitance change ≤ ±20% of the initial value Tanδ ≤ 200% of the initial specified value Leakage current ≤ 500% of the initial specified value</p>													
Others	Satisfied characteristics KS C IEC 60384-4													

DIMENSIONS OF NFL Series

Unit(mm)

Marking : DARK BROWN SLEEVE, SILVER INK

øD	8	10	12.5	16	18	20
ød	0.6	0.6	0.6	0.8	0.8	0.8
F	3.5	5.0	5.0	7.5	7.5	7.5
øD'	øD + 0.5 max.					
L'	L + 2.0 max.					

※ ø8 x 11.5~20L, L' ≤ L+1.5

RATINGS OF NFL Series

Vdc		160		200	
Items μF	ø D × L (mm)	Rated Ripple Current (mArms/105°C, 120Hz)		ø D × L (mm)	Rated Ripple Current (mArms/105°C, 120Hz)
		27			
39	10 × 16	237		10 × 20	256
47	10 × 20	280		12.5 × 20	312
56	10 × 25	335		12.5 × 25	371
68	12.5 × 20	375		12.5 × 25	409
100	10 × 45	562		10 × 50	591
	12.5 × 25	496		16 × 25	550
150	16 × 31.5	724		12.5 × 50	786
				16 × 25	671
220	12.5 × 50	952		18 × 31.5	905
	16 × 31.5	876			
270	16 × 35.5	992		18 × 35.5	1,036
330	16 × 40	1,132		18 × 40	1,164
	18 × 31.5	1,109			
390	18 × 35.5	1,246			
470	18 × 40	1,389			

Vdc		250		350	
Items μF	ø D × L (mm)	Rated Ripple Current (mArms/105°C, 120Hz)		ø D × L (mm)	Rated Ripple Current (mArms/105°C, 120Hz)
		10	10 × 16		
22	10 × 20	192		12.5 × 20	213
33	10 × 25	257		8 × 50	245
				12.5 × 25	285
39	10 × 30	290		10 × 40	340
47	8 × 50	250		10 × 50	405
	12.5 × 20	312		16 × 25	375
68	10 × 40	450		16 × 31.5	503
	12.5 × 30	441		18 × 25	488
82	10 × 50	536		12.5 × 45	571
100	10 × 50	585		18 × 31.5	610
	16 × 25	548			
150	18 × 25	748			
180	12.5 × 50	800			
220	18 × 31.5	905			

Vdc		400		450	
Items μF	ø D × L (mm)	Rated Ripple Current (mArms/105°C, 120Hz)		ø D × L (mm)	Rated Ripple Current (mArms/105°C, 120Hz)
		3.3	8 × 11.5		
4.7	8 × 15	42		10 × 16	70
6.8	8 × 20	59		10 × 20	90
10	10 × 20	110		12.5 × 20	120
22	12.5 × 20	208		8 × 50	230
				16 × 25	228
27	8 × 50	154			
33	16 × 20	261		16 × 31.5	270
39	10 × 45	340		10 × 50	305
47	16 × 25	335		18 × 31.5	360
68	12.5 × 45	482		12.5 × 50	473
	16 × 31.5	460		18 × 35.5	500
82	12.5 × 50	527		18 × 35.5	549
	18 × 31.5	520			
100	18 × 35.5	630		12.5 × 60	626
				18 × 35.5	660
				18 × 40	670
120	18 × 40	700		20 × 40	720

RATINGS OF NFL Series

Vdc	500	
μF \ Items	$\varnothing D \times L$ (mm)	Rated Ripple Current (mArms/105°C,120Hz)
10	12.5×20	150
22	16×25	228
27	10×50	253
33	16×31.5	270
	18×25	260
39	12.5×50	358
47	18×31.5	360
60	12.5×60	467
68	18×35.5	500
82	18×40	606
100	20×40	657

RATED RIPPLE CURRENT MULTIPLIERS

Frequency Multipliers

Freq.(Hz)	120	1k	10k	50k	100k
Factor	1.00	1.25	1.50	1.60	1.75

NFR Series

• 105°C 8,000~12,000Hrs assured.

- Non-solvent proof.
- High Ripple, Long Life.
- For Ballasts stabilizer and other long life required applications.
- RoHS compliant.
- Halogen-free capacitors are also available.

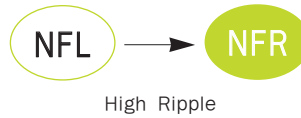

SPECIFICATIONS

Item	Characteristics													
Rated Voltage Range	160~400 V _{DC}	420~500 V _{DC}												
Operating Temperature Range	-40~+105°C	-25~+105°C												
Capacitance Tolerance	±20%(M) (at 20°C, 120Hz)													
Leakage Current	<table border="1"> <thead> <tr> <th>C · V</th> <th>Time</th> <th>After 1 minute</th> <th>After 5 minutes</th> </tr> </thead> <tbody> <tr> <td>≤ 1000</td> <td></td> <td>I = 0.1CV + 40</td> <td>I = 0.03CV + 15</td> </tr> <tr> <td>> 1000</td> <td></td> <td>I = 0.04CV + 100</td> <td>I = 0.02CV + 25</td> </tr> </tbody> </table> <p>Where, I:Max. Leakage current(μA) C:Nominal capacitance(μF) V:Rated voltage(V_{DC}) (at 20°C)</p>		C · V	Time	After 1 minute	After 5 minutes	≤ 1000		I = 0.1CV + 40	I = 0.03CV + 15	> 1000		I = 0.04CV + 100	I = 0.02CV + 25
C · V	Time	After 1 minute	After 5 minutes											
≤ 1000		I = 0.1CV + 40	I = 0.03CV + 15											
> 1000		I = 0.04CV + 100	I = 0.02CV + 25											
Dissipation Factor(Tanδ)	<table border="1"> <thead> <tr> <th>Rated Voltage(V_{DC})</th> <th>160~250</th> <th>350~500</th> </tr> </thead> <tbody> <tr> <td>Tanδ(Max.)</td> <td>0.20</td> <td>0.24</td> </tr> </tbody> </table> <p>(at 20°C, 120Hz)</p>		Rated Voltage(V _{DC})	160~250	350~500	Tanδ(Max.)	0.20	0.24						
Rated Voltage(V _{DC})	160~250	350~500												
Tanδ(Max.)	0.20	0.24												
Temperature Characteristics (Max. Impedance ratio)	<table border="1"> <thead> <tr> <th>Rated Voltage(V_{DC})</th> <th>160~250</th> <th>350~400</th> <th>420~500</th> </tr> </thead> <tbody> <tr> <td>Z(-25°C)/Z(20°C)</td> <td>3</td> <td>5</td> <td>6</td> </tr> <tr> <td>Z(-40°C)/Z(20°C)</td> <td>6</td> <td>6</td> <td>-</td> </tr> </tbody> </table> <p>(at 120Hz)</p>		Rated Voltage(V _{DC})	160~250	350~400	420~500	Z(-25°C)/Z(20°C)	3	5	6	Z(-40°C)/Z(20°C)	6	6	-
Rated Voltage(V _{DC})	160~250	350~400	420~500											
Z(-25°C)/Z(20°C)	3	5	6											
Z(-40°C)/Z(20°C)	6	6	-											
Load Life	<p>The following specifications shall be satisfied when the capacitors are restored to 20°C after the rated voltage with the rated ripple current is applied (the peak voltage shall not exceed the rated voltage) for 12,000 hours at 105°C. (where, 8,000 hours for ø8, 10,000 hours for ø10, ø8x50L)</p> <p>Capacitance change ≤ ±20% of the initial value Tanδ ≤ 200% of the initial specified value Leakage current ≤ The initial specified value</p>													
Shelf Life	<p>The following specifications shall be satisfied when the capacitors are restored to 20°C after exposing them for 1,000 hours at 105°C without voltage applied. The rated voltage shall be applied to the capacitors for a minimum of 30 minutes, at least 24 hours and not more than 48 hours before the measurements.</p> <p>Capacitance change ≤ ±20% of the initial value Tanδ ≤ 200% of the initial specified value Leakage current ≤ 500% of the initial specified value</p>													
Others	Satisfied characteristics KS C IEC 60384-4													

DIMENSIONS OF NFR Series

Unit(mm)

Marking : DARK BROWN SLEEVE, SILVER INK

øD	8	10	12.5	16	18	20
ød	0.6	0.6	0.6	0.8	0.8	0.8
F	3.5	5.0	5.0	7.5	7.5	7.5
øD'	øD + 0.5 max.					
L'	L + 2.0 max.					

※ ø8 × 11.5~20L, L' ≤ L + 1.5

RATINGS OF NFR Series

V _{dc}		160		200	
μF	Items	$\varnothing D \times L(\text{mm})$	Rated Ripple Current (mArms/105°C, 100kHz)	$\varnothing D \times L(\text{mm})$	Rated Ripple Current (mArms/105°C, 100kHz)
10		10 × 16	320	10 × 16	320
22		10 × 16	450	10 × 16	450
25		10 × 16	478	8 × 20	465
				10 × 16	478
27		10 × 16	500	10 × 16	500
33		10 × 16	600	10 × 20	650
39		10 × 16	613	10 × 20	670
47		10 × 20	750	12.5 × 20	850
56		10 × 20	788	12.5 × 25	1,013
68		10 × 20	900	10 × 33	1,200
		12.5 × 20	950	12.5 × 25	1,070
82		12.5 × 25	1,025	16 × 20	1,250
100		12.5 × 25	1,125	16 × 25	1,300
		16 × 20	1,125		
120		16 × 25	1,339	16 × 25	1,339
150		16 × 25	1,510	16 × 25	1,510
220		16 × 31.5	1,933	18 × 31.5	2,030
		18 × 25	1,870		
270		16 × 35.5	2,189	18 × 35.5	2,300
330		16 × 40	2,516	18 × 40	2,586
		18 × 31.5	2,446		
390		18 × 35.5	2,745		
470		18 × 40	3,064		

V _{dc}		250		350	
μF	Items	$\varnothing D \times L(\text{mm})$	Rated Ripple Current (mArms/105°C, 100kHz)	$\varnothing D \times L(\text{mm})$	Rated Ripple Current (mArms/105°C, 100kHz)
4.7		8 × 11.5	160		
6.8		8 × 11.5	180		
		10 × 12.5	250		
10		8 × 15	240	8 × 20	350
		10 × 16	350	10 × 16	330
22		10 × 16	470	12.5 × 20	650
		10 × 20	500		
33		12.5 × 16	613	10 × 33	700
				12.5 × 25	750
		12.5 × 20	688	16 × 20	750
47		8 × 50	875	10 × 50	950
		12.5 × 20	850	16 × 20	950
68		10 × 40	1,125	16 × 31.5	1,300
		12.5 × 25	1,070	18 × 25	1,300
82		12.5 × 30	1,340	18 × 25	1,400
		16 × 20	1,340		
100		16 × 25	1,400	18 × 31.5	1,550
		18 × 20	1,400		
120		18 × 20	1,450		
150		18 × 25	1,740		
180		12.5 × 50	1,910		
		18 × 31.5	1,960		
220		18 × 31.5	2,040		

RATINGS OF NFR Series

V _{dc}		400		420	
Items	μF	∅ D × L (mm)	Rated Ripple Current (mA _{rms} /105°C, 100kHz)	∅ D × L (mm)	Rated Ripple Current (mA _{rms} /105°C, 100kHz)
1		8 × 11.5	60		
2.2		8 × 11.5	100		
3.3		8 × 11.5	130		
		10 × 12.5	150		
4.7		8 × 11.5	145		
		10 × 12.5	170		
6.8		8 × 15	180		
		10 × 16	280		
10		8 × 20	350	10 × 20	360
		10 × 16	350		
15		10 × 20	410	12.5 × 20	450
		12.5 × 16	410		
22		10 × 25	500	12.5 × 25	580
		12.5 × 20	550	16 × 20	725
33		12.5 × 25	780	12.5 × 30	750
		16 × 20	800	16 × 25	920
47		16 × 25	980	12.5 × 40	920
		18 × 20	980	16 × 25	980
56				18 × 20	950
68		18 × 25	1,350	18 × 25	1,100
82		18 × 31.5	1,500	18 × 31.5	1,300
100		18 × 35.5	1,650	18 × 35.5	1,400
120		18 × 40	1,850	18 × 35.5	1,600
				18 × 40	1,750
150		18 × 45	1,900		
180		18 × 45	2,000		

V _{dc}		450		500	
Items	μF	∅ D × L (mm)	Rated Ripple Current (mA _{rms} /105°C, 100kHz)	∅ D × L (mm)	Rated Ripple Current (mA _{rms} /105°C, 100kHz)
4.7		8 × 20	220		
		10 × 16	220		
6.8		10 × 16	250		
		10 × 20	280		
10		10 × 20	360	12.5 × 20	440
		10 × 20	400	12.5 × 25	500
15		12.5 × 20	450	16 × 20	500
		12.5 × 25	580	12.5 × 30	600
22		16 × 20	725	16 × 25	600
				18 × 20	600
33		12.5 × 30	750	16 × 31.5	700
		16 × 25	920	18 × 25	700
40				12.5 × 50	860
47		10 × 50	900	18 × 31.5	880
		12.5 × 40	920		
		16 × 25	980		
60			12.5 × 60	1,180	
68		18 × 25	1,100	18 × 35.5	1,200
82		18 × 31.5	1,300	18 × 40	1,300
100		18 × 35.5	1,400	18 × 45	1,500
				20 × 40	1,500
120		18 × 40	1,650		
150		18 × 45	1,800		
		20 × 40	1,800		

RATED RIPPLE CURRENT MULTIPLIERS

Frequency Multipliers

Cap. (μF)	120	1k	10k	50k	100k
1 ~ 15	0.35	0.65	0.90	0.95	1.00
22 ~ 82	0.40	0.70	0.90	0.95	1.00
100 ~ 470	0.45	0.75	0.90	0.95	1.00

NBC Series

• 105°C 5,000~12,000Hrs assured.

- Non-solvent proof
- High Ripple, Long Life, Low Temp.
- For SMPS, IP-Board, Adaptor, LED Lighting
- RoHS compliant.
- Halogen-free capacitors are also available.
- AEC-Q200 compliant : Please contact us for more details, test data, information.

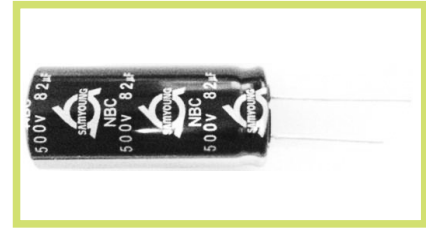
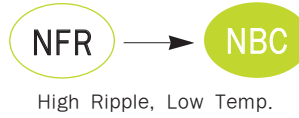

SPECIFICATIONS

Item	Characteristics												
Rated Voltage Range	160~500 V _{DC}												
Operating Temperature Range	-40~+105°C												
Capacitance Tolerance	±20%(M) (at 20°C, 120Hz)												
Leakage Current	<table border="1"> <thead> <tr> <th>C · V</th> <th>Time</th> <th>After 1 minute</th> <th>After 5 minutes</th> </tr> </thead> <tbody> <tr> <td>≤ 1000</td> <td></td> <td>I = 0.1CV + 40</td> <td>I = 0.03CV + 15</td> </tr> <tr> <td>> 1000</td> <td></td> <td>I = 0.04CV + 100</td> <td>I = 0.02CV + 25</td> </tr> </tbody> </table> <p>Where, I:Max. Leakage current(µA) C:Nominal capacitance(µF) V:Rated voltage(V_{DC}) (at 20°C)</p>	C · V	Time	After 1 minute	After 5 minutes	≤ 1000		I = 0.1CV + 40	I = 0.03CV + 15	> 1000		I = 0.04CV + 100	I = 0.02CV + 25
C · V	Time	After 1 minute	After 5 minutes										
≤ 1000		I = 0.1CV + 40	I = 0.03CV + 15										
> 1000		I = 0.04CV + 100	I = 0.02CV + 25										
Dissipation Factor(Tanδ)	<table border="1"> <thead> <tr> <th>Rated Voltage(V_{DC})</th> <th>160~250</th> <th>350~500</th> </tr> </thead> <tbody> <tr> <td>Tanδ(Max.)</td> <td>0.20</td> <td>0.24</td> </tr> </tbody> </table> <p>(at 20°C, 120Hz)</p>	Rated Voltage(V _{DC})	160~250	350~500	Tanδ(Max.)	0.20	0.24						
Rated Voltage(V _{DC})	160~250	350~500											
Tanδ(Max.)	0.20	0.24											
Temperature Characteristics (Max. Impedance ratio)	<table border="1"> <thead> <tr> <th>Rated Voltage(V_{DC})</th> <th>160~500</th> </tr> </thead> <tbody> <tr> <td>Z(-25°C)/Z(20°C)</td> <td>3</td> </tr> <tr> <td>Z(-40°C)/Z(20°C)</td> <td>6</td> </tr> </tbody> </table> <p>(at 120Hz)</p>	Rated Voltage(V _{DC})	160~500	Z(-25°C)/Z(20°C)	3	Z(-40°C)/Z(20°C)	6						
Rated Voltage(V _{DC})	160~500												
Z(-25°C)/Z(20°C)	3												
Z(-40°C)/Z(20°C)	6												
Load Life	<p>The following specifications shall be satisfied when the capacitors are restored to 20°C after the rated voltage with the rated ripple current is applied (the peak voltage shall not exceed the rated voltage) for 12,000 hours at 105°C. (where 5,000 hours for ø6.3, 8,000 hours for ø8, 10,000 hours for ø10)</p> <p>Capacitance change ≤ ±20 % of the initial value Tanδ ≤ 200 % of the initial specified value Leakage current ≤ The initial specified value</p>												
Shelf Life	<p>The following specifications shall be satisfied when the capacitors are restored to 20°C after exposing them for 1,000 hours at 105°C without voltage applied. The rated voltage shall be applied to the capacitors for a minimum of 30 minutes, at least 24 hours and not more than 48 hours before the measurements.</p> <p>Capacitance change ≤ ±20 % of the initial value Tanδ ≤ 200 % of the initial specified value Leakage current ≤ 500 % of the initial specified value</p>												
Others	Satisfied characteristics KS C IEC 60384-4												

DIMENSIONS OF NBC Series

Unit(mm)

Marking : DARK BLUE SLEEVE, SILVER INK

øD	6.3	8	10	12.5	16	18	20	22	25.4
ød	0.5	0.6	0.6	0.6	0.8	0.8	0.8	1.0	1.0
F	2.5	3.5	5.0	5.0	7.5	7.5	7.5	10.0	10.0
øD'	øD + 0.5 max.								
L'	L + 1.5 max.		L + 2.0 max.						

※ ø10 x 12L, L' ≤ L + 1.5

RATINGS OF NBC Series

V _{dc}	Capacitance (μF)	∅ D×L(mm)	Rated Ripple Current (mA _{rms} /105°C, 120Hz)
160	6.8	8 × 11.5	90
	8.2	5 × 15	85
	10	6.3 × 15	106
		8 × 15	121
	15	8 × 15	148
		10 × 12	221
	22	10 × 12.5	221
		10 × 16	243
		10 × 12	240
	27	10 × 12.5	240
		10 × 16	264
		10 × 16	270
	33	10 × 16	270
	39	10 × 16	292
	47	10 × 20	369
	68	10 × 20	400
	82	10 × 25	455
		12.5 × 20	495
	100	12.5 × 20	561
	120	10 × 33	638
		12.5 × 25	638
	150	16 × 25	825
	180	16 × 25	891
	220	16 × 31.5	968
		18 × 25	968
	270	16 × 35.5	1100
	330	16 × 40	1256
		18 × 31.5	1231
		22 × 25	1200
	390	22 × 30	1380
470	18 × 40	1541	
	25.4 × 30	1630	
560	22 × 35	1750	
	22 × 40	1830	
680	22 × 45	2110	
	25.4 × 35	2060	
820	22 × 50	2400	
	25.4 × 40	2370	
1000	25.4 × 50	2830	
200	4.7	8 × 11.5	77
	8.2	6.3 × 15	101
	10	8 × 11.5	113
		8 × 20	140
	15	8 × 15	148
	22	10 × 12	221
		10 × 12.5	221
		10 × 16	243
	27	10 × 16	264
	33	10 × 20	308
	39	10 × 20	336
	47	10 × 20	369
		12.5 × 20	440
	68	12.5 × 20	492
		12.5 × 25	594
	82	12.5 × 25	616
		16 × 20	616
	100	12.5 × 30	700
		16 × 25	717
	120	12.5 × 35	815
		16 × 25	785
	150	16 × 25	836
	180	16 × 31.5	935
	220	18 × 31.5	1100
		22 × 25	1100
	270	18 × 35.5	1265
		22 × 30	1070
	330	18 × 40	1375
		22 × 35	1360
	390	25.4 × 30	1380
22 × 40		1570	
470	25.4 × 35	1600	
	22 × 45	1780	
560	22 × 50	1850	
	25.4 × 40	1830	
	25.4 × 50	2390	

V _{dc}	Capacitance (μF)	∅ D×L(mm)	Rated Ripple Current (mA _{rms} /105°C, 120Hz)
250	4.7	8 × 15	80
	6.8	8 × 20	106
		10 × 12	119
		10 × 12.5	119
	10	10 × 12	160
		10 × 12.5	160
	15	10 × 12	174
		10 × 12.5	174
	22	10 × 16	230
	27	10 × 20	270
	33	12.5 × 20	323
	39	12.5 × 20	354
	47	12.5 × 20	440
	68	12.5 × 25	594
	82	12.5 × 30	660
	100	16 × 25	717
	120	16 × 25	785
	150	18 × 25	902
	180	18 × 31.5	1012
		22 × 25	900
	220	18 × 31.5	1100
		22 × 30	1060
	270	22 × 35	1240
		25.4 × 30	1260
	330	22 × 40	1440
		25.4 × 35	1460
	390	22 × 45	1620
		25.4 × 40	1660
	470	22 × 50	1860
	560	25.4 × 50	2160
350	4.7	8 × 11.5	93
	6.8	8 × 15	101
	10	10 × 12	153
		10 × 12.5	153
	15	10 × 16	158
		10 × 20	197
	22	12.5 × 20	297
	27	12.5 × 20	314
	33	12.5 × 20	319
	39	12.5 × 25	352
	47	12.5 × 30	451
	68	16 × 25	605
	82	18 × 25	688
	100	18 × 31.5	817
		22 × 25	800
	120	18 × 35.5	924
		22 × 30	930
	150	18 × 35.5	1036
		25.4 × 30	1110
	180	18 × 40	1155
		22 × 35	1200
	200	22 × 40	1330
		25.4 × 35	1350
	220	22 × 45	1450
	270	22 × 50	1670
		25.4 × 40	1650
	330	25.4 × 50	1970

RATED RIPPLE CURRENT MULTIPLIERS

Frequency Multipliers

Freq.(Hz) Cap.(μF)	120	1K	10K	50K	100K
1 ~ 82	1.00	1.75	2.25	2.35	2.50
100 ~ 1000	1.00	1.67	2.05	2.15	2.25

RATINGS OF NBC Series

V _{DC}	Capacitance (μF)	∅ D × L (mm)	Rated Ripple Current (mA _{rms} /105°C, 120Hz)
400	1	6.3 × 11	22
	1.5	6.3 × 15	32
		8 × 11.5	34
	2.2	8 × 11.5	41
	3.3	8 × 11.5	50
	4.7	8 × 11.5	60
	6.8	8 × 15	94
	8.2	8 × 20	119
		10 × 12	132
		10 × 12.5	132
	10	10 × 16	145
	22	12.5 × 20	297
	27	12.5 × 20	314
	33	12.5 × 25	343
	39	12.5 × 25	352
		12.5 × 30	378
	47	12.5 × 35	462
		16 × 25	480
	68	12.5 × 40	550
		18 × 25	627
	82	18 × 25	770
		18 × 31.5	770
		22 × 25	710
	100	18 × 31.5	817
		18 × 35.5	875
	120	18 × 35.5	924
		18 × 40	1003
		22 × 30	910
	150	18 × 40	1122
		22 × 35	1100
		25.4 × 30	1150
	180	18 × 45	1188
		20 × 40	1188
22 × 40		1230	
200	25.4 × 35	1250	
	22 × 45	1360	
220	22 × 50	1480	
	25.4 × 40	1460	
270	25.4 × 50	1750	
330	25.4 × 50	1810	
420	1	6.3 × 11	17
	1.5	6.3 × 15	24
		8 × 11.5	26
	2.2	8 × 11.5	30
	3.3	8 × 11.5	37
	4.7	8 × 11.5	44
	6.8	8 × 20	105
	8.2	10 × 16	113
	10	10 × 20	135
	22	12.5 × 20	225
	27	12.5 × 20	254
	33	12.5 × 30	340
		16 × 20	345
	39	12.5 × 35	380
		16 × 25	400
	47	12.5 × 40	450
		16 × 25	450
	68	18 × 25	520
		18 × 31.5	580
	82	18 × 25	600
		18 × 31.5	650
		22 × 25	630
	100	16 × 45	770
		18 × 35.5	770
		22 × 30	740
	120	16 × 50	850
		18 × 40	850
		22 × 35	860
	150	25.4 × 30	870
		18 × 45	1000
		20 × 40	1000
		22 × 40	1000
	180	25.4 × 35	1020
22 × 45		1150	
200	25.4 × 40	1240	
220	22 × 50	1320	
270	25.4 × 50	1560	

V _{DC}	Capacitance (μF)	∅ D × L (mm)	Rated Ripple Current (mA _{rms} /105°C, 120Hz)
450	1	6.3 × 11	17
	1.5	6.3 × 15	24
		8 × 11.5	26
	2.2	8 × 15	33
	3.3	8 × 11.5	37
	4.7	10 × 12	76
		10 × 12.5	76
	6.8	8 × 20	105
	8.2	10 × 16	113
	10	10 × 20	135
	22	12.5 × 25	250
	27	12.5 × 25	265
	33	12.5 × 30	340
		16 × 20	345
	39	12.5 × 35	380
		16 × 25	400
	47	12.5 × 40	450
		16 × 25	450
	56	16 × 31.5	520
	68	18 × 25	560
		18 × 31.5	590
		22 × 25	560
	82	16 × 40	650
		18 × 31.5	650
	100	22 × 30	660
		16 × 45	770
		18 × 35.5	770
	120	25.4 × 30	780
		16 × 50	850
		18 × 40	850
		22 × 35	850
	150	22 × 40	880
		25.4 × 35	900
22 × 45		1030	
180	25.4 × 40	1050	
	22 × 50	1170	
220	25.4 × 50	1380	
500	3.3	10 × 12	63
		10 × 12.5	63
	4.7	10 × 12	75
		10 × 12.5	75
	6.8	10 × 16	110
	8.2	10 × 20	141
	10	12.5 × 20	165
	22	12.5 × 30	260
	27	12.5 × 40	329
	33	12.5 × 45	370
		16 × 25	350
	39	12.5 × 50	420
		16 × 31.5	413
	47	16 × 35.5	462
		18 × 31.5	468
	56	22 × 25	510
	68	16 × 45	630
		18 × 35.5	600
		22 × 30	600
	82	16 × 50	685
		18 × 40	670
		25.4 × 30	700
	100	18 × 45	800
		20 × 40	800
		22 × 35	800
		22 × 40	800
	120	18 × 50	920
		22 × 45	920
		25.4 × 35	900
	150	25.4 × 40	940
		22 × 50	980
	180	25.4 × 50	1250

NBF Series

• 105°C 12,000Hrs assured.

- Non-solvent proof
- High Ripple, Long Life, Low Temp.
- Suitable to fit for automotive equipment
- RoHS compliant.
- Halogen-free capacitors are also available.

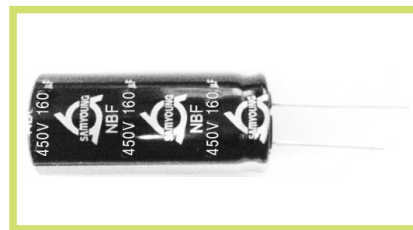
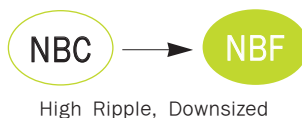

SPECIFICATIONS

Item	Characteristics												
Rated Voltage Range	450~500												
Operating Temperature Range	-40 ~ +105°C												
Capacitance Tolerance	±20%(M) (at 20°C, 120Hz)												
Leakage Current	<table border="1"> <thead> <tr> <th>C · V</th> <th>Time</th> <th>After 1 minute</th> <th>After 5 minutes</th> </tr> </thead> <tbody> <tr> <td>≤ 1000</td> <td></td> <td>I = 0.1CV + 40</td> <td>I = 0.03CV + 15</td> </tr> <tr> <td>> 1000</td> <td></td> <td>I = 0.04CV + 100</td> <td>I = 0.02CV + 25</td> </tr> </tbody> </table> <p>Where, I:Max. Leakage current(µA) C:Nominal capacitance(µF) V:Rated voltage(V_{DC}) (at 20°C)</p>	C · V	Time	After 1 minute	After 5 minutes	≤ 1000		I = 0.1CV + 40	I = 0.03CV + 15	> 1000		I = 0.04CV + 100	I = 0.02CV + 25
C · V	Time	After 1 minute	After 5 minutes										
≤ 1000		I = 0.1CV + 40	I = 0.03CV + 15										
> 1000		I = 0.04CV + 100	I = 0.02CV + 25										
Dissipation Factor(Tanδ)	<table border="1"> <thead> <tr> <th>Rated Voltage(V_{DC})</th> <th>450~500</th> </tr> </thead> <tbody> <tr> <td>Tanδ(Max.)</td> <td>0.24</td> </tr> </tbody> </table> <p>(at 20°C, 120Hz)</p>	Rated Voltage(V _{DC})	450~500	Tanδ(Max.)	0.24								
Rated Voltage(V _{DC})	450~500												
Tanδ(Max.)	0.24												
Temperature Characteristics (Max. Impedance ratio)	<table border="1"> <thead> <tr> <th>Rated Voltage(V_{DC})</th> <th>450~500</th> </tr> </thead> <tbody> <tr> <td>Z(-25°C)/Z(20°C)</td> <td>3</td> </tr> <tr> <td>Z(-40°C)/Z(20°C)</td> <td>6</td> </tr> </tbody> </table> <p>(at 120Hz)</p>	Rated Voltage(V _{DC})	450~500	Z(-25°C)/Z(20°C)	3	Z(-40°C)/Z(20°C)	6						
Rated Voltage(V _{DC})	450~500												
Z(-25°C)/Z(20°C)	3												
Z(-40°C)/Z(20°C)	6												
Load Life	<p>The following specification shall be satisfied when the capacitors are restored to 20°C after the rated voltage with the rated ripple current is applied (the peak voltage shall not exceed the rated voltage) for 12,000 hours at 105°C.</p> <p>Capacitance change ≤ ±20 % of the initial value Tanδ ≤ 200 % of the initial specified value Leakage current ≤ Capacitancechange</p>												
Shelf Life	<p>The following specifications shall be satisfied when the capacitors are restored to 20°C after exposing then for 1,000 hours at 105°C without voltage applied. The rated voltage shall be applied to the capacitors for a minimum of 30 minutes, at least 24 hours and not more than 48 hours before the measurements.</p> <p>Capacitance change ≤ ±20 % of the initial value Tanδ ≤ 200 % of the initial specified value Leakage current ≤ 500 % of the initial specified value</p>												
Others	Satisfied characteristics KS C IEC 60384-4												

DIMENSIONS OF NBF Series

Unit(mm)

Marking : BLACK SLEEVE, WHITE INK

øD	16	18
ød	0.8	0.8
F	7.5	7.5
øD'	øD + 0.5 max.	
L'	L + 2.0 max.	

RATINGS OF NBF Series

V _{dc}	Capacitance (μF)	∅ D×L(mm)	Rated Ripple Current (mA rms/105°C, 120min)
450	47	16 × 20	400
	62	16 × 25	510
		18 × 20	510
	82	16 × 31.5	650
		18 × 25	640
	100	16 × 35.5	750
	110	18 × 31.5	800
	120	16 × 45	860
	130	18 × 35.5	920
	160	18 × 40	980
180	18 × 45	1020	
500	33	16 × 20	340
	39	16 × 25	390
	52	16 × 31.5	490
		18 × 25	480
	82	16 × 45	710
		18 × 31.5	660
		18 × 35.5	690
	100	16 × 50	810
		18 × 40	790

RATED RIPPLE CURRENT MULTIPLIERS

Frequency Multipliers

Cap.(μF) \ Freq.(Hz)	120	1k	10k	50k	100k
1~82	1.00	1.75	2.25	2.35	2.50
100~1000	1.00	1.67	2.05	2.15	2.25

NBD Series

• 105°C 10,000~12,000Hrs assured.

- Non-solvent proof
- High Ripple, Long Life, Low Temp.
- For SMPS, IP-Board, Adaptor, LED Lighting
- RoHS compliant.
- Halogen-free capacitors are also available.

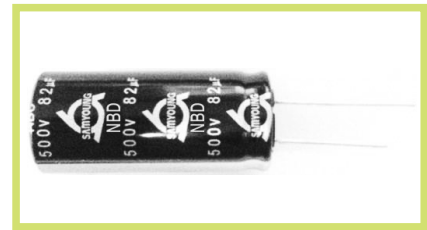
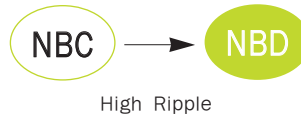

SPECIFICATIONS

Item	Characteristics												
Rated Voltage Range	160~500 V _{DC}												
Operating Temperature Range	-40~ +105°C												
Capacitance Tolerance	±20%(M) (at 20°C, 120Hz)												
Leakage Current	<table border="1"> <thead> <tr> <th>C · V</th> <th>Time</th> <th>After 1 minute</th> <th>After 5 minutes</th> </tr> </thead> <tbody> <tr> <td>≤ 1000</td> <td></td> <td>I = 0.1CV + 40</td> <td>I = 0.03CV + 15</td> </tr> <tr> <td>> 1000</td> <td></td> <td>I = 0.04CV + 100</td> <td>I = 0.02CV + 25</td> </tr> </tbody> </table> <p>Where, I:Max. Leakage current(μA) C:Nominal capacitance(μF) V:Rated voltage(V_{DC}) (at 20°C)</p>	C · V	Time	After 1 minute	After 5 minutes	≤ 1000		I = 0.1CV + 40	I = 0.03CV + 15	> 1000		I = 0.04CV + 100	I = 0.02CV + 25
C · V	Time	After 1 minute	After 5 minutes										
≤ 1000		I = 0.1CV + 40	I = 0.03CV + 15										
> 1000		I = 0.04CV + 100	I = 0.02CV + 25										
Dissipation Factor(Tanδ)	<table border="1"> <thead> <tr> <th>Rated Voltage(V_{DC})</th> <th>160~250</th> <th>350~500</th> </tr> </thead> <tbody> <tr> <td>Tanδ(Max.)</td> <td>0.20</td> <td>0.24</td> </tr> </tbody> </table> <p>(at 20°C, 120Hz)</p>	Rated Voltage(V _{DC})	160~250	350~500	Tanδ(Max.)	0.20	0.24						
Rated Voltage(V _{DC})	160~250	350~500											
Tanδ(Max.)	0.20	0.24											
Temperature Characteristics (Max. Impedance ratio)	<table border="1"> <thead> <tr> <th>Rated Voltage(V_{DC})</th> <th>160~500</th> </tr> </thead> <tbody> <tr> <td>Z(-25°C)/Z(20°C)</td> <td>3</td> </tr> <tr> <td>Z(-40°C)/Z(20°C)</td> <td>6</td> </tr> </tbody> </table> <p>(at 120Hz)</p>	Rated Voltage(V _{DC})	160~500	Z(-25°C)/Z(20°C)	3	Z(-40°C)/Z(20°C)	6						
Rated Voltage(V _{DC})	160~500												
Z(-25°C)/Z(20°C)	3												
Z(-40°C)/Z(20°C)	6												
Load Life	<p>The following specifications shall be satisfied when the capacitors are restored to 20°C after the rated voltage with the rated ripple current is applied (the peak voltage shall not exceed the rated voltage) for 12,000 hours at 105°C. (where 10,000 hours for ϕ10)</p> <p>Capacitance change ≤ ±20 % of the initial value Tanδ ≤ 200 % of the initial specified value Leakage current ≤ The initial specified value</p>												
Shelf Life	<p>The following specifications shall be satisfied when the capacitors are restored to 20°C after exposing them for 1,000 hours at 105°C without voltage applied. The rated voltage shall be applied to the capacitors for a minimum of 30 minutes, at least 24 hours and not more than 48 hours before the measurements.</p> <p>Capacitance change ≤ ±20 % of the initial value Tanδ ≤ 200 % of the initial specified value Leakage current ≤ 500 % of the initial specified value</p>												
Others	Satisfied characteristics KS C IEC 60384-4												

DIMENSIONS OF NBD Series

Unit(mm)

Marking : DARK BLUE SLEEVE, SILVER INK

øD	10	12.5	16	18	20	22
ød	0.6	0.6	0.8	0.8	0.8	1.0
F	5.0	5.0	7.5	7.5	7.5	10.0
øD'	øD + 0.5 max.					
L'	L + 2.0 max.					

※ ø10 x 12L, L' ≤ L + 1.5

NBD Series

RATINGS OF NBD Series

V _{dc}	160		200		250		350	
Items μF	∅ D×L(mm)	Rated Ripple Current (mArms/105°C, 120Hz)	∅ D×L(mm)	Rated Ripple Current (mArms/105°C, 120Hz)	∅ D×L(mm)	Rated Ripple Current (mArms/105°C, 120Hz)	∅ D×L(mm)	Rated Ripple Current (mArms/105°C, 120Hz)
10					10 x 12	180	10 x 12	168
					10 x 12.5	180	10 x 12.5	168
15					10 x 12	204	10 x 16	176
					10 x 12.5	204	10 x 20	228
22	10 x 12	286	10 x 12	276	10 x 16	278	12.5 x 20	343
	10 x 12.5	286	10 x 12.5	276				
	10 x 16	335	10 x 16	290				
27	10 x 12	330	10 x 16	315	10 x 20	327	12.5 x 20	362
	10 x 12.5	330						
	10 x 16	368						
33	10 x 16	360	10 x 20	373	12.5 x 20	391	12.5 x 20	369
39	10 x 16	365	10 x 20	405	12.5 x 20	429	12.5 x 25	406
47	10 x 20	436	10 x 20	436	12.5 x 20	494	12.5 x 30	521
			12.5 x 20	494				
68	10 x 20	515	12.5 x 20	595	12.5 x 25	665	16 x 25	699
			12.5 x 25	665				
82	10 x 25	575	12.5 x 25	711	12.5 x 30	782	18 x 25	794
	12.5 x 20	575	16 x 20	711				
100	12.5 x 20	650	12.5 x 30	835	16 x 25	828	18 x 31.5	944
			16 x 25	835				
120	10 x 33	745	12.5 x 35	965	16 x 25	907	18 x 35.5	1067
	12.5 x 25	745	16 x 25	927				
150	16 x 25	935	16 x 25	953	18 x 25	1042	18 x 35.5	1197
180	16 x 25	1029	16 x 31.5	1080	18 x 31.5	1169	18 x 40	1336
220	16 x 31.5	1118	18 x 31.5	1310	18 x 31.5	1271		
	18 x 25	1118						
270	16 x 35.5	1271	18 x 35.5	1461				
330	16 x 40	1451	18 x 40	1588				
	18 x 31.5	1422						
470	18 x 40	1780						

V _{dc}	400		420		450		500	
Items μF	∅ D×L(mm)	Rated Ripple Current (mArms/105°C, 120Hz)	∅ D×L(mm)	Rated Ripple Current (mArms/105°C, 120Hz)	∅ D×L(mm)	Rated Ripple Current (mArms/105°C, 120Hz)	∅ D×L(mm)	Rated Ripple Current (mArms/105°C, 120Hz)
6.8							10 x 16	125
8.2	10 x 12	152	10 x 16	130	10 x 16	130	10 x 20	158
	10 x 12.5	152						
10	10 x 16	168	10 x 20	160	10 x 20	160	12.5 x 20	185
22	12.5 x 20	343	12.5 x 20	260	12.5 x 25	285	12.5 x 30	290
27	12.5 x 20	362	12.5 x 20	288	12.5 x 25	325	12.5 x 40	368
33	12.5 x 25	397	12.5 x 30	385	12.5 x 30	385	12.5 x 45	415
			16 x 20	390	16 x 20	390	16 x 25	395
39	12.5 x 25	406	12.5 x 35	428	12.5 x 35	428	12.5 x 50	470
	12.5 x 30	437	16 x 25	450	16 x 25	450	16 x 31.5	460
47	12.5 x 35	533	12.5 x 40	520	12.5 x 40	520	16 x 35.5	525
	16 x 25	554	16 x 25	520	16 x 25	520	18 x 31.5	525
68	12.5 x 40	635	18 x 25	620	18 x 25	620	16 x 45	700
	18 x 25	725			18 x 31.5	660	18 x 35.5	685
82	18 x 31.5	889	18 x 25	678	16 x 40	730	16 x 50	760
			18 x 31.5	730	18 x 31.5	730	18 x 40	745
100	18 x 31.5	944	16 x 45	860	16 x 45	855	18 x 45	900
	18 x 35.5	1,010	18 x 35.5	860	18 x 35.5	855	20 x 40	900
120	18 x 35.5	1,067	16 x 50	950	16 x 50	950	18 x 50	1050
	18 x 40	1,159	18 x 40	950	18 x 40	950		
150	18 x 40	1,296	16 x 50	1,150				
			18 x 45	1,150				
180	18 x 45	1,372						
	20 x 40	1,372						

RATED RIPPLE CURRENT MULTIPLIERS

Frequency Multipliers

Cap. (μF)	Freq. (Hz)	120	1k	10k	50k	100k
6.8~82		1.00	1.75	2.25	2.35	2.50
100~470		1.00	1.67	2.05	2.15	2.25

NBL Series

• 105°C 15,000~20,000Hrs assured.

- Non-solvent proof
- High Ripple, Long Life, Low Temp.
- For SMPS, IP-Board, Adaptor, LED Lighting
- RoHS compliant.
- Halogen-free capacitors are also available.
- AEC-Q200 compliant : Please contact us for more details, test data, information.



Long Life

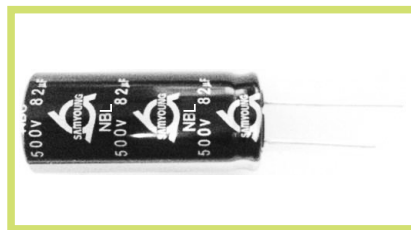

SPECIFICATIONS

Item	Characteristics												
Rated Voltage Range	160~500 V _{DC}												
Operating Temperature Range	-40~ +105°C												
Capacitance Tolerance	±20%(M) (at 20°C, 120Hz)												
Leakage Current	<table border="1"> <thead> <tr> <th>C · V</th> <th>Time</th> <th>After 1 minute</th> <th>After 5 minutes</th> </tr> </thead> <tbody> <tr> <td>≤ 1000</td> <td></td> <td>I = 0.1CV + 40</td> <td>I = 0.03CV + 15</td> </tr> <tr> <td>> 1000</td> <td></td> <td>I = 0.04CV + 100</td> <td>I = 0.02CV + 25</td> </tr> </tbody> </table> <p>Where, I:Max. Leakage current(μA) C:Nominal capacitance(μF) V:Rated voltage(V_{DC}) (at 20°C)</p>	C · V	Time	After 1 minute	After 5 minutes	≤ 1000		I = 0.1CV + 40	I = 0.03CV + 15	> 1000		I = 0.04CV + 100	I = 0.02CV + 25
C · V	Time	After 1 minute	After 5 minutes										
≤ 1000		I = 0.1CV + 40	I = 0.03CV + 15										
> 1000		I = 0.04CV + 100	I = 0.02CV + 25										
Dissipation Factor(Tanδ)	<table border="1"> <thead> <tr> <th>Rated Voltage(V_{DC})</th> <th>160~250</th> <th>350~500</th> </tr> </thead> <tbody> <tr> <td>Tanδ(Max.)</td> <td>0.20</td> <td>0.24</td> </tr> </tbody> </table> <p>(at 20°C, 120Hz)</p>	Rated Voltage(V _{DC})	160~250	350~500	Tanδ(Max.)	0.20	0.24						
Rated Voltage(V _{DC})	160~250	350~500											
Tanδ(Max.)	0.20	0.24											
Temperature Characteristics (Max. Impedance ratio)	<table border="1"> <thead> <tr> <th>Rated Voltage(V_{DC})</th> <th>160~500</th> </tr> </thead> <tbody> <tr> <td>Z(-25°C)/Z(20°C)</td> <td>3</td> </tr> <tr> <td>Z(-40°C)/Z(20°C)</td> <td>6</td> </tr> </tbody> </table> <p>(at 120Hz)</p>	Rated Voltage(V _{DC})	160~500	Z(-25°C)/Z(20°C)	3	Z(-40°C)/Z(20°C)	6						
Rated Voltage(V _{DC})	160~500												
Z(-25°C)/Z(20°C)	3												
Z(-40°C)/Z(20°C)	6												
Load Life	<p>The following specifications shall be satisfied when the capacitors are restored to 20°C after the rated voltage with the rated ripple current is applied (the peak voltage shall not exceed the rated voltage) for 20,000 hours at 105°C. (where 15,000 hours for ø10, ø12.5)</p> <p>Capacitance change ≤ ±20% of the initial value Tanδ ≤ 200% of the initial specified value Leakage current ≤ The initial specified value</p>												
Shelf Life	<p>The following specifications shall be satisfied when the capacitors are restored to 20°C after exposing them for 1,000 hours at 105°C without voltage applied. The rated voltage shall be applied to the capacitors for a minimum of 30 minutes, at least 24 hours and not more than 48 hours before the measurements.</p> <p>Capacitance change ≤ ±20% of the initial value Tanδ ≤ 200% of the initial specified value Leakage current ≤ 500% of the initial specified value</p>												
Others	Satisfied characteristics KS C IEC 60384-4												

DIMENSIONS OF NBL Series

Unit(mm)

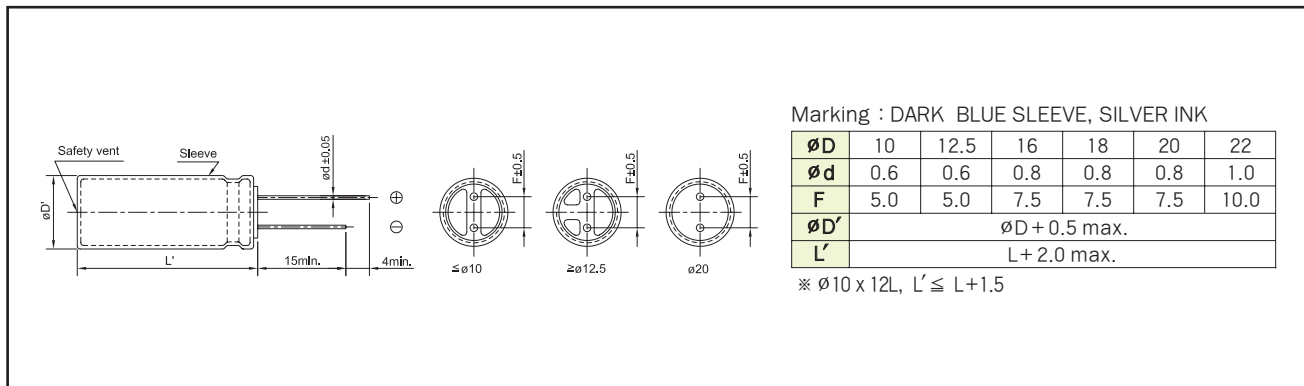

RATINGS OF NBL Series

Vdc	160		200		250		350	
Items μF	∅ D×L(mm)	Rated Ripple Current (mAmps/105°C, 120Hz)	∅ D×L(mm)	Rated Ripple Current (mAmps/105°C, 120Hz)	∅ D×L(mm)	Rated Ripple Current (mAmps/105°C, 120Hz)	∅ D×L(mm)	Rated Ripple Current (mAmps/105°C, 120Hz)
6.8					10×12	119	10×12	105
					10×12.5	119	10×12.5	105
10					10×12	160	10×16	149
					10×12.5	160		
15			10×12	150	10×16	220	10×20	197
			10×12.5	150				
22	10×12	221	10×16	243	10×20	240	12.5×20	297
	10×12.5	221						
	10×16	243						
27	10×16	264	10×20	280	10×20	270	12.5×20	314
33	10×16	270	10×20	308	12.5×20	323	12.5×25	325
39	10×20	320	10×25	350	12.5×20	354	12.5×25	352
47	10×20	369	10×33	450	12.5×25	460	12.5×30	451
			12.5×20	440				
68	10×33	480	12.5×25	594	12.5×30	610	16×31.5	623
82	10×33	520	12.5×30	640	12.5×35	680	18×25	688
	12.5×25	525	16×20	616				
100	12.5×25	575	12.5×35	740	16×25	717	18×31.5	817
			16×25	717				
120	10×50	700	12.5×40	850	16×31.5	804	18×35.5	924
	12.5×30	670	16×25	785				
150	16×25	825	16×31.5	813	16×35.5	902	18×40	1,083
180	16×25	891	16×35.5	951	18×31.5	1,012	18×45	1,230
220	16×31.5	968	18×31.5	1,100	18×35.5	1,121		
	18×25	968						
270	16×35.5	1,100	18×40	1,290				
330	18×31.5	1,231	18×45	1,390				
470	18×45	1,626						

Vdc	400		420		450		500	
Items μF	∅ D×L(mm)	Rated Ripple Current (mAmps/105°C, 120Hz)	∅ D×L(mm)	Rated Ripple Current (mAmps/105°C, 120Hz)	∅ D×L(mm)	Rated Ripple Current (mAmps/105°C, 120Hz)	∅ D×L(mm)	Rated Ripple Current (mAmps/105°C, 120Hz)
3.3							10×12	63
							10×12.5	63
4.7					10×12	76	10×16	83
					10×12.5	76		
6.8					10×16	110	10×20	119
8.2	10×16	140	10×16	113	10×20	122	10×20	141
10	10×16	145	10×20	135	10×20	135	12.5×20	165
22	12.5×20	297	12.5×25	250	12.5×25	250	12.5×35	260
27	12.5×25	330	12.5×25	265	12.5×30	280	12.5×40	329
33	12.5×30	355	12.5×30	340	12.5×35	360	12.5×45	370
			16×20	345	16×25	361	16×31.5	380
39	12.5×35	400	12.5×35	380	12.5×40	400	12.5×50	420
			16×25	400	16×31.5	423	16×35.5	434
47	12.5×40	485	12.5×40	450	12.5×50	470	18×31.5	468
	16×25	480	16×25	450	16×31.5	478		
68	12.5×50	575	18×31.5	580	18×31.5	580	18×40	630
	16×35.5	627						
82	16×40	770	16×40	620	18×35.5	650	18×45	685
100	18×35.5	875	18×35.5	770	18×40	794	22×40	800
120	18×40	1,003	18×45	900	18×50	940	22×50	960
150	18×50	1,192						

RATED RIPPLE CURRENT MULTIPLIERS

Frequency Multipliers

Cap.(μF)	Freq.(Hz)	120	1k	10k	50k	100k
3.3~82		1.00	1.75	2.25	2.35	2.50
		1.00	1.67	2.05	2.15	2.25

NBH Series

• 105°C 20,000Hrs assured.

- Non-solvent proof
- High Ripple and Long Life, Low Temp.
- For SMPS, IP-Board, Adaptor, LED Lighting
- RoHS compliant.
- Halogen-free capacitors are also available.

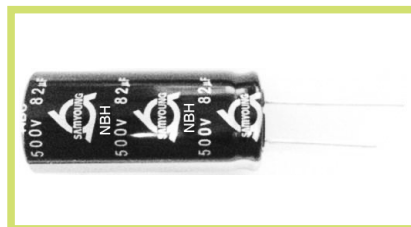

• AEC-Q200 compliant : Please contact us for more details, test data, information. High Ripple

SPECIFICATIONS

Item	Characteristics												
Rated Voltage Range	160~500 V _{DC}												
Operating Temperature Range	-40~ +105°C												
Capacitance Tolerance	±20%(M) (at 20°C, 120Hz)												
Leakage Current	<table border="1"> <thead> <tr> <th>C · V</th> <th>Time</th> <th>After 1 minute</th> <th>After 5 minutes</th> </tr> </thead> <tbody> <tr> <td>≤ 1000</td> <td></td> <td>I = 0.1CV + 40</td> <td>I = 0.03CV + 15</td> </tr> <tr> <td>> 1000</td> <td></td> <td>I = 0.04CV + 100</td> <td>I = 0.02CV + 25</td> </tr> </tbody> </table> <p>Where, I:Max. Leakage current(μA) C:Nominal capacitance(μF) V:Rated voltage(V_{DC}) (at 20°C)</p>	C · V	Time	After 1 minute	After 5 minutes	≤ 1000		I = 0.1CV + 40	I = 0.03CV + 15	> 1000		I = 0.04CV + 100	I = 0.02CV + 25
C · V	Time	After 1 minute	After 5 minutes										
≤ 1000		I = 0.1CV + 40	I = 0.03CV + 15										
> 1000		I = 0.04CV + 100	I = 0.02CV + 25										
Dissipation Factor(Tanδ)	<table border="1"> <thead> <tr> <th>Rated Voltage(V_{DC})</th> <th>160~250</th> <th>350~500</th> </tr> </thead> <tbody> <tr> <td>Tanδ(Max.)</td> <td>0.20</td> <td>0.24</td> </tr> </tbody> </table> <p>(at 20°C, 120Hz)</p>	Rated Voltage(V _{DC})	160~250	350~500	Tanδ(Max.)	0.20	0.24						
Rated Voltage(V _{DC})	160~250	350~500											
Tanδ(Max.)	0.20	0.24											
Temperature Characteristics (Max. Impedance ratio)	<table border="1"> <thead> <tr> <th>Rated Voltage(V_{DC})</th> <th>160~500</th> </tr> </thead> <tbody> <tr> <td>Z(-25°C)/Z(20°C)</td> <td>3</td> </tr> <tr> <td>Z(-40°C)/Z(20°C)</td> <td>6</td> </tr> </tbody> </table> <p>(at 120Hz)</p>	Rated Voltage(V _{DC})	160~500	Z(-25°C)/Z(20°C)	3	Z(-40°C)/Z(20°C)	6						
Rated Voltage(V _{DC})	160~500												
Z(-25°C)/Z(20°C)	3												
Z(-40°C)/Z(20°C)	6												
Load Life	<p>The following specifications shall be satisfied when the capacitors are restored to 20°C after the rated voltage with the rated ripple current is applied (the peak voltage shall not exceed the rated voltage) for 20,000 hours at 105°C.</p> <p>Capacitance change ≤ ±20% of the initial value Tanδ ≤ 200% of the initial specified value Leakage current ≤ The initial specified value</p>												
Shelf Life	<p>The following specifications shall be satisfied when the capacitors are restored to 20°C after exposing them for 1,000 hours at 105°C without voltage applied. The rated voltage shall be applied to the capacitors for a minimum of 30 minutes, at least 24 hours and not more than 48 hours before the measurements.</p> <p>Capacitance change ≤ ±20% of the initial value Tanδ ≤ 200% of the initial specified value Leakage current ≤ 500% of the initial specified value</p>												
Others	Satisfied characteristics KS C IEC 60384-4												

DIMENSIONS OF NBH Series

Unit(mm)

Marking : DARK BLUE SLEEVE, SILVER INK

øD	16	18	20	22
ød	0.8	0.8	0.8	1.0
F	7.5	7.5	7.5	10.0
øD'	øD + 0.5 max.			
L'	L + 2.0 max.			

RATINGS OF NBH Series

V _{dc}	160		200		250		350	
Items μF	∅ D×L(mm)	Rated Ripple Current (mA _{rms} /105°C, 120Hz)	∅ D×L(mm)	Rated Ripple Current (mA _{rms} /105°C, 120Hz)	∅ D×L(mm)	Rated Ripple Current (mA _{rms} /105°C, 120Hz)	∅ D×L(mm)	Rated Ripple Current (mA _{rms} /105°C, 120Hz)
68							16×31.5	685
82			16×20	678			18×25	756
100			16×25	789	16×25	789	18×31.5	899
120			16×25	864	16×31.5	884	18×35.5	1,016
150	16×25	908	16×31.5	894	16×35.5	992	18×40	1,191
180	16×25	980	16×35.5	1,046	18×31.5	1,113	18×45	1,353
220	16×31.5	1,065	18×31.5	1,210	18×35.5	1,233		
	18×25	1,065						
270	16×35.5	1,210	18×40	1,419				
330	18×31.5	1,354	18×45	1,529				
470	18×40	1,789						

V _{dc}	400		420		450		500	
Items μF	∅ D×L(mm)	Rated Ripple Current (mA _{rms} /105°C, 120Hz)	∅ D×L(mm)	Rated Ripple Current (mA _{rms} /105°C, 120Hz)	∅ D×L(mm)	Rated Ripple Current (mA _{rms} /105°C, 120Hz)	∅ D×L(mm)	Rated Ripple Current (mA _{rms} /105°C, 120Hz)
33			16×20	380	16×25	397	16×31.5	418
39			16×25	440	16×31.5	465	16×35.5	477
47	16×25	528	16×25	495	16×31.5	526	18×31.5	515
68	16×35.5	690	18×31.5	638	18×31.5	638	18×40	693
82	16×40	847	16×40	682	18×35.5	715	18×45	754
100	18×35.5	962	18×35.5	847	18×40	873	22×35	820
120	18×40	1,100	18×45	990	18×50	1,000	22×45	950
150	18×50	1,300					22×50	1,030

RATED RIPPLE CURRENT MULTIPLIERS

Frequency Multipliers

Cap.(μF)	Freq.(Hz)	120	1k	10k	50k	100k
33~82		1.00	1.75	2.25	2.35	2.50
100~470		1.00	1.67	2.05	2.15	2.25

NLA Series

• 105°C 4,000~10,000Hrs assured.

Solvent-proof

- Low impedance.
- Long Life.
- For SMPS, IP-Board, Adaptor.
- RoHS compliant.
- Halogen-free capacitors are also available.



Low Imp.
Long Life



SPECIFICATIONS

Item	Characteristics																					
Rated Voltage Range	6.3 ~ 50 V _{DC}																					
Operating Temperature Range	-55 ~ +105°C																					
Capacitance Tolerance	±20%(M) (at 20°C, 120Hz)																					
Leakage Current	I=0.01CV or 3µA, whichever is greater. Where, I: Max.Leakage current(µA) C: Nominal capacitance (µF) V: Rated voltage (V _{DC}) (at 20°C, 2 minutes)																					
Dissipation Factor(Tanδ)	<table border="1"> <tr> <td>Rated Voltage(V_{DC})</td> <td>6.3</td> <td>10</td> <td>16</td> <td>25</td> <td>35</td> <td>50</td> </tr> <tr> <td>Tanδ(Max.)</td> <td>0.22</td> <td>0.19</td> <td>0.16</td> <td>0.14</td> <td>0.12</td> <td>0.10</td> </tr> </table> <p>When the capacitance exceeds 1,000µF, 0.02 shall be added every 1,000µF increase. (at 20°C, 120Hz)</p>	Rated Voltage(V _{DC})	6.3	10	16	25	35	50	Tanδ(Max.)	0.22	0.19	0.16	0.14	0.12	0.10							
Rated Voltage(V _{DC})	6.3	10	16	25	35	50																
Tanδ(Max.)	0.22	0.19	0.16	0.14	0.12	0.10																
Temperature Characteristics (Max. Impedance ratio)	<table border="1"> <tr> <td>Rated voltage(V_{DC})</td> <td>6.3</td> <td>10</td> <td>16</td> <td>25</td> <td>35</td> <td>50</td> </tr> <tr> <td>Z(-25°C)/Z(+20°C)</td> <td>4</td> <td>3</td> <td>2</td> <td>2</td> <td>2</td> <td>2</td> </tr> <tr> <td>Z(-40°C)/Z(+20°C)</td> <td>8</td> <td>6</td> <td>4</td> <td>3</td> <td>3</td> <td>4</td> </tr> </table> <p>(at 120Hz)</p>	Rated voltage(V _{DC})	6.3	10	16	25	35	50	Z(-25°C)/Z(+20°C)	4	3	2	2	2	2	Z(-40°C)/Z(+20°C)	8	6	4	3	3	4
Rated voltage(V _{DC})	6.3	10	16	25	35	50																
Z(-25°C)/Z(+20°C)	4	3	2	2	2	2																
Z(-40°C)/Z(+20°C)	8	6	4	3	3	4																
Load Life	<p>The following specifications shall be satisfied when the capacitors are restored to 20°C after the rated voltage with the rated ripple current is applied (the peak voltage shall not exceed the rated voltage) at 105°C for the following test time.</p> <table border="1"> <tr> <td>∅ D</td> <td>6.3~10V</td> <td>16~50V</td> </tr> <tr> <td>∅ 5~6.3</td> <td>4,000 hours</td> <td>5,000 hours</td> </tr> <tr> <td>∅ 8~10</td> <td>6,000 hours</td> <td>7,000 hours</td> </tr> <tr> <td>∅ 12.5~</td> <td>8,000 hours</td> <td>10,000 hours</td> </tr> </table> <p>Capacitance change ≤ ±25% of the initial value Tanδ ≤ 200% of the initial specified value Leakage current ≤ The initial specified value</p>	∅ D	6.3~10V	16~50V	∅ 5~6.3	4,000 hours	5,000 hours	∅ 8~10	6,000 hours	7,000 hours	∅ 12.5~	8,000 hours	10,000 hours									
∅ D	6.3~10V	16~50V																				
∅ 5~6.3	4,000 hours	5,000 hours																				
∅ 8~10	6,000 hours	7,000 hours																				
∅ 12.5~	8,000 hours	10,000 hours																				
Shelf Life	<p>The following specifications shall be satisfied when the capacitors are restored to 20°C after exposing them for 1,000 hours at 105°C without voltage applied. The rated voltage shall be applied to the capacitors for a minimum of 30 minutes, at least 24 hours and not more than 48 hours before the measurements.</p> <p>Capacitance change ≤ ±25% of the initial value Tanδ ≤ 200% of the initial specified value Leakage current ≤ The initial specified value</p>																					
Others	Satisfied characteristics KS C IEC 60384-4																					

DIMENSIONS OF NLA Series

Unit(mm)

Marking : DARK BROWN SLEEVE, SILVER INK

∅D	5	6.3	8	10	12.5	16	18
∅d	0.5	0.5	0.6	0.6	0.6	0.8	0.8
F	2.0	2.5	3.5	5.0	5.0	7.5	7.5
∅D'	∅D + 0.5 max.						
L'	L + 1.5 max.			L + 2.0 max			

RATINGS OF NLA Series

∅D×L(mm)	Vdc	6.3			10			16		
		μF	IMP.	Ripple	μF	IMP.	Ripple	μF	IMP.	Ripple
5×11		150	0.50	175	100	0.50	175	47	0.50	175
6.3×11		330	0.25	290	220	0.25	290	100	0.25	290
8×11.5		680	0.12	555	470	0.12	555	330	0.12	555
8×15		1,000	0.090	730	680	0.090	730	470	0.090	730
8×20		1,200	0.080	810	1,000	0.080	810	560	0.080	810
10×12.5		820	0.090	760	680	0.090	760	470	0.090	760
10×16		1,200	0.068	1,050	1,000	0.068	1,050	680	0.068	1,050
10×20		1,500	0.052	1,220	1,200	0.052	1,220	1,000	0.052	1,220
10×25		2,200	0.045	1,440	1,500	0.045	1,440	1,200	0.045	1,440
10×30		2,700	0.037	1,690	1,800	0.037	1,690	1,500	0.037	1,690
12.5×16		1,800	0.053	1,270	1,500	0.053	1,270	1,000	0.053	1,270
12.5×20		3,300	0.038	1,660	2,200	0.038	1,660	1,500	0.038	1,660
12.5×25		3,900	0.030	2,310	3,300	0.030	2,310	2,200	0.030	2,310
12.5×30		4,700	0.025	2,510	3,900	0.025	2,510	2,700	0.025	2,510
12.5×35		5,600	0.022	2,870	4,700	0.022	2,870	3,300	0.022	2,870
16×15		2,700	0.048	1,690	2,200	0.048	1,690	1,500	0.048	1,690
16×20		5,600	0.031	2,210	3,900	0.031	2,210	2,700	0.031	2,210
16×25		6,800	0.024	2,560	5,600	0.024	2,560	3,900	0.024	2,560
16×31.5		8,200	0.021	3,010	6,800	0.021	3,010	4,700	0.021	3,010
16×35		10,000	0.019	3,250	8,200	0.019	3,250	5,600	0.019	3,250
16×40		12,000	0.016	3,560	10,000	0.016	3,560	6,800	0.016	3,560
18×20		6,800	0.031	2,490	5,600	0.031	2,490	3,900	0.031	2,490
18×25		10,000	0.023	2,740	6,800	0.023	2,740	4,700	0.023	2,740
18×31.5		12,000	0.021	3,330	8,200	0.021	3,330	5,600	0.021	3,330
18×35.5		15,000	0.019	3,680	10,000	0.019	3,680	8,200	0.019	3,680
18×40		18,000	0.018	3,800	12,000	0.018	3,800	10,000	0.018	4,280

∅D×L(mm)	Vdc	25			35			50		
		μF	IMP.	Ripple	μF	IMP.	Ripple	μF	IMP.	Ripple
5×11		47	0.50	175	33	0.50	175	10	2.0	100
6.3×11		100	0.25	290	56	0.25	290	22	1.6	150
8×11.5		220	0.12	555	150	0.12	555	47	0.80	180
8×15		330	0.090	730	220	0.090	730	100	0.50	230
8×20		390	0.080	810	270	0.080	810	120	0.30	360
10×12.5		330	0.090	760	220	0.090	760	100	0.28	380
10×16		470	0.068	1,050	330	0.068	1,050	150	0.19	525
10×20		680	0.052	1,220	470	0.052	1,220	220	0.14	610
10×25		820	0.045	1,440	560	0.045	1,440	270	0.11	720
10×30		1,000	0.037	1,690	680	0.037	1,690	330	0.091	845
12.5×16		680	0.053	1,270	470	0.053	1,270	220	0.15	630
12.5×20		1,000	0.038	1,660	680	0.038	1,660	330	0.098	830
12.5×25		1,500	0.030	2,310	1,000	0.030	2,310	470	0.074	975
12.5×30		1,800	0.025	2,510	1,200	0.025	2,510	680	0.062	1,150
12.5×35		2,200	0.022	2,870	1,500	0.022	2,870	820	0.052	1,250
16×15		1,000	0.048	1,690	680	0.048	1,690	390	0.11	845
16×20		1,800	0.031	2,210	1,200	0.031	2,210	680	0.070	1,100
16×25		2,700	0.024	2,560	1,800	0.024	2,560	820	0.052	1,280
16×31.5		3,300	0.021	3,010	2,200	0.021	3,010	1,000	0.045	1,500
16×35		3,900	0.019	3,250	2,700	0.019	3,250	1,200	0.039	1,680
16×40		4,700	0.016	3,560	3,300	0.016	3,560	1,500	0.033	1,850
18×20		2,200	0.031	2,490	1,800	0.031	2,490	680	0.074	1,250
18×25		3,300	0.023	2,740	2,200	0.023	2,740	1,000	0.054	1,370
18×31.5		3,900	0.021	3,330	2,700	0.021	3,330	1,200	0.043	1,810
18×35.5		4,700	0.019	3,680	3,300	0.019	3,680	1,500	0.035	1,850
18×40		5,600	0.012	4,280	3,900	0.012	4,280	1,800	0.029	1,900

RATED RIPPLE CURRENT MULTIPLIERS

Frequency Multipliers

Cap.(μF)	Freq.(Hz)	120	1k	10k	50k	100k
10 ~ 150		0.40	0.75	0.90	0.93	1.00
220 ~ 560		0.50	0.85	0.94	0.96	1.00
680 ~ 1,800		0.60	0.87	0.95	0.97	1.00
2,200 ~ 3,900		0.75	0.90	0.95	0.97	1.00
4,700 ~ 18,000		0.85	0.95	0.98	0.99	1.00

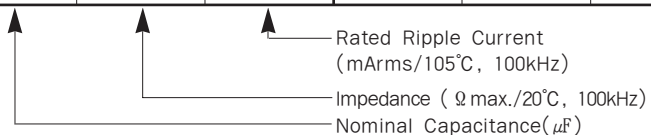

NLC Series

• 105°C 10,000Hrs assured.

- Low impedance.
- Long Life.
- For SMPS, IP-Board, Adaptor.
- RoHS compliant.
- Halogen-free capacitors are also available.

Solvent-proof

WV ≤ 50V_{DC}

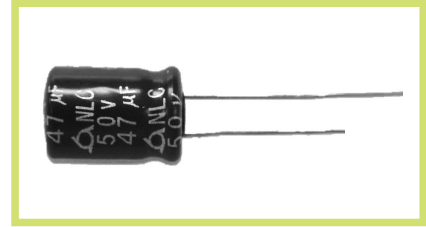
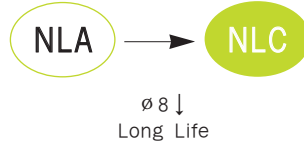

SPECIFICATIONS

Item	Characteristics																		
Rated Voltage Range	6.3 ~ 100 V _{DC}																		
Operating Temperature Range	-40 ~ +105°C																		
Capacitance Tolerance	±20%(M) (at 20°C, 120Hz)																		
Leakage Current	I=0.01CV(μA) or 3μA, whichever is greater. Where, I: Max.Leakage current(μA) C: Nominal capacitance (μF) V: Rated voltage (V _{DC}) (at 20°C, 2 minutes)																		
Dissipation Factor(Tanδ)	<table border="1"> <tr> <td>Rated Voltage(V_{DC})</td> <td>6.3</td> <td>10</td> <td>16</td> <td>25</td> <td>35</td> <td>50</td> <td>63</td> <td>100</td> </tr> <tr> <td>Tanδ(Max.)</td> <td>0.22</td> <td>0.19</td> <td>0.16</td> <td>0.14</td> <td>0.12</td> <td>0.10</td> <td>0.17</td> <td>0.15</td> </tr> </table> <p>When the capacitance exceeds 1,000μF, 0.02 shall be added every 1,000μF increase. (at 20°C, 120Hz)</p>	Rated Voltage(V _{DC})	6.3	10	16	25	35	50	63	100	Tanδ(Max.)	0.22	0.19	0.16	0.14	0.12	0.10	0.17	0.15
Rated Voltage(V _{DC})	6.3	10	16	25	35	50	63	100											
Tanδ(Max.)	0.22	0.19	0.16	0.14	0.12	0.10	0.17	0.15											
Temperature Characteristics (Max. Impedance ratio)	<table border="1"> <tr> <td>Rated voltage(V_{DC})</td> <td>6.3</td> <td>10</td> <td>16</td> <td>25~35</td> <td>50~100</td> </tr> <tr> <td>Z(-25°C)/Z(+20°C)</td> <td>4</td> <td>3</td> <td>2</td> <td>2</td> <td>2</td> </tr> <tr> <td>Z(-40°C)/Z(+20°C)</td> <td>8</td> <td>6</td> <td>4</td> <td>3</td> <td>4</td> </tr> </table> <p>(at 120Hz)</p>	Rated voltage(V _{DC})	6.3	10	16	25~35	50~100	Z(-25°C)/Z(+20°C)	4	3	2	2	2	Z(-40°C)/Z(+20°C)	8	6	4	3	4
Rated voltage(V _{DC})	6.3	10	16	25~35	50~100														
Z(-25°C)/Z(+20°C)	4	3	2	2	2														
Z(-40°C)/Z(+20°C)	8	6	4	3	4														
Load Life	The following specifications shall be satisfied when the capacitors are restored to 20°C after the rated voltage with the rated ripple current is applied (the peak voltage shall not exceed the rated voltage) for 10,000 hours at 105°C. Capacitance change ≤ ±25% of the initial value Tanδ ≤ 200% of the initial specified value Leakage current ≤ The initial specified value																		
Shelf Life	The following specifications shall be satisfied when the capacitors are restored to 20°C after exposing them for 1,000 hours at 105°C without voltage applied. The rated voltage shall be applied to the capacitors for a minimum of 30 minutes, at least 24 hours and not more than 48 hours before the measurements. Capacitance change ≤ ±25% of the initial value Tanδ ≤ 200% of the initial specified value(where, 300% for ≥WV63VDC) Leakage current ≤ The initial specified value																		
Others	Satisfied characteristics KS C IEC 60384-4																		

DIMENSIONS OF NLC Series

Unit(mm)

Marking : DARK BROWN SLEEVE, SILVER INK

øD	5	6.3	8
ød	0.5	0.5	0.6
F	2.0	2.5	3.5
øD'	øD + 0.5 max.		
L'	L + 1.5 max.		

NLC Series

RATINGS OF NLC Series

V _{bc} ∅ D×L(mm)	6.3			10			16		
	μF	IMP.	Ripple	μF	IMP.	Ripple	μF	IMP.	Ripple
5 × 11	150	0.70	175	100	0.70	175	47	0.70	175
6.3 × 11	330	0.50	252	220	0.50	250	100	0.50	252
8 × 11.5	680	0.24	400	470	0.24	400	330	0.24	400

V _{bc} ∅ D×L(mm)	25			35			50		
	μF	IMP.	Ripple	μF	IMP.	Ripple	μF	IMP.	Ripple
5 × 11							1	4.0	32
5 × 11							2.2	3.0	43
5 × 11							3.3	2.5	84
5 × 11							4.7	2.5	100
5 × 11	47	0.70	175	33	0.70	175	10	2.0	110
6.3 × 11	100	0.50	252	47	0.60	252	22	1.6	228
6.3 × 11				56	0.50	252	33	1.6	228
8 × 11.5	220	0.24	400	150	0.24	400	47	0.80	330
8 × 15				220	0.18	520	100	0.50	400

↑ Impedance (Ω max./20°C, 100kHz)

V _{bc} ∅ D×L(mm)	63		100	
	μF	Ripple	μF	Ripple
8 × 11.5	47	270	33	240

↑ Rated Ripple Current (mArms/105°C, 100kHz)
 ↑ Nominal Capacitance(μF)

RATED RIPPLE CURRENT MULTIPLIERS

Frequency Multipliers

Cap.(μF) Freq.(Hz)	120	1k	10k	50k	100k
1 ~ 150	0.40	0.75	0.90	0.93	1.00
220 ~ 470	0.50	0.85	0.94	0.96	1.00
680	0.60	0.87	0.95	0.97	1.00

PXB Series

• 125°C 2,000~5,000Hrs assured.

- Low impedance.
- Wide Temperature range.
- Long Life.
- Suitable to fit for automotive equipment.
- RoHS compliant.
- Halogen-free capacitors are also available.

• AEC-Q200 compliant : Please contact us for more details, test data, information.

Solvent-proof

WV \leq 80V_{DC}



Long Life

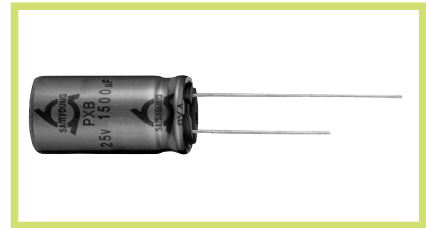

SPECIFICATIONS

Item	Characteristics																				
Rated Voltage Range	10 ~ 100 V _{DC}	160 ~ 400 V _{DC}	450 V _{DC}																		
Operating Temperature Range	-40 ~ +125°C	-40 ~ +125°C	-25 ~ +125°C																		
Capacitance Tolerance	$\pm 20\%$ (M) (at 20°C, 120Hz)																				
Leakage Current	I = 0.03CV (μ A) or 4 μ A, whichever is greater.	CV \leq 1,000	CV > 1,000																		
		I = 0.1CV + 40	I = 0.04CV + 100																		
Where, I : Max. Leakage current (μ A) C : Nominal capacitance (μ F) V : Rated voltage(V _{DC}) (at 20°C, 1 minute)																					
Dissipation Factor(Tan δ)	Rated voltage(V _{DC})	10	16	25	35	50~63	80~100	160~250	350~450												
	Tan δ (Max.)	0.20	0.16	0.14	0.12	0.10	0.08	0.20	0.24												
When the capacitance exceeds 1,000 μ F, 0.02 shall be added every 1,000 μ F increase. (at 20°C, 120Hz)																					
Temperature Characteristics (Max. Impedance ratio)	Rated Voltage(V _{DC})	10	16~35	50~80	100	160~250	350~400	450													
	Z(-25°C)/Z(+20°C)	3	2	3	3	3	6	6													
	Z(-40°C)/Z(+20°C)	6	4	5	6	6	10	-													
(at 120Hz)																					
Load Life	The following specifications shall be satisfied when the capacitors are restored to 20°C after the rated voltage is applied at 125°C.								<table border="1"> <tr> <td>ϕ D</td> <td>10~100V</td> <td>160~450V</td> </tr> <tr> <td>ϕ 5~6.3</td> <td>2,000 hours</td> <td>-</td> </tr> <tr> <td>ϕ 8</td> <td>3,000 hours</td> <td>5,000 hours</td> </tr> <tr> <td>ϕ 10~</td> <td>5,000 hours</td> <td></td> </tr> </table>	ϕ D	10~100V	160~450V	ϕ 5~6.3	2,000 hours	-	ϕ 8	3,000 hours	5,000 hours	ϕ 10~	5,000 hours	
	ϕ D	10~100V	160~450V																		
ϕ 5~6.3	2,000 hours	-																			
ϕ 8	3,000 hours	5,000 hours																			
ϕ 10~	5,000 hours																				
Capacitance change	$\leq \pm 30\%$ of the initial value (where, $\pm 20\%$ for \geq WV 160V _{DC})																				
Tan δ	$\leq 300\%$ of the initial specified value (where, 200% for \geq WV 160V _{DC})																				
Leakage current	\leq The initial specified value																				
Shelf Life	The following specifications shall be satisfied when the capacitors are restored to 20°C after exposing them for 1,000 hours at 125°C without voltage applied. The rated voltage shall be applied to the capacitors for a minimum of 30 minutes, at least 24 hours and not more than 48 hours before the measurements.																				
	Capacitance change	$\leq \pm 30\%$ of the initial value (where, $\pm 20\%$ for \geq WV 160V _{DC})																			
	Tan δ	$\leq 300\%$ of the initial specified value (where, 200% for \geq WV 160V _{DC})																			
	Leakage current	\leq The initial specified value (where, 500% for \geq WV 160V _{DC})																			
Others	Satisfied characteristics KS C IEC 60384-4																				

DIMENSIONS OF PXB Series

Unit(mm)

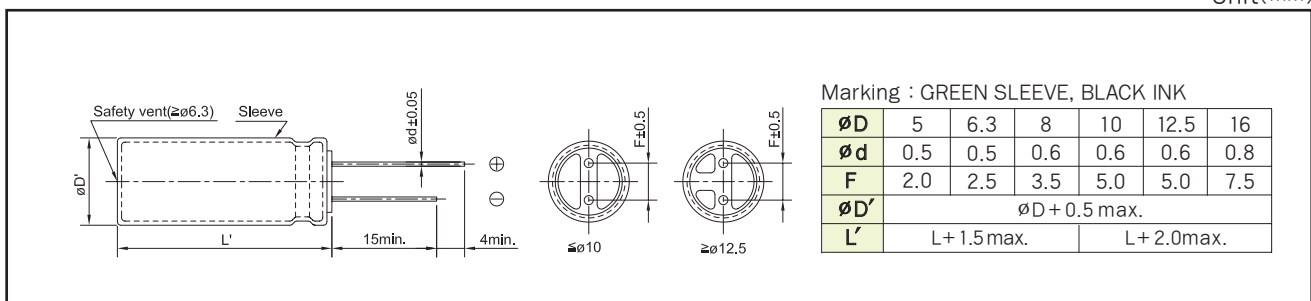

RATINGS OF PXB Series

V _{dc}	10			16			25			35			
	Items	∅ D × L (mm)	Imp. (∅ max.)	Rated Ripple Current (mArms)	∅ D × L (mm)	Imp. (∅ max.)	Rated Ripple Current (mArms)	∅ D × L (mm)	Imp. (∅ max.)	Rated Ripple Current (mArms)	∅ D × L (mm)	Imp. (∅ max.)	Rated Ripple Current (mArms)
			(20°C, 100kHz)										
22											5 × 11	3.0	128
33								5 × 11	3.0	128	6.3 × 11	1.0	180
47					5 × 11	3.0	128	6.3 × 11	1.0	180	6.3 × 11	1.0	220
68		5 × 11	3.0	128	6.3 × 11	1.0	180	6.3 × 11	1.0	220	8 × 11.5	0.35	307
100		5 × 11	3.0	150	6.3 × 11	1.0	220	8 × 11.5	0.35	325	8 × 11.5	0.35	325
		6.3 × 11	1.0	180	8 × 11.5	0.35	325				10 × 12.5	0.25	480
220		6.3 × 11	1.0	220	8 × 11.5	0.35	368	10 × 12.5	0.25	480	10 × 16	0.15	625
		8 × 11.5	0.35	325	10 × 12.5	0.25	480				10 × 20	0.11	799
330		10 × 12.5	0.25	480	10 × 12.5	0.25	480	10 × 16	0.15	625	12.5 × 20	0.068	997
470		10 × 12.5	0.25	480	10 × 16	0.15	625	10 × 20	0.11	799			
1,000		10 × 20	0.11	799	12.5 × 20	0.068	997	12.5 × 25	0.058	1,121	16 × 25	0.040	1,426
2,200		12.5 × 25	0.058	997	16 × 25	0.040	1,426	16 × 31.5	0.034	1,595			
3,300		16 × 25	0.040	1,426	16 × 31.5	0.034	1,595						
4,700		16 × 31.5	0.034	1,595									

V _{dc}	50			63			80			100			
	Items	∅ D × L (mm)	Imp. (∅ max.)	Rated Ripple Current (mArms)	∅ D × L (mm)	Imp. (∅ max.)	Rated Ripple Current (mArms)	∅ D × L (mm)	Imp. (∅ max.)	Rated Ripple Current (mArms)	∅ D × L (mm)	Imp. (∅ max.)	Rated Ripple Current (mArms)
			(20°C, 100kHz)										
1		5 × 11	5.2	29									
1.5		5 × 11	5.2	38									
2.2		5 × 11	5.2	45									
3.3		5 × 11	5.2	55									
4.7		5 × 11	5.2	67									
6.8		5 × 11	5.2	75									
10		5 × 11	2.5	92									
		8 × 11.5	0.75	180							8 × 11.5	1.7	140
22		5 × 11	2.5	162									
		8 × 11.5	0.50	250				8 × 11.5	1.5	150	10 × 12.5	0.94	440
33		8 × 11.5	0.50	280	8 × 11.5	1.5	150	10 × 12.5	0.80	480	10 × 12.5	0.94	440
47		8 × 11.5	0.50	280	10 × 12.5	0.80	480	10 × 12.5	0.80	480	10 × 16	0.68	600
100		10 × 12.5	0.25	480	10 × 16	0.58	650	10 × 20	0.39	790	12.5 × 20	0.32	870
220		10 × 20	0.15	625	12.5 × 20	0.27	950	12.5 × 25	0.18	1,240	16 × 25	0.14	1,320
330		12.5 × 20	0.081	990	12.5 × 25	0.18	1,240	12.5 × 30	0.16	1,390	16 × 31.5	0.12	1,400
470		12.5 × 25	0.070	1,150	12.5 × 30	0.16	1,390	16 × 25	0.11	1,500			
1,000		16 × 31.5	0.032	1,590	16 × 31.5	0.090	1,650						

V _{dc}	160		200		250		350		400		450		
	Items	∅ D × L (mm)	Rated Ripple Current (mArms)	∅ D × L (mm)	Rated Ripple Current (mArms)	∅ D × L (mm)	Rated Ripple Current (mArms)	∅ D × L (mm)	Rated Ripple Current (mArms)	∅ D × L (mm)	Rated Ripple Current (mArms)		
			(125°C, 120Hz)		(125°C, 120Hz)		(125°C, 120Hz)		(125°C, 120Hz)		(125°C, 120Hz)	(125°C, 120Hz)	
3.3									8 × 11.5	48			
4.7				8 × 11.5	53				10 × 12.5	65			
6.8				8 × 15	71	8 × 11.5	70	8 × 11.5	75	10 × 16	86	10 × 16	80
10		8 × 11.5	80	8 × 15	86	10 × 12.5	91	10 × 16	105	10 × 20	112	10 × 20	108
15		8 × 15	108	10 × 12.5	110	10 × 16	115	10 × 20	139	12.5 × 20	153	12.5 × 20	150
22		10 × 12.5	135	10 × 20	159	12.5 × 20	167	12.5 × 25	204	12.5 × 25	202	16 × 25	242
		10 × 16	151							12.5 × 30	217		
33		10 × 20	204	12.5 × 20	216	12.5 × 25	223	16 × 25	276	16 × 25	273	16 × 31.5	321
47		12.5 × 20	242	12.5 × 25	281	16 × 25	294	16 × 31.5	355	16 × 31.5	351		
68		12.5 × 25	317	16 × 20	348	16 × 31.5	381						
100		16 × 25	424	16 × 25	452								
150		16 × 31.5	481										

RATED RIPPLE CURRENT MULTIPLIERS

Frequency Multipliers

(10 ~ 100V_{DC})

Cap. (μF)	Freq. (Hz)				
	120	1k	10k	50k	100k
1 ~ 100	0.40	0.75	0.90	0.93	1.00
220 ~ 470	0.50	0.85	0.94	0.96	1.00
1,000	0.60	0.87	0.95	0.97	1.00
2,200 ~ 3,300	0.75	0.90	0.95	0.97	1.00
4,700	0.85	0.95	0.98	0.99	1.00

(160 ~ 450V_{DC})

Cap. (μF)	Freq. (Hz)				
	120	1k	10k	50k	100k
3.3 ~ 33	1.00	1.50	1.75	1.76	1.80
47 ~ 150	1.00	1.30	1.40	1.43	1.50

PXD Series

• 125°C 2,000~5,000Hrs assured.

- Ultra Low Impedance.
- Wide Temperature range.
- Long Life.
- Suitable to fit for automotive equipment.
- RoHS compliant.
- Halogen-free capacitors are also available.
- AEC-Q200 compliant : Please contact us for more details, test data, information.

Solvent-proof

WV ≤ 80V_{DC}

PXC

PXD

Low Imp.

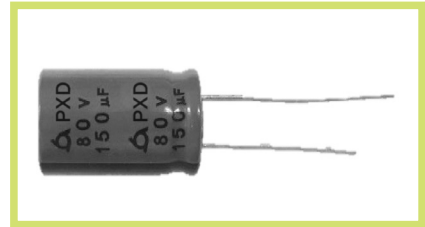

SPECIFICATIONS

Item	Characteristics															
Rated Voltage Range	10 ~ 80 V _{DC}															
Operating Temperature Range	-40 ~ +125°C															
Capacitance Tolerance	±20%(M) (at 20°C,120Hz)															
Leakage Current	$I = 0.03CV (\mu A)$ or $4\mu A$, whichever is greater. Where, I:Max. Leakage current(μA),C:Nominal capacitance(μF),V:Rated voltage(V _{DC}) (at 20°C, 1 minute)															
Dissipation Factor(Tan δ)	<table border="1"> <tr> <td>Rated Volatag(V_{DC})</td> <td>10</td> <td>16</td> <td>25</td> <td>35</td> <td>50~63</td> <td>80</td> </tr> <tr> <td>TANδ(Max.)</td> <td>0.20</td> <td>0.16</td> <td>0.14</td> <td>0.12</td> <td>0.10</td> <td>0.08</td> </tr> </table> When the capacitance exceeds 1,000 μF , 0.02 shall be added every 1,000 μF increase. (at 20°C,120Hz)	Rated Volatag(V _{DC})	10	16	25	35	50~63	80	TAN δ (Max.)	0.20	0.16	0.14	0.12	0.10	0.08	
Rated Volatag(V _{DC})	10	16	25	35	50~63	80										
TAN δ (Max.)	0.20	0.16	0.14	0.12	0.10	0.08										
Temperature Characteristics (Max. Impedance ratio)	<table border="1"> <tr> <td>Rated Voltage(V_{DC})</td> <td>10</td> <td>16 ~ 35</td> <td>50</td> <td>63~80</td> </tr> <tr> <td>Z(-25°C)/Z(+20°C)</td> <td>3</td> <td>2</td> <td>3</td> <td>2</td> </tr> <tr> <td>Z(-40°C)/Z(+20°C)</td> <td>6</td> <td>4</td> <td>5</td> <td>4</td> </tr> </table> (at 120Hz)	Rated Voltage(V _{DC})	10	16 ~ 35	50	63~80	Z(-25°C)/Z(+20°C)	3	2	3	2	Z(-40°C)/Z(+20°C)	6	4	5	4
Rated Voltage(V _{DC})	10	16 ~ 35	50	63~80												
Z(-25°C)/Z(+20°C)	3	2	3	2												
Z(-40°C)/Z(+20°C)	6	4	5	4												
Load Life	The following specifications shall be satisfied when the capacitors are restored to 20°C after the rated voltage is applied at 125°C. Capacitance change ≤ ±30% of the initial value Tan δ ≤ 300% of the initial specified value Leakage current ≤ The initial specified value <table border="1"> <tr> <td>∅D</td> <td>10~50V</td> <td>63~80V</td> </tr> <tr> <td>8∅</td> <td>2,000</td> <td>-</td> </tr> <tr> <td>10∅~</td> <td>4,000</td> <td>5,000</td> </tr> </table>	∅D	10~50V	63~80V	8∅	2,000	-	10∅~	4,000	5,000						
∅D	10~50V	63~80V														
8∅	2,000	-														
10∅~	4,000	5,000														
Shelf Life	The following specifications shall be satisfied when the capacitors are restored to 20°C after exposing them for 1,000 hours at 125°C without voltage applied. The rated voltage shall be applied to the capacitors for a minimum of 30 minutes, at least 24 hours and not more than 48 hours before the measurements. Capacitance change ≤ ±30% of the initial value Tan δ ≤ 300% of the initial specified value Leakage current ≤ The initial specified value															
Others	Satisfied characteristics KS C IEC 60384-4															

DIMENSIONS OF PXD Series

Unit(mm)

Marking : GREEN SLEEVE, BLACK INK

∅D	8	10	12.5	16	18
∅d	0.6	0.6	0.6	0.8	0.8
F	3.5	5.0	5.0	7.5	7.5
∅D'	∅D + 0.5 max.				
L'	L+1.5max		L+2.0max.		

RATINGS OF PXD Series

V _{DC}		10			16			25				
Item μF	∅ D × L (mm)	Imp. (∅ max./100kHz)		Rated Ripple Current (mArms) (125°C, 100kHz)	∅ D × L (mm)	Imp. (∅ max./100kHz)		Rated Ripple Current (mArms) (125°C, 100kHz)	∅ D × L (mm)	Imp. (∅ max./100kHz)		Rated Ripple Current (mArms) (125°C, 100kHz)
		20°C	-40°C			20°C	-40°C			20°C	-40°C	
100					8 × 11.5	0.24	3.6	400				
220	8 × 11.5	0.24	3.6	400	10 × 12.5	0.11	1.1	720	10 × 12.5	0.11	1.1	720
330	10 × 12.5	0.11	1.1	720	10 × 12.5	0.11	1.1	720	10 × 16	0.071	0.71	950
470	10 × 12.5	0.11	1.1	720	10 × 16	0.071	0.71	950	10 × 20	0.056	0.56	1,100
1,000	10 × 20	0.056	0.56	1,100	12.5 × 20	0.044	0.31	1,250	12.5 × 25	0.030	0.21	1,550
2,200	12.5 × 25	0.030	0.21	1,550	16 × 25	0.023	0.16	2,000	16 × 31.5	0.019	0.13	2,500
3,300	16 × 25	0.023	0.16	2,000	16 × 31.5	0.019	0.13	2,500				
4,700	16 × 31.5	0.019	0.13	2,500								

V _{DC}		35			50			63				
Item μF	∅ D × L (mm)	Imp. (∅ max./100kHz)		Rated Ripple Current (mArms) (125°C, 100kHz)	∅ D × L (mm)	Imp. (∅ max./100kHz)		Rated Ripple Current (mArms) (125°C, 100kHz)	∅ D × L (mm)	Imp. (∅ max./100kHz)		Rated Ripple Current (mArms) (125°C, 100kHz)
		20°C	-40°C			20°C	-40°C			20°C	-40°C	
10					8 × 11.5	0.30	4.5	230				
22					8 × 11.5	0.30	4.5	320				
33					8 × 11.5	0.30	4.5	340				
47					8 × 11.5	0.30	4.5	340				
100	8 × 11.5	0.24	3.60	400	10 × 12.5	0.18	1.5	590				
	10 × 12.5	0.11	1.10	720								
220	10 × 16	0.071	0.71	950	10 × 20	0.074	0.74	950	12.5 × 20	0.19	1.5	950
330	10 × 20	0.056	0.56	1,100	12.5 × 20	0.061	0.43	1,150	12.5 × 25	0.15	1.2	1,450
470	12.5 × 20	0.044	0.31	1,250	12.5 × 25	0.040	0.28	1,400	12.5 × 30	0.090	0.71	1,700
1,000	16 × 25	0.023	0.16	2,000	16 × 31.5	0.028	0.15	2,200	16 × 31.5	0.058	0.46	2,100

V _{DC}		80		
Item μF	∅ D × L (mm)	Imp. (∅ max./100kHz)		Rated Ripple Current (mArms) (125°C, 100kHz)
		20°C	-40°C	
220	12.5 × 25	0.15	1.2	1,450
330	12.5 × 30	0.090	0.71	1,700
	16 × 20	0.085	0.58	1,790
470	12.5 × 35	0.070	0.55	2,000
	16 × 25	0.061	0.48	2,030
560	18 × 25	0.049	0.34	2,280
680	18 × 30	0.041	0.26	2,580
820	18 × 35.5	0.035	0.21	2,890

RATED RIPPLE CURRENT MULTIPLIERS

Frequency Multipliers

Freq.(Hz) Cap.(μF)	120	1k	10k	50k	100k
10 ~ 100	0.40	0.75	0.90	0.93	1.00
220 ~ 470	0.50	0.85	0.94	0.96	1.00
1,000	0.60	0.87	0.95	0.97	1.00
2,200 ~ 3,300	0.75	0.90	0.95	0.97	1.00
4,700	0.85	0.95	0.98	0.99	1.00

PFA Series

• 135°C 2,000Hrs assured.

Solvent-proof

- Low ESR.
- Wide Temperature range.
- Suitable to fit for automotive equipment.
- RoHS compliant.
- Halogen-free capacitors are also available.
- AEC-Q200 compliant : Please contact us for more details, test data, information.

PXD

PFA

Wide Temp.

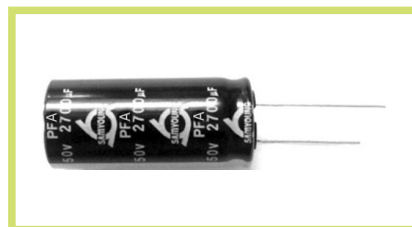

SPECIFICATIONS

Item	Characteristics															
Rated Voltage Range	10 ~ 100 V _{DC}															
Operating Temperature Range	-40 ~ +135°C															
Capacitance Tolerance	±20%(M) (at 20°C, 120Hz)															
Leakage Current	I = 0.03CV (μA) or 4μA, whichever is greater. Where, I:Max. Leakage current(μA),C:Nominal capacitance(μF),V:Rated voltage(V _{DC}) (at 20°C, 1 minute)															
Dissipation Factor(Tan δ)	<table border="1"> <tr> <td>Rated Voltage(V_{DC})</td> <td>10</td> <td>16</td> <td>25</td> <td>35</td> <td>50~63</td> <td>80~100</td> </tr> <tr> <td>Tan δ(Max.)</td> <td>0.20</td> <td>0.16</td> <td>0.14</td> <td>0.12</td> <td>0.10</td> <td>0.08</td> </tr> </table> <p>When the capacitance exceeds 1,000μF, 0.02 shall be added every 1,000μF increase. (at 20°C, 120Hz)</p>	Rated Voltage(V _{DC})	10	16	25	35	50~63	80~100	Tan δ(Max.)	0.20	0.16	0.14	0.12	0.10	0.08	
Rated Voltage(V _{DC})	10	16	25	35	50~63	80~100										
Tan δ(Max.)	0.20	0.16	0.14	0.12	0.10	0.08										
Temperature Characteristics (Max. Impedance ratio)	<table border="1"> <tr> <td>Rated Voltage(V_{DC})</td> <td>10</td> <td>16~35</td> <td>50~80</td> <td>100</td> </tr> <tr> <td>Z(-25°C)/Z(20°C)</td> <td>3</td> <td>2</td> <td>3</td> <td>3</td> </tr> <tr> <td>Z(-40°C)/Z(20°C)</td> <td>6</td> <td>4</td> <td>5</td> <td>6</td> </tr> </table> <p>(at 120Hz)</p>	Rated Voltage(V _{DC})	10	16~35	50~80	100	Z(-25°C)/Z(20°C)	3	2	3	3	Z(-40°C)/Z(20°C)	6	4	5	6
Rated Voltage(V _{DC})	10	16~35	50~80	100												
Z(-25°C)/Z(20°C)	3	2	3	3												
Z(-40°C)/Z(20°C)	6	4	5	6												
Load Life	The following specifications shall be satisfied when the capacitors are restored to 20°C after the rated voltage with the rated ripple current is applied for 2,000 hours at 135°C. Capacitance change ≤ ±30% of the initial value Tan δ ≤ 300% of the initial specified value Leakage Current ≤ The initial specified value															
Shelf Life	The following specifications shall be satisfied when the capacitors are restored to 20°C after exposing them for 1,000 hours at 135°C without voltage applied. The rated voltage shall be applied to the capacitors for a minimum of 30 minutes, at least 24 hours and not more than 48 hours before the measurements. Capacitance change ≤ ±30% of the initial value Tan δ ≤ 300% of the initial specified value Leakage current ≤ The initial specified value															
Others	Satisfied characteristics KS C IEC 60384-4															

DIMENSIONS OF PFA Series

Unit(mm)

Marking : BLACK SLEEVE, WHITE INK

øD	12.5	16	18
ød	0.6	0.8	0.8
F	5.0	7.5	7.5
øD'	øD + 0.5 max.		
L'	L + 2.0max.		

RATINGS OF PFA Series

V _{dc} ∅ D×L(mm)	10				16				25			
	μF	ESR (Ω max./100kHz)		Rated Ripple Current (mArms) (135°C, 100kHz)	μF	ESR (Ω max./100kHz)		Rated Ripple Current (mArms) (135°C, 100kHz)	μF	ESR (Ω max./100kHz)		Rated Ripple Current (mArms) (135°C, 100kHz)
		20°C	-40°C			20°C	-40°C			20°C	-40°C	
12.5×20	2,400	0.045	0.51	1,220	1,700	0.045	0.51	1,220	1,500	0.045	0.51	1,220
12.5×25	3,000	0.041	0.37	1,540	2,100	0.041	0.37	1,540	1,900	0.041	0.37	1,540
12.5×35	4,500	0.032	0.27	2,720	3,100	0.032	0.27	2,720	2,700	0.032	0.27	2,720
12.5×40	5,500	0.027	0.21	3,000	3,800	0.027	0.21	3,000	3,300	0.027	0.21	3,000
16×20	4,100	0.038	0.29	1,390	2,900	0.038	0.29	1,390	2,200	0.038	0.29	1,390
16×25	5,400	0.031	0.24	2,400	3,700	0.031	0.24	2,400	3,300	0.031	0.24	2,400
16×35.5	8,300	0.023	0.16	3,160	5,700	0.023	0.16	3,160	4,700	0.023	0.16	3,160
16×40	9,500	0.022	0.14	3,460	6,600	0.022	0.14	3,460	5,600	0.022	0.14	3,460
18×20	5,600	0.037	0.24	1,400	3,900	0.037	0.24	1,400	3,300	0.037	0.24	1,400
18×25	5,200	0.030	0.21	2,430	5,700	0.030	0.21	2,430	4,700	0.030	0.21	2,430
18×35.5	11,000	0.022	0.14	3,280	7,800	0.022	0.14	3,280	6,800	0.022	0.14	3,280
18×40	14,000	0.021	0.12	3,610	9,600	0.021	0.12	3,610	8,200	0.021	0.12	3,610

V _{dc} ∅ D×L(mm)	35				50				63			
	μF	ESR (Ω max./100kHz)		Rated Ripple Current (mArms) (135°C, 100kHz)	μF	ESR (Ω max./100kHz)		Rated Ripple Current (mArms) (135°C, 100kHz)	μF	ESR (Ω max./100kHz)		Rated Ripple Current (mArms) (135°C, 100kHz)
		20°C	-40°C			20°C	-40°C			20°C	-40°C	
12.5×20	1,000	0.045	0.51	1,220	560	0.073	0.88	1,000	330	0.110	1.33	900
12.5×25	1,200	0.041	0.37	1,540	680	0.066	0.76	1,790	470	0.100	1.16	1,611
12.5×35	1,800	0.032	0.27	2,720	1,000	0.049	0.51	2,310	680	0.083	0.87	2,079
12.5×40	2,200	0.027	0.21	3,000	1,200	0.040	0.39	2,550	820	0.068	0.66	2,295
16×20	1,500	0.038	0.29	1,390	820	0.053	0.58	1,400	560	0.090	0.99	1,260
16×25	1,800	0.031	0.24	2,400	1,200	0.045	0.47	2,030	820	0.077	0.80	1,827
16×35.5	2,700	0.023	0.16	3,160	1,800	0.030	0.28	2,690	1,200	0.054	0.47	2,421
16×40	3,300	0.022	0.14	3,460	2,200	0.032	0.28	2,950	1,500	0.051	0.48	2,655
18×20	1,800	0.038	0.25	1,400	1,000	0.046	0.48	1,640	680	0.078	0.82	1,476
18×25	2,400	0.030	0.21	2,430	1,500	0.036	0.35	2,060	1,000	0.061	0.59	1,854
18×35.5	3,900	0.022	0.14	3,280	2,200	0.027	0.23	2,920	1,500	0.046	0.38	2,628
18×40	4,700	0.021	0.12	3,610	2,700	0.026	0.18	3,230	1,800	0.044	0.31	2,907

V _{dc} ∅ D×L(mm)	80				100			
	μF	ESR (Ω max./100kHz)		Rated Ripple Current (mArms) (135°C, 100kHz)	μF	ESR (Ω max./100kHz)		Rated Ripple Current (mArms) (135°C, 100kHz)
		20°C	-40°C			20°C	-40°C	
12.5×20	220	0.120	1.45	800	150	0.120	1.45	800
12.5×25	330	0.105	1.21	1,432	180	0.105	1.21	1,432
12.5×35	470	0.088	0.92	1,848	330	0.088	0.92	1,848
12.5×40	560	0.072	0.70	2,040	390	0.072	0.70	2,040
16×20	390	0.095	1.05	1,120	270	0.095	1.05	1,120
16×25	560	0.081	0.85	1,624	330	0.081	0.85	1,624
16×35.5	820	0.058	0.50	2,152	470	0.058	0.50	2,152
16×40	1,000	0.054	0.51	2,360	680	0.054	0.51	2,360
18×20	520	0.083	0.87	1,312	330	0.083	0.87	1,312
18×25	680	0.065	0.63	1,648	470	0.065	0.63	1,648
18×35.5	1,000	0.049	0.41	2,336	760	0.049	0.41	2,336
18×40	1,200	0.047	0.33	2,584	820	0.047	0.33	2,584

RATED RIPPLE CURRENT MULTIPLIERS

Frequency Multipliers

Freq.(Hz) Cap.(μF)	120	1k	10k	50k	100k
180~2,100	0.40	0.75	0.90	0.93	1.00
2,200~3,900	0.50	0.90	0.95	0.96	1.00
4,100~14,000	0.85	0.95	0.98	0.99	1.00

PFD Series

• 135°C 2,000Hrs, 125°C 5,000Hrs assured.

- Low ESR.
- Wide Temperature range.
- Suitable to fit for automotive equipment.
- RoHS compliant.
- Halogen-free capacitors are also available.

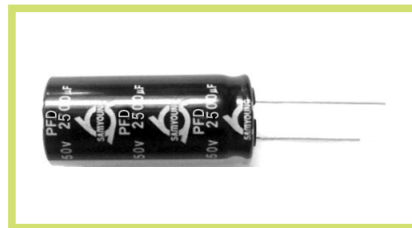

SPECIFICATIONS

Item	Characteristics						
Rated Voltage Range	50 ~ 80 V _{dc}						
Operating Temperature Range	-40 ~ +135°C						
Capacitance Tolerance	±20%(M) (at 20°C, 120Hz)						
Leakage Current	I = 0.03CV (μA) or 4μA, whichever is greater. Where, I:Max. Leakage current(μA),C:Nominal capacitance(μF),V:Rated voltage(V _{dc}) (at 20°C, 1 minute)						
Dissipation Factor(Tanδ)	<table border="1"> <tr> <td>Rated Voltage(V_{dc})</td> <td>50~80</td> </tr> <tr> <td>Tanδ(Max.)</td> <td>0.10</td> </tr> </table> <p>When the capacitance exceeds 1,000μF, 0.02 shall be added every 1,000μF increase. (at 20°C, 120Hz)</p>	Rated Voltage(V _{dc})	50~80	Tanδ(Max.)	0.10		
Rated Voltage(V _{dc})	50~80						
Tanδ(Max.)	0.10						
Temperature Characteristics (Max. Impedance ratio)	<table border="1"> <tr> <td>Rated Voltage(VDC)</td> <td>50~80</td> </tr> <tr> <td>Z(-25°C)/Z(+20°C)</td> <td>3</td> </tr> <tr> <td>Z(-40°C)/Z(+20°C)</td> <td>6</td> </tr> </table> <p>(at 120Hz)</p>	Rated Voltage(VDC)	50~80	Z(-25°C)/Z(+20°C)	3	Z(-40°C)/Z(+20°C)	6
Rated Voltage(VDC)	50~80						
Z(-25°C)/Z(+20°C)	3						
Z(-40°C)/Z(+20°C)	6						
Load Life	<p>The following specifications shall be satisfied when the capacitors are restored to 20°C after the rated voltage with the rated ripple current is applied (the peak voltage shall not exceed the rated voltage) for 2,000 hours at 135°C, 5,000 hours at 125°C.</p> <p>Capacitance change ≤ ±30% of the initial value Tanδ ≤ 300% of the initial specified value Leakage Current ≤ The initial specified value</p>						
Shelf Life	<p>The following specifications shall be satisfied when the capacitors are restored to 20°C after exposing for 1,000 hours at 135°C, 125°C without voltage applied. The rated voltage shall be applied to the capacitors for a minimum of 30 minutes, at least 24 hours and not more than 48 hours before the measurements.</p> <p>Capacitance change ≤ ±30% of the initial value Tanδ ≤ 300% of the initial specified value Leakage current ≤ The initial specified value</p>						
Others	Satisfied characteristics KS C IEC 60384-4						

DIMENSIONS OF PFD Series

Unit(mm)

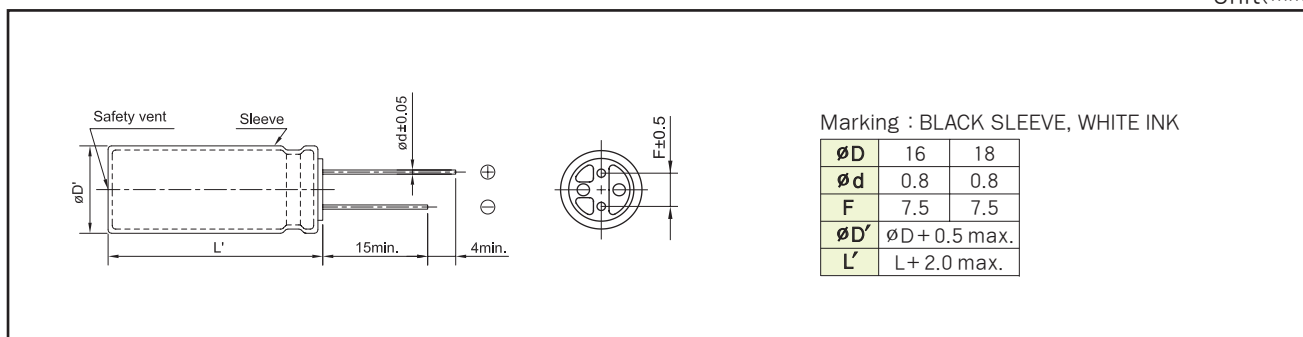

RATINGS OF PFD Series

Vdc	Capacitance (μF)	$\varnothing D \times L$ (mm)	ESR (Ω max./100kHz)		Rated Ripple Current (mA rms/125°C, 100%)	Rated Ripple Current (mA rms/135°C, 100%)
			20°C	-40°C		
50	1000	16 x 20	0.050	0.550	2960	1870
	1300	16 x 25	0.042	0.440	4040	2500
		18 x 20	0.042	0.440	3130	2110
	1600	16 x 31.5	0.035	0.360	5130	2960
	1800	18 x 25	0.033	0.320	4230	2530
	2200	16 x 35.5	0.029	0.270	5480	3160
	2400	18 x 31.5	0.028	0.250	5240	3020
	2500	16 x 40	0.025	0.220	5930	3420
63	3000	18 x 35.5	0.024	0.200	5870	3390
	3600	18 x 40	0.023	0.160	6420	3700
	680	16 x 20	0.053	0.340	2140	1910
	820	16 x 25	0.038	0.230	2940	2680
	910	18 x 20	0.044	0.260	2350	2100
	1200	16 x 31.5	0.034	0.200	3860	3050
		18 x 25	0.033	0.190	3080	2810
	1400	16 x 35.5	0.027	0.150	4590	3420
1600	16 x 40	0.025	0.140	5190	3670	
	18 x 31.5	0.028	0.150	4080	3220	
2000	18 x 35.5	0.022	0.120	5220	3690	
2300	18 x 40	0.021	0.110	5660	3820	
80	470	16 x 20	0.053	0.340	2140	1910
	620	18 x 20	0.044	0.260	2350	2100
	680	16 x 25	0.038	0.230	2940	2680
	820	16 x 31.5	0.034	0.200	3860	3050
		18 x 25	0.033	0.190	3080	2810
	1000	16 x 35.5	0.027	0.150	4590	3420
	1200	18 x 31.5	0.028	0.150	4080	3220
	1300	16 x 40	0.025	0.140	5190	3670
18 x 35.5		0.022	0.120	5220	3690	
1600	18 x 40	0.021	0.110	5660	3820	

RATED RIPPLE CURRENT MULTIPLIERS

Frequency Multipliers

Freq.(Hz) Cap.(μF)	120	1k	10k	50k	100k
470~910	0.50	0.85	0.94	0.96	1.00
1,000~2,000	0.60	0.87	0.95	0.97	1.00
2200~4,300	0.75	0.90	0.95	0.97	1.00
4700~12,000	0.85	0.95	0.98	0.99	1.00

PFB Series

• 130°C 8,000~10,000Hrs assured.

- Non-solvent proof
- Wide Temperature range.
- Long Life.
- Applicable to compact sized Adaptor for TV power
- RoHS compliant.
- Halogen-free capacitors are also available.

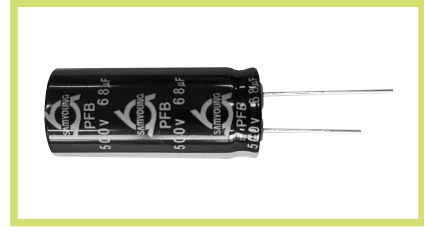
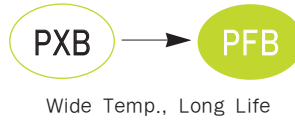

SPECIFICATIONS

Item	Characteristics											
Rated Voltage Range	400 ~ 500 V _{DC}											
Operating Temperature Range	-25 ~ +130°C											
Capacitance Tolerance	±20%(M) (at 20°C, 120Hz)											
Leakage Current	<table border="1"> <thead> <tr> <th>CV</th> <th>Time</th> <th>After 1 minute</th> <th>After 5 minutes</th> </tr> </thead> <tbody> <tr> <td rowspan="2">≤ 1000</td> <td></td> <td>I=0.1CV+40</td> <td>I=0.03CV+15</td> </tr> <tr> <td>> 1000</td> <td>I=0.04CV+100</td> <td>I=0.02CV+25</td> </tr> </tbody> </table> <p>Where, I: Max. Leakage current(μA), C: Nominal capacitance(μF), V: Rated voltage(V_{DC}) (at 20°C)</p>	CV	Time	After 1 minute	After 5 minutes	≤ 1000		I=0.1CV+40	I=0.03CV+15	> 1000	I=0.04CV+100	I=0.02CV+25
CV	Time	After 1 minute	After 5 minutes									
≤ 1000		I=0.1CV+40	I=0.03CV+15									
	> 1000	I=0.04CV+100	I=0.02CV+25									
Dissipation Factor(Tanδ)	<table border="1"> <thead> <tr> <th>Rated Voltage(V_{DC})</th> <th>400</th> <th>420 ~ 500</th> </tr> </thead> <tbody> <tr> <td>Tanδ(Max.)</td> <td>0.20</td> <td>0.24</td> </tr> </tbody> </table> <p>(at 20°C, 120Hz)</p>	Rated Voltage(V _{DC})	400	420 ~ 500	Tanδ(Max.)	0.20	0.24					
Rated Voltage(V _{DC})	400	420 ~ 500										
Tanδ(Max.)	0.20	0.24										
Temperature Characteristics (Max. Impedance ratio)	<table border="1"> <thead> <tr> <th>Rated Voltage(V_{DC})</th> <th>400 ~ 500</th> </tr> </thead> <tbody> <tr> <td>Z(-25°C)/Z(+20°C)</td> <td>6</td> </tr> </tbody> </table> <p>(at 120Hz)</p>	Rated Voltage(V _{DC})	400 ~ 500	Z(-25°C)/Z(+20°C)	6							
Rated Voltage(V _{DC})	400 ~ 500											
Z(-25°C)/Z(+20°C)	6											
Load Life	<p>The following specifications shall be satisfied when the capacitors are restored to 20°C after the rated voltage with the rated ripple current is applied(the peak voltage shall not exceed the rated voltage) for 10,000 hours at 130°C(Where 8,000 hours for ø10, ø12.5)</p> <p>Capacitance change ≤ ±30% of the initial value Tanδ ≤ 300% of the initial specified value Leakage Current ≤ The initial specified value</p>											
Shelf Life	<p>The following specifications shall be satisfied when the capacitors are restored to 20°C after exposing them for 1,000 hours at 130°C without voltage applied. The rated voltage shall be applied to the capacitors for a minimum of 30 minutes, at least 24 hours and not more than 48 hours before the measurements.</p> <p>Capacitance change ≤ ±30% of the initial value Tanδ ≤ 300% of the initial specified value Leakage current ≤ 500% of the initial specified value</p>											
Others	Satisfied characteristics KS C IEC 60384-4											

DIMENSIONS OF PFB Series

Unit(mm)

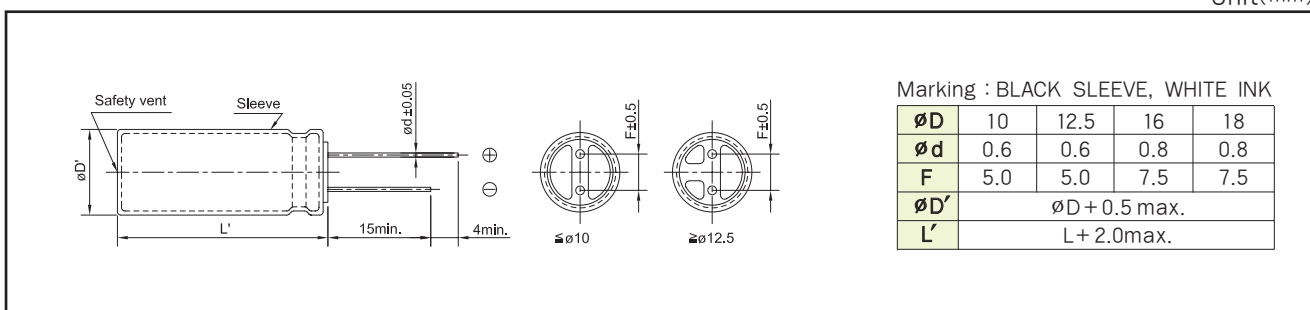

RATINGS OF PFB Series

V _{dc} ∅ D × L (mm)	400		420	
	μF	Rated Ripple Current (mArms/130°C, 120Hz)	μF	Rated Ripple Current (mArms/130°C, 120Hz)
10 × 50	33	230	33	210
12.5 × 50	56	330	56	310
12.5 × 60	68	390	68	360
16 × 20	27	180	27	170
16 × 25	39	240	39	220
16 × 31.5	56	310	56	290
16 × 35.5	68	350	68	330
16 × 40	68	370	68	350
16 × 45	82	420	82	400
16 × 50	100	490	100	460
18 × 20	39	230	39	220
18 × 25	56	300	56	280
18 × 31.5	82	390	82	370
18 × 35.5	82	410	82	390
18 × 40	100	470	100	450
18 × 45	120	540	120	510
18 × 50	150	630	150	590

V _{dc} ∅ D × L (mm)	450		500	
	μF	Rated Ripple Current (mArms/130°C, 120Hz)	μF	Rated Ripple Current (mArms/130°C, 120Hz)
10 × 50	27	160	22	140
12.5 × 50	47	230	39	210
12.5 × 60	56	270	47	250
16 × 20	22	120	18	110
16 × 25	33	170	22	130
16 × 31.5	39	200	33	180
16 × 35.5	47	230	39	210
16 × 40	56	260	47	240
16 × 45	68	300	53	260
16 × 50	82	340	56	280
18 × 20	27	150	22	130
18 × 25	39	190	33	180
18 × 31.5	56	250	47	230
18 × 35.5	68	290	53	250
18 × 40	82	330	56	270
18 × 45	82	350	68	310
18 × 50	100	400	82	360

RATED RIPPLE CURRENT MULTIPLIERS

Frequency Multipliers

Freq.(Hz)	120	1k	10k	50k	100k
Cap.(μF) 18~150	1.00	1.30	1.40	1.43	1.50

PHA Series

• 150°C 2,000Hrs assured.

Solvent-proof

- Wide Temperature range.
- Suitable to fit for automotive equipment.
- RoHS compliant.
- Halogen-free capacitors are also available.

PXA

PHA

Wide Temp.

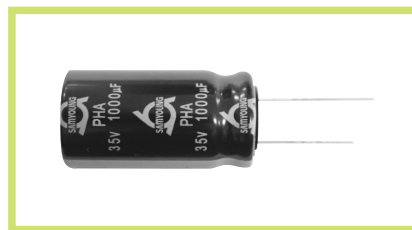

SPECIFICATIONS

Item	Characteristics												
Rated Voltage Range	10 ~ 50 V _{dc}												
Operating Temperature Range	-40 ~ +150°C												
Capacitance Tolerance	±20%(M) (at 20°C, 120Hz)												
Leakage Current	I = 0.03CV (μA) or 4μA, whichever is greater. Where, I:Max. Leakage current(μA), C:Nominal capacitance(μF), V:Rated voltage(V _{dc}) (at 20°C, 1 minute)												
Dissipation Factor(Tanδ)	<table border="1"> <thead> <tr> <th>Rated Voltage(V_{dc})</th> <th>10</th> <th>16</th> <th>25</th> <th>35</th> <th>50</th> </tr> </thead> <tbody> <tr> <td>Tanδ(Max.)</td> <td>0.24</td> <td>0.20</td> <td>0.16</td> <td>0.14</td> <td>0.12</td> </tr> </tbody> </table> (at 20°C,120Hz)	Rated Voltage(V _{dc})	10	16	25	35	50	Tanδ(Max.)	0.24	0.20	0.16	0.14	0.12
Rated Voltage(V _{dc})	10	16	25	35	50								
Tanδ(Max.)	0.24	0.20	0.16	0.14	0.12								
Temperature Characteristics (Max. impedance ratio)	<table border="1"> <thead> <tr> <th>Rate Voltage(V_{dc})</th> <th>10 ~ 50</th> </tr> </thead> <tbody> <tr> <td>Z(-25°C)/Z(+20°C)</td> <td>2</td> </tr> <tr> <td>Z(-40°C)/Z(+20°C)</td> <td>4</td> </tr> </tbody> </table> (at 120Hz)	Rate Voltage(V _{dc})	10 ~ 50	Z(-25°C)/Z(+20°C)	2	Z(-40°C)/Z(+20°C)	4						
Rate Voltage(V _{dc})	10 ~ 50												
Z(-25°C)/Z(+20°C)	2												
Z(-40°C)/Z(+20°C)	4												
Load Life	The following specifications shall be satisfied when the capacitors are restored to 20°C after the rated voltage is applied at 150°C for 2,000 hours. Capacitance change ≤ ±30% of the initial value Tanδ ≤ 300% of the initial specified value Leakage Current ≤ The initial specified value												
Shelf Life	The following specifications shall be satisfied when the capacitors are restored to 20°C after exposing them for 1,000 hours at 150°C without voltage applied. The rated voltage shall be applied to the capacitors for a minimum of 30 minutes, at least 24 hours and not more than 48 hours before the measurements. Capacitance change ≤ ±30% of the initial value Tanδ ≤ 300% of the initial specified value Leakage Current ≤ The initial specified value												
Others	Satisfied characteristics KS C IEC 60384-4												

DIMENSIONS OF PHA Series

Unit(mm)

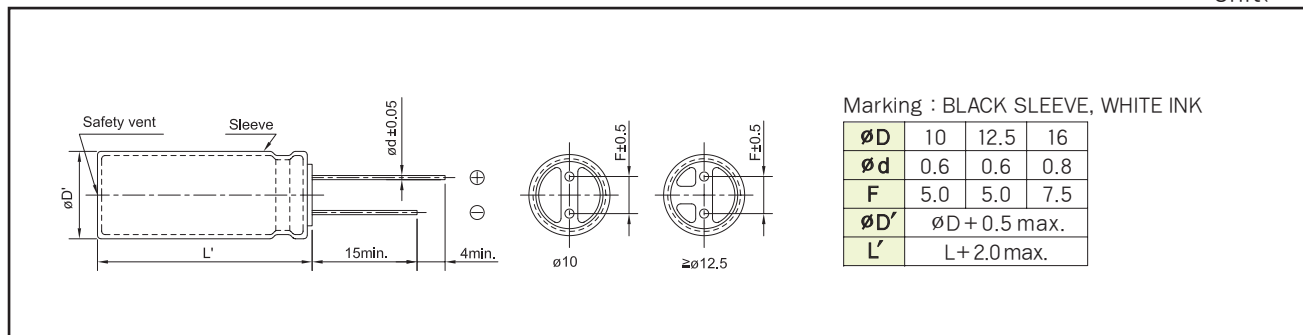

RATINGS OF PHA Series

V _{bc}	10		16		25	
Items μF	∅D×L(mm)	Rated Ripple Current (mArms/150°C,120Hz)	∅D×L(mm)	Rated Ripple Current (mArms/150°C,120Hz)	∅D×L(mm)	Rated Ripple Current (mArms/150°C,120Hz)
220					10×16	370
330			10×16	370	12.5×20	600
470	10×16	370	12.5×20	600	16×31.5	1,100
1,000	12.5×20	600	16×31.5	1,100	16×35.5	1,150
2,200	16×31.5	1,100	16×35.5	1,150		
3,300	16×35.5	1,150				

V _{bc}	35		50	
Items μF	∅D×L(mm)	Rated Ripple Current (mArms/150°C,120Hz)	∅D×L(mm)	Rated Ripple Current (mArms/150°C,120Hz)
100	10×16	370	10×20	300
220	10×20	460	12.5×20	400
330	12.5×20	600	12.5×25	500
470	12.5×25	750	16×35.5	700
1,000	16×35.5	1,150		

RATED RIPPLE CURRENT MULTIPLIERS

Frequency Multipliers

Cap.(μF) \ Freq.(Hz)	120	1k	10k	50k	100k
100 ~ 1,000	1.00	1.15	1.30	1.33	1.40
2,200 ~ 3,300	1.00	1.03	1.05	1.06	1.08

AHS Series

• 85°C 2,000Hrs assured.

- Non-solvent proof.
- For Hi-Fi Audio.
- RoHS compliant.
- Halogen-free capacitors are also available.



SPECIFICATIONS

Item	Characteristics																
Rated Voltage Range	10 ~ 100 V _{DC}																
Operating Temperature Range	-40 ~ +85°C																
Capacitance Tolerance	±20%(M) (at 20°C, 120Hz)																
Leakage Current	I = 0.03CV (μA) or 4μA whichever is greater. Where, I: Max. Leakage current(μA) C: Nominal capacitance (μF) V: Rated Voltage (V _{DC}) (at 20°C, 1 minute)																
Dissipation Factor(Tanδ)	<table border="1"> <tr> <td>Rated Voltage(V_{DC})</td> <td>10</td> <td>16</td> <td>25</td> <td>35</td> <td>50</td> <td>63</td> <td>100</td> </tr> <tr> <td>Tanδ(Max.)</td> <td>0.19</td> <td>0.16</td> <td>0.14</td> <td>0.12</td> <td>0.10</td> <td>0.09</td> <td>0.08</td> </tr> </table> <p>When the capacitance exceeds 1,000μF, 0.02 shall be added every 1,000μF increase. (at 20°C, 120Hz)</p>	Rated Voltage(V _{DC})	10	16	25	35	50	63	100	Tanδ(Max.)	0.19	0.16	0.14	0.12	0.10	0.09	0.08
Rated Voltage(V _{DC})	10	16	25	35	50	63	100										
Tanδ(Max.)	0.19	0.16	0.14	0.12	0.10	0.09	0.08										
Temperature Characteristics (Max. Impedance ratio)	<table border="1"> <tr> <td>Rated Voltage(V_{DC})</td> <td>10</td> <td>16</td> <td>25</td> <td>35~100</td> </tr> <tr> <td>Z(-25°C)/Z(20°C)</td> <td>3</td> <td>2</td> <td>2</td> <td>2</td> </tr> <tr> <td>Z(-40°C)/Z(20°C)</td> <td>8</td> <td>6</td> <td>4</td> <td>3</td> </tr> </table> <p>(at 120Hz)</p>	Rated Voltage(V _{DC})	10	16	25	35~100	Z(-25°C)/Z(20°C)	3	2	2	2	Z(-40°C)/Z(20°C)	8	6	4	3	
Rated Voltage(V _{DC})	10	16	25	35~100													
Z(-25°C)/Z(20°C)	3	2	2	2													
Z(-40°C)/Z(20°C)	8	6	4	3													
Load Life	<p>The following specifications shall be satisfied when the capacitors are restored to 20°C after the rated voltage is applied for 2,000 hours at 85°C.</p> <p>Capacitance change ≤ ±20% of the initial value Tanδ ≤ 200% of the initial specified value Leakage current ≤ The initial specified value</p>																
Shelf Life	<p>The following specifications shall be satisfied when the capacitors are restored to 20°C after exposing them at 85°C. for 1,000 hours without voltage applied. The rated voltage shall be applied to the capacitors for a minimum of 30 minutes, at least 24 hours and not more than 48 hours before the measurements.</p> <p>Capacitance change ≤ ±20% of the initial value Tanδ ≤ 200% of the initial specified value Leakage current ≤ The initial specified value</p>																
Others	Satisfied characteristics KS C IEC 60384-4																

DIMENSIONS OF AHS Series

Unit(mm)

Marking : DARK BROWN SLEEVE, GOLD INK

øD	5	6.3	8	10	12.5	16	18
ød	0.5	0.5	0.6	0.6	0.8	0.8	0.8
F	2.0	2.5	3.5	5.0	5.0	7.5	7.5
øD'	øD + 0.5 max.						
L'	L + 1.5 max.			L + 2.0 max.			

RATINGS OF AHS Series

μF \ V _{DC}	10		16		25		35		50	
	1									5×11
2.2									5×11	21
3.3									5×11	26
4.7							5×11	28	5×11	31
10					5×11	39	5×11	41	5×11	45
22	5×11	49	5×11	54	5×11	58	5×11	61	5×11	66
33	5×11	59	5×11	66	5×11	70	5×11	75	6.3×11	93
47	5×11	71	5×11	78	5×11	84	6.3×11	103	6.3×11	111
100	5×11	103	6.3×11	132	6.3×11	140	8×11.5	171	8×11.5	185
220	6.3×11	177	8×11.5	224	8×11.5	237	10×12.5	299	10×16	357
330	8×11.5	248	8×11.5	274	10×12.5	343	10×16	404	10×20	473
470	8×11.5	296	10×12.5	386	10×16	451	10×20	523	12.5×20	626
1,000	10×16	538	10×20	638	12.5×20	746	12.5×25	860	16×25	1,017
2,200	12.5×20	920	12.5×25	1,087	16×25	1,262	16×31.5	1,413	18×35.5	1,621
3,300	12.5×25	1,180	16×25	1,411	16×31.5	1,586	18×35.5	1,776		
4,700	16×25	1,458	16×31.5	1,678	18×35.5	2,120				
6,800	16×31.5	1,780	18×35.5	2,016						
10,000	18×35.5	2,134								

Rated Ripple Current (mA rms/85°C, 120Hz)
 Case Size $\phi D \times L$ (mm)

μF \ V _{DC}	63		100	
	1			5×11
2.2			5×11	23
3.3			5×11	28
4.7	5×11	34	5×11	34
10	5×11	49	6.3×11	56
22	6.3×11	83	8×11.5	95
33	6.3×11	102	10×12.5	137
47	8×11.5	136	10×16	181
100	10×12.5	239	12.5×20	316
220	10×20	423	16×25	564
330	12.5×20	575	16×25	691
470	12.5×25	745	16×31.5	891
1,000	16×31.5	1,182		

PHL Series

• 5~35°C 5,000Times.

- Non-solvent proof.
- For Photo Flash.
- RoHS compliant.
- Halogen-free capacitors are also available.



SPECIFICATIONS

Item	Characteristics						
Rated Voltage	300 ~ 330 V _{dc}						
Operating Temperature Range	-20 ~ +55°C						
Capacitance Tolerance	-10 ~ +20%(V) (at 20°C, 120Hz)						
Leakage Current	<table border="1"> <tr> <td>∅D(mm)</td> <td>∅5~8</td> <td>∅10~</td> </tr> <tr> <td>LC(Max.)</td> <td>I = 2.0 × C</td> <td>I = 1.0 × C</td> </tr> </table> <p>Where, I:Max.Leakage current(μA) C: Nominal capacitance (μF) (at 20°C, 5 minutes)</p>	∅D(mm)	∅5~8	∅10~	LC(Max.)	I = 2.0 × C	I = 1.0 × C
∅D(mm)	∅5~8	∅10~					
LC(Max.)	I = 2.0 × C	I = 1.0 × C					
Dissipation Factor(Tanδ)	<table border="1"> <tr> <td>∅D(mm)</td> <td>∅5~8</td> <td>∅10~</td> </tr> <tr> <td>Tanδ(Max.)</td> <td>0.085</td> <td>0.06</td> </tr> </table> <p>(at 20°C, 120Hz)</p>	∅D(mm)	∅5~8	∅10~	Tanδ(Max.)	0.085	0.06
∅D(mm)	∅5~8	∅10~					
Tanδ(Max.)	0.085	0.06					
Charge and Discharge Characteristics	<p>The following specifications shall be satisfied when the capacitors are restored to 20°C after charge and discharge are repeated 5,000 times at room temperature (5 to 35°C) Discharge resistance or Xenon tube: 0.7~1.0 Ω.</p> <p>Capacitance change ≤ ±10% of the initial value Tanδ ≤ 150% of the initial specified value Leakage current ≤ 150% of the initial specified value</p>						
Shelf Life	<p>The following specifications shall be satisfied when the capacitors are restored to 20°C after exposing them for 1000 hours at 55°C without voltage applied.</p> <p>Capacitance change ≤ ±10% of the initial value Tanδ ≤ 150% of the initial specified value Leakage current ≤ 150% of the initial specified value</p>						
Others	Satisfied characteristics EIAJ RC - 3801A						

RATINGS OF PHL Series

μF \ V _{DC}	300			315			330		
	5				5 × 16	6.3 × 10			
6.8					6.3 × 11				
10					6.3 × 15	8 × 11.5			
12.5					6.3 × 20	8 × 15			
15						8 × 17			
20						8 × 20			
30						8 × 23			
60	11.8 × 22						11.8 × 24		
80	11.8 × 27	13 × 25					11.8 × 29	13 × 27	
100	11.8 × 32	13 × 29	13.5 × 26				11.8 × 35	13 × 32 13.5 × 28	
120		13 × 34	13.5 × 30					13 × 37 13.5 × 33	
140		13 × 38	13.5 × 34					13 × 42 13.5 × 37	
160		13 × 43	13.5 × 38					13.5 × 41	

Note : Other case sizes, rated voltage or capacitance are also available upon request.

↑ Case Size ∅D × L(mm)

DIMENSIONS OF PHL Series

Unit(mm)

Marking : BLACK SLEEVE, WHITE INK

∅D	5	6.3	8	11.8	13	13.5
∅d	0.5	0.5	0.6	0.6	0.6	0.8
F	2.0	2.5	3.5	5.0	5.0	5.0
∅D'	∅D + 0.5 max.					
L'	L + 1.0 max.					

NZD Series

- 105°C 5,000Hrs assured.

Solvent-proof



- For car air bag circuit.
- RoHS compliant.
- Halogen-free capacitors are also available.
- AEC-Q200 compliant : Please contact us for more details, test data, information.

SPECIFICATIONS

Item	Characteristics						
Rated Voltage Range	25 ~ 35 V _{DC}						
Operating Temperature Range	-55 ~ +105°C						
Capacitance Tolerance	0% ~ 30%(S) (at 20°C, 120Hz)						
Leakage Current	$I = 0.01CV(\mu A)$ Where, I:Max. Leakage current(μA), C:Nominal capacitance(μF), V:Rated voltage(V _{DC}) (at 20°C, 2 minutes)						
Dissipation Factor(Tan δ)	<table border="1"> <tr> <td>Rated Voltage(V_{DC})</td> <td>25</td> <td>35</td> </tr> <tr> <td>Tanδ(Max.)</td> <td>0.14</td> <td>0.12</td> </tr> </table> When the capacitance exceeds 1,000 μF , 0.02 shall be added every 1,000 μF increase. (at 20°C, 120Hz)	Rated Voltage(V _{DC})	25	35	Tan δ (Max.)	0.14	0.12
Rated Voltage(V _{DC})	25	35					
Tan δ (Max.)	0.14	0.12					
Temperature Characteristics (Max. Impedance ratio)	<table border="1"> <tr> <td>Rated Voltage(V_{DC})</td> <td>25</td> <td>35</td> </tr> <tr> <td>Z(-55°C)/Z(20°C)</td> <td colspan="2">3</td> </tr> </table> (at 120Hz)	Rated Voltage(V _{DC})	25	35	Z(-55°C)/Z(20°C)	3	
Rated Voltage(V _{DC})	25	35					
Z(-55°C)/Z(20°C)	3						
Load Life	The following specifications shall be satisfied when the capacitors are restored to 20°C after the rated voltage with the rated ripple current is applied (the peak voltage shall not exceed the rated voltage) for 5,000 hours at 105°C. Capacitance change $\leq \pm 25\%$ of the initial value Tan δ $\leq 200\%$ of the initial specified value Leakage current \leq The initial specified value						
Shelf Life	The following specifications shall be satisfied when the capacitors are restored to 20°C after exposing them for 1,000 hours at 105°C without voltage applied. The rated voltage shall be applied to the capacitors for a minimum of 30 minutes, at least 24 hours and not more than 48 hours before the measurements. Capacitance change $\leq \pm 20\%$ of the initial value Tan δ $\leq 200\%$ of the initial specified value Leakage current \leq The initial specified value						
Others	Satisfied characteristics KS C IEC 60384-4						

DIMENSIONS OF NZD Series

Unit(mm)

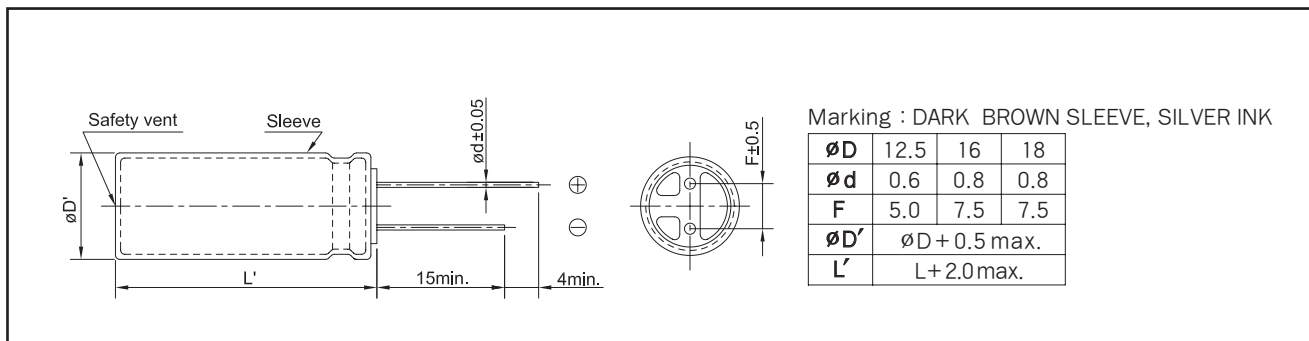

RATINGS OF NZD Series

V _{dc}	25		
μF	∅ D×L(mm)	Rated Ripple Current (mA _{rms} /105°C, 100kHz)	Impedance (Ω max./20°C, 100kHz)
1,800	12.5×20	1,700	0.055
2,400	12.5×25	2,000	0.045
3,600	16×20	2,200	0.041
4,800	18×20	2,400	0.036
5,200	16×25	2,500	0.033
6,700	18×25	2,700	0.028
	16×31.5		
8,200	16×35.5	3,050	0.026
9,200	18×31.5	3,200	0.024
	16×40		
11,000	18×35.5	3,500	0.019
13,000	18×40	3,800	0.017
15,000	18×45	4,000	0.015

V _{dc}	35		
μF	∅ D×L(mm)	Rated Ripple Current (mA _{rms} /105°C, 100kHz)	Impedance (Ω max./20°C, 100kHz)
1,100	12.5×20	1,500	0.057
1,400	12.5×25	1,700	0.054
2,100	16×20	2,000	0.047
2,700	18×20	2,250	0.042
3,300	16×25	2,400	0.037
4,200	18×25	2,550	0.033
	16×31.5		
5,200	16×35.5	2,800	0.031
6,000	18×31.5	2,950	0.029
7,100	18×35.5	3,050	0.027
8,400	18×40	3,200	0.025
9,600	18×45	3,400	0.023

RATED RIPPLE CURRENT MULTIPLIERS

Frequency Multipliers

Freq.(Hz) Cap.(μF)	120	1k	10k	100k
1,100~1,800	0.60	0.87	0.95	1.00
2,100~3,600	0.75	0.90	0.95	1.00
4,200~15,000	0.85	0.95	0.98	1.00

NZK Series

- 105°C 5,000Hrs assured.

- For car air bag circuit.
- RoHS compliant.
- Halogen-free capacitors are also available.
- AEC-Q200 compliant : Please contact us for more details, test data, information.



SPECIFICATIONS

Item	Characteristics						
Rated Voltage Range	25 ~ 35 V _{DC}						
Operating Temperature Range	-55 ~ +105°C						
Capacitance Tolerance	0% ~ 30%(S) (at 20°C, 120Hz)						
Leakage Current	$I = 0.01CV(\mu A)$ Where, I:Max. Leakage current(μA), C:Nominal capacitance(μF), V:Rated voltage(V _{DC}) (at 20°C, 2 minutes)						
Dissipation Factor(Tan δ)	<table border="1"> <tr> <td>Rated Voltage(V_{DC})</td> <td>25</td> <td>35</td> </tr> <tr> <td>Tanδ(Max.)</td> <td>0.20</td> <td>0.16</td> </tr> </table> When the capacitance exceeds 1,000 μF , 0.02 shall be added every 1,000 μF increase. (at 20°C, 120Hz)	Rated Voltage(V _{DC})	25	35	Tan δ (Max.)	0.20	0.16
Rated Voltage(V _{DC})	25	35					
Tan δ (Max.)	0.20	0.16					
Temperature Characteristics (Max. Impedance ratio)	<table border="1"> <tr> <td>Rated Voltage(V_{DC})</td> <td>25~35</td> </tr> <tr> <td>Z(-55°C)/Z(+20°C)</td> <td>3</td> </tr> </table> (at 120Hz)	Rated Voltage(V _{DC})	25~35	Z(-55°C)/Z(+20°C)	3		
Rated Voltage(V _{DC})	25~35						
Z(-55°C)/Z(+20°C)	3						
Load Life	The following specifications shall be satisfied when the capacitors are restored to 20°C after the rated voltage with the rated ripple current is applied (the peak voltage shall not exceed the rated voltage) for 5,000 hours at 105°C. Capacitance change \leq $\pm 30\%$ of the initial value Tan δ \leq 300% of the initial specified value Leakage current \leq The initial specified value						
Shelf Life	The following specifications shall be satisfied when the capacitors are restored to 20°C after exposing them for 1,000 hours at 105°C without voltage applied. The rated voltage shall be applied to the capacitors for a minimum of 30 minutes, at least 24 hours and not more than 48 hours before the measurements. Capacitance change \leq $\pm 30\%$ of the initial value Tan δ \leq 300% of the initial specified value Leakage current \leq The initial specified value						
Others	Satisfied characteristics KS C IEC 60384-4						

DIMENSIONS OF NZK Series

Unit(mm)

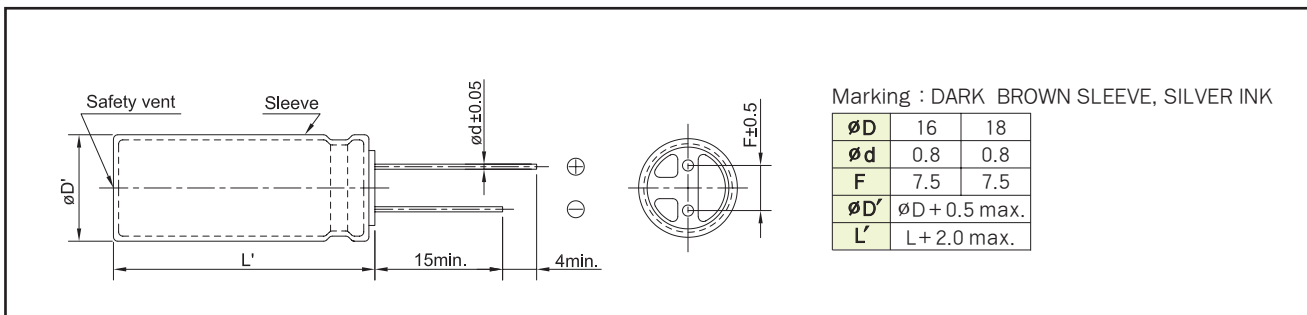

RATINGS OF NZK Series

V _{bc}	Capacitance (μF)	∅ D × L (mm)	ESR (Ω max./20°C, 100kHz)	Rated Ripple Current (mA rms/105°C, 100kHz)
25	4400	16 × 20	0.030	2200
	5700	16 × 25	0.024	2500
	5900	18 × 20	0.028	2400
	7300	16 × 31.5	0.020	2700
	7700	18 × 25	0.022	2700
	9000	16 × 35.5	0.018	3050
	10000	16 × 40	0.016	3200
	12000	18 × 35.5	0.016	3500
	14000	18 × 40	0.015	3800
35	2800	16 × 20	0.030	2000
	3600	16 × 25	0.024	2400
	3700	18 × 20	0.028	2250
	4700	16 × 31.5	0.020	2550
	4800	18 × 25	0.022	2550
	5700	16 × 35.5	0.018	2800
	6500	16 × 40	0.016	2900
	6800	18 × 31.5	0.018	2950
	7800	18 × 35.5	0.016	3050
	9000	18 × 40	0.015	3200

RATED RIPPLE CURRENT MULTIPLIERS

Frequency Multipliers

Cap. (μF) \ Freq. (Hz)	120	1k	10k	100k
2,100 ~ 3,700	0.75	0.90	0.95	1.00
4,200 ~ 15,000	0.85	0.95	0.98	1.00

NZH Series

• 105°C 2,000Hrs assured.

- Non-solvent proof
- High ripple and High surge voltage
- For LED TV Power , SMPS
- **RoHS compliant.**
- **Halogen-free capacitors are also available.**

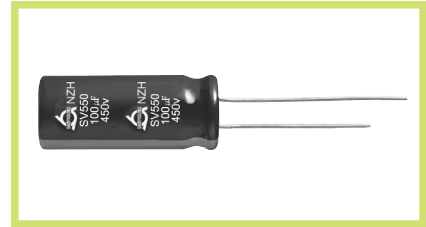

SPECIFICATIONS

Item	Characteristics											
Rated Voltage	450 V _{DC}											
Surge Voltage	550 V _{DC}											
Operating Temperature Range	-25 ~ +105°C											
Capacitance Tolerance	±20%(M) (at 20°C, 120Hz)											
Leakage Current	<table border="1"> <thead> <tr> <th>CV</th> <th>Time</th> <th>After 1 minute</th> <th>After 5 minutes</th> </tr> </thead> <tbody> <tr> <td rowspan="2">≤ 1000</td> <td></td> <td>I=0.1CV+40</td> <td>I=0.03CV+15</td> </tr> <tr> <td></td> <td>I=0.04CV+100</td> <td>I=0.02CV+25</td> </tr> </tbody> </table>	CV	Time	After 1 minute	After 5 minutes	≤ 1000		I=0.1CV+40	I=0.03CV+15		I=0.04CV+100	I=0.02CV+25
	CV	Time	After 1 minute	After 5 minutes								
	≤ 1000		I=0.1CV+40	I=0.03CV+15								
		I=0.04CV+100	I=0.02CV+25									
Where, I : Max. Leakage current(μA) C : Nominal capacitance(μF) V : Rated voltage(V _{DC}) (at 20°C)												
Dissipation Factor(Tanδ)	<table border="1"> <tr> <td>Rated Voltage(V_{DC})</td> <td>450</td> </tr> <tr> <td>Tanδ(Max.)</td> <td>0.24</td> </tr> </table>	Rated Voltage(V _{DC})	450	Tanδ(Max.)	0.24	(at 20°C, 120Hz)						
	Rated Voltage(V _{DC})	450										
Tanδ(Max.)	0.24											
Temperature Characteristics (Max. Impedance ratio)	<table border="1"> <tr> <td>Rated Voltage(V_{DC})</td> <td>450</td> </tr> <tr> <td>Z(-25°C)/Z(20°C)</td> <td>6</td> </tr> </table>	Rated Voltage(V _{DC})	450	Z(-25°C)/Z(20°C)	6	(at 120Hz)						
	Rated Voltage(V _{DC})	450										
Z(-25°C)/Z(20°C)	6											
Load Life	<p>The following specifications shall be satisfied when the capacitors are restored to 20°C after the rated voltage with the rated ripple current is applied for 2,000 hours at 105°C.</p> <p>Capacitance change ≤ ±20 % of the initial value tan δ ≤ 200 % of the initial specified value Leakage current ≤ The initial specified value</p>											
Shelf Life	<p>The following specifications shall be satisfied when the capacitors are restored to 20°C after exposing them for 1,000 hours at 105°C without voltage applied. The rated voltage shall be applied to the capacitors for a minimum of 30 minutes, at least 24 hours and not more than 48 hours before the measurements.</p> <p>Capacitance change ≤ ±20 % of the initial value tan δ ≤ 200 % of the initial specified value Leakage current ≤ 500 % of the initial specified value</p>											
Others	Satisfied characteristics KS C IEC 60384-4											

DIMENSIONS OF NZH Series

Unit(mm)

Marking : DARK BLUE SLEEVE, SILVER INK

øD	8	10	12.5	16	18
ød	0.6	0.6	0.6	0.8	0.8
F	3.5	5.0	5.0	7.5	7.5
øD'	øD + 0.5 max.				
L'	L + 2.0 max				

※ ø16 x 60L, L' ≤ L+3.0

RATINGS OF NZH Series

V _{dc}	450	
Items μF	∅D×L(mm)	Rated Ripple Current (mA _{rms} /105°C, 120Hz)
18	8 X 50	240
39	10 X 50	400
47	12.5 X 40	460
	16 X 25	460
56	12.5 X 50	550
	16 X 31.5	550
	18 X 25	550
68	12.5 X 50	690
	16 X 35.5	690
	18 X 31.5	690
82	12.5 X 60	750
	16 X 40	750
	18 X 31.5	750
100	16 X 45	800
	18 X 35.5	800
120	16 X 50	950
	18 X 40	950
150	16 X 60	1,300
	18 X 50	1,300

RATED RIPPLE CURRENT MULTIPLIERS

Frequency Multipliers

Freq.(Hz) Cap.(μF)	120	1k	10k	50k	100k
18 ~ 150	1.00	1.25	1.50	1.75	2.00

NZR Series

- 105°C 2,000Hrs assured.

- Non-solvent proof
- High ripple and High surge voltage
- For LED TV Power , SMPS
- **RoHS compliant.**
- **Halogen-free capacitors are also available.**

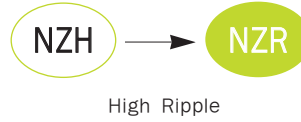

SPECIFICATIONS

Item	Characteristics											
Rated Voltage	450 V _{dc}											
Surge Voltage	550 V _{dc}											
Operating Temperature Range	-25 ~ +105°C											
Capacitance Tolerance	±20%(M) (at 20°C, 120Hz)											
Leakage Current	<table border="1"> <thead> <tr> <th>CV</th> <th>Time</th> <th>After 1 minute</th> <th>After 5 minutes</th> </tr> </thead> <tbody> <tr> <td rowspan="2">≤ 1000</td> <td></td> <td>I=0.1CV+40</td> <td>I=0.03CV+15</td> </tr> <tr> <td></td> <td>I=0.04CV+100</td> <td>I=0.02CV+25</td> </tr> </tbody> </table> <p>Where, I : Max. Leakage current(μA) C : Nominal capacitance(μF) V : Rated voltage(V_{dc}) (at 20°C)</p>	CV	Time	After 1 minute	After 5 minutes	≤ 1000		I=0.1CV+40	I=0.03CV+15		I=0.04CV+100	I=0.02CV+25
CV	Time	After 1 minute	After 5 minutes									
≤ 1000		I=0.1CV+40	I=0.03CV+15									
		I=0.04CV+100	I=0.02CV+25									
Dissipation Factor(Tanδ)	<table border="1"> <tbody> <tr> <td>Rated Voltage(V_{dc})</td> <td>450</td> </tr> <tr> <td>Tanδ(Max.)</td> <td>0.24</td> </tr> </tbody> </table> <p>(at 20°C, 120Hz)</p>	Rated Voltage(V _{dc})	450	Tanδ(Max.)	0.24							
Rated Voltage(V _{dc})	450											
Tanδ(Max.)	0.24											
Temperature Characteristics (Max. Impedance ratio)	<table border="1"> <tbody> <tr> <td>Rated Voltage(V_{dc})</td> <td>450</td> </tr> <tr> <td>Z(-25°C)/Z(20°C)</td> <td>6</td> </tr> </tbody> </table> <p>(at 120Hz)</p>	Rated Voltage(V _{dc})	450	Z(-25°C)/Z(20°C)	6							
Rated Voltage(V _{dc})	450											
Z(-25°C)/Z(20°C)	6											
Load Life	<p>The following specifications shall be satisfied when the capacitors are restored to 20°C after the rated voltage with the rated ripple current is applied for 2,000 hours at 105°C.</p> <p>Capacitance change ≤ ±20 % of the initial value tan δ ≤ 200 % of the initial specified value Leakage current ≤ The initial specified value</p>											
Shelf Life	<p>The following specifications shall be satisfied when the capacitors are restored to 20°C after exposing them for 1,000 hours at 105°C without voltage applied. The rated voltage shall be applied to the capacitors for a minimum of 30 minutes, at least 24 hours and not more than 48 hours before the measurements.</p> <p>Capacitance change ≤ ±20 % of the initial value tan δ ≤ 200 % of the initial specified value Leakage current ≤ 500 % of the initial specified value</p>											
Others	Satisfied characteristics KS C IEC 60384-4											

DIMENSIONS OF NZR Series

Unit(mm)

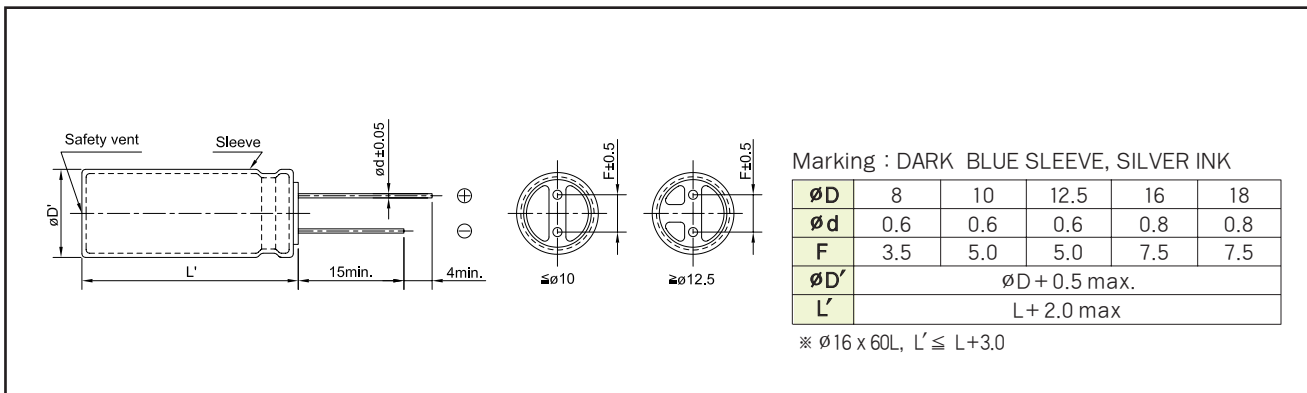

RATINGS OF NZR Series

V _{dc}		450	
Items μF	∅D×L(mm)	Rated Ripple Current (mA _{rms} /105°C, 120Hz)	
23	8 X 50	300	
39	10 X 50	450	
51		480	
62	10 X 60	570	
68	12.5 X 50	750	
	16 X 35.5	750	
	18 X 31.5	750	
82	12.5 X 60	800	
	16 X 40	800	
	18 X 31.5	800	
100	16 X 45	900	
	18 X 35.5	900	
120	16 X 50	1,000	
	18 X 40	1,000	
150	16 X 60	1,400	
	18 X 50	1,400	

RATED RIPPLE CURRENT MULTIPLIERS

Frequency Multipliers

Cap.(μF) \ Freq.(Hz)	120	1k	10k	50k	100k
23 ~ 150	1.00	1.25	1.50	1.75	2.00

NLF Series

- 105°C 5,000Hrs assured.

- Non-solvent proof
- This series adopts the electrolyte which was excellent in fire retardancy compared with the conventional series
- For LED TV Power, SMPS, IP-Board
- RoHS compliant.
- Halogen-free capacitors are also available



SPECIFICATIONS

Item	Characteristics						
Rated Voltage	400~500 V _{DC}						
Operating Temperature Range	-25 ~ +105°C						
Capacitance Tolerance	±20% (M) (at 20°C, 120Hz)						
Leakage Current	<table border="1"> <tr> <td>After 1 minute</td> <td>After 5 minutes</td> </tr> <tr> <td>CV ≤ 1,000</td> <td>CV > 1,000</td> </tr> <tr> <td>I = 0.03CV + 40</td> <td>I = 0.06CV + 100</td> </tr> </table> <p>Where, I : Max. Leakage current(μA) C : Nominal capacitance(μF) V : Rated voltage(V_{DC}) (at 20°C)</p>	After 1 minute	After 5 minutes	CV ≤ 1,000	CV > 1,000	I = 0.03CV + 40	I = 0.06CV + 100
After 1 minute	After 5 minutes						
CV ≤ 1,000	CV > 1,000						
I = 0.03CV + 40	I = 0.06CV + 100						
Dissipation Factor(Tanδ)	<table border="1"> <tr> <td>Rated Voltage(V_{DC})</td> <td>400~500</td> </tr> <tr> <td>Tanδ(Max.)</td> <td>0.24</td> </tr> </table> <p>(at 20°C, 120Hz)</p>	Rated Voltage(V _{DC})	400~500	Tanδ(Max.)	0.24		
Rated Voltage(V _{DC})	400~500						
Tanδ(Max.)	0.24						
Temperature Characteristics (Max. Impedance ratio)	<table border="1"> <tr> <td>Rated Voltage(V_{DC})</td> <td>400~500</td> </tr> <tr> <td>Z(-25°C)/Z(20°C)</td> <td>6</td> </tr> </table> <p>(at 120Hz)</p>	Rated Voltage(V _{DC})	400~500	Z(-25°C)/Z(20°C)	6		
Rated Voltage(V _{DC})	400~500						
Z(-25°C)/Z(20°C)	6						
Load Life	<p>The following specifications shall be satisfied when the capacitors are restored to 20°C after the rated voltage with the rated ripple current is applied for 5,000 hours at 105°C.</p> <p>Capacitance change ≤ ±20 % of the initial value tan δ ≤ 200 % of the initial specified value Leakage current ≤ The initial specified value</p>						
Shelf Life	<p>The following specifications shall be satisfied when the capacitors are restored to 20°C after exposing them for 1,000 hours at 105°C without voltage applied. The rated voltage shall be applied to the capacitors for a minimum of 30 minutes, at least 24 hours and not more than 48 hours before the measurements.</p> <p>Capacitance change ≤ ±20 % of the initial value tan δ ≤ 200 % of the initial specified value Leakage current ≤ 500 % of the initial specified value</p>						
Others	Satisfied characteristics KS C IEC 60384-4						

■ The specifications and the size depend on the safety requirement.(flame retardant)
Please consult us for any further details.

DIMENSIONS OF NLF Series

Unit(mm)

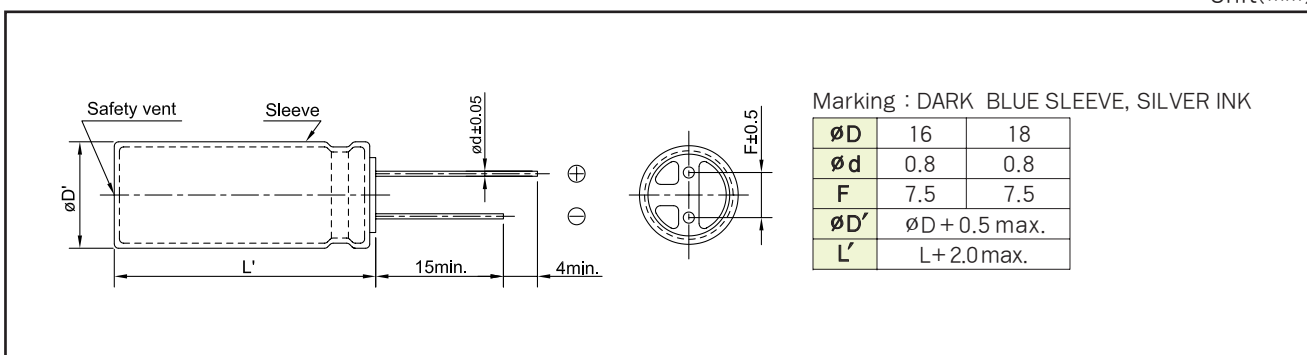

RDC Series

• 85°C 2,000Hrs assured.

- Non-solvent proof.
- For SMPS, Inverter.
- RoHS compliant.
- Halogen-free capacitors are also available.



SPECIFICATIONS

Item	Characteristics																												
Rated Voltage Range	16 ~ 100 V _{DC}	160 ~ 500 V _{DC}																											
Operating Temperature Range	-40 ~ +85°C	-25 ~ +85°C																											
Capacitance Tolerance	±20% (M) (at 20°C, at 120Hz)																												
Leakage Current	I = 0.02CV(µA) or 3mA, whichever is smaller. Where, I:Max. Leakage current(µA) C:Nominal capacitance(µF) V:Rated voltage(V _{DC}) (at 20°C, 5 minutes)																												
※ Dissipation Factor(Tanδ)	<table border="1"> <thead> <tr> <th>Rated Voltage(V_{DC})</th> <th>16</th> <th>25</th> <th>35</th> <th>50~63</th> <th>100</th> <th>160~250</th> <th>315~400</th> <th>450~500</th> </tr> </thead> <tbody> <tr> <td>Tanδ(Max.)</td> <td>0.40</td> <td>0.35</td> <td>0.30</td> <td>0.25</td> <td>0.20</td> <td>0.15</td> <td>0.15</td> <td>0.20</td> </tr> </tbody> </table> <p>(at 20°C, 120Hz)</p>		Rated Voltage(V _{DC})	16	25	35	50~63	100	160~250	315~400	450~500	Tanδ(Max.)	0.40	0.35	0.30	0.25	0.20	0.15	0.15	0.20									
Rated Voltage(V _{DC})	16	25	35	50~63	100	160~250	315~400	450~500																					
Tanδ(Max.)	0.40	0.35	0.30	0.25	0.20	0.15	0.15	0.20																					
Temperature Characteristics (Max.Impedance ratio)	<table border="1"> <thead> <tr> <th>Rated Voltage(V_{DC})</th> <th>16</th> <th>25</th> <th>35</th> <th>50~63</th> <th>100</th> <th>160~250</th> <th>315~400</th> <th>450~500</th> </tr> </thead> <tbody> <tr> <td>Z(-25°C)/Z(20°C)</td> <td>4</td> <td>3</td> <td>3</td> <td>2</td> <td>2</td> <td>4</td> <td>4</td> <td>8</td> </tr> <tr> <td>Z(-40°C)/Z(20°C)</td> <td>15</td> <td>10</td> <td>8</td> <td>6</td> <td>5</td> <td>-</td> <td>-</td> <td>-</td> </tr> </tbody> </table> <p>(at 120Hz)</p>		Rated Voltage(V _{DC})	16	25	35	50~63	100	160~250	315~400	450~500	Z(-25°C)/Z(20°C)	4	3	3	2	2	4	4	8	Z(-40°C)/Z(20°C)	15	10	8	6	5	-	-	-
Rated Voltage(V _{DC})	16	25	35	50~63	100	160~250	315~400	450~500																					
Z(-25°C)/Z(20°C)	4	3	3	2	2	4	4	8																					
Z(-40°C)/Z(20°C)	15	10	8	6	5	-	-	-																					
Load Life	<p>The following specifications shall be satisfied when the capacitors are restored to 20°C after the rated voltage is applied for 2,000 hours at 85°C.</p> <p>Capacitance change ≤ ±20% of the initial value Tanδ ≤ 200% of the initial specified value Leakage Current ≤ The initial specified value</p>																												
Shelf Life	<p>The following specifications shall be satisfied when the capacitors are restored to 20°C after exposing them at 85°C for 1,000 hours without voltage applied. The rated voltage shall be applied to the capacitors for a minimum of 30 minutes, at least 25 hours and not more than 48 hours before the measurements.</p> <p>Capacitance change ≤ ±20% of the initial value Tanδ ≤ 200% of the initial specified value Leakage Current ≤ The initial specified value</p>																												
Others	Satisfied characteristics KS C IEC 60384-4																												

※ For capacitors with CV products > 100,000 Higher Tanδ value may apply.
 When the capacitance exceed 1,000µF, 0.01 shall be added every 1,000µF increase.

RATED RIPPLE CURRENT

When capacitors are operated in any other condition at 120Hz, the maximum ripple current must be multiplied by the figure shown in the table.

Frequency multiplying factor

V _{DC}	Freq.(Hz)	60	120	300	1k	10k~
16~50V _{DC}		0.95	1.00	1.03	1.05	1.08
63~100V _{DC}		0.92	1.00	1.07	1.13	1.19
160~250V _{DC}		0.81	1.00	1.17	1.32	1.45
315~500V _{DC}		0.77	1.00	1.16	1.30	1.41

DIMENSIONS OF RDC Series

Unit(mm)

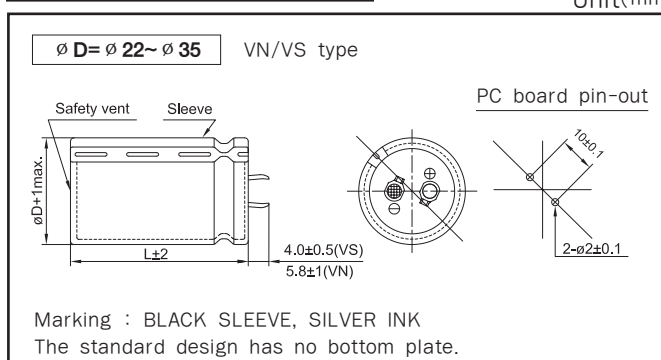



LARGE SIZED ALUMINUM ELECTROLYTIC CAPACITORS

RATINGS OF RDC Series

V _{DC} μF ∅ D	16				25				35			
	22	25.4	30	35	22	25.4	30	35	22	25.4	30	35
3,900									22 × 25 2.22			
4,700									22 × 30 2.41	25.4 × 25 2.42		
5,600					22 × 25 2.21				22 × 35 2.75	25.4 × 25 2.64		
6,800					22 × 30 2.40	25.4 × 25 2.56			22 × 40 2.80	25.4 × 30 2.74	30 × 25 2.97	
8,200	22 × 25 2.51				22 × 35 2.72	25.4 × 25 2.80			22 × 45 3.11	25.4 × 35 3.10	30 × 30 3.13	
10,000	22 × 25 2.77				22 × 40 3.09	25.4 × 30 3.12	30 × 25 3.21			25.4 × 40 3.53	30 × 30 3.46	35 × 25 3.20
12,000	22 × 30 2.86	25.4 × 25 2.95			22 × 45 3.48	25.4 × 35 3.43	30 × 30 3.86	35 × 25 3.54		25.4 × 45 3.98	30 × 35 4.01	35 × 30 4.02
15,000	22 × 35 3.29	25.4 × 30 3.46	30 × 25 3.66		22 × 50 4.00	25.4 × 40 3.95	30 × 30 4.00	35 × 25 3.95			30 × 40 4.90	35 × 35 5.01
18,000	22 × 40 3.72	25.4 × 35 3.98	30 × 30 3.98			25.4 × 45 4.45	30 × 35 4.46	35 × 30 4.63			30 × 45 5.43	35 × 40 5.54
22,000	22 × 50 4.37	25.4 × 40 4.26	30 × 30 4.21			25.4 × 50 5.02	30 × 45 5.21	35 × 35 5.16				35 × 45 6.04
27,000		25.4 × 45 4.72	30 × 35 4.82				30 × 50 5.94	35 × 40 5.92				35 × 50 6.89
33,000			30 × 40 5.36	35 × 30 5.15				35 × 45 6.75				
39,000			30 × 45 6.01	35 × 35 5.95				35 × 50 7.56				
47,000			30 × 50 6.79	35 × 40 6.76								
56,000				35 × 45 7.62								

V _{DC} μF ∅ D	50				63				100			
	22	25.4	30	35	22	25.4	30	35	22	25.4	30	35
820									22 × 25 1.86			
1,000									22 × 30 1.93			
1,200									22 × 30 2.09	25.4 × 25 2.10		
1,500									22 × 35 2.41	25.4 × 30 2.34	30 × 25 2.46	
1,800					22 × 25 1.82				22 × 40 2.71	25.4 × 35 2.75	30 × 25 2.72	
2,200	22 × 25 1.91				22 × 30 2.31	25.4 × 25 2.30			22 × 45 3.08	25.4 × 40 3.13	30 × 30 3.09	35 × 25 3.14
2,700	22 × 30 2.11	25.4 × 25 2.13			22 × 35 2.43	25.4 × 30 2.43				25.4 × 45 3.57	30 × 35 3.55	35 × 30 3.71
3,300	22 × 30 2.37	25.4 × 25 2.38			22 × 35 2.62	25.4 × 30 2.64	30 × 25 2.78			25.4 × 50 4.06	30 × 40 4.05	35 × 30 4.05
3,900	22 × 35 2.65	25.4 × 30 2.68			22 × 40 2.93	25.4 × 35 2.97	30 × 30 3.00				30 × 45 4.54	35 × 35 4.49
4,700	22 × 40 2.99	25.4 × 35 3.03	30 × 25 2.81		22 × 50 3.39	25.4 × 40 3.36	30 × 30 3.32	35 × 25 3.36			30 × 50 5.11	35 × 40 5.11
5,600	22 × 45 3.36	25.4 × 35 3.31	30 × 30 3.37	35 × 25 3.42		25.4 × 45 3.77	30 × 35 3.75	35 × 25 3.76				35 × 45 5.75
6,800	22 × 50 3.81	25.4 × 40 3.81	30 × 35 3.85	35 × 30 3.85		25.4 × 50 4.27	30 × 40 4.27	35 × 30 4.15				
8,200		25.4 × 50 4.37	30 × 40 4.36	35 × 30 4.41			30 × 45 4.83	35 × 35 4.79				
10,000			30 × 45 4.97	35 × 35 4.92			30 × 50 5.49	35 × 40 5.47				
12,000			30 × 50 5.60	35 × 40 5.58				35 × 45 6.19				
15,000				35 × 45 6.44								
18,000				35 × 50 6.71								

← Case Size ∅ D × L (mm)
 ← Rated Ripple Current (Arms/85°C, 120Hz)

RATINGS OF RDC Series

μF	V_{DC} ϕD	160				200				250			
		22	25.4	30	35	22	25.4	30	35	22	25.4	30	35
330										22 × 30 1.49	25.4 × 25 1.51	30 × 20 1.48	
390										22 × 35 1.67	25.4 × 30 1.63	30 × 25 1.66	
470					22 × 30 1.78	25.4 × 25 1.80				22 × 40 1.88	25.4 × 30 1.86	30 × 25 1.89	35 × 20 1.89
560	22 × 30 1.95				22 × 35 2.00	25.4 × 30 1.97	30 × 25 2.01			22 × 45 2.13	25.4 × 35 2.09	30 × 30 2.14	35 × 25 2.09
680	22 × 30 2.15				22 × 40 2.27	25.4 × 30 2.24	30 × 25 2.28				25.4 × 50 2.44	30 × 35 2.43	35 × 25 2.46
820	22 × 35 2.42	25.4 × 30 2.45			22 × 45 2.58	25.4 × 35 2.53	30 × 30 2.59					30 × 40 2.75	35 × 30 2.77
1,000	22 × 40 2.75	25.4 × 35 2.79				25.4 × 40 2.88	30 × 35 2.95	35 × 25 2.90				30 × 45 3.31	35 × 35 3.22
1,200		25.4 × 40 3.15	30 × 30 3.13	35 × 25 3.27			30 × 40 3.34	35 × 30 3.31					35 × 40 3.42
1,500		25.4 × 45 3.60	30 × 35 3.63	35 × 30 3.57			30 × 45 3.84	35 × 35 3.82					35 × 45 4.06
1,800			30 × 40 4.09	35 × 30 4.05				35 × 40 4.33					
2,200				35 × 35 4.63				35 × 45 4.92					
2,700				35 × 40 5.30									

μF	V_{DC} ϕD	315				350				400			
		22	25.4	30	35	22	25.4	30	35	22	25.4	30	35
150	22 × 25 0.98									22 × 30 1.02			
180	22 × 30 1.10					22 × 30 1.11				22 × 35 1.14			
220	22 × 35 1.26	25.4 × 25 1.23	30 × 20 1.25		22 × 35 1.26					22 × 40 1.29	25.4 × 30 1.27	30 × 25 1.30	
270	22 × 40 1.43	25.4 × 30 1.41	30 × 25 1.43	35 × 20 1.45	22 × 40 1.49	25.4 × 30 1.46	30 × 25 1.49			22 × 45 1.48	25.4 × 35 1.45	30 × 30 1.48	
330	22 × 45 1.62	25.4 × 35 1.61	30 × 25 1.62	35 × 20 1.61	22 × 45 1.66	25.4 × 35 1.63	30 × 30 1.67				25.4 × 40 1.65	30 × 30 1.65	35 × 25 1.67
390		25.4 × 40 1.79	30 × 30 1.78	35 × 25 1.86		25.4 × 40 1.88	30 × 30 1.88	35 × 25 1.94			25.4 × 45 1.84	30 × 35 1.85	35 × 30 1.88
470			30 × 35 2.02	35 × 30 2.07		25.4 × 45 2.18	30 × 35 2.20	35 × 30 2.25				30 × 40 2.09	35 × 30 2.07
560			30 × 40 2.28	35 × 35 2.33			30 × 45 2.40	35 × 30 2.37					35 × 35 2.34
680				35 × 40 2.66				35 × 35 2.78					35 × 45 2.74
820				35 × 45 3.00				35 × 40 3.15					

← Case Size $\phi D \times L$ (mm)
 ← Rated Ripple Current(Arms/85°C, 120Hz)



LARGE SIZED ALUMINUM ELECTROLYTIC CAPACITORS

RATINGS OF RDC Series

μF	V _{DC} ϕ D	450				500			
		22	25.4	30	35	22	25.4	30	35
68						22 × 30 0.40			
82						22 × 30 0.51	25.4 × 25 0.53		
100							25.4 × 35 0.69		
120		22 × 30 0.91	25.4 × 25 0.91				25.4 × 40 0.86		
150		22 × 35 1.04	25.4 × 30 1.05				25.4 × 45 0.91	30 × 30 0.88	
180		22 × 40 1.18	25.4 × 30 1.15	30 × 25 1.17			25.4 × 50 0.96	30 × 35 0.99	
220		22 × 45 1.33	25.4 × 35 1.31	30 × 30 1.36				30 × 40 1.15	
270			25.4 × 40 1.55	30 × 35 1.60	35 × 25 1.59			30 × 50 1.44	35 × 35 1.36
330				30 × 40 1.90	35 × 30 1.88				35 × 40 1.49
390				30 × 45 2.09	35 × 35 2.08				35 × 45 1.71
470					35 × 40 2.40				35 × 50 2.08
560					35 × 45 2.70	← Case Size ϕ D × L (mm) ← Rated Ripple Current (Arms/85°C, 120Hz)			

TDA Series

• 105°C 2,000Hrs assured.

- Non-solvent proof.
- For SMPS, Inverter.
- RoHS compliant.
- Halogen-free capacitors are also available.



SPECIFICATIONS

Item	Characteristics																									
Rated Voltage Range	16 ~ 100 V _{DC}	160 ~ 500 V _{DC}																								
Operating Temperature Range	-40 ~ +105°C	-25 ~ +105°C																								
Capacitance Tolerance	±20% (M) (at 20°C, at 120Hz)																									
Leakage Current	I = 0.02CV(µA) or 3mA, whichever is smaller. Where, I: Max. Leakage current(µA) C: Nominal capacitance(µF) V: Rated voltage(V _{DC}) (at 20°C, 5 minutes)																									
※ Dissipation Factor(Tanδ)	<table border="1"> <tr> <td>Rated Voltage(V_{DC})</td> <td>16</td> <td>25~35</td> <td>50~63</td> <td>100</td> <td>160~400</td> <td>420~500</td> </tr> <tr> <td>Tanδ(Max.)</td> <td>0.40</td> <td>0.35</td> <td>0.25</td> <td>0.20</td> <td>0.15</td> <td>0.20</td> </tr> </table> (at 20°C, 120Hz)		Rated Voltage(V _{DC})	16	25~35	50~63	100	160~400	420~500	Tanδ(Max.)	0.40	0.35	0.25	0.20	0.15	0.20										
Rated Voltage(V _{DC})	16	25~35	50~63	100	160~400	420~500																				
Tanδ(Max.)	0.40	0.35	0.25	0.20	0.15	0.20																				
Temperature Characteristics (Max. Impedance ratio)	<table border="1"> <tr> <td>Rated Voltage(V_{DC})</td> <td>16</td> <td>25</td> <td>35</td> <td>50~63</td> <td>100</td> <td>160~400</td> <td>420~500</td> </tr> <tr> <td>Z(-25°C)/Z(20°C)</td> <td>4</td> <td>3</td> <td>3</td> <td>2</td> <td>2</td> <td>4</td> <td>8</td> </tr> <tr> <td>Z(-40°C)/Z(20°C)</td> <td>15</td> <td>10</td> <td>8</td> <td>6</td> <td>5</td> <td>-</td> <td>-</td> </tr> </table> (at 120Hz)		Rated Voltage(V _{DC})	16	25	35	50~63	100	160~400	420~500	Z(-25°C)/Z(20°C)	4	3	3	2	2	4	8	Z(-40°C)/Z(20°C)	15	10	8	6	5	-	-
Rated Voltage(V _{DC})	16	25	35	50~63	100	160~400	420~500																			
Z(-25°C)/Z(20°C)	4	3	3	2	2	4	8																			
Z(-40°C)/Z(20°C)	15	10	8	6	5	-	-																			
Load Life	The following specifications shall be satisfied when the capacitors are restored to 20°C after the rated voltage is applied for 2,000 hours at 105°C. Capacitance change ≤ ±20% of the initial value Tanδ ≤ 200% of the initial specified value Leakage Current ≤ The initial specified value																									
Shelf Life	The following specifications shall be satisfied when the capacitors are restored to 20°C after the exposing them at 105°C for 1,000 hours without voltage applied. The rated voltage shall be applied to the capacitors for a minimum of 30 minutes, at least 24 hours and not more than 48 hours before the measurements. Capacitance change ≤ ±20% of the initial value Tanδ ≤ 200% of the initial specified value Leakage Current ≤ The initial specified value																									
Others	Satisfied characteristics KS C IEC 60384-4																									

※ For capacitors with CV products > 100,000 Higher Tanδ value may apply.
When the capacitors exceed 1,000µF, 0.01 shall be added every 1,000µF increase.

RATED RIPPLE CURRENT

When capacitors are operated in any other condition at 120Hz, the maximum ripple current must be multiplied by the figure shown in the table.

Frequency multiplying factor

V _{DC}	Freq.(Hz)	60	120	300	1k	10k~
16~50V _{DC}		0.95	1.00	1.03	1.05	1.08
63~100V _{DC}		0.92	1.00	1.07	1.13	1.19
160~250V _{DC}		0.81	1.00	1.17	1.32	1.45
315~500V _{DC}		0.77	1.00	1.16	1.30	1.41

DIMENSIONS OF TDA Series

Unit(mm)

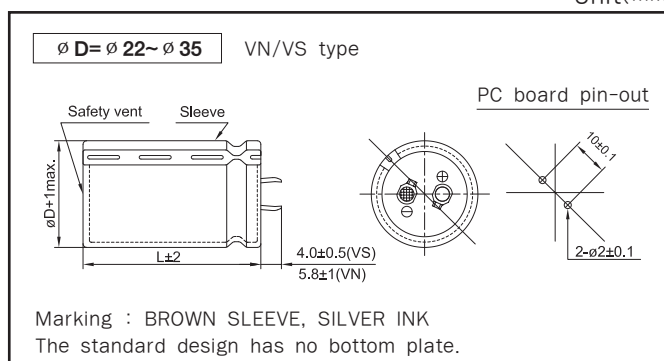



LARGE SIZED ALUMINUM ELECTROLYTIC CAPACITORS

RATINGS OF TDA Series

μF	V_{DC} ϕD	16				25				35			
		22	25.4	30	35	22	25.4	30	35	22	25.4	30	35
3,300										22 × 25 1.40			
3,900										22 × 30 1.57			
4,700						22 × 25 1.50				22 × 30 1.72	25.4 × 25 1.80		
5,600						22 × 25 1.63				22 × 35 1.95	25.4 × 30 1.96	30 × 25 1.99	
6,800	22 × 25 1.57					22 × 30 1.86	25.4 × 25 1.87			22 × 40 2.20	25.4 × 35 2.23	30 × 25 2.19	
8,200	22 × 30 1.73					22 × 35 2.11	25.4 × 30 2.12	30 × 25 2.15		22 × 50 2.55	25.4 × 40 2.53	30 × 30 2.53	
10,000	22 × 30 1.97	25.4 × 25 1.97				22 × 40 2.39	25.4 × 35 2.42	30 × 25 2.39			25.4 × 45 2.87	30 × 35 2.90	35 × 30 2.75
12,000	22 × 35 2.22	25.4 × 30 2.24				22 × 45 2.69	25.4 × 40 2.74	30 × 30 2.70	35 × 25 2.74		25.4 × 50 3.24	30 × 40 3.23	35 × 30 3.23
15,000	22 × 40 2.55	25.4 × 35 2.58					25.4 × 45 3.15	30 × 35 3.13	35 × 30 3.27			30 × 45 3.72	35 × 35 3.67
18,000	22 × 45 2.87	25.4 × 40 2.92	30 × 30 2.88				25.4 × 50 3.54	30 × 40 3.54	35 × 30 3.50				35 × 40 4.37
22,000		25.4 × 45 3.32	30 × 35 3.29					30 × 45 4.04	35 × 35 3.97				35 × 50 4.92
27,000		25.4 × 50 3.78	30 × 40 3.77	35 × 30 3.45					35 × 45 4.73				
33,000			30 × 45 4.30	35 × 35 4.26					35 × 50 5.39				
39,000			30 × 50 4.81	35 × 40 4.79									
47,000				35 × 50 5.43									

μF	V_{DC} ϕD	50				63				100			
		22	25.4	30	35	22	25.4	30	35	22	25.4	30	35
560										22 × 25 1.06			
820										22 × 30 1.32	25.4 × 25 1.33		
1,000										22 × 35 1.50	25.4 × 30 1.51		
1,200						22 × 25 1.19				22 × 40 1.69	25.4 × 35 1.71	30 × 25 1.68	
1,500						22 × 25 1.33				22 × 45 1.94	25.4 × 40 1.98	30 × 30 1.95	
1,800	22 × 25 1.33					22 × 30 1.51	25.4 × 25 1.52				25.4 × 45 2.23	30 × 35 2.26	35 × 25 2.17
2,200	22 × 30 1.50					22 × 35 1.73	25.4 × 30 1.74				25.4 × 50 2.53	30 × 40 2.57	35 × 30 2.50
2,700	22 × 30 1.69	25.4 × 25 1.70				22 × 40 1.97	25.4 × 35 1.99	30 × 25 1.91				30 × 45 2.88	35 × 35 2.86
3,300	22 × 35 1.93	25.4 × 30 1.85				22 × 50 2.29	25.4 × 40 2.27	30 × 30 2.24				30 × 50 3.28	35 × 40 3.27
3,900	22 × 40 2.16	25.4 × 35 2.18	30 × 25 2.15				25.4 × 45 2.54	30 × 35 2.56	35 × 25 2.56				35 × 45 3.67
4,700	22 × 45 2.43	25.4 × 35 2.39	30 × 30 2.35	35 × 25 2.48			25.4 × 50 2.86	30 × 40 2.86	35 × 30 2.79				35 × 50 3.80
5,600	22 × 50 2.75	25.4 × 40 2.70	30 × 35 2.76	35 × 25 2.70				30 × 45 3.22	35 × 35 3.19				
6,800		25.4 × 50 3.30	30 × 40 3.30	35 × 30 3.25				30 × 50 3.66	35 × 40 3.64				
8,200			30 × 45 3.60	35 × 35 3.56					35 × 45 3.90				
10,000			30 × 50 4.04	35 × 40 4.03					35 × 50 4.40				
12,000				35 × 45 4.56									

← Case Size $\phi D \times L$ (mm)
 ← Rated Ripple Current(Arms/105°C, 120Hz)

RATINGS OF TDA Series

μF \ V _{DC} / ∅ D	160				200				250			
	22	25.4	30	35	22	25.4	30	35	22	25.4	30	35
100												
120										25.4 × 20 0.48		
150					22 × 20 0.53					25.4 × 20 0.59		
180					22 × 20 0.62	25.4 × 20 0.64			22 × 25 0.78	25.4 × 20 0.75		
220		25.4 × 20 0.66			22 × 25 0.70	25.4 × 20 0.70			22 × 30 0.96	25.4 × 25 0.95	30 × 20 0.93	
270		25.4 × 20 0.80			22 × 25 0.87	25.4 × 20 0.83			22 × 30 1.11	25.4 × 25 1.10	30 × 20 1.10	
330	22 × 25 1.20	25.4 × 20 1.10			22 × 30 1.20	25.4 × 25 1.21	30 × 20 1.20		22 × 35 1.20	25.4 × 30 1.20	30 × 25 1.26	35 × 20 1.17
390	22 × 30 1.30	25.4 × 25 1.29	30 × 20 1.19		22 × 30 1.28	25.4 × 25 1.27	30 × 25 1.25		22 × 40 1.45	25.4 × 35 1.49	30 × 25 1.44	35 × 25 1.49
470	22 × 30 1.36	25.4 × 25 1.39	30 × 20 1.31	35 × 20 1.35	22 × 35 1.41	25.4 × 30 1.41	30 × 25 1.50	35 × 20 1.30	22 × 45 1.53	25.4 × 35 1.50	30 × 30 1.57	35 × 25 1.57
560	22 × 35 1.46	25.4 × 30 1.51	30 × 25 1.54	35 × 20 1.41	22 × 45 1.56	25.4 × 35 1.53	30 × 30 1.57	35 × 25 1.52	22 × 50 1.77	25.4 × 40 1.74	30 × 30 1.73	35 × 25 1.72
680	22 × 40 1.66	25.4 × 30 1.65	30 × 25 1.68	35 × 20 1.69	22 × 45 1.73	25.4 × 35 1.69	30 × 30 1.74	35 × 25 1.72		25.4 × 50 1.84	30 × 35 1.94	35 × 30 1.97
820	22 × 45 1.99	25.4 × 30 1.95	30 × 30 2.00	35 × 25 1.91		25.4 × 45 1.99	30 × 35 2.00	35 × 30 2.04		25.4 × 60 2.20	30 × 40 2.10	35 × 35 1.98
1,000	22 × 50 2.18	25.4 × 40 2.14	30 × 30 2.15	35 × 25 2.17		25.4 × 50 2.21	30 × 40 2.23	35 × 35 2.30			30 × 50 2.31	35 × 40 2.30
1,200		25.4 × 45 2.39	30 × 35 2.37	35 × 30 2.41		25.4 × 60 2.57	30 × 45 2.53	35 × 35 2.57			30 × 60 2.50	35 × 45 2.43
1,500		25.4 × 60 2.87	30 × 40 2.74	35 × 35 2.79			30 × 50 3.01	35 × 40 2.99				35 × 50 2.80
1,800			30 × 45 3.14	35 × 35 3.11			30 × 60 3.47	35 × 45 3.38				
2,200			30 × 60 3.76	35 × 45 3.66				35 × 60 3.60				

μF \ V _{DC} / ∅ D	315				350				400			
	22	25.4	30	35	22	25.4	30	35	22	25.4	30	35
47									22 × 20 0.22			
68									22 × 25 0.51	25.4 × 20 0.46		
82	22 × 25 0.64				22 × 25 0.56				22 × 25 0.55	25.4 × 20 0.53		
100	22 × 30 0.68				22 × 25 0.67				22 × 30 0.67	25.4 × 25 0.67	30 × 20 0.60	
120	22 × 30 0.75	25.4 × 25 0.76			22 × 30 0.73	25.4 × 25 0.73			22 × 35 0.76	25.4 × 30 0.76	30 × 25 0.76	35 × 20 0.70
150	22 × 35 0.82	25.4 × 30 0.83			22 × 35 0.83	25.4 × 30 0.83	30 × 25 0.83		22 × 40 0.82	25.4 × 30 0.80	30 × 25 0.82	35 × 20 0.80
180	22 × 40 0.91	25.4 × 30 0.88	30 × 25 0.85		22 × 40 0.89	25.4 × 30 0.89	30 × 25 0.91		22 × 45 0.88	25.4 × 35 0.88	30 × 30 0.89	35 × 25 0.90
220	22 × 45 0.94	25.4 × 35 0.96	30 × 30 1.00		22 × 45 0.98	25.4 × 35 0.98	30 × 30 0.98	35 × 25 0.96	22 × 50 1.01	25.4 × 40 0.99	30 × 30 0.98	35 × 25 1.02
270		25.4 × 45 1.13	30 × 35 1.12	35 × 25 1.06	22 × 50 1.12	25.4 × 40 1.10	30 × 30 1.08	35 × 25 1.12		25.4 × 45 1.12	30 × 35 1.12	35 × 30 1.16
330		25.4 × 50 1.28	30 × 40 1.28	35 × 30 1.30		25.4 × 45 1.24	30 × 40 1.24	35 × 30 1.29		25.4 × 50 1.27	30 × 40 1.28	35 × 35 1.35
390			30 × 45 1.44	35 × 35 1.42		25.4 × 60 1.47	30 × 40 1.40	35 × 35 1.47		25.4 × 60 1.51	30 × 45 1.49	35 × 35 1.47
470			30 × 50 1.63	35 × 40 1.64		25.4 × 60 1.70	30 × 45 1.67	35 × 35 1.65			30 × 50 1.63	35 × 40 1.62
560				35 × 45 1.87			30 × 50 1.87	35 × 40 1.86			30 × 60 1.88	35 × 50 1.88
680				35 × 50 2.07			30 × 60 2.18	35 × 50 2.18				35 × 60 2.19
820								35 × 60 2.53	← Case Size ∅ D × L (mm) ← Rated Ripple Current (Arms/105°C, 120Hz)			

RATINGS OF TDA Series

μF	V _{DC} ϕ D	420				450				500			
		22	25.4	30	35	22	25.4	30	35	22	25.4	30	35
56						22 × 25 0.40				22 × 35 0.46	25.4 × 30 0.46	30 × 30 0.48	
68		22 × 25 0.50				22 × 30 0.50	25.4 × 25 0.50			22 × 40 0.53	25.4 × 35 0.53	30 × 30 0.55	
82		22 × 25 0.51	25.4 × 25 0.63			22 × 30 0.55	25.4 × 25 0.54			22 × 45 0.56	25.4 × 35 0.58	30 × 35 0.58	
100		22 × 30 0.58	25.4 × 30 0.69			22 × 35 0.62	25.4 × 30 0.62	30 × 25 0.64			25.4 × 40 0.65	30 × 35 0.66	
120		22 × 35 0.72	25.4 × 30 0.73	30 × 25 0.75		22 × 40 0.70	25.4 × 35 0.71	30 × 30 0.72	35 × 25 0.73		25.4 × 45 0.75	30 × 40 0.76	35 × 30 0.78
150		22 × 45 0.79	25.4 × 35 0.74	30 × 25 0.75	35 × 25 0.81	22 × 45 0.77	25.4 × 40 0.75	30 × 30 0.74	35 × 25 0.75			30 × 45 0.80	35 × 35 0.81
180		22 × 50 0.89	25.4 × 40 0.89	30 × 30 0.88	35 × 25 0.87		25.4 × 45 0.84	30 × 35 0.87	35 × 30 0.88			30 × 50 0.90	35 × 40 0.93
220			25.4 × 45 1.01	30 × 35 1.00	35 × 30 1.05		25.4 × 50 0.98	30 × 40 0.98	35 × 30 1.00			30 × 60 1.10	35 × 45 1.11
270				30 × 45 1.19	35 × 35 1.19		25.4 × 60 1.17	30 × 45 1.15	35 × 35 1.17				35 × 50 1.28
330				30 × 50 1.36	35 × 40 1.39			30 × 50 1.38	35 × 40 1.38				35 × 60 1.50
390					35 × 45 1.57			30 × 60 1.60	35 × 45 1.56				
470					35 × 50 1.73				35 × 50 1.72				
560									35 × 60 1.98	← Case Size ϕ D × L (mm) ← Rated Ripple Current (Arms/105°C, 120Hz)			

TDC Series

• 105°C 2,000Hrs assured.

- Non-solvent proof.
- Downsized.
- For SMPS, Inverter.
- RoHS compliant.
- Halogen-free capacitors are also available.



SPECIFICATIONS

Item	Characteristics						
Rated Voltage Range	160 ~ 500 V _{dc}						
Operating Temperature Range	-25 ~ +105°C						
Capacitance Tolerance	±20% (M) (at 20°C, 120Hz)						
Leakage Current	I = 0.02CV or 3mA, whichever is smaller. Where, I: Leakage current(μA) C: Nominal capacitance(μF) V: Rated voltage(V _{dc}) (at 20°C, 5 minutes)						
※ Dissipation Factor(Tanδ)	<table border="1"> <tr> <td>Rated Voltage(V_{dc})</td> <td>160~400</td> <td>420~500</td> </tr> <tr> <td>Tanδ(Max.)</td> <td>0.15</td> <td>0.20</td> </tr> </table> <p>(at 20°C, 120Hz)</p>	Rated Voltage(V _{dc})	160~400	420~500	Tanδ(Max.)	0.15	0.20
Rated Voltage(V _{dc})	160~400	420~500					
Tanδ(Max.)	0.15	0.20					
Temperature Characteristics (Max.Impedance ratio)	<table border="1"> <tr> <td>Rated Voltage(V_{dc})</td> <td>160~400</td> <td>420~500</td> </tr> <tr> <td>Z(-25°C)/Z(20°C)</td> <td>4</td> <td>8</td> </tr> </table> <p>(at 120Hz)</p>	Rated Voltage(V _{dc})	160~400	420~500	Z(-25°C)/Z(20°C)	4	8
Rated Voltage(V _{dc})	160~400	420~500					
Z(-25°C)/Z(20°C)	4	8					
Load Life	<p>The following specifications shall be satisfied when the capacitors are restored to 20°C after the rated voltage is applied for 2,000 hours at 105°C.</p> <p>Capacitance change ≤ ±20% of the initial value Tanδ ≤ 200% of the initial specified value Leakage Current ≤ The initial specified value</p>						
Shelf Life	<p>The following specifications shall be satisfied when the capacitors are restored to 20°C after the exposing them at 105°C for 1,000 hours without voltage applied. The rated voltage shall be applied to the capacitors for a minimum of 30 minutes, at least 24 hours and not more than 48 hours before the measurements.</p> <p>Capacitance change ≤ ±20% of the initial value Tanδ ≤ 200% of the initial specified value Leakage Current ≤ The initial specified value</p>						
Others	Satisfied characteristics KS C IEC 60384-4						

※ For capacitors with CV products > 100,000 Higher Tanδ value may apply.
When the capacitance exceeds 1,000μF, 0.01 shall be added every 1,000μF increase.

RATED RIPPLE CURRENT

When capacitors are operated in any other condition at 120Hz, the maximum ripple current must be multiplied by the figure shown in the table.

Frequency multiplying factor

V _{dc}	Freq.(Hz)	60	120	300	1k	10k~
160~250V _{dc}		0.81	1.00	1.17	1.32	1.45
315~500V _{dc}		0.77	1.00	1.16	1.30	1.41

DIMENSIONS OF TDC Series

Unit(mm)

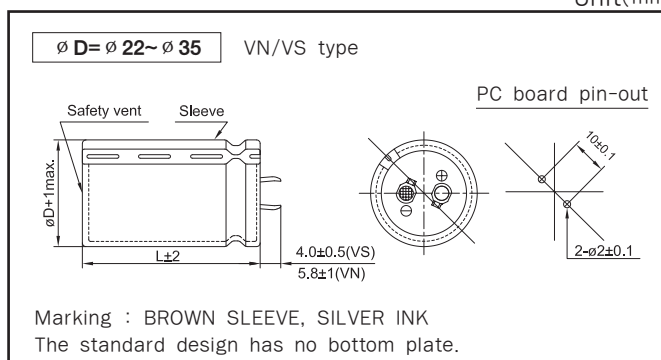

RATINGS OF TDC Series

V _{DC} μF / ∅ D	160				200				250			
	22	25.4	30	35	22	25.4	30	35	22	25.4	30	35
180									22 × 20 0.78			
220									22 × 25 1.00	25.4 × 20 0.95		
270					22 × 25 1.20					25.4 × 20 1.10		
330	22 × 20 1.20				22 × 25 1.28	25.4 × 20 1.27				25.4 × 25 1.20	30 × 20 1.26	35 × 20 1.30
390	22 × 25 1.32	25.4 × 20 1.39	30 × 20 1.31		22 × 25 1.31	25.4 × 20 1.43	30 × 20 1.43				30 × 25 1.44	35 × 20 1.49
470	22 × 30 1.46	25.4 × 25 1.51	30 × 20 1.54		22 × 30 1.45	25.4 × 25 1.53	30 × 20 1.53				30 × 25 1.57	35 × 20 1.57
560	22 × 30 1.66	25.4 × 25 1.68	30 × 25 1.68		22 × 40 1.67	25.4 × 30 1.67	30 × 25 1.67	35 × 20 1.67			30 × 30 1.80	35 × 25 1.72
680	22 × 35 1.87	25.4 × 30 1.88	30 × 25 1.96		22 × 45 1.75	25.4 × 35 1.75	30 × 25 1.74	35 × 20 1.72			30 × 30 1.94	35 × 30 2.10
820	22 × 40 2.09	25.4 × 30 2.14	30 × 25 2.15	35 × 25 2.04	22 × 50 2.04	25.4 × 40 2.04	30 × 30 2.04	35 × 25 2.04			30 × 35 2.29	35 × 30 2.36
1,000		25.4 × 35 2.38	30 × 30 2.40	35 × 25 2.55			30 × 35 2.30	35 × 30 2.30			30 × 45 2.59	35 × 35 2.63
1,200		25.4 × 40 2.66	30 × 35 2.69	35 × 30 2.86				35 × 30 2.65				

V _{DC} μF / ∅ D	315				350				400			
	22	25.4	30	35	22	25.4	30	35	22	25.4	30	35
82									22 × 20 0.55			
100	22 × 25 0.75								22 × 25 0.66	25.4 × 20 0.67		
120	22 × 25 0.82				22 × 25 0.72					25.4 × 25 0.76		
150	22 × 30 0.91	25.4 × 25 0.94			22 × 30 0.84	25.4 × 25 0.89				25.4 × 25 0.86	30 × 20 0.89	
180		25.4 × 25 1.13			22 × 35 0.98	25.4 × 30 0.94				25.4 × 30 0.97	30 × 25 1.02	35 × 20 1.02
220		25.4 × 30 1.19	30 × 25 1.17		22 × 40 1.04	25.4 × 30 1.07	30 × 25 1.13			25.4 × 35 1.12	30 × 30 1.12	35 × 20 1.11
270		25.4 × 40 1.41	30 × 30 1.28	35 × 20 1.30		25.4 × 35 1.24	30 × 30 1.27			25.4 × 40 1.26	30 × 30 1.27	35 × 25 1.27
330			30 × 35 1.40	35 × 30 1.49		25.4 × 40 1.39	30 × 35 1.43	35 × 25 1.49		25.4 × 45 1.44	30 × 35 1.43	35 × 30 1.44
390			30 × 40 1.44	35 × 30 1.64		25.4 × 50 1.55	30 × 40 1.60	35 × 30 1.66		25.4 × 50 1.51	30 × 40 1.60	35 × 30 1.63
470			30 × 45 1.71	35 × 35 1.82		25.4 × 50 1.72	30 × 45 1.81	35 × 30 1.83			30 × 45 1.81	35 × 35 1.80
560				35 × 40 2.00				35 × 35 2.07	← Case Size ∅ D × L (mm) ← Rated Ripple Current (Arms/105°C, 120Hz)			

RATINGS OF TDC Series

μF	V _{DC} ∅ D	420				450				500			
		22	25.4	30	35	22	25.4	30	35	22	25.4	30	35
68						22 × 20 0.50				22 × 35 0.50			
82		22 × 20 0.58				22 × 25 0.59	25.4 × 25 0.62			22 × 40 0.53	25.4 × 30 0.55		
100		22 × 25 0.66	25.4 × 25 0.69				25.4 × 25 0.70			22 × 45 0.61	25.4 × 35 0.64		
120		22 × 30 0.75	25.4 × 25 0.77	30 × 20 0.75			25.4 × 30 0.75			22 × 50 0.66	25.4 × 40 0.71	30 × 30 0.73	
150		22 × 40 0.86	25.4 × 30 0.88	30 × 25 0.88			25.4 × 30 0.88	30 × 25 0.87			25.4 × 45 0.81	30 × 35 0.80	
180		22 × 45 0.96	25.4 × 35 0.97	30 × 30 1.02	35 × 20 1.05		25.4 × 35 1.01	30 × 25 1.00			25.4 × 50 0.86	30 × 40 0.93	35 × 30 0.95
220		22 × 50 1.11	25.4 × 40 1.14	30 × 30 1.14	35 × 25 1.12			30 × 35 1.10				30 × 45 0.94	35 × 35 0.98
270			25.4 × 45 1.29	30 × 40 1.30	35 × 30 1.35			30 × 40 1.24	35 × 30 1.25			30 × 50 1.07	35 × 40 1.13
330				30 × 45 1.48	35 × 35 1.49				35 × 35 1.42			30 × 60 1.28	35 × 45 1.29
390					35 × 40 1.64				35 × 40 1.63				35 × 50 1.47
470					35 × 45 1.79				35 × 45 1.78	← Case Size ∅ D × L (mm) ← Rated Ripple Current (Arms/105°C, 120Hz)			35 × 60 1.71

TEA Series

• 105°C 2,000Hrs assured.

- Non-solvent proof.
- Height 15mm.
- For SMPS, Inverter.
- RoHS compliant.
- Halogen-free capacitors are also available.



SPECIFICATIONS

Item	Characteristics				
Rated Voltage Range	160 ~ 400 V _{DC}				
Operating Temperature Range	-25 ~ +105°C				
Capacitance Tolerance	±20%(M) (at 20°C, 120Hz)				
Leakage Current	I = 0.02CV(µA) or 3mA, whichever is smaller. Where, I: Leakage current(µA), C:Nominal capacitance(µF), V:Rated voltage(V _{DC}) (at 20°C, 5 minutes)				
※ Dissipation Factor(Tanδ)	<table border="1"> <tr> <td>Rated voltage(V_{DC})</td> <td>160 ~ 400</td> </tr> <tr> <td>Tanδ(Max.)</td> <td>0.20</td> </tr> </table> (at 20°C, 120Hz)	Rated voltage(V _{DC})	160 ~ 400	Tanδ(Max.)	0.20
Rated voltage(V _{DC})	160 ~ 400				
Tanδ(Max.)	0.20				
Temperature Characteristics (Max. Impedance ratio)	<table border="1"> <tr> <td>Rated voltage(V_{DC})</td> <td>160 ~ 400</td> </tr> <tr> <td>Z(-25°C)/Z(20°C)</td> <td>4</td> </tr> </table> (at 120Hz)	Rated voltage(V _{DC})	160 ~ 400	Z(-25°C)/Z(20°C)	4
Rated voltage(V _{DC})	160 ~ 400				
Z(-25°C)/Z(20°C)	4				
Load Life	<p>The following specifications shall be satisfied when the capacitors are restored to 20°C after the rated voltage is applied for 2,000 hours at 105°C.</p> <p>Capacitance change ≤ ±20% of the initial value Tanδ ≤ 200% of the initial specified value Leakage current ≤ The initial specified value</p>				
Shelf Life	<p>The following specifications shall be satisfied when the capacitors are restored to 20°C after the exposing them at 105°C for 1,000 hours without voltage applied. The rated voltage shall be applied to the capacitors for a minimum of 30 minutes, at least 24 hours and not more than 48 hours before the measurements.</p> <p>Capacitance change ≤ ±20% of the initial value Tanδ ≤ 200% of the initial specified value Leakage current ≤ The initial specified value</p>				
Others	Satisfied characteristics KS C IEC 60384-4				

※ For capacitors with CV products > 100,000 higher Tanδ value may apply.
 When the capacitance exceeds 1,000µF, 0.01 shall be added every 1,000µF increase.

RATED RIPPLE CURRENT

When capacitors are operated in any other conditions at 120Hz the maximum ripple current must be multiplied by the figure shown in the table.

Frequency multiplying factor

V _{DC}	Freq.(Hz)	60	120	300	1k	10k~
160~250V _{DC}		0.81	1.00	1.17	1.32	1.45
350~400V _{DC}		0.77	1.00	1.16	1.30	1.41

DIMENSIONS OF TEA Series

Unit(mm)

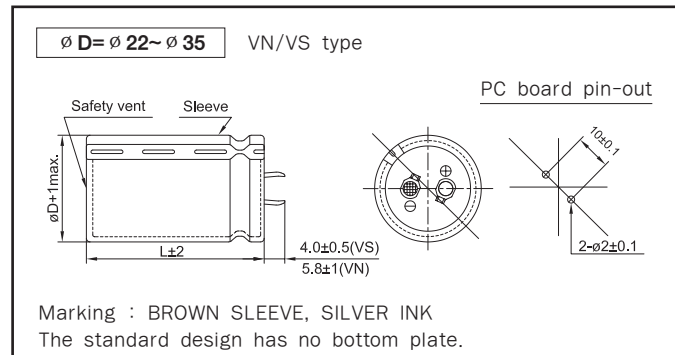

RATINGS OF TEA series

μF	V_{DC} ϕD	160				200			
		22	25.4	30	35	22	25.4	30	35
120						22 × 15 0.61			
150		22 × 15 0.68					25.4 × 15 0.73		
180			25.4 × 15 0.79					30 × 15 0.79	
220			25.4 × 15 0.88					30 × 15 0.90	
270				30 × 15 0.96					35 × 15 1.00
330				30 × 15 1.06					35 × 15 1.07
390					35 × 15 1.20				

μF	V_{DC} ϕD	250				400			
		22	25.4	30	35	22	25.4	30	35
39						22 × 15 0.35			
47							25.4 × 15 0.40		
56							25.4 × 15 0.44		
68								30 × 15 0.46	
82		22 × 15 0.50						30 × 15 0.51	
100			25.4 × 15 0.59						35 × 15 0.56
120			25.4 × 15 0.65						35 × 15 0.62
150				30 × 15 0.71					
180				30 × 15 0.79					
220					35 × 15 0.90	← Case Size $\phi D \times L$ (mm) ← Rated Ripple Current(Arms/105°C, 120Hz)			

RLS Series

• 85°C 3,000Hrs assured.

- Non-solvent proof.
- Long Life.
- For SMPS, Inverter.
- RoHS compliant.
- Halogen-free capacitors are also available.

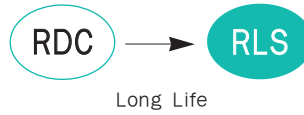

SPECIFICATIONS

Item	Characteristics						
Rated Voltage Range	160 ~ 500 V _{dc}						
Operating Temperature Range	-25 ~ +85°C						
Capacitance Tolerance	±20% (M) (at 20°C, 120Hz)						
Leakage Current	I = 0.02CV or 3mA, whichever is smaller. Where, I: Leakage current(µA) C: Nominal capacitance(µF) V: Rated voltage(V _{dc}) (at 20°C, 5 minutes)						
※ Dissipation Factor(Tanδ)	<table border="1"> <tr> <td>Rated Voltage(V_{dc})</td> <td>160~400</td> <td>450~500</td> </tr> <tr> <td>Tanδ(Max.)</td> <td>0.15</td> <td>0.20</td> </tr> </table> (at 20°C, 120Hz)	Rated Voltage(V _{dc})	160~400	450~500	Tanδ(Max.)	0.15	0.20
Rated Voltage(V _{dc})	160~400	450~500					
Tanδ(Max.)	0.15	0.20					
Temperature Characteristics (Max.Impedance ratio)	<table border="1"> <tr> <td>Rated Voltage(V_{dc})</td> <td>160~400</td> <td>450~500</td> </tr> <tr> <td>Z(-25°C)/Z(20°C)</td> <td>4</td> <td>8</td> </tr> </table> (at 120Hz)	Rated Voltage(V _{dc})	160~400	450~500	Z(-25°C)/Z(20°C)	4	8
Rated Voltage(V _{dc})	160~400	450~500					
Z(-25°C)/Z(20°C)	4	8					
Load Life	<p>The following specifications shall be satisfied when the capacitors are restored to 20°C after the rated voltage is applied for 3,000 hours at 85°C.</p> <p>Capacitance change ≤ ±20% of the initial value Tanδ ≤ 200% of the initial specified value Leakage Current ≤ The initial specified value</p>						
Shelf Life	<p>The following specifications shall be satisfied when the capacitors are restored to 20°C after the exposing them at 85°C. for 1,000 hours without voltage applied. The rated voltage shall be applied to the capacitors for a minimum of 30 minutes, at least 24 hours and not more than 48 hours before the measurement.</p> <p>Capacitance change ≤ ±15% of the initial value Tanδ ≤ 150% of the initial specified value Leakage Current ≤ The initial specified value</p>						
Others	Satisfied characteristics KS C IEC 60384-4						

※ For capacitors with CV products > 100,000 Higher Tanδ value may apply.
 When the capacitance exceeds 1,000µF, 0.01 shall be added every 1,000µF increase.

RATED RIPPLE CURRENT

When capacitors are operated in any other condition at 120Hz, the maximum ripple current must be multiplied by the figure shown in the table.

Frequency multiplying factor

V _{dc}	Freq.(Hz)	60	120	300	1k	10k~
160~250V _{dc}		0.81	1.00	1.17	1.32	1.45
350~500V _{dc}		0.77	1.00	1.16	1.30	1.41

DIMENSIONS OF RLS Series

Unit(mm)

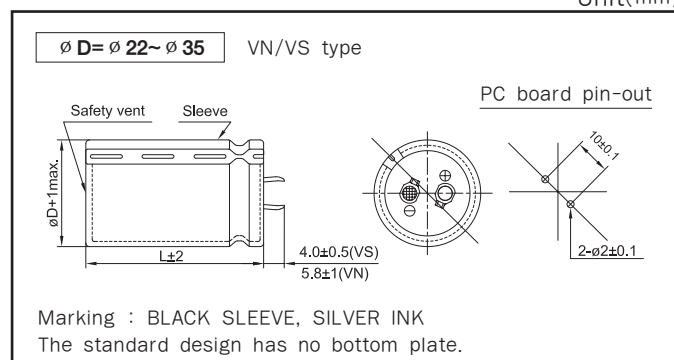

RATINGS OF RLS Series

V _{DC} μF / ∅ D	160				200				250			
	22	25.4	30	35	22	25.4	30	35	22	25.4	30	35
150									22 × 20 0.97			
180									22 × 20 1.06			
220					22 × 20 1.18				22 × 25 1.24	25.4 × 20 1.22		
270	22 × 20 1.30				22 × 20 1.37	25.4 × 20 1.35			22 × 30 1.54	25.4 × 20 1.32		
330	22 × 25 1.50				22 × 25 1.51	25.4 × 20 1.49			22 × 30 1.66	25.4 × 25 1.61	30 × 20 1.58	
390	22 × 25 1.62	25.4 × 20 1.62			22 × 30 1.73	25.4 × 25 1.71	30 × 20 1.71		22 × 35 1.88	25.4 × 30 1.88	30 × 25 1.86	35 × 20 1.71
470	22 × 30 1.86	25.4 × 25 1.86			22 × 30 1.97	25.4 × 25 1.95	30 × 20 1.88			25.4 × 35 2.15	30 × 25 2.05	35 × 20 1.88
560	22 × 30 2.15	25.4 × 25 2.15	30 × 20 2.05		22 × 40 2.18	25.4 × 30 2.15	30 × 25 2.15	35 × 20 2.05		25.4 × 35 2.35	30 × 30 2.36	35 × 25 2.35
680	22 × 35 2.35	25.4 × 30 2.33	30 × 25 2.33	35 × 20 2.26	22 × 40 2.48	25.4 × 30 2.48	30 × 25 2.48	35 × 20 2.36			30 × 30 2.71	35 × 25 2.58
820	22 × 40 2.68	25.4 × 30 2.65	30 × 25 2.64	35 × 20 2.49	22 × 45 2.81	25.4 × 40 2.79	30 × 30 2.80	35 × 25 2.83			30 × 35 2.98	35 × 30 2.88
1,000	22 × 45 3.02	25.4 × 35 3.00	30 × 30 2.96	35 × 25 3.31	22 × 50 3.28	25.4 × 40 3.28	30 × 35 3.15	35 × 30 3.26			30 × 40 3.56	35 × 35 3.48
1,200	22 × 50 3.47	25.4 × 40 3.43	30 × 30 3.41	35 × 25 3.40		25.4 × 45 3.61	30 × 35 3.61	35 × 30 3.57				

V _{DC} μF / ∅ D	350				400				450			
	22	25.4	30	35	22	25.4	30	35	22	25.4	30	35
47									22 × 20 0.54			
56									22 × 20 0.59			
68					22 × 20 0.65				22 × 25 0.71	25.4 × 20 0.68		
82	22 × 20 0.72				22 × 25 0.84	25.4 × 20 0.74			22 × 25 0.86	25.4 × 20 0.74	30 × 20 0.79	
100	22 × 25 0.80				22 × 25 0.99	25.4 × 20 0.82			22 × 30 0.95	25.4 × 25 0.97	30 × 20 0.87	
120	22 × 25 1.04	25.4 × 20 0.90			22 × 30 1.09	25.4 × 25 1.13	30 × 20 0.95		22 × 35 1.07	25.4 × 30 1.09	30 × 25 1.12	35 × 20 0.99
150	22 × 30 1.2	25.4 × 25 1.22	30 × 20 1.06		22 × 35 1.24	25.4 × 30 1.27	30 × 25 1.20		22 × 40 1.18	25.4 × 30 1.25	30 × 25 1.29	35 × 20 1.06
180	22 × 30 1.34	25.4 × 25 1.37	30 × 20 1.16		22 × 40 1.41	25.4 × 30 1.44	30 × 25 1.52	35 × 20 1.16	22 × 45 1.32	25.4 × 35 1.40	30 × 30 1.45	35 × 25 1.33
220	22 × 35 1.47	25.4 × 30 1.53	30 × 25 1.54	35 × 20 1.29	22 × 45 1.58	25.4 × 35 1.64	30 × 30 1.66	35 × 20 1.47	22 × 50 1.48	25.4 × 40 1.59	30 × 30 1.64	35 × 25 1.66
270		25.4 × 35 1.73	30 × 25 1.8	35 × 25 1.49	22 × 50 1.65	25.4 × 40 1.79	30 × 30 1.82	35 × 25 1.63		25.4 × 45 1.73	30 × 35 1.89	35 × 30 1.90
330			30 × 30 2.03	35 × 25 1.80		25.4 × 45 2.00	30 × 35 2.05	35 × 30 2.05		25.4 × 50 2.12	30 × 40 2.12	35 × 35 2.15
390			30 × 35 2.23	35 × 30 2.30		25.4 × 50 2.12	30 × 40 2.26	35 × 35 2.28			30 × 45 2.35	35 × 40 2.38
470			30 × 35 2.53	35 × 30 2.55			30 × 45 2.51	35 × 35 2.54			30 × 50 2.65	35 × 45 2.68
560				35 × 35 2.75			30 × 50 2.85	35 × 40 2.85				35 × 50 2.88
680				35 × 40 3.15	← Case Size ∅ D × L (mm) ← Rated Ripple Current (Arms/85°C, 120Hz)							

RATINGS OF RLS Series

μF	V_{DC} $\varnothing D$	500			
		22	25.4	30	35
56	22 × 35 0.42				
68	22 × 40 0.49	25.4 × 30 0.49			
82	22 × 45 0.57	25.4 × 35 0.58			
100	22 × 50 0.66	25.4 × 40 0.68	30 × 30 0.68		
120		25.4 × 45 0.78	30 × 35 0.79		
150		25.4 × 50 0.92	30 × 40 0.94	35 × 30 0.91	
180			30 × 45 1.08	35 × 35 1.06	
220			30 × 50 1.25	35 × 40 1.23	
270			30 × 60 1.51	35 × 45 1.43	
330				35 × 50 1.66	
390				35 × 60 1.95	

Case Size $\varnothing D \times L$ (mm) →
 Rated Ripple Current(Arms/85°C, 120Hz) →

RLB Series

• 85°C 3,000Hrs assured.

- Non-solvent proof.
- High Ripple, Low Temp.
- For high ripple current application such as air conditioning system
- RoHS compliant.
- Halogen-free capacitors are also available.



SPECIFICATIONS

Item	Characteristics									
Rated Voltage Range	400 ~ 500 V _{dc}									
Operating Temperature Range	-40 ~ +85°C									
Capacitance Tolerance	±10% (K) (at 20°C, 120Hz)									
Leakage Current	$I = 3\sqrt{CV} (\mu A)$ Where, I: Leakage current(μA) C: Nominal capacitance(μF) V: Rated voltage(V _{dc}) (at 20°C, 5 minutes)									
※ Dissipation Factor(Tanδ)	<table border="1"> <tr> <td>Rated Voltage(V_{dc})</td> <td>400</td> <td>450~500</td> </tr> <tr> <td>Tanδ(Max.)</td> <td>0.15</td> <td>0.20</td> </tr> </table> (at 20°C, 120Hz)	Rated Voltage(V _{dc})	400	450~500	Tanδ(Max.)	0.15	0.20			
Rated Voltage(V _{dc})	400	450~500								
Tanδ(Max.)	0.15	0.20								
Temperature Characteristics (Max.Impedance ratio)	<table border="1"> <tr> <td>Rated Voltage(V_{dc})</td> <td>400</td> <td>450~500</td> </tr> <tr> <td>Z(-25°C)/Z(20°C)</td> <td>4</td> <td>8</td> </tr> <tr> <td>Z(-40°C)/Z(20°C)</td> <td>8</td> <td>16</td> </tr> </table> (at 120Hz)	Rated Voltage(V _{dc})	400	450~500	Z(-25°C)/Z(20°C)	4	8	Z(-40°C)/Z(20°C)	8	16
Rated Voltage(V _{dc})	400	450~500								
Z(-25°C)/Z(20°C)	4	8								
Z(-40°C)/Z(20°C)	8	16								
Load Life	The following specifications shall be satisfied when the capacitors are restored to 20°C after the rated voltage with the rated ripple current is applied (the peak voltage shall not exceed the rated voltage) for 3,000 hours at 85°C Capacitance change ≤ ±20% of the initial value Tanδ ≤ 200% of the initial specified value Leakage current ≤ The initial specified value									
Shelf Life	The following specifications shall be satisfied when the capacitors are restored to 20°C after the exposing them at 85°C for 1,000hours without voltage applied. The rated voltage shall be applied to the capacitors for a minimum of 30 minutes, at least 24 hours and not more than 48 hours before the measurements. Capacitance change ≤ ±15% of the initial value Tanδ ≤ 150% of the initial specified value Leakage Current ≤ The initial specified value									
Others	Satisfied characteristics KS C IEC 60384-4									

※ For capacitors with CV products > 100,000 Higher Tanδ value may apply.
 When the capacitance exceeds 1,000μF, 0.01 shall be added every 1,000μF increase.

RATED RIPPLE CURRENT

When capacitors are operated in any other condition at 120Hz, the maximum ripple current must be multiplied by the figure shown in the table.

Frequency multiplying factor

V _{dc} \ Freq.(Hz)	60	120	300	1k	10k~
400~500V _{dc}	0.77	1.00	1.16	1.30	1.41

DIMENSIONS OF RLB Series

Unit(mm)

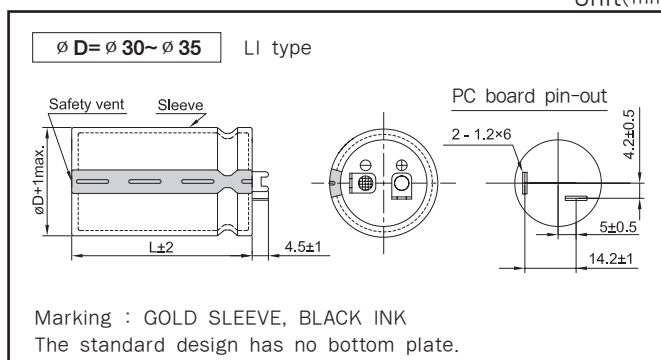

RATINGS OF RLB Series

V _{DC}	Capacitance (μF)	∅D×L(mm)	Rated Ripple Current (Arms/85°C, 120Hz)
400	100	30 × 20	1.01
	150	30 × 25	1.35
		35 × 20	
	220	30 × 30	1.84
		35 × 25	1.83
	270	30 × 35	2.11
	330	30 × 40	2.47
		35 × 30	2.45
	390	35 × 35	2.84
	470	30 × 50	3.32
		35 × 40	3.30
	560	35 × 45	3.70
	680	30 × 60	4.00
		35 × 50	
820	35 × 60	4.50	
450	82	30 × 20	0.94
	120	30 × 25	1.23
		35 × 20	
	180	30 × 30	1.67
		35 × 25	1.66
	220	30 × 35	1.95
	270	30 × 40	2.29
	330	35 × 35	2.64
	390	30 × 50	3.03
		35 × 40	3.01
	470	30 × 60	3.61
		35 × 45	3.50
	560	35 × 50	4.00
	680	35 × 60	4.40
	820	35 × 70	4.80
1,000	35 × 80	5.20	

V _{DC}	Capacitance (μF)	∅D×L(mm)	Rated Ripple Current (Arms/85°C, 120Hz)
500	82	30 × 25	0.69
	100	30 × 30	0.80
		35 × 25	0.79
	120	30 × 35	0.93
	150	30 × 40	1.09
		35 × 30	1.07
	180	35 × 35	1.24
		30 × 50	1.45
	220	35 × 40	1.44
		30 × 60	1.72
	270	35 × 45	1.68
		330	35 × 50
	390	35 × 60	2.26
	470	35 × 70	2.55

RLC Series

• 85°C 5,000Hrs assured.

- Non-solvent proof
- Long Life.
- For SMPS, Inverter.
- RoHS compliant.
- Halogen-free capacitors are also available.



SPECIFICATIONS

Item	Characteristics						
Rated Voltage Range	160 ~ 500 V _{dc}						
Operating Temperature Range	-25 ~ +85°C						
Capacitance Tolerance	±20% (M) (at 20°C, 120Hz)						
Leakage Current	I = 0.02CV or 3mA, whichever is smaller. Where, I: Leakage current(µA) C: Nominal capacitance(µF) V: Rated voltage(V _{dc}) (at 20°C, 5 minutes)						
※ Dissipation Factor(Tanδ)	<table border="1"> <tr> <td>Rated Voltage(V_{dc})</td> <td>160~400</td> <td>450~500</td> </tr> <tr> <td>Tanδ(Max.)</td> <td>0.15</td> <td>0.20</td> </tr> </table> (at 20°C, 120Hz)	Rated Voltage(V _{dc})	160~400	450~500	Tanδ(Max.)	0.15	0.20
Rated Voltage(V _{dc})	160~400	450~500					
Tanδ(Max.)	0.15	0.20					
Temperature Characteristics (Max.Impedance ratio)	<table border="1"> <tr> <td>Rated Voltage(V_{dc})</td> <td>160~400</td> <td>450~500</td> </tr> <tr> <td>Z(-25°C)/Z(20°C)</td> <td>4</td> <td>8</td> </tr> </table> (at 120Hz)	Rated Voltage(V _{dc})	160~400	450~500	Z(-25°C)/Z(20°C)	4	8
Rated Voltage(V _{dc})	160~400	450~500					
Z(-25°C)/Z(20°C)	4	8					
Load Life	<p>The following specifications shall be satisfied when the capacitors are restored to 20°C after the rated voltage with the rated ripple current is applied (the peak voltage shall not exceed the rated voltage) for 5,000 hours at 85°C.</p> <p>Capacitance change ≤ ±20% of the initial value Tanδ ≤ 200% of the initial specified value Leakage current ≤ The initial specified value</p>						
Shelf Life	<p>The following specifications shall be satisfied when the capacitors are restored to 20°C after the exposing them at 85°C for 1,000hours without voltage applied. The rated voltage shall be applied to the capacitors for a minimum of 30 minutes, at least 24 hours and not more than 48 hours before the measurements.</p> <p>Capacitance change ≤ ±15% of the initial value Tanδ ≤ 150% of the initial specified value Leakage Current ≤ The initial specified value</p>						
Others	Satisfied characteristics KS C IEC 60384-4						

※ For capacitors with CV products > 100,000 Higher Tanδ value may apply.
 When the capacitance exceeds 1,000µF, 0.01 shall be added every 1,000µF increase.

RATED RIPPLE CURRENT

When capacitors are operated in any other condition at 120Hz, the maximum ripple current must be multiplied by the figure shown in the table.

Frequency multiplying factor

V _{dc} \ Freq.(Hz)	60	120	300	1k	10k~
160~250	0.81	1.00	1.17	1.32	1.45
350~500	0.77	1.00	1.16	1.30	1.41

DIMENSIONS OF RLC Series

Unit(mm)

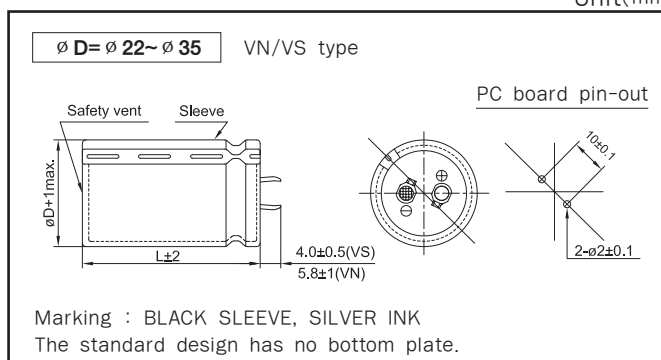



LARGE SIZED ALUMINUM ELECTROLYTIC CAPACITORS

RATINGS OF RLC Series

V _{DC}	Capacitance (μF)	∅D×L(mm)	Rated Ripple Current (Arms/85°C, 120Hz)	V _{DC}	Capacitance (μF)	∅D×L(mm)	Rated Ripple Current (Arms/85°C, 120Hz)	
160	270	22 × 25	1.46	250	680	30 × 40	3.08	
	390	22 × 30	1.69			35 × 30	2.66	
		25.4 × 25	1.69		820	30 × 45	3.37	
	470	22 × 35	1.95			35 × 35	3.20	
	560	22 × 40	2.21		1,000	30 × 50	3.51	
		25.4 × 30	2.11			35 × 40	3.54	
	680	30 × 25	2.11	1,200	35 × 45	3.78		
		22 × 45	2.49		35 × 50	4.08		
	820	25.4 × 35	2.47	350	82	22 × 25	0.76	
		22 × 50	2.86		120	22 × 30	1.12	
		25.4 × 40	2.83			25.4 × 25	1.14	
		30 × 30	2.68		150	22 × 35	1.27	
		35 × 25	2.99			22 × 40	1.40	
		1,000	25.4 × 45		3.13	180	25.4 × 30	1.45
	30 × 35		2.96		30 × 25		1.45	
	1,200	25.4 × 50	3.43		220	22 × 45	1.51	
		30 × 40	3.24			25.4 × 35	1.64	
		35 × 30	3.62		270	22 × 50	1.68	
1,500	30 × 45	3.62	25.4 × 40			1.83		
	35 × 35	4.05	30 × 30			1.91		
1,800	30 × 50	3.97	330		35 × 25	1.70		
	35 × 40	4.44			25.4 × 45	1.97		
2,200	35 × 45	4.75	30 × 35		2.15			
200	220	22 × 25	1.23		400	82	22 × 25	0.68
	330	22 × 30	1.59			120	22 × 30	0.89
		25.4 × 25	1.57				25.4 × 25	0.89
	390	22 × 35	1.84	150		22 × 35	1.07	
	470	22 × 40	1.99			22 × 40	1.24	
		25.4 × 30	1.97	180		25.4 × 30	1.18	
	30 × 25	1.97	30 × 25			1.22		
	560	22 × 45	2.32	220		22 × 45	1.44	
		25.4 × 35	2.30			25.4 × 35	1.39	
	680	25.4 × 40	2.54	270		22 × 50	1.68	
		30 × 30	2.55			25.4 × 40	1.63	
		35 × 25	2.57			30 × 30	1.61	
	820	25.4 × 45	2.98	330		35 × 25	1.65	
		30 × 35	2.85			25.4 × 45	1.90	
	1,000	30 × 40	3.15	390		30 × 35	1.89	
		35 × 30	3.15			30 × 40	2.18	
	1,200	30 × 45	3.45	470		35 × 30	2.12	
		35 × 35	3.45			30 × 45	2.51	
1,500	35 × 40	3.86	560	35 × 35	2.48			
1,800	35 × 50	4.23		30 × 50	3.00			
250	150	22 × 25	1.07	680	35 × 40	2.86		
	220	22 × 30	1.46		30 × 60	3.50		
		25.4 × 25	1.38	820	35 × 45	3.31		
	270	22 × 35	1.64		30 × 70	4.00		
	330	22 × 40	1.81	1,000	35 × 50	3.80		
		25.4 × 30	1.81		35 × 60	4.54		
	30 × 25	1.86	1,200	35 × 70	5.32			
	390	22 × 45		1.92				
		25.4 × 35	2.05					
	470	22 × 50	2.11					
		25.4 × 40	2.27					
		30 × 30	2.27					
560	35 × 25	2.18						
	25.4 × 45	2.42						
680	30 × 35	2.58						
	25.4 × 50	2.66						

RATINGS OF RLC Series

V _{DC}	Capacitance (μF)	∅D×L(mm)	Rated Ripple Current (Arms/85°C, 120Hz)
450	68	22 × 25	0.52
	100	22 × 30	0.68
		25.4 × 25	0.69
	120	22 × 35	0.80
		22 × 40	0.94
	150	25.4 × 30	0.91
		30 × 25	0.94
	180	22 × 45	1.09
		25.4 × 35	1.06
	220	22 × 50	1.26
		25.4 × 40	1.24
		30 × 30	1.22
		35 × 25	1.24
	270	25.4 × 45	1.45
		30 × 35	1.44
	330	30 × 40	1.69
		35 × 30	1.63
	390	30 × 45	1.93
		35 × 35	1.89
	470	30 × 50	2.22
35 × 40		2.19	
560	30 × 60	2.60	
	35 × 45	2.51	
680	30 × 70	3.10	
	35 × 50	2.89	
820	35 × 60	3.43	
1,000	35 × 70	4.06	

V _{DC}	Capacitance (μF)	∅D×L(mm)	Rated Ripple Current (Arms/85°C, 120Hz)
500	39	22 × 25	0.30
	56	22 × 30	0.39
		25.4 × 25	0.39
	68	22 × 35	0.46
		22 × 40	0.53
	82	25.4 × 30	0.51
		30 × 25	0.53
	100	22 × 45	0.62
		25.4 × 35	0.60
	120	22 × 50	0.71
		25.4 × 40	0.70
		30 × 30	0.69
		35 × 25	0.70
	150	25.4 × 45	0.83
		30 × 35	0.82
	180	30 × 40	0.95
		35 × 30	0.92
	220	30 × 45	1.10
		35 × 35	1.08
	270	30 × 60	1.31
35 × 40		1.27	
330	30 × 70	1.64	
	35 × 50	1.54	
390	35 × 60	1.81	
470	35 × 70	2.13	

TLA Series

• 105°C 3,000Hrs assured.

- Non-solvent proof.
- Long Life.
- For SMPS, Inverter.
- RoHS compliant.
- Halogen-free capacitors are also available.



SPECIFICATIONS

Item	Characteristics						
Rated Voltage Range	160 ~ 500 V _{DC}						
Operating Temperature Range	-25 ~ +105°C						
Capacitance Tolerance	±20%(M) (at 20°C, 120Hz)						
Leakage Current	I = 0.02CV or 3mA, whichever is smaller. Where, I: Leakage Current(µA), C: Nominal capacitance(µF), V: Rated voltage(V _{DC}) (at 20°C, 5minutes)						
※ Dissipation Factor(Tanδ)	<table border="1"> <tr> <td>Rated voltage(V_{DC})</td> <td>160 ~ 500</td> </tr> <tr> <td>Tanδ(Max.)</td> <td>0.20</td> </tr> </table> (at 20°C, 120Hz)	Rated voltage(V _{DC})	160 ~ 500	Tanδ(Max.)	0.20		
Rated voltage(V _{DC})	160 ~ 500						
Tanδ(Max.)	0.20						
Temperature Characteristics (Max. Impedance ratio)	<table border="1"> <tr> <td>Rated voltage(V_{DC})</td> <td>160 ~ 400</td> <td>420 ~ 500</td> </tr> <tr> <td>Z(-25°C)/Z(20°C)</td> <td>4</td> <td>8</td> </tr> </table> (at 120Hz)	Rated voltage(V _{DC})	160 ~ 400	420 ~ 500	Z(-25°C)/Z(20°C)	4	8
Rated voltage(V _{DC})	160 ~ 400	420 ~ 500					
Z(-25°C)/Z(20°C)	4	8					
Load Life	<p>The following specifications shall be satisfied when the capacitors are restored to 20°C after the rated voltage is applied for 3,000 hours at 105°C.</p> <p>Capacitance change ≤ ±20% of the initial value Tanδ ≤ 200% of the initial specified value Leakage current ≤ The initial specified value</p>						
Shelf Life	<p>The following specifications shall be satisfied when the capacitors are restored to 20°C after the exposing them at 105°C for 1,000 hours without voltage applied. The rated voltage shall be applied to the capacitors for a minimum of 30 minutes, at least 24 hours and not more than 48 hours before the measurements.</p> <p>Capacitance change ≤ ±20% of the initial value Tanδ ≤ 200% of the initial specified value Leakage current ≤ The initial specified value</p>						
Others	Satisfied characteristics KS C IEC 60384-4						

※ For capacitors with CV products > 100,000 higher Tanδ value may apply.
 When the capacitance exceeds 1,000µF, 0.01 shall be added every 1,000µF increase.

RATED RIPPLE CURRENT

When capacitor are operated in any other condition at 120Hz, the maximum ripple current must be multiplied by the figure shown in the table.

Frequency multiplying factor

V _{DC} \ Freq.(Hz)	60	120	300	1k	10k~
160~250V _{DC}	0.81	1.00	1.17	1.32	1.45
350~500V _{DC}	0.77	1.00	1.16	1.30	1.41

DIMENSIONS OF TLA Series

Unit(mm)

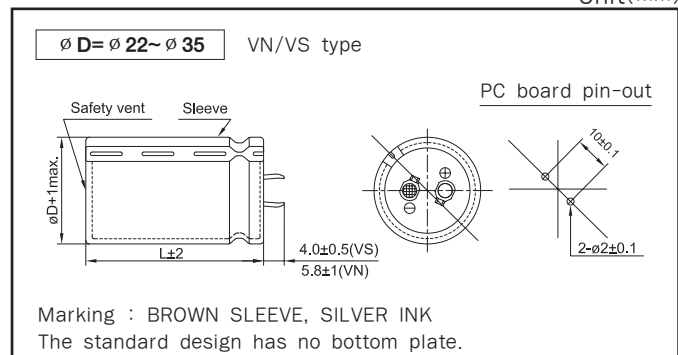

RATINGS OF TLA Series

μF \ Vdc / ØD	160				200				250			
	22	25.4	30	35	22	25.4	30	35	22	25.4	30	35
180									22 × 25 0.78			
220									22 × 30 1.00	25.4 × 25 0.95		
270					22 × 25 1.10				22 × 30 1.18	25.4 × 25 1.18		
330	22 × 25 1.20				22 × 30 1.25	25.4 × 25 1.25			22 × 35 1.30	25.4 × 35 1.30	30 × 25 1.30	
390	22 × 25 1.26	25.4 × 25 1.30			22 × 30 1.35	25.4 × 25 1.35			22 × 40 1.49	25.4 × 35 1.49	30 × 25 1.49	
470	22 × 30 1.33	25.4 × 25 1.33			22 × 40 1.50	25.4 × 30 1.50	30 × 25 1.50		22 × 45 1.65	25.4 × 35 1.65	30 × 25 1.65	35 × 25 1.65
560	22 × 35 1.60	25.4 × 30 1.60	30 × 25 1.60		22 × 45 1.67	25.4 × 30 1.60	30 × 25 1.60		22 × 50 1.67	25.4 × 40 1.80	30 × 30 1.80	35 × 25 1.80
680	22 × 40 1.82	25.4 × 30 1.82	30 × 25 1.82		22 × 45 1.78	25.4 × 35 1.78	30 × 30 1.78	35 × 25 1.78		25.4 × 50 2.00	30 × 35 2.00	35 × 30 2.00
820	22 × 45 2.04	25.4 × 35 2.04	30 × 30 2.04	35 × 25 2.04		25.4 × 45 2.04	30 × 30 2.04	35 × 25 2.04		25.4 × 60 2.20	30 × 40 2.30	35 × 35 2.30
1,000	22 × 50 2.25	25.4 × 40 2.25	30 × 30 2.25	35 × 25 2.25		25.4 × 50 2.30	30 × 35 2.30	35 × 30 2.30			30 × 50 2.47	35 × 40 2.47
1,200		25.4 × 45 2.49	30 × 35 2.49	35 × 30 2.49		25.4 × 60 2.66	30 × 40 2.65	35 × 35 2.65			30 × 60 2.85	35 × 45 2.60
1,500		25.4 × 60 2.97	30 × 40 2.84	35 × 30 2.84			30 × 50 3.08	35 × 40 3.08				35 × 50 3.00
1,800			30 × 45 3.32	35 × 35 3.00			30 × 60 3.49	35 × 45 3.48				35 × 60 3.42
2,200			30 × 60 3.86	35 × 45 3.50				35 × 50 3.78	← Case Size ØD×L(mm) ← Rated Ripple Current(Arms/105°C, 120Hz)			

μF \ Vdc / ØD	350				400			
	22	25.4	30	35	22	25.4	30	35
68					22 × 25 0.55			
82	22 × 25 0.55				22 × 25 0.64			
100	22 × 25 0.69				22 × 30 0.70	25.4 × 25 0.70		
120	22 × 30 0.75	25.4 × 25 0.75			22 × 35 0.75	25.4 × 25 0.75	30 × 25 0.80	
150	22 × 35 0.82	25.4 × 30 0.83	30 × 25 0.82		22 × 40 0.88	25.4 × 30 0.88	30 × 25 0.88	
180	22 × 40 0.92	25.4 × 30 0.92	30 × 25 0.90		22 × 45 0.98	25.4 × 35 0.98	30 × 30 0.98	35 × 25 0.98
220	22 × 45 1.05	25.4 × 35 1.04	30 × 30 1.02	35 × 25 1.04	22 × 50 1.10	25.4 × 40 1.10	30 × 30 1.10	35 × 25 1.0
270	22 × 50 1.16	25.4 × 40 1.18	30 × 30 1.17	35 × 25 1.20		25.4 × 45 1.22	30 × 35 1.22	35 × 30 1.22
330		25.4 × 45 1.29	30 × 35 1.34	35 × 30 1.22		25.4 × 50 1.44	30 × 40 1.44	35 × 30 1.44
390		25.4 × 50 1.51	30 × 40 1.51	35 × 35 1.47		25.4 × 60 1.51	30 × 45 1.60	35 × 35 1.60
470		25.4 × 60 1.66	30 × 45 1.65	35 × 35 1.69			30 × 50 1.90	35 × 40 1.90
560			30 × 50 1.85	35 × 40 1.90			30 × 60 2.10	35 × 45 2.12
680			30 × 60 2.15	35 × 50 1.99				35 × 60 2.27

RATINGS OF TLA Series

V _{dc} μF ∅D	420				450			
	22	25.4	30	35	22	25.4	30	35
56					22 × 25 0.40			
68	22 × 25 0.50				22 × 30 0.53	25.4 × 25 0.50		
82	22 × 25 0.64	25.4 × 25 0.58			22 × 30 0.64	25.4 × 25 0.64		
100	22 × 30 0.70	25.4 × 25 0.70			22 × 35 0.69	25.4 × 30 0.69	30 × 25 0.64	
120	22 × 35 0.75	25.4 × 30 0.75	30 × 25 0.73		22 × 40 0.80	25.4 × 30 0.80	30 × 25 0.80	35 × 25 0.73
150	22 × 40 0.88	25.4 × 35 0.88	30 × 25 0.88		22 × 45 0.88	25.4 × 35 0.88	30 × 30 0.88	35 × 25 0.75
180	22 × 45 0.95	25.4 × 35 0.95	30 × 30 0.95	35 × 25 0.94	22 × 50 1.00	25.4 × 40 1.00	30 × 30 1.00	
220	22 × 50 1.10	25.4 × 45 1.10	30 × 35 1.10	35 × 25 1.10		25.4 × 45 1.12	30 × 35 1.12	35 × 30 1.12
270		25.4 × 50 1.22	30 × 40 1.22	35 × 30 1.22		25.4 × 50 1.18	30 × 40 1.28	35 × 35 1.28
330		25.4 × 60 1.41	30 × 45 1.45	35 × 35 1.45			30 × 50 1.45	35 × 40 1.45
390			30 × 50 1.55	35 × 40 1.55			30 × 60 1.51	35 × 40 1.55
470			30 × 60 1.79	35 × 45 1.90	← Case Size ∅D×L(mm) ← Rated Ripple Current(Arms/105°C, 120Hz)			

V _{dc} μF ∅D	500			
	22	25.4	30	35
56	22 × 35 0.46	25.4 × 30 0.46	30 × 30 0.48	
68	22 × 40 0.50	25.4 × 35 0.53	30 × 30 0.55	
82	22 × 45 0.56	25.4 × 35 0.58	30 × 35 0.58	
100		25.4 × 40 0.65	30 × 35 0.66	
120		25.4 × 45 0.75	30 × 40 0.76	35 × 30 0.78
150			30 × 45 0.80	35 × 35 0.81
180			30 × 50 0.90	35 × 40 0.93
220			30 × 60 1.10	35 × 45 1.11
270				35 × 50 1.28
330				35 × 60 1.50

TLS Series

• 105°C 3,000Hrs assured.

- Non-solvent proof.
- Downsized.
- High Ripple Capability.
- For SMPS, Inverter.
- RoHS compliant.
- Halogen-free capacitors are also available.
- AEC-Q200 compliant : Please contact us for more details, test data, information.



SPECIFICATIONS

Item	Characteristics						
Rated Voltage Range	160 ~ 550 V _{DC}						
Operating Temperature Range	-25 ~ +105°C						
Capacitance Tolerance	±20%(M) (at 20°C, 120Hz)						
Leakage Current	I=0.02CV or 3mA, whichever is smaller. Where, I: Leakage Current(µA), C: Nominal capacitance(µF), V: Rated voltage(V _{DC}) (at 20°C, 5minutes)						
※ Dissipation Factor(Tanδ)	<table border="1"> <tr> <td>Rated voltage(V_{DC})</td> <td>160~400</td> <td>450~550</td> </tr> <tr> <td>Tanδ(Max.)</td> <td>0.15</td> <td>0.20</td> </tr> </table> (at 20°C, 120Hz)	Rated voltage(V _{DC})	160~400	450~550	Tanδ(Max.)	0.15	0.20
Rated voltage(V _{DC})	160~400	450~550					
Tanδ(Max.)	0.15	0.20					
Temperature Characteristics (Max. Impedance ratio)	<table border="1"> <tr> <td>Rated voltage(V_{DC})</td> <td>160~400</td> <td>450~550</td> </tr> <tr> <td>Z(-25°C)/Z(20°C)</td> <td>4</td> <td>8</td> </tr> </table> (at 120Hz)	Rated voltage(V _{DC})	160~400	450~550	Z(-25°C)/Z(20°C)	4	8
Rated voltage(V _{DC})	160~400	450~550					
Z(-25°C)/Z(20°C)	4	8					
Load Life	The following specifications shall be satisfied when the capacitors are restored to 20°C after the rated voltage is applied for 3,000 hours at 105°C. Capacitance change ≤ ±20% of the initial value Tanδ ≤ 200% of the initial specified value Leakage current ≤ The initial specified value						
Shelf Life	The following specifications shall be satisfied when the capacitors are restored to 20°C after the exposing them at 105°C for 1,000 hours without voltage applied. The rated voltage shall be applied to the capacitors for a minimum of 30 minutes, at least 24 hours and not more than 48 hours before the measurements. Capacitance change ≤ ±20% of the initial value Tanδ ≤ 200% of the initial specified value Leakage current ≤ The initial specified value						
Others	Satisfied characteristics KS C IEC 60384-4						

※For capacitors with CV products >100,000 higher Tanδ value may apply.
When the capacitance exceeds 1,000µF, 0.01 shall be added every 1,000µF increase.

RATED RIPPLE CURRENT

When capacitor are operated in any other condition at 120Hz, the maximum ripple current must be multiplied by the figure shown in the table.

Frequency multiplying factor

V _{DC} \ Freq.(Hz)	60	120	300	1k	10k~
160~250V _{DC}	0.81	1.00	1.17	1.32	1.45
315~550V _{DC}	0.77	1.00	1.16	1.30	1.41

DIMENSIONS OF TLS Series

Unit(mm)

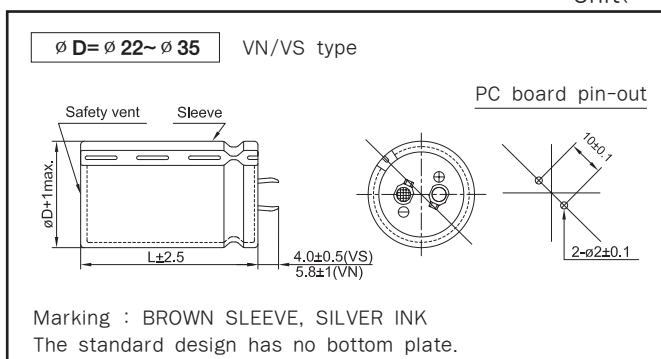

RATINGS OF TLS Series

Vdc μF / ØD	160				200				250			
	22	25.4	30	35	22	25.4	30	35	22	25.4	30	35
270									22 × 25 1.11			
330					22 × 25 1.23				22 × 30 1.29			
390					22 × 30 1.40				22 × 35 1.44	25.4 × 25 1.40		
470	22 × 25 1.47				22 × 30 1.54				22 × 40 1.61	25.4 × 30 1.57		
560	22 × 30 1.68				22 × 35 1.72	25.4 × 25 1.67			22 × 45 1.79	25.4 × 35 1.79	30 × 25 1.87	
680	22 × 35 1.86	25.4 × 25 1.84			22 × 40 1.94	25.4 × 30 1.89	30 × 25 2.05		22 × 50 2.02	25.4 × 40 2.02	30 × 30 2.08	35 × 25 2.19
820	22 × 40 2.12	25.4 × 30 2.08			22 × 45 2.17	25.4 × 35 2.17	30 × 30 2.28			25.4 × 45 2.26	30 × 35 2.34	35 × 30 2.44
1,000	22 × 45 2.40	25.4 × 35 2.40	30 × 25 2.50			25.4 × 40 2.45	30 × 30 2.52	35 × 25 2.66		25.4 × 50 2.53	30 × 40 2.66	35 × 30 2.70
1,200	22 × 50 2.69	25.4 × 40 2.68	30 × 30 2.77	35 × 25 2.91		25.4 × 45 2.78	30 × 35 2.83	35 × 30 2.96			30 × 45 2.99	35 × 35 3.00
1,500		25.4 × 45 3.05	30 × 35 3.17	35 × 30 3.30			30 × 40 3.26	35 × 35 3.36				35 × 40 3.48
1,800		25.4 × 50 3.40	30 × 40 3.57	35 × 30 3.62			30 × 50 3.72	35 × 40 3.81				35 × 50 3.98
2,200			30 × 45 4.05	35 × 35 4.07				35 × 45 4.32				
2,700			30 × 50 4.56	35 × 40 4.67				35 × 50 4.88				
3,300				35 × 50 5.40								

Vdc μF / ØD	315				400				450			
	22	25.4	30	35	22	25.4	30	35	22	25.4	30	35
100									22 × 25 0.70			
120					22 × 25 0.77				22 × 30 0.81			
150					22 × 30 0.90				22 × 35 0.92	25.4 × 25 0.90		
180	22 × 25 0.95				22 × 35 1.02	25.4 × 25 0.99			22 × 40 1.02	25.4 × 35 1.05	30 × 25 1.06	
220	22 × 30 1.10				22 × 40 1.15	25.4 × 30 1.13			22 × 45 1.17	25.4 × 35 1.16	30 × 30 1.18	
270	22 × 35 1.24	25.4 × 25 1.21			22 × 45 1.29	25.4 × 35 1.30	30 × 25 1.29			25.4 × 40 1.32	30 × 30 1.30	35 × 25 1.37
330	22 × 40 1.40	25.4 × 30 1.38	30 × 25 1.43		22 × 50 1.47	25.4 × 40 1.47	30 × 30 1.45			25.4 × 45 1.48	30 × 35 1.51	35 × 30 1.54
390	22 × 45 1.56	25.4 × 35 1.57	30 × 30 1.57			25.4 × 45 1.63	30 × 35 1.61	35 × 25 1.65		25.4 × 50 1.65	30 × 40 1.65	35 × 30 1.67
470	22 × 50 1.70	25.4 × 40 1.76	30 × 30 1.73	35 × 25 1.82		25.4 × 50 1.82	30 × 40 1.82	35 × 30 1.85			30 × 45 1.86	35 × 35 1.87
560		25.4 × 45 1.96	30 × 35 1.93	35 × 30 2.02			30 × 45 2.04	35 × 35 2.05				35 × 40 2.05
680			30 × 40 2.19	35 × 30 2.20			30 × 50 2.30	35 × 40 2.34				35 × 50 2.44
820			30 × 45 2.47	35 × 35 2.48				35 × 45 2.63				
1,000				35 × 40 2.83				35 × 50 2.96				
1,200				35 × 45 3.18								

← Case Size ØD×L(mm)
 ← Rated Ripple Current(Arms/105°C, 120Hz)

RATINGS OF TLS Series

μF	V _{bc} ∅ D	500				550		
		22	25.4	30	35	25.4	30	35
56	22 × 35 0.41							
68	22 × 40 0.48	25.4 × 30 0.46						
82	22 × 45 0.56	25.4 × 35 0.54			25.4 × 40 0.52			
100	22 × 50 0.64	25.4 × 40 0.63	30 × 30 0.61		25.4 × 50 0.60	30 × 35 0.55		
120		25.4 × 45 0.73	30 × 35 0.72		25.4 × 50 0.72	30 × 40 0.70		
150		25.4 × 50 0.78	30 × 40 0.85	35 × 30 0.83		30 × 45 0.80	35 × 35 0.75	
180			30 × 45 0.98	35 × 35 0.96		30 × 50 0.90	35 × 40 0.93	
220			30 × 50 1.03	35 × 40 1.13		30 × 60 0.95	35 × 50 0.95	
270			30 × 60 1.24	35 × 45 1.31		30 × 70 1.00	35 × 55 1.05	
330				35 × 50 1.38			35 × 60 1.15	
390		Case Size ∅ D × L (mm) →		35 × 60			35 × 70	
		Rated Ripple Current (Arms/105°C) →		1.63			1.50	

TLG Series

• 105°C 3,000Hrs assured.

- Non-solvent proof
- High Ripple, Low Temp.
- For SMPS, Inverter.
- RoHS compliant.
- Halogen-free capacitors are also available.
- AEC-Q200 compliant : Please contact us for more details, test data, information.



SPECIFICATIONS

Item	Characteristics		
Rated Voltage Range	160 ~ 500 V _{DC}		
Operating Temperature Range	-40 ~ +105°C		
Capacitance Tolerance	±20%(M) (at 20°C, 120Hz)		
Leakage Current	$I = 3\sqrt{CV} (\mu A)$ Where, I: Leakage Current(μA), C: Nominal capacitance(μF), V: Rated voltage(V _{DC}) (at 20°C, 5minutes)		
※ Dissipation Factor(Tanδ)	Rated voltage(V _{DC})	160~400	450~500
	Tanδ(Max.)	0.15	0.20
	(at 20°C, 120Hz)		
Temperature Characteristics (Max. Impedance ratio)	Rated voltage(V _{DC})	160~400	450~500
	Z(-25°C)/Z(20°C)	4	8
	Z(-40°C)/Z(20°C)	8	16
	(at 120Hz)		
Load Life	The following specifications shall be satisfied when the capacitors are restored to 20°C after the rated voltage with the rated ripple current is applied (the peak voltage shall not exceed the rated voltage) for 3,000 hours at 105°C Capacitance change ≤ ±20% of the initial value Tanδ ≤ 200% of the initial specified value Leakage current ≤ The initial specified value		
Shelf Life	The following specifications shall be satisfied when the capacitors are restored to 20°C after the exposing them at 105°C for 1,000hours without voltage applied. The rated voltage shall be applied to the capacitors for a minimum of 30 minutes, at least 24 hours and not more than 48 hours before the measurements. Capacitance change ≤ ±20% of the initial value Tanδ ≤ 200% of the initial specified value Leakage current ≤ The initial specified value		
Others	Satisfied characteristics KS C IEC 60384-4		

※ For capacitors with CV products > 100,000 higher Tanδ value may apply.
 When the capacitance exceeds 1,000μF, 0.01 shall be added every 1,000μF increase.

RATED RIPPLE CURRENT

When capacitor are operated in any other condition at 120Hz, the maximum ripple current must be multiplied by the figure shown in the table.

Frequency multiplying factor

V _{DC} \ Freq.(Hz)	60	120	300	1k	10k~
160~250	0.81	1.00	1.17	1.32	1.45
350~500	0.77	1.00	1.16	1.30	1.41

DIMENSIONS OF TLG Series

Unit(mm)

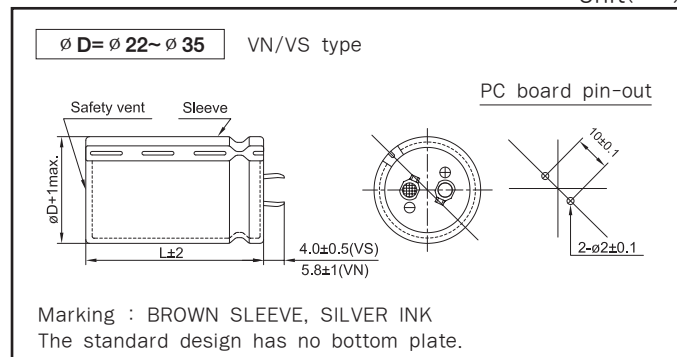

RATINGS OF TLG Series

V _{DC}	Capacitance (μF)	∅D×L(mm)	Rated Ripple Current (Arms/105°C,120Hz)
160	330	22 × 25	1.20
	470	22 × 30	1.47
		25.4 × 25	1.46
	560	22 × 35	1.66
	680	22 × 40	1.87
		25.4 × 30	1.82
		30 × 25	1.85
	820	22 × 45	2.11
		25.4 × 35	2.06
	1,000	22 × 50	2.31
		25.4 × 40	2.28
		30 × 30	2.27
		35 × 25	2.29
	1,200	25.4 × 45	2.57
		30 × 35	2.57
	1,500	30 × 40	2.96
35 × 30		2.91	
1,800	30 × 45	3.34	
	35 × 35	3.30	
2,200	35 × 45	3.78	
2,700	35 × 50	4.07	
200	270	22 × 25	1.15
	390	22 × 30	1.43
		25.4 × 25	1.42
	470	22 × 35	1.60
	560	22 × 40	1.80
		25.4 × 30	1.75
	680	30 × 25	1.80
		22 × 45	2.04
	820	25.4 × 35	1.99
		22 × 50	2.17
		25.4 × 40	2.26
		30 × 30	2.26
	1,000	35 × 25	2.27
		25.4 × 50	2.48
		30 × 35	2.49
	1,200	30 × 40	2.81
35 × 30		2.77	
1,500	30 × 50	3.23	
	35 × 40	3.32	
1,800	35 × 45	3.75	
2,200	35 × 50	4.01	
250	180	22 × 25	0.97
	270	22 × 30	1.23
		25.4 × 25	1.22
	330	22 × 35	1.39
	390	22 × 40	1.55
		25.4 × 30	1.51
	470	30 × 25	1.54
		22 × 45	1.75
	560	25.4 × 35	1.71
		22 × 50	1.96
		25.4 × 40	1.92
		30 × 30	1.91
	680	35 × 25	1.93
		25.4 × 50	2.24
		30 × 35	2.18
	820	35 × 30	2.22
30 × 40		2.47	
35 × 35		2.52	
1,000	30 × 50	2.89	
	35 × 40	2.87	
	1,200	35 × 45	3.25
1,500	35 × 50	3.73	

V _{DC}	Capacitance (μF)	∅D×L(mm)	Rated Ripple Current (Arms/105°C,120Hz)
350	100	22 × 25	0.73
	150	22 × 30	0.91
		25.4 × 25	0.91
	180	22 × 35	1.03
	220	22 × 40	1.16
		25.4 × 30	1.14
		30 × 25	1.16
	270	22 × 50	1.36
		25.4 × 40	1.33
		30 × 30	1.33
		35 × 25	1.34
	330	25.4 × 45	1.52
		25.4 × 50	1.69
	390	30 × 35	1.65
		35 × 30	1.68
	470	30 × 40	1.87
35 × 35		1.91	
560	30 × 50	2.16	
	35 × 40	2.15	
680	35 × 45	2.44	
820	35 × 50	2.76	
400	100	22 × 25	0.73
	120	22 × 30	0.82
		25.4 × 25	0.81
	150	22 × 35	0.94
	180	22 × 40	1.05
		25.4 × 30	1.03
	220	30 × 25	1.05
		22 × 45	1.20
	270	25.4 × 35	1.17
		22 × 50	1.36
		25.4 × 40	1.33
		30 × 30	1.33
	330	35 × 25	1.34
		25.4 × 45	1.52
		30 × 35	1.52
	390	25.4 × 50	1.69
30 × 40		1.70	
470	35 × 30	1.68	
	30 × 45	1.93	
560	35 × 35	1.91	
	30 × 50	2.16	
680	35 × 40	2.15	
	35 × 45	2.44	
820	35 × 50	2.76	
450	68	22 × 25	0.57
	100	22 × 30	0.71
		25.4 × 25	0.71
	120	22 × 35	0.80
	150	22 × 40	0.92
		25.4 × 30	0.90
	180	30 × 25	0.92
		22 × 45	1.04
	220	25.4 × 35	1.01
		25.4 × 40	1.15
		30 × 30	1.15
	270	35 × 25	1.16
		25.4 × 50	1.35
		30 × 40	1.36
	330	35 × 30	1.34
		30 × 45	1.55
35 × 35		1.53	
390	30 × 50	1.73	
	35 × 40	1.72	

RATINGS OF TLG Series

V _{DC}	Capacitance (μF)	∅D×L(mm)	Rated Ripple Current (Arms/105°C,120Hz)
450	470	35 × 45	1.95
	560	35 × 50	2.18
500	47	22 × 25	0.43
		22 × 30	0.52
	56	25.4 × 25	0.50
		22 × 35	0.60
	68	22 × 40	0.65
		25.4 × 30	0.67
		30 × 25	0.72
	100	22 × 45	0.74
		25.4 × 35	0.77
	120	22 × 50	0.85
		25.4 × 40	0.85
		30 × 30	0.86
		35 × 25	0.88
	150	25.4 × 45	0.98
		30 × 35	0.97
	180	25.4 × 50	1.12
		30 × 40	1.13
		35 × 30	1.15
	220	30 × 45	1.22
		35 × 35	1.24
270	30 × 50	1.34	
	35 × 40	1.37	
330	35 × 45	1.62	
390	35 × 50	1.84	

TLJ Series

• 105°C 3,000Hrs assured.

- Non-solvent proof
- High Ripple, Low Temp.
- For SMPS, Inverter.
- RoHS compliant.
- Halogen-free capacitors are also available.

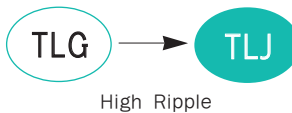

SPECIFICATIONS

Item	Characteristics		
Rated Voltage Range	400 ~ 500 V _{DC}		
Operating Temperature Range	-40 ~ +105°C		
Capacitance Tolerance	±20%(M) (at 20°C, 120Hz)		
Leakage Current	$I = 3\sqrt{CV}$ or 3mA, Whichever is smaller. Where, I: Leakage Current(µA), C: Nominal capacitance(µF), V: Rated voltage(V _{DC}) (at 20°C, 5minutes)		
*Dissipation Factor(Tanδ)	Rated voltage(V _{DC})	400	420 ~ 500
	Tanδ(Max.)	0.15	0.20
Temperature Characteristics (Max. Impedance ratio)	Rated voltage(V _{DC})	400	420 ~ 500
	Z(-25°C)/Z(20°C)	4	8
	Z(-40°C)/Z(20°C)	8	16
	(at 120Hz)		
Load Life	The following specifications shall be satisfied when the capacitors are restored to 20°C after the rated voltage with the rated ripple current is applied (the peak voltage shall not exceed the rated voltage) for 3,000 hours at 105°C Capacitance change ≤ ±20% of the initial value Tanδ ≤ 200% of the initial specified value Leakage current ≤ The initial specified value		
Shelf Life	The following specifications shall be satisfied when the capacitors are restored to 20°C after the exposing them at 105°C for 1,000hours without voltage applied. The rated voltage shall be applied to the capacitors for a minimum of 30 minutes, at least 24 hours and not more than 48 hours before the measurements. Capacitance change ≤ ±20% of the initial value Tanδ ≤ 200% of the initial specified value Leakage current ≤ The initial specified value		
Others	Satisfied characteristics KS C IEC 60384-4		

※For capacitors with CV products >100,000 higher Tanδ value may apply.
 When the capacitance exceeds 1,000µF, 0.01 shall be added every 1,000µF increase.

RATED RIPPLE CURRENT

When capacitor are operated in any other condition at 120Hz, the maximum ripple current must be multiplied by the figure shown in the table.

Frequency multiplying factor

V _{DC}	Freq.(Hz)	60	120	300	1k	10k~
400~500		0.77	1.00	1.16	1.30	1.41

DIMENSIONS OF TLJ Series

Unit(mm)

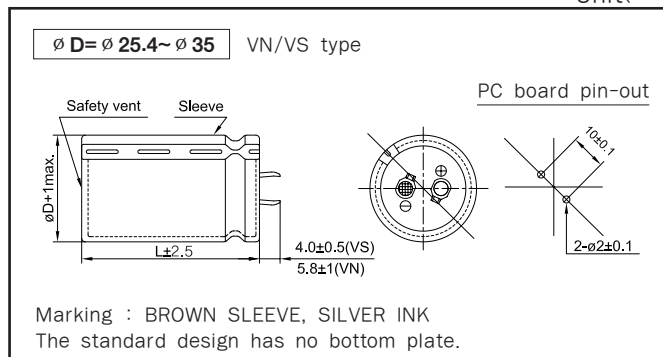

RATINGS OF TLJ Series

V _{DC}	Capacitance (μF)	∅D×L(mm)	Rated Ripple Current (Arms/105°C,120Hz)	V _{DC}	Capacitance (μF)	∅D×L(mm)	Rated Ripple Current (Arms/105°C,120Hz)
400	120	25.4 × 25	1.05	450	100	25.4 × 25	0.92
	180	25.4 × 30	1.34		150	25.4 × 35	1.17
		30 × 25	1.37			30 × 25	1.20
	220	25.4 × 35	1.52		180	25.4 × 40	1.31
	270	25.4 × 40	1.73		220	25.4 × 45	1.50
		30 × 30	1.73			30 × 35	1.50
		35 × 25	1.74			35 × 25	1.51
	330	25.4 × 50	1.98		270	25.4 × 50	1.76
		30 × 35	1.96			30 × 40	1.77
		35 × 30	1.96			35 × 30	1.74
	390	30 × 40	2.21		330	30 × 45	2.02
		35 × 35	2.20			35 × 35	1.99
	470	30 × 50	2.61		390	30 × 50	2.25
35 × 40		2.58	35 × 40	2.24			
560	35 × 45	3.07	470	35 × 45	2.54		
680	35 × 50	3.39	560	35 × 50	2.83		
420	100	25.4 × 25	0.92	500	56	25.4 × 25	0.66
	150	25.4 × 30	1.10		68	25.4 × 25	0.69
		30 × 25	1.20			82	25.4 × 30
	180	25.4 × 35	1.24		30 × 25		0.94
	220	25.4 × 40	1.43		100	25.4 × 35	1.00
		30 × 30	1.43		120	25.4 × 40	1.11
		35 × 25	1.44			30 × 30	1.12
	25.4 × 45	1.69	35 × 25			1.14	
	270	30 × 35	1.70		150	30 × 35	1.26
		35 × 30	1.74			180	25.4 × 50
	330	30 × 40	1.95		30 × 40		1.47
		30 × 45	2.18		35 × 30		1.50
	390	35 × 35	2.17		220	30 × 45	1.59
30 × 50		2.55	35 × 35	1.61			
470	35 × 45	2.54	270	35 × 40	1.73		
	35 × 50	2.83	330	35 × 50	1.89		

TLK Series

• 105°C 3,000Hrs assured.

- Non-solvent proof
- High Ripple, Wide Temp.
- For SMPS, Inverter.
- RoHS compliant.
- Halogen-free capacitors are also available.
- AEC-Q200 compliant : Please contact us for more details, test data, information.

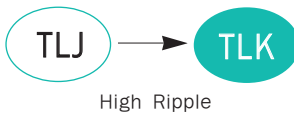

SPECIFICATIONS

Item	Characteristics	
Rated Voltage Range	400 ~ 500 V _{DC}	
Operating Temperature Range	-40 ~ +105°C	
Capacitance Tolerance	±20%(M) (at 20°C, 120Hz)	
Leakage Current	$I = 3\sqrt{CV}$ or 3mA, Whichever is smaller. Where, I:Leakage Current(µA), C:Nominal capacitance(µF), V:Rated voltage(V _{DC}) (at 20°C, 5minutes)	
*Dissipation Factor(Tanδ)	Rated voltage(V _{DC})	400 420~500
	Tanδ(Max.)	0.15 0.20
Temperature Characteristics (Max. Impedance ratio)	Rated voltage(V _{DC})	400 420~500
	Z(-25°C)/Z(20°C)	4 8
	Z(-40°C)/Z(20°C)	8 16
Load Life	The following specifications shall be satisfied when the capacitors are restored to 20°C after the rated voltage with the rated ripple current is applied (the peak voltage shall not exceed the rated voltage) for 3,000 hours at 105°C Capacitance change ≤ ±20% of the initial value Tanδ ≤ 200% of the initial specified value Leakage current ≤ The initial specified value	
Shelf Life	The following specifications shall be satisfied when the capacitors are restored to 20°C after the exposing them at 105°C for 1,000hours without voltage applied. The rated voltage shall be applied to the capacitors for a minimum of 30 minutes, at least 24 hours and not more than 48 hours before the measurements. Capacitance change ≤ ±20% of the initial value Tanδ ≤ 200% of the initial specified value Leakage current ≤ The initial specified value	
Others	Satisfied characteristics KS C IEC 60384-4	

*For capacitors with CV products > 100,000 higher Tanδ value may apply.
 When the capacitance exceeds 1,000µF, 0.01 shall be added every 1,000µF increase.

RATED RIPPLE CURRENT

When capacitor are operated in any other condition at 120HZ, the maximum ripple current must be multiplied by the figure shown in the table.

Frequency multiplying factor

V _{DC}	Freq.(Hz)	60	120	300	1k	10k~
400~500		0.77	1.00	1.16	1.30	1.41

DIMENSIONS OF TLK Series

Unit(mm)

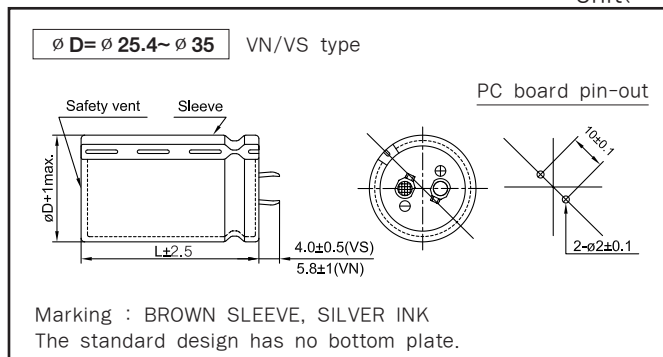

RATINGS OF TLK Series

V _{DC}	Capacitance (μF)	∅D×L(mm)	Rated Ripple Current (Arms/105°C,120Hz)	V _{DC}	Capacitance (μF)	∅D×L(mm)	Rated Ripple Current (Arms/105°C,120Hz)
400	120	25.4 × 25	1.16	450	100	25.4 × 25	1.01
	180	25.4 × 30	1.47		150	25.4 × 35	1.28
		30 × 25	1.51			30 × 25	1.32
	220	25.4 × 35	1.67		180	25.4 × 40	1.46
	270	25.4 × 40	1.90		220	25.4 × 45	1.63
		30 × 30	1.90			30 × 35	1.63
		35 × 25	1.91			35 × 25	1.61
	330	25.4 × 50	2.18		270	25.4 × 50	1.91
		30 × 35	2.16			30 × 40	1.89
		35 × 30	2.16			35 × 30	1.86
	390	30 × 40	2.43		330	30 × 45	2.26
		35 × 35	2.42			35 × 35	2.13
	470	30 × 50	2.87		390	30 × 50	2.42
35 × 40		2.83	35 × 40	2.41			
560	35 × 45	3.37	470	35 × 45	2.58		
680	35 × 50	3.73	560	35 × 50	2.85		
420	100	25.4 × 25	1.10	500	56	25.4 × 25	0.74
	150	25.4 × 30	1.32		68	25.4 × 25	0.78
		30 × 25	1.44			82	25.4 × 30
	180	25.4 × 35	1.48		30 × 25		1.05
	220	25.4 × 40	1.71		100	25.4 × 35	1.12
		30 × 30	1.71		120	25.4 × 40	1.24
		35 × 25	1.72			30 × 30	1.25
	25.4 × 45	2.01	35 × 25			1.27	
	270	30 × 35	2.01		150	30 × 35	1.51
		35 × 30	2.09			180	25.4 × 50
	330	30 × 40	2.34		30 × 40		1.64
		30 × 45	2.61		35 × 30		1.68
	390	35 × 35	2.60		220	30 × 45	1.78
30 × 50		3.06	35 × 35	1.80			
470	35 × 45	3.05	270	35 × 40	1.93		
	35 × 50	3.40	330	35 × 50	2.27		

TLR Series

• 105°C 3,000Hrs assured.

- Non-solvent proof
- High Ripple, Wide Temp.
- For SMPS, Inverter.
- RoHS compliant.
- Halogen-free capacitors are also available.

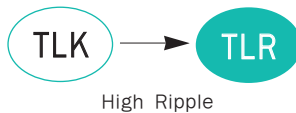

SPECIFICATIONS

Item	Characteristics		
Rated Voltage Range	400 ~ 500 V _{DC}		
Operating Temperature Range	-40 ~ +105°C		
Capacitance Tolerance	±20%(M) (at 20°C, 120Hz)		
Leakage Current	$I = 3\sqrt{CV}$ or 3mA, Whichever is smaller. Where, I:Leakage Current(µA), C:Nominal capacitance(µF), V:Rated voltage(V _{DC}) (at 20°C, 5minutes)		
*Dissipation Factor(Tanδ)	Rated voltage(V _{DC})	400	420~500
	Tanδ(Max.)	0.15	0.20
Temperature Characteristics (Max. Impedance ratio)	Rated voltage(V _{DC})	400	420~500
	Z(-25°C)/Z(20°C)	4	8
	Z(-40°C)/Z(20°C)	8	16
	(at 120Hz)		
Load Life	The following specifications shall be satisfied when the capacitors are restored to 20°C after the rated voltage with the rated ripple current is applied (the peak voltage shall not exceed the rated voltage) for 3,000 hours at 105°C Capacitance change ≤ ±20% of the initial value Tanδ ≤ 200% of the initial specified value Leakage current ≤ The initial specified value		
Shelf Life	The following specifications shall be satisfied when the capacitors are restored to 20°C after the exposing them at 105°C for 1,000hours without voltage applied. The rated voltage shall be applied to the capacitors for a minimum of 30 minutes, at least 24 hours and not more than 48 hours before the measurements. Capacitance change ≤ ±20% of the initial value Tanδ ≤ 200% of the initial specified value Leakage current ≤ The initial specified value		
Others	Satisfied characteristics KS C IEC 60384-4		

*For capacitors with CV products > 100,000 higher Tanδ value may apply.
 When the capacitance exceeds 1,000µF, 0.01 shall be added every 1,000µF increase.

RATED RIPPLE CURRENT

When capacitor are operated in any other condition at 120HZ, the maximum ripple current must be multiplied by the figure shown in the table.

Frequency multiplying factor

V _{DC}	Freq.(Hz)	60	120	300	1k	10k~
400~500		0.77	1.00	1.16	1.30	1.41

DIMENSIONS OF TLR Series

Unit(mm)

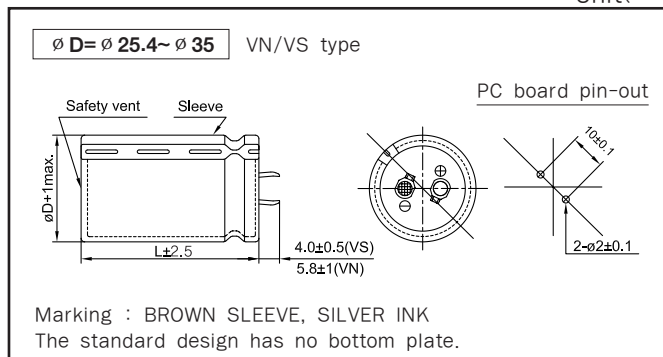

RATINGS OF TLR Series

V _{DC}	Capacitance (μF)	∅D×L(mm)	Rated Ripple Current (Arms/105°C, 120Hz)
400	150	25.4 × 25	1.19
	220	25.4 × 30	1.55
		30 × 25	1.57
	270	25.4 × 35	1.76
	330	30 × 30	2.00
		35 × 25	2.10
	390	25.4 × 50	2.28
		30 × 35	2.29
		35 × 30	2.29
	470	30 × 40	2.60
		35 × 35	2.57
	560	30 × 50	3.10
35 × 40		3.00	
680	35 × 45	3.60	
820	35 × 50	3.90	
420	120	25.4 × 25	1.18
	180	25.4 × 30	1.39
		30 × 25	1.50
	220	25.4 × 35	1.58
	270	25.4 × 40	1.80
		30 × 30	1.80
		35 × 25	1.81
	330	25.4 × 50	2.17
		30 × 35	2.17
	390	35 × 30	2.20
		30 × 40	2.49
	470	35 × 35	2.75
		30 × 50	3.06
	560	35 × 40	3.10
		35 × 45	3.20
680	35 × 50	3.68	

V _{DC}	Capacitance (μF)	∅D×L(mm)	Rated Ripple Current (Arms/105°C, 120Hz)
450	120	25.4 × 25	1.08
	150	25.4 × 30	1.20
	180	30 × 25	1.39
		25.4 × 35	1.30
	220	25.4 × 40	1.50
		30 × 30	1.50
	270	35 × 25	1.70
	330	25.4 × 50	1.97
		30 × 40	1.95
	390	30 × 45	2.39
		35 × 35	2.36
	470	30 × 50	2.55
		35 × 40	2.54
	560	35 × 45	2.68
680	35 × 50	2.95	
500	82	25.4 × 25	0.83
	120	25.4 × 30	1.02
		30 × 25	1.02
	150	25.4 × 40	1.20
		30 × 30	1.20
	220	35 × 30	1.52
		25.4 × 50	1.55
		30 × 40	1.55
	270	30 × 45	1.65
		35 × 35	1.70
	330	35 × 40	1.83
470	35 × 50	1.95	

TLC(LXG) Series

• 105°C 5,000Hrs assured.

- Non-solvent proof.
- Long Life.
- For SMPS, Inverter.
- RoHS compliant.
- Halogen-free capacitors are also available.
- AEC-Q200 compliant : Please contact us for more details, test data, information.



SPECIFICATIONS

Item	Characteristics																									
Rated Voltage Range	10 ~ 100 V _{dc}	200 ~ 500 V _{dc}																								
Operating Temperature Range	-40 ~ +105°C	-25 ~ +105°C																								
Capacitance Tolerance	±20%(M) (at 20°C, 120Hz)																									
Leakage Current	I = 0.02CV or 3mA, whichever is smaller. Where, I: Leakage current (µA) C: Nominal capacitance (µF) V: Rated voltage (V _{dc}) (at 20°C, 5 minutes)																									
※ Dissipation Factor(Tanδ)	<table border="1"> <thead> <tr> <th>Rated Voltage(V_{dc})</th> <th>10</th> <th>16</th> <th>25</th> <th>35</th> <th>50</th> <th>63~400</th> <th>420~500</th> </tr> </thead> <tbody> <tr> <td>Tanδ(Max.)</td> <td>0.60</td> <td>0.45</td> <td>0.30</td> <td>0.25</td> <td>0.20</td> <td>0.15</td> <td>0.20</td> </tr> </tbody> </table> <p>(at 20°C, 120Hz)</p>		Rated Voltage(V _{dc})	10	16	25	35	50	63~400	420~500	Tanδ(Max.)	0.60	0.45	0.30	0.25	0.20	0.15	0.20								
Rated Voltage(V _{dc})	10	16	25	35	50	63~400	420~500																			
Tanδ(Max.)	0.60	0.45	0.30	0.25	0.20	0.15	0.20																			
Temperature Characteristics (Max.Impedance ratio)	<table border="1"> <thead> <tr> <th>Rated Voltage(V_{dc})</th> <th>10~16</th> <th>25</th> <th>35</th> <th>50~63</th> <th>80~100</th> <th>200~400</th> <th>420~500</th> </tr> </thead> <tbody> <tr> <td>Z(-25°C)/Z(20°C)</td> <td>4</td> <td>3</td> <td>3</td> <td>2</td> <td>2</td> <td>4</td> <td>8</td> </tr> <tr> <td>Z(-40°C)/Z(20°C)</td> <td>15</td> <td>10</td> <td>8</td> <td>6</td> <td>5</td> <td>-</td> <td>-</td> </tr> </tbody> </table> <p>(at 120Hz)</p>		Rated Voltage(V _{dc})	10~16	25	35	50~63	80~100	200~400	420~500	Z(-25°C)/Z(20°C)	4	3	3	2	2	4	8	Z(-40°C)/Z(20°C)	15	10	8	6	5	-	-
Rated Voltage(V _{dc})	10~16	25	35	50~63	80~100	200~400	420~500																			
Z(-25°C)/Z(20°C)	4	3	3	2	2	4	8																			
Z(-40°C)/Z(20°C)	15	10	8	6	5	-	-																			
Load Life	<p>The following specifications shall be satisfied when the capacitors are restored to 20°C after the rated voltage with the rated ripple current is applied (the peak voltage shall not exceed the rated voltage) for 5,000 hours at 105°C.</p> <p>Capacitance change ≤ ±25% of the initial value Tanδ ≤ 250% of the initial specified value Leakage current ≤ The initial specified value</p>																									
Shelf Life	<p>The following specifications shall be satisfied when the capacitors are restored to 20°C after exposing them at 105°C for 1,000 hours without voltage applied. The rated voltage shall be applied to the capacitors for a minimum of 30 minutes, at least 24 hours and not more than 48 hours before the measurements.</p> <p>Capacitance change ≤ ±20% of the initial value Tanδ ≤ 150% of the initial specified value Leakage current ≤ The initial specified value</p>																									
Others	Satisfied characteristics KS C IEC 60384-4																									

※ For capacitors with CV products > 100,000 higher Tanδ value may apply.
 When the capacitance exceeds 1,000µF, 0.01 shall be added every 1,000µF increase.

RATED RIPPLE CURRENT

When capacitors are operated in any other conditions at 120Hz the maximum ripple current must be multiplied by the figure shown in the table.

Frequency multiplying factor

V _{dc}	Freq.(Hz)	60	120	300	1k	10k~
10~50V _{dc}		0.95	1.00	1.03	1.05	1.08
63~100V _{dc}		0.92	1.00	1.07	1.13	1.19
200~250V _{dc}		0.81	1.00	1.17	1.32	1.45
350~500V _{dc}		0.77	1.00	1.16	1.30	1.41

DIMENSIONS OF TLC(LXG) Series

Unit(mm)

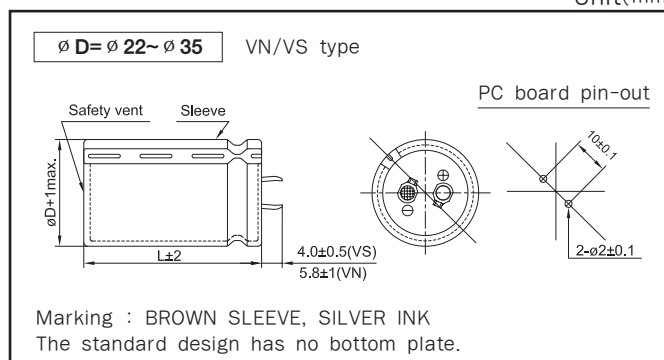

RATINGS OF TLC(LXG) Series

V _{DC} μF / ∅ D	10				16				25			
	22	25.4	30	35	22	25.4	30	35	22	25.4	30	35
3,900									22 × 25 1.31			
4,700									22 × 30 1.51	25.4 × 25 1.51		
5,600					22 × 25 1.44				22 × 35 1.70	25.4 × 30 1.69		
6,800	22 × 25 1.30				22 × 30 1.66	25.4 × 25 1.66			22 × 40 1.92	25.4 × 30 1.87	30 × 25 1.90	
8,200	22 × 30 1.49				22 × 35 1.87	25.4 × 30 1.87			22 × 45 2.05	25.4 × 35 2.14	30 × 30 2.15	35 × 25 2.19
10,000	22 × 30 1.65	25.4 × 25 1.64			22 × 40 2.12	25.4 × 30 2.07	30 × 25 2.11		22 × 50 2.45	25.4 × 40 2.43	30 × 30 2.31	35 × 25 2.35
12,000	22 × 35 1.85	25.4 × 30 1.85	30 × 25 1.89		22 × 45 2.32	25.4 × 35 2.37	30 × 30 2.37	35 × 25 2.42		25.4 × 50 2.78	30 × 35 2.70	35 × 30 2.76
15,000	22 × 40 2.12	25.4 × 35 2.16	30 × 25 2.06		22 × 50 2.74	25.4 × 40 2.71	30 × 30 2.58	35 × 25 2.63			30 × 40 3.13	35 × 35 3.16
18,000	22 × 50 2.45	25.4 × 40 2.43	30 × 30 2.37	35 × 25 2.42		25.4 × 50 3.11	30 × 35 3.02	35 × 30 3.09			30 × 50 3.64	35 × 40 3.61
22,000		25.4 × 45 2.62	30 × 35 2.73	35 × 30 2.79			30 × 40 3.46	35 × 35 3.49				35 × 45 4.00
27,000		25.4 × 50 3.11	30 × 40 3.13	35 × 30 3.00			30 × 50 4.07	35 × 40 4.04				35 × 50 4.70
33,000			30 × 45 3.34	35 × 35 3.49				35 × 45 4.29				
39,000			30 × 50 3.99	35 × 40 3.96				35 × 50 5.16				
47,000				35 × 50 4.62								

V _{DC} μF / ∅ D	35				50				63			
	22	25.4	30	35	22	25.4	30	35	22	25.4	30	35
1,000									22 × 25 1.00			
1,200									22 × 30 1.15	25.4 × 25 1.15		
1,500					22 × 25 1.02				22 × 35 1.32	25.4 × 25 1.28		
1,800					22 × 30 1.17	25.4 × 25 1.17			22 × 40 1.49	25.4 × 30 1.45	30 × 25 1.48	
2,200	22 × 25 1.10				22 × 35 1.33	25.4 × 30 1.32			22 × 45 1.63	25.4 × 35 1.67	30 × 30 1.68	35 × 25 1.71
2,700	22 × 25 1.21				22 × 40 1.51	25.4 × 30 1.47	30 × 25 1.50		22 × 50 1.92	25.4 × 40 1.90	30 × 35 1.93	35 × 25 1.83
3,300	22 × 30 1.42	25.4 × 25 1.41			22 × 45 1.68	25.4 × 35 1.70	30 × 30 1.70	35 × 25 1.74		25.4 × 50 2.20	30 × 35 2.07	35 × 30 2.18
3,900	22 × 35 1.58	25.4 × 30 1.58			22 × 50 1.91	25.4 × 40 1.89	30 × 30 1.84	35 × 25 1.89			30 × 40 2.41	35 × 35 2.43
4,700	22 × 40 1.78	25.4 × 30 1.70	30 × 25 1.77			25.4 × 45 2.05	30 × 35 2.11	35 × 30 2.16			30 × 50 2.80	35 × 40 2.78
5,600	22 × 45 1.96	25.4 × 35 1.98	30 × 30 1.98	35 × 25 2.03		25.4 × 50 2.38	30 × 40 2.39	35 × 35 2.41				35 × 45 3.04
6,800	22 × 50 2.26	25.4 × 40 2.24	30 × 30 2.14	35 × 25 2.20			30 × 50 2.79	35 × 40 2.78				35 × 50 3.55
8,200		25.4 × 50 2.57	30 × 35 2.50	35 × 30 2.55				35 × 45 3.06				
10,000			30 × 40 2.86	35 × 35 2.88				35 × 50 3.57				
12,000			30 × 50 3.32	35 × 40 3.30								
18,000				35 × 50 4.29	← Case Size ∅ D × L (mm) ← Rated Ripple Current (Arms/105°C, 120Hz)							

RATINGS OF TLC(LXG) Series

μF	Vdc ∅ D	80				100				200			
		22	25.4	30	35	22	25.4	30	35	22	25.4	30	35
180										22 × 25 0.79			
270										22 × 30 1.01	25.4 × 25 1.01		
330										22 × 35 1.15	25.4 × 30 1.15	30 × 25 1.18	
390					22 × 25 0.78					22 × 40 1.28	25.4 × 30 1.25	30 × 25 1.28	
470					22 × 25 0.85					22 × 50 1.46	25.4 × 35 1.44	30 × 30 1.44	35 × 25 1.53
560					22 × 30 0.99	25.4 × 25 0.98					25.4 × 40 1.60	30 × 35 1.63	35 × 25 1.66
680	22 × 25 0.97				22 × 35 1.12	25.4 × 25 1.08					25.4 × 50 1.85	30 × 40 1.86	35 × 30 1.84
820	22 × 30 1.12				22 × 40 1.26	25.4 × 30 1.23	30 × 25 1.25					30 × 45 2.04	35 × 35 2.06
1,000	22 × 35 1.27	25.4 × 25 1.23			22 × 45 1.39	25.4 × 35 1.41	30 × 30 1.42	35 × 25 1.45				30 × 50 2.39	35 × 40 2.38
1,200	22 × 40 1.42	25.4 × 30 1.39	30 × 25 1.41		22 × 50 1.60	25.4 × 40 1.59	30 × 35 1.61	35 × 25 1.58					35 × 50 2.76
1,500	22 × 45 1.60	25.4 × 35 1.62	30 × 25 1.57			25.4 × 50 1.86	30 × 40 1.87	35 × 30 1.85					
1,800	22 × 50 1.84	25.4 × 40 1.82	30 × 30 1.78	35 × 25 1.82			30 × 45 2.07	35 × 35 2.07					
2,200		25.4 × 50 2.11	30 × 35 2.05	35 × 30 2.09			30 × 50 2.40	35 × 40 2.39					
2,700			30 × 40 2.35	35 × 35 2.37				35 × 50 2.81					
3,300			30 × 50 2.75	35 × 40 2.73									
4,700				35 × 50 3.46									

μF	Vdc ∅ D	250				350				400			
		22	25.4	30	35	22	25.4	30	35	22	25.4	30	35
56										22 × 25 0.47			
68					22 × 25 0.49					22 × 30 0.57	25.4 × 25 0.53		
82					22 × 30 0.61					22 × 35 0.65	25.4 × 25 0.58		
100					22 × 35 0.65	25.4 × 25 0.64				22 × 35 0.71	25.4 × 30 0.71	30 × 25 0.71	
120					22 × 40 0.70	25.4 × 30 0.69	30 × 25 0.70			22 × 40 0.81	25.4 × 35 0.81	30 × 25 0.80	35 × 25 0.82
150	22 × 25 0.71				22 × 45 0.79	25.4 × 35 0.75	30 × 25 0.78	35 × 25 0.86		22 × 50 0.92	25.4 × 40 0.90	30 × 30 0.92	35 × 25 0.93
180	22 × 30 0.83	25.4 × 25 0.83			22 × 50 0.91	25.4 × 40 0.90	30 × 30 0.89	35 × 25 0.94			25.4 × 45 1.03	30 × 35 1.03	35 × 30 1.05
220	22 × 35 0.94	25.4 × 25 0.91				25.4 × 50 1.16	30 × 35 1.03	35 × 30 1.04			25.4 × 50 1.16	30 × 40 1.18	35 × 35 1.26
270	22 × 40 1.06	25.4 × 30 1.04	30 × 25 1.06				30 × 40 1.18	35 × 35 1.30				30 × 50 1.35	35 × 40 1.33
330	22 × 45 1.15	25.4 × 35 1.20	30 × 30 1.20	35 × 25 1.28			30 × 50 1.49	35 × 40 1.49					35 × 45 1.50
390	22 × 50 1.35	25.4 × 40 1.34	30 × 30 1.30	35 × 25 1.38				35 × 45 1.54					35 × 50 1.70
470		25.4 × 50 1.53	30 × 35 1.49	35 × 30 1.53				35 × 50 1.73					
560			30 × 40 1.69	35 × 35 1.70									
680			30 × 50 1.98	35 × 40 1.96									
1,000				35 × 50 2.53	← Case Size ∅D×L (mm) ← Rated Ripple Current (Arms/105°C, 120Hz)								

RATINGS OF TLC(LXG) Series

V _{DC} μF / ∅ D	420				450				500				
	22	25.4	30	35	22	25.4	30	35	22	25.4	30	35	
47					22 × 25 0.47					22 × 35 0.37			
56					22 × 30 0.53					22 × 35 0.44	25.4 × 30 0.41	30 × 30 0.45	
68	22 × 30 0.58				22 × 35 0.59	25.4 × 30 0.59				22 × 40 0.52	25.4 × 35 0.54	30 × 30 0.51	
82	22 × 30 0.65	25.4 × 30 0.66			22 × 35 0.66	25.4 × 30 0.66				22 × 45 0.62	25.4 × 35 0.62	30 × 35 0.58	
100	22 × 35 0.73	25.4 × 30 0.73			22 × 40 0.75	25.4 × 35 0.73	30 × 30 0.74				25.4 × 40 0.63	30 × 35 0.64	
120	22 × 40 0.83	25.4 × 35 0.83	30 × 30 0.83		22 × 45 0.84	25.4 × 35 0.83	30 × 30 0.83	35 × 30 0.84			25.4 × 45 0.71	30 × 40 0.71	35 × 30 0.72
150	22 × 45 0.95	25.4 × 40 0.95	30 × 30 0.95		22 × 50 0.95	25.4 × 40 0.95	30 × 35 0.95	35 × 30 0.96				30 × 45 0.76	35 × 30 0.80
180	22 × 50 1.07	25.4 × 40 1.07	30 × 35 1.07	35 × 30 1.08		25.4 × 45 1.07	30 × 35 1.07	35 × 30 1.08				30 × 50 0.89	35 × 40 0.90
220		25.4 × 50 1.21	30 × 40 1.21	35 × 30 1.22		25.4 × 50 1.21	30 × 40 1.21	35 × 35 1.22				30 × 60 1.05	35 × 45 1.01
270			30 × 45 1.38	35 × 35 1.41			30 × 45 1.38	35 × 40 1.41					35 × 50 1.44
330			30 × 50 1.60	35 × 40 1.60			30 × 50 1.60	35 × 45 1.61					35 × 60 1.55
390				35 × 45 1.80				35 × 50 1.80					
470				35 × 50 1.92									

← Case Size ∅ D × L (mm)
 ← Rated Ripple Current (Arms/105°C, 120Hz)

TLB Series

• 105°C 7,000Hrs assured.

- Non-solvent proof.
- Long Life.
- For SMPS, Inverter.
- RoHS compliant.
- Halogen-free capacitors are also available.
- AEC-Q200 compliant : Please contact us for more details, test data, information.



SPECIFICATIONS

Item	Characteristics						
Rated Voltage Range	160 ~ 500 V _{DC}						
Operating Temperature Range	-25 ~ +105°C						
Capacitance Tolerance	±20%(M) (at 20°C, 120Hz)						
Leakage Current	I = 0.02CV(µA) or 3mA, whichever is smaller. Where, I: Max. Leakage current(µA), C:Nominal capacitance(µF), V:Rated voltage(V _{DC}) (at 20°C, 5 minutes)						
※Dissipation Factor(Tanδ)	<table border="1"> <tr> <td>Rated voltage(V_{DC})</td> <td colspan="2">160 ~ 500</td> </tr> <tr> <td>Tanδ(Max.)</td> <td colspan="2">0.20</td> </tr> </table> (at 20°C, 120Hz)	Rated voltage(V _{DC})	160 ~ 500		Tanδ(Max.)	0.20	
Rated voltage(V _{DC})	160 ~ 500						
Tanδ(Max.)	0.20						
Temperature Characteristics (Max. Impedance ratio)	<table border="1"> <tr> <td>Rated voltage(V_{DC})</td> <td>160 ~ 400</td> <td>450 ~ 500</td> </tr> <tr> <td>Z(-25°C)/Z(20°C)</td> <td>4</td> <td>8</td> </tr> </table> (at 120Hz)	Rated voltage(V _{DC})	160 ~ 400	450 ~ 500	Z(-25°C)/Z(20°C)	4	8
Rated voltage(V _{DC})	160 ~ 400	450 ~ 500					
Z(-25°C)/Z(20°C)	4	8					
Load Life	The following specifications shall be satisfied when the capacitors are restored to 20°C after the rated voltage is applied for 7,000 hours at 105°C. Capacitance change ≤ ±25% of the initial value Tanδ ≤ 300% of the initial specified value Leakage current ≤ The initial specified value						
Shelf Life	The following specifications shall be satisfied when the capacitors are restored to 20°C after the exposing them at 105°C for 1,000 hours without voltage applied. The rated voltage shall be applied to the capacitors for a minimum of 30 minutes, at least 24 hours and not more than 48 hours before the measurements. Capacitance change ≤ ±20% of the initial value Tanδ ≤ 150% of the initial specified value Leakage current ≤ The initial specified value						
Others	Satisfied characteristics KS C IEC 60384-4						

※ For capacitors with CV products > 100,000 higher Tanδ value may apply.
When the capacitance exceeds 1,000µF, 0.01 shall be added every 1,000µF increase.

RATED RIPPLE CURRENT

When capacitors are operated in any other conditions at 120Hz the maximum ripple current must be multiplied by the figure shown in the table.

Frequency multiplying factor

V _{DC} \ Freq.(Hz)	60	120	300	1k	10k~
160~250V _{DC}	0.81	1.00	1.17	1.32	1.45
350~500V _{DC}	0.77	1.00	1.16	1.30	1.41

DIMENSIONS OF TLB Series

Unit(mm)

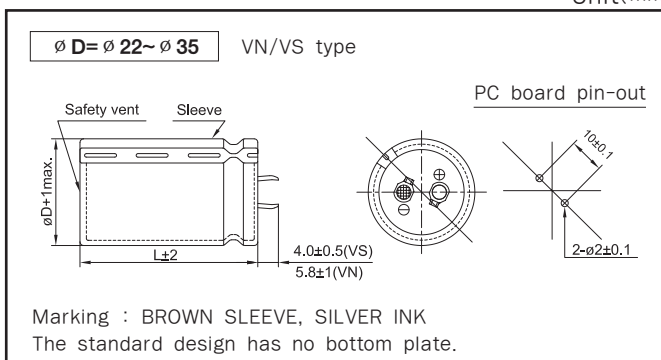

RATINGS OF TLB Series

Vbc μF / ∅ D	160				200				250			
	22	25.4	30	35	22	25.4	30	35	22	25.4	30	35
220					22 × 25 0.90				22 × 30 0.95			
270					22 × 30 1.05				22 × 35 1.08	25.4 × 25 1.05		
330	22 × 25 1.11				22 × 30 1.16	25.4 × 25 1.16			22 × 40 1.22	25.4 × 30 1.19		
390	22 × 30 1.26				22 × 35 1.29	25.4 × 30 1.29			22 × 45 1.36	25.4 × 35 1.35	30 × 25 1.32	
470	22 × 30 1.39	25.4 × 25 1.38			22 × 40 1.46	25.4 × 30 1.42	30 × 25 1.45		22 × 50 1.49	25.4 × 40 1.52	30 × 30 1.49	
560	22 × 35 1.55	25.4 × 30 1.55			22 × 45 1.63	25.4 × 35 1.62	30 × 30 1.62			25.4 × 45 1.70	30 × 35 1.69	
680	22 × 40 1.75	25.4 × 35 1.78	30 × 25 1.74			25.4 × 40 1.83	30 × 30 1.79			25.4 × 50 1.91	30 × 40 1.93	35 × 30 1.90
820	22 × 50 1.97	25.4 × 40 2.01	30 × 30 1.96			25.4 × 45 2.06	30 × 35 2.04				30 × 45 2.19	35 × 35 2.13
1,000		25.4 × 45 2.27	30 × 35 2.26				30 × 45 2.42	35 × 30 2.30				35 × 40 2.46
1,200		25.4 × 50 2.54	30 × 40 2.56	35 × 30 2.52			30 × 50 2.71	35 × 45 2.70				35 × 50 2.86
1,500			30 × 45 2.96	35 × 35 2.89				35 × 45 3.11				
1,800			30 × 50 3.32	35 × 40 3.30				35 × 50 3.50				
2,200				35 × 50 3.87								

Vbc μF / ∅ D	350				400				450			
	22	25.4	30	35	22	25.4	30	35	22	25.4	30	35
47									22 × 25 0.46			
56									22 × 30 0.52			
68					22 × 25 0.55				22 × 30 0.58	25.4 × 25 0.58		
82					22 × 30 0.63				22 × 35 0.65	25.4 × 30 0.65		
100	22 × 25 0.67				22 × 30 0.70	25.4 × 25 0.70			22 × 40 0.74	25.4 × 30 0.72	30 × 25 0.73	
120	22 × 30 0.77	25.4 × 25 0.76			22 × 35 0.79	25.4 × 30 0.79			22 × 45 0.83	25.4 × 35 0.82	30 × 30 0.82	
150	22 × 35 0.88	25.4 × 30 0.88			22 × 40 0.90	25.4 × 30 0.88	30 × 25 0.90			25.4 × 40 0.94	30 × 35 0.96	
180	22 × 40 0.99	25.4 × 30 0.96	30 × 25 0.98		22 × 45 0.99	25.4 × 35 1.01	30 × 30 1.01			25.4 × 45 1.06	30 × 35 1.05	35 × 30 1.07
220	22 × 45 1.12	25.4 × 35 1.11	30 × 30 1.11			25.4 × 40 1.14	30 × 35 1.16				30 × 40 1.20	35 × 35 1.21
270		25.4 × 40 1.26	30 × 35 1.28			25.4 × 50 1.32	30 × 40 1.33	35 × 30 1.31			30 × 50 1.41	35 × 40 1.40
330		25.4 × 45 1.40	30 × 35 1.42	35 × 30 1.45			30 × 45 1.52	35 × 35 1.48				35 × 45 1.60
390			30 × 40 1.60	35 × 35 1.61			30 × 50 1.69	35 × 40 1.68				35 × 50 1.79
470			30 × 50 1.86	35 × 40 1.85				35 × 45 1.91				
560				35 × 40 2.02				35 × 50 2.14				
680				35 × 50 2.36								

Case Size ∅D×L (mm)
 Rated Ripple Current (Arms/105°C, 120Hz)

RATINGS OF TLB Series

μF	V _{DC} ∅ D	500			
		22	25.4	30	35
56	22 × 35 0.33				
68	22 × 40 0.39	25.4 × 30 0.37			
82	22 × 45 0.45	25.4 × 35 0.44			
100	22 × 50 0.52	25.4 × 40 0.51	30 × 30 0.50		
120		25.4 × 45 0.59	30 × 35 0.58		
150		25.4 × 50 0.69	30 × 40 0.69	35 × 30 0.67	
180			30 × 45 0.80	35 × 35 0.79	
220			30 × 50 0.92	35 × 40 0.92	
270			30 × 60 1.11	35 × 50 1.12	
330		Case Size ∅ D × L (mm) →		35 × 60	
		Rated Ripple Current (Arms/105°C, 120Hz) →		1.34	

TLL Series

• 105°C 10,000Hrs assured.

- Non-solvent proof.
- Long Life.
- For SMPS, Inverter.
- RoHS compliant.
- Halogen-free capacitors are also available.

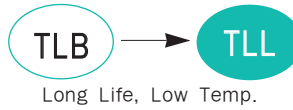

SPECIFICATIONS

Item	Characteristics		
Rated Voltage Range	200 ~ 500 V _{DC}		
Operating Temperature Range	-40 ~ +105°C		
Capacitance Tolerance	±20%(M) (at 20°C, 120Hz)		
Leakage Current	$I = 3\sqrt{CV}$ or 3mA, Whichever is smaller. Where, I: Leakage Current(µA), C: Nominal capacitance(µF), V: Rated voltage(V _{DC}) (at 20°C, 5minutes)		
*Dissipation Factor(Tanδ)	Rated voltage(V _{DC})	200 ~ 500	
	Tanδ(Max.)	0.20 (at 20°C, 120Hz)	
Temperature Characteristics (Max. Impedance ratio)	Rated voltage(V _{DC})	200~400	
	Z(-25°C)/Z(20°C)	4	
	Z(-40°C)/Z(20°C)	8	
		420~500	
		8	
		16	
			(at 120Hz)
Load Life	The following specifications shall be satisfied when the capacitors are restored to 20°C after the rated voltage is applied for 10,000 hours at 105°C. Capacitance change ≤ ±25% of the initial value Tanδ ≤ 300% of the initial specified value Leakage current ≤ The initial specified value		
Shelf Life	The following specifications shall be satisfied when the capacitors are restored to 20°C after the exposing them at 105°C for 1,000hours without voltage applied. The rated voltage shall be applied to the capacitors for a minimum of 30 minutes, at least 24 hours and not more than 48 hours before the measurements. Capacitance change ≤ ±20% of the initial value Tanδ ≤ 200% of the initial specified value Leakage current ≤ The initial specified value		
Others	Satisfied characteristics KS C IEC 60384-4		

※ For capacitors with CV products > 100,000 higher Tanδ value may apply.
 When the capacitance exceeds 1,000µF, 0.01 shall be added every 1,000µF increase.

RATED RIPPLE CURRENT

When capacitors are operated in any other conditions at 120Hz the maximum ripple current must be multiplied by the figure shown in the table.

Frequency multiplying factor

V _{DC}	Freq.(Hz)	60	120	300	1k	10k~
200~250V _{DC}		0.81	1.00	1.17	1.32	1.45
350~500V _{DC}		0.77	1.00	1.16	1.30	1.41

DIMENSIONS OF TLL Series

Unit(mm)

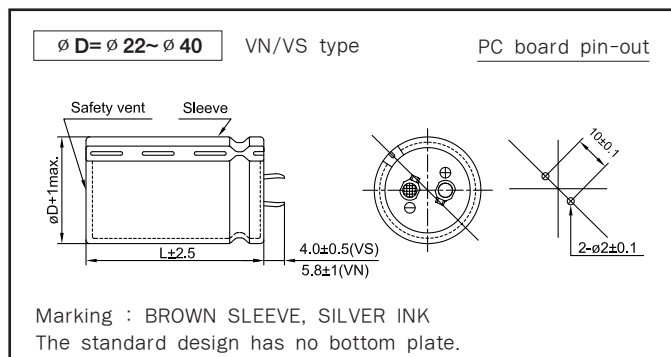

RATINGS OF TLL Series

V _{DC}	Capacitance (μF)	∅D×L(mm)	Rated Ripple Current (Arms/105°C,120Hz)
200	270	25.4 × 25	1.01
	390	25.4 × 30	1.24
	470	25.4 × 35	1.40
	560	25.4 × 40	1.55
		30 × 30	1.63
	680	25.4 × 50	1.87
		30 × 35	1.80
	820	30 × 40	2.01
		35 × 30	2.01
	1000	30 × 45	2.29
		35 × 35	2.29
		40 × 30	2.25
	1200	35 × 40	2.58
		40 × 35	2.51
1500	35 × 50	3.01	
1800	40 × 50	3.33	
250	330	25.4 × 30	1.15
	390	25.4 × 35	1.29
		30 × 30	1.32
	470	25.4 × 40	1.49
		30 × 35	1.51
	560	25.4 × 50	1.70
		35 × 30	1.69
	680	30 × 45	1.97
		35 × 35	1.92
	820	30 × 50	2.03
		35 × 40	2.01
		40 × 35	1.96
	1000	35 × 45	2.30
		40 × 40	2.55
1200	35 × 50	2.60	
1500	40 × 50	3.21	
400	100	25.4 × 25	0.63
	150	25.4 × 30	0.84
	180	25.4 × 35	0.97
	220	25.4 × 40	1.11
	270	25.4 × 50	1.25
		30 × 35	1.25
		35 × 30	1.26
	330	30 × 40	1.29
		35 × 35	1.46
	390	30 × 45	1.58
		40 × 30	1.53
	470	35 × 40	1.76
		40 × 35	1.76
	560	35 × 50	2.01
40 × 40		2.02	
680	40 × 50	2.29	
820	40 × 60	2.61	

V _{DC}	Capacitance (μF)	∅D×L(mm)	Rated Ripple Current (Arms/105°C,120Hz)
450	100	25.4 × 25	0.59
	120	25.4 × 30	0.68
	150	25.4 × 35	0.81
	180	25.4 × 40	0.93
		25.4 × 45	1.08
	220	30 × 40	1.20
		35 × 30	1.17
	270	30 × 45	1.21
		35 × 35	1.19
		30 × 50	1.40
	330	30 × 50	1.40
	390	35 × 40	1.52
470	35 × 50	1.79	
560	40 × 60	2.19	
500	68	25.4 × 30	0.33
	82	25.4 × 35	0.37
	100	30 × 30	0.41
		25.4 × 45	0.47
	120	30 × 35	0.47
		30 × 40	0.54
	150	35 × 30	0.55
		30 × 45	0.61
	180	35 × 35	0.62
		35 × 40	0.71
220	35 × 40	0.71	
270	35 × 50	0.83	

UDA Series

• 125°C 1,000Hrs assured.

- Non-solvent proof.
- Wide Temperature range.
- For automotive and industrial machine.
- RoHS compliant.
- Halogen-free capacitors are also available.

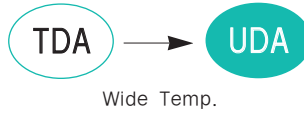

SPECIFICATIONS

Item	Characteristics																			
Rated Voltage Range	16 ~ 80 V _{dc}	160 ~ 250 V _{dc}																		
Operating Temperature Range	-40 ~ +125°C	-25 ~ +125°C																		
Capacitance Tolerance	±20% (M) (at 20°C, 120Hz)																			
Leakage Current	I = 0.02CV or 3mA, whichever is smaller. Where, I: Leakage current(µA) C: Nominal capacitance(µF) V: Rated voltage(V _{dc}) (at 20°C, 5 minutes)																			
※ Dissipation Factor(Tanδ)	<table border="1"> <thead> <tr> <th>Rated Voltage(V_{dc})</th> <th>16</th> <th>25</th> <th>35</th> <th>50~80</th> <th>160~250</th> </tr> </thead> <tbody> <tr> <td>Tanδ(Max.)</td> <td>0.45</td> <td>0.40</td> <td>0.35</td> <td>0.30</td> <td>0.20</td> </tr> </tbody> </table> (at 20°C, 120Hz)		Rated Voltage(V _{dc})	16	25	35	50~80	160~250	Tanδ(Max.)	0.45	0.40	0.35	0.30	0.20						
Rated Voltage(V _{dc})	16	25	35	50~80	160~250															
Tanδ(Max.)	0.45	0.40	0.35	0.30	0.20															
Temperature Characteristics (Max.Impedance ratio)	<table border="1"> <thead> <tr> <th>Rated Voltage(V_{dc})</th> <th>16</th> <th>25</th> <th>35</th> <th>50~80</th> <th>160~250</th> </tr> </thead> <tbody> <tr> <td>Z(-25°C)/Z(20°C)</td> <td>4</td> <td>3</td> <td>3</td> <td>2</td> <td>4</td> </tr> <tr> <td>Z(-40°C)/Z(20°C)</td> <td>15</td> <td>10</td> <td>8</td> <td>6</td> <td>-</td> </tr> </tbody> </table> (120Hz)		Rated Voltage(V _{dc})	16	25	35	50~80	160~250	Z(-25°C)/Z(20°C)	4	3	3	2	4	Z(-40°C)/Z(20°C)	15	10	8	6	-
Rated Voltage(V _{dc})	16	25	35	50~80	160~250															
Z(-25°C)/Z(20°C)	4	3	3	2	4															
Z(-40°C)/Z(20°C)	15	10	8	6	-															
Load Life	<p>The following specifications shall be satisfied when the capacitors are restored to 20°C after the rated voltage is applied for 1,000 hours at 125°C.</p> <p>Capacitance change ≤ ±20% of the initial value Tanδ ≤ 200% of the initial specified value Leakage Current ≤ The initial specified value</p>																			
Shelf Life	<p>The following specifications shall be satisfied when the capacitors are restored to 20°C after the exposing them at 125°C for 500 hours without voltage applied. The rated voltage shall be applied to the capacitors for a minimum of 30 minutes, at least 24 hours and not more than 48 hours before the measurement.</p> <p>Capacitance change ≤ ±20% of the initial value Tanδ ≤ 200% of the initial specified value Leakage Current ≤ The initial specified value</p>																			
Others	Satisfied characteristics KS C IEC 60384-4																			

※ For capacitors with CV products > 100,000 Higher Tanδ value may apply.
 When the capacitance exceeds 1,000µF, 0.01 shall be added every 1,000µF increase.

RATED RIPPLE CURRENT

When capacitors are operated in any other condition at 120Hz, the maximum ripple current must be multiplied by the figure shown in the table.

Frequency multiplying factor

V _{dc}	Freq.(Hz)	60	120	300	1k	10k~
16~50V _{dc}		0.95	1.00	1.03	1.05	1.08
63~100V _{dc}		0.92	1.00	1.07	1.13	1.19
160~250V _{dc}		0.81	1.00	1.17	1.32	1.45

DIMENSIONS OF UDA Series

Unit(mm)

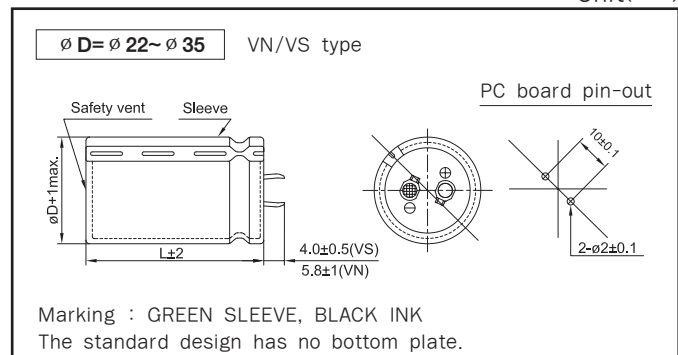

RATINGS OF UDA Series

μF \ V _{DC} \ ϕ D	16				25				35			
	22	25.4	30	35	22	25.4	30	35	22	25.4	30	35
1,000									22 × 30 0.85			
1,500					22 × 30 0.95				22 × 40 1.16	25.4 × 30 1.14		
2,200	22 × 30 1.00				22 × 40 1.28	25.4 × 30 1.41			22 × 50 1.54	25.4 × 40 1.54	30 × 30 1.50	
3,300	22 × 40 1.36	25.4 × 35 1.41			22 × 50 1.72	25.4 × 40 1.72	30 × 30 1.68				30 × 40 2.04	35 × 30 2.09
4,700	22 × 50 1.78	25.4 × 40 1.77	30 × 30 1.74			25.4 × 50 2.23	30 × 40 2.22	35 × 30 2.17				35 × 40 2.61
6,800			30 × 40 2.31	35 × 30 2.26			30 × 50 2.90	35 × 40 2.87				
10,000				35 × 45 3.14								

μF \ V _{DC} \ ϕ D	50				63				80			
	22	25.4	30	35	22	25.4	30	35	22	25.4	30	35
330					22 × 35 0.69	25.4 × 30 0.71			22 × 30 0.59			
470					22 × 40 0.87	25.4 × 35 0.91	30 × 30 0.93		22 × 40 0.79	25.4 × 35 0.82		
680	22 × 30 0.78					25.4 × 45 1.21	30 × 35 1.19	35 × 30 1.22		25.4 × 40 1.04	30 × 35 1.07	
1,000	22 × 40 1.06	25.4 × 30 1.04					30 × 45 1.60	35 × 40 1.65			30 × 45 1.42	35 × 35 1.40
1,500	22 × 50 1.42	25.4 × 40 1.42	30 × 30 1.39					35 × 50 2.16				35 × 45 1.86
2,200			30 × 40 1.86	35 × 35 1.91								
3,300				35 × 40 2.45								

μF \ V _{DC} \ ϕ D	160				200				250			
	22	25.4	30	35	22	25.4	30	35	22	25.4	30	35
100									22 × 30 0.32			
150	22 × 30 0.37				22 × 35 0.42				22 × 40 0.44	25.4 × 30 0.43		
220	22 × 40 0.50	25.4 × 30 0.49			22 × 45 0.56	25.4 × 40 0.58	30 × 30 0.57		22 × 50 0.58	25.4 × 40 0.58	30 × 35 0.60	35 × 30 0.61
330	22 × 50 0.67	25.4 × 40 0.67	30 × 30 0.65			25.4 × 50 0.77	30 × 40 0.77	35 × 30 0.75			30 × 45 0.80	35 × 35 0.79
470		25.4 × 50 0.87	30 × 40 0.86	35 × 30 0.84				35 × 40 0.98				35 × 45 1.03
680			30 × 50 1.12	35 × 40 1.11				35 × 50 1.28				35 × 50 1.28
1,000				35 × 50 1.46	← Case Size ϕ D × L (mm)							
					← Rated Ripple Current (Arms/125°C, 120Hz)							

RVA Series

• 85°C 2,000Hrs assured.

- Non-solvent proof.
- No sparks with DC overvoltage.
- For SMPS.(SET is specified Safety Standard)
- RoHS compliant.
- Halogen-free capacitors are also available.

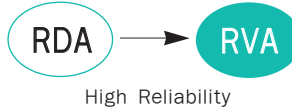

SPECIFICATIONS

Item	Characteristics						
Rated Voltage Range	200 ~ 450 V _{DC}						
Operating Temperature Range	-25 ~ +85°C						
Capacitance Tolerance	±20%(M) (at 20°C, 120Hz)						
Leakage Current	I=0.02CV or 3mA, whichever is smaller. Where, I:Leakage Current(µA), C:Nominal capacitance(µF), V:Rated voltage(V _{DC}) (at 20°C, 5 minutes)						
*Dissipation Factor(Tanδ)	<table border="1"> <tr> <td>Rated voltage(V_{DC})</td> <td>200~400</td> <td>450</td> </tr> <tr> <td>Tanδ(Max.)</td> <td>0.15</td> <td>0.20</td> </tr> </table> (at 20°C, 120Hz)	Rated voltage(V _{DC})	200~400	450	Tanδ(Max.)	0.15	0.20
Rated voltage(V _{DC})	200~400	450					
Tanδ(Max.)	0.15	0.20					
Temperature Characteristics (Max. Impedance ratio)	<table border="1"> <tr> <td>Rated voltage(V_{DC})</td> <td>200~400</td> <td>450</td> </tr> <tr> <td>Z(-25°C)/Z(20°C)</td> <td>4</td> <td>8</td> </tr> </table> (at 120Hz)	Rated voltage(V _{DC})	200~400	450	Z(-25°C)/Z(20°C)	4	8
Rated voltage(V _{DC})	200~400	450					
Z(-25°C)/Z(20°C)	4	8					
DC Over Voltage Test	When an excessive DC voltage is applied to the capacitors under the test conditions on next page, the voltage shall operate and than the capacitors shall come to open-circuit without flaming materials.						
Load Life	The following specifications shall be satisfied when the capacitors are restored to 20°C after the rated voltage is applied for 2,000 hours at 85°C. Capacitance change ≤ ±20% of the initial value Tan δ ≤ ±200% of the initial specified value Leakage current ≤ The initial specified value						
Shelf Life	The following specifications shall be satisfied when the capacitors are restored to 20°C after the exposing them at 85°C for 1,000 hours without voltage applied. The rated voltage shall be applied to the capacitors for a minimum of 30 minutes, at least 24 hours and not more than 48 hours before the measurements. Capacitance change ≤ ±20% of the initial value Tan δ ≤ ±200% of the initial specified value Leakage current ≤ The initial specified value						
Others	Satisfied characteristics KS C IEC 60384-4						

* For capacitors with CV products > 100,000 higher Tanδ value may apply.
 When the capacitance exceeds 1,000µF, 0.01 shall be added every 1,000µF increase.

RATED RIPPLE CURRENT

When capacitor are operated in any other condition at 120Hz, the maximum ripple current must be multiplied by the figure shown in the table.

Frequency multiplying factor

V _{DC} \ Freq.(Hz)	60	120	300	1k	10k~
200~250V _{DC}	0.81	1.00	1.17	1.32	1.45
350~450V _{DC}	0.77	1.00	1.16	1.30	1.41

DIMENSIONS OF RVA Series

Unit(mm)

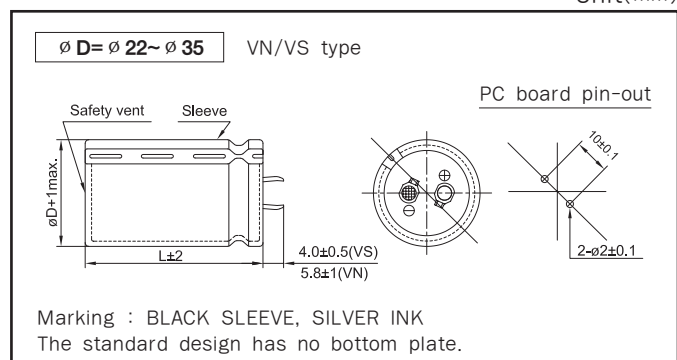

RATINGS OF RVA Series

V _{DC} μF ∅ D	200				250			
	22	25.4	30	35	22	25.4	30	35
120					22 × 20 0.80			
150	22 × 20 0.88				22 × 25 0.95	25.4 × 20 0.98		
180	22 × 25 1.05				22 × 25 1.12	25.4 × 20 1.13		
220	22 × 25 1.18	25.4 × 20 1.20			22 × 30 1.15	25.4 × 25 1.18	30 × 20 1.20	
270	22 × 30 1.27	25.4 × 25 1.24	30 × 20 1.26		22 × 35 1.31	25.4 × 30 1.32	30 × 20 1.28	
330	22 × 30 1.45	25.4 × 25 1.42	30 × 20 1.44		22 × 40 1.49	25.4 × 30 1.51	30 × 25 1.48	35 × 20 1.51
390	22 × 35 1.59	25.4 × 30 1.58	30 × 20 1.58	35 × 20 1.26	22 × 45 1.67	25.4 × 35 1.63	30 × 30 1.66	35 × 25 1.67
470	22 × 40 1.78	25.4 × 30 1.80	30 × 25 1.80	35 × 20 1.80	22 × 50 1.88	25.4 × 40 1.86	30 × 30 1.89	35 × 25 1.89
560	22 × 45 2.00	25.4 × 35 1.97	30 × 25 2.01	35 × 25 2.03		25.4 × 45 2.09	30 × 35 2.14	35 × 30 2.09
680	22 × 50 2.27	25.4 × 40 2.24	30 × 30 2.28	35 × 25 2.28		25.4 × 50 2.44	30 × 40 2.43	35 × 30 2.46
820		25.4 × 40 2.53	30 × 35 2.59	35 × 30 2.60			30 × 45 2.75	35 × 35 2.77
1,000		25.4 × 45 2.88	30 × 40 2.95	35 × 30 2.90			30 × 50 3.31	35 × 40 3.22
1,200			30 × 45 3.34	35 × 35 3.31				35 × 45 3.42
1,500			30 × 50 3.84	35 × 40 3.82				35 × 50 4.06
1,800				35 × 45 4.33				
2,200				35 × 50 4.92				

V _{DC} μF ∅ D	400				450			
	22	25.4	30	35	22	25.4	30	35
47	22 × 20 0.36							
56	22 × 20 0.40							
68	22 × 25 0.46	25.4 × 20 0.48				22 × 30 0.64		
82	22 × 30 0.71	25.4 × 20 0.72				22 × 30 0.70		
100	22 × 30 0.78	25.4 × 25 0.78	30 × 20 0.79		22 × 35 0.80	25.4 × 30 0.80		
120	22 × 35 0.88	25.4 × 30 0.87	30 × 25 0.90		22 × 40 0.91	25.4 × 30 0.91	30 × 25 0.92	
150	22 × 40 1.02	25.4 × 30 1.02	30 × 25 1.03	35 × 20 1.03	22 × 45 1.04	25.4 × 35 1.05	30 × 30 1.03	
180	22 × 45 1.14	25.4 × 35 1.11	30 × 30 1.13	35 × 25 1.14	22 × 50 1.18	25.4 × 40 1.15	30 × 30 1.17	35 × 25 1.20
220	22 × 50 1.29	25.4 × 40 1.27	30 × 30 1.30	35 × 25 1.27		25.4 × 45 1.31	30 × 35 1.36	35 × 30 1.35
270		25.4 × 45 1.45	30 × 35 1.48	35 × 30 1.49		25.4 × 50 1.55	30 × 40 1.60	35 × 35 1.59
330		25.4 × 50 1.65	30 × 40 1.65	35 × 30 1.67			30 × 45 1.90	35 × 40 1.88
390			30 × 45 1.85	35 × 35 1.88			30 × 50 2.09	35 × 45 2.08
470			30 × 50 2.09	35 × 40 2.07				35 × 50 2.40
560				35 × 45 2.34				
680				35 × 50 2.74				

← Case Size ∅ D × L (mm)
← Rated Ripple Current (Arms/85°C, 120Hz)

DC OVERVOLTAGE TEST CONDITIONS

The safety vent will operate and the capacitor shall become an open circuit without burning materials when the following excess DC voltage is applied.

● Test DC voltage

Rated voltage	Nominal capacitance	Current Limit	Test voltage
200V _{DC}	< 330 μF	4A	300/375V _{DC}
	330 μF ≤ C < 470 μF	5A	
	≥ 470 μF	7A	
250V _{DC}	< 100 μF	4A	350/450V _{DC}
	100 μF ≤ C < 220 μF	5A	
	≥ 220 μF	7A	
400V _{DC}	< 100 μF	4A	500/600V _{DC}
	100 μF ≤ C < 220 μF	5A	
	≥ 220 μF	7A	
450V _{DC}	< 100 μF	4A	550/675V _{DC}
	100 μF ≤ C < 220 μF	5A	
	≥ 220 μF	7A	

● Test circuit

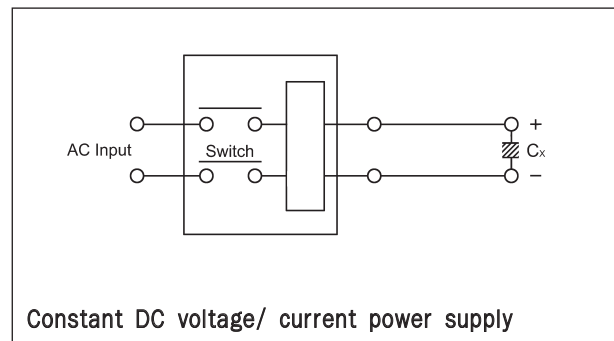

RATINGS OF TVA Series

V _{DC} μF / ∅ D	200				250			
	22	25.4	30	35	22	25.4	30	35
120					22 × 20 0.68			
150					22 × 25 0.77			
180	22 × 25 0.82				22 × 30 0.87	25.4 × 25 0.93		
220	22 × 25 0.92				22 × 30 1.00	25.4 × 25 1.02		
270	22 × 30 1.02				22 × 35 1.14	25.4 × 30 1.13	30 × 25 1.25	
330	22 × 35 1.20	25.4 × 25 1.20			22 × 40 1.28	25.4 × 30 1.29	30 × 25 1.38	
390	22 × 40 1.35	25.4 × 30 1.35			22 × 45 1.42	25.4 × 35 1.46	30 × 30 1.52	35 × 25 1.62
470	22 × 45 1.52	25.4 × 30 1.45	30 × 25 1.47			25.4 × 40 1.64	30 × 30 1.67	35 × 25 1.81
560	22 × 50 1.74	25.4 × 35 1.60	30 × 30 1.60			25.4 × 45 1.82	30 × 35 1.87	35 × 30 1.99
680		25.4 × 40 1.82	30 × 30 1.81	35 × 25 1.86		25.4 × 50 1.96	30 × 40 2.12	35 × 30 2.19
820		25.4 × 50 2.11	30 × 35 2.11	35 × 30 2.11			30 × 45 2.39	35 × 35 2.42
1,000			30 × 40 2.40	35 × 30 2.40			30 × 50 2.52	35 × 40 2.57
1,200			30 × 50 2.65	35 × 35 2.65				35 × 45 2.70
1,500				35 × 45 3.08				35 × 50 3.00
1,800				35 × 50 3.31				

V _{DC} μF / ∅ D	400				450				
	22	25.4	30	35	22	25.4	30	35	
56	22 × 25 0.45								
68	22 × 30 0.51					22 × 30 0.53			
82	22 × 30 0.58					22 × 35 0.64			
100	22 × 35 0.66	25.4 × 25 0.66				22 × 40 0.69	25.4 × 30 0.69		
120	22 × 40 0.76	25.4 × 30 0.76				22 × 45 0.80	25.4 × 35 0.80		
150	22 × 45 0.85	25.4 × 35 0.85	30 × 30 0.85			22 × 50 0.88	25.4 × 40 0.88	30 × 30 0.88	
180	22 × 50 0.94	25.4 × 40 0.95	30 × 30 0.95				25.4 × 45 1.00	30 × 35 1.00	
220		25.4 × 45 1.24	30 × 35 1.24	35 × 30 1.24			25.4 × 50 1.12	30 × 40 1.12	35 × 30 1.12
270		25.4 × 50 1.30	30 × 40 1.30	35 × 30 1.30				30 × 45 1.28	35 × 35 1.28
330			30 × 45 1.47	35 × 35 1.47				30 × 50 1.45	35 × 40 1.45
390									35 × 45 1.55
470									35 × 50 1.85
560									

← Case Size ∅ D × L (mm)
← Rated Ripple Current (Arms/105°C, 120Hz)

DC OVERVOLTAGE TEST CONDITIONS

The safety vent will operate and the capacitor shall become an open circuit without burning materials when the following excess DC voltage is applied.

● Test DC voltage

Rated voltage	Nominal capacitance	Current Limit	Test voltage
200V _{DC}	< 330 μF	4A	300/375V _{DC}
	330 μF ≤ C < 470 μF	5A	
	≥ 470 μF	7A	
250V _{DC}	< 100 μF	4A	350/450V _{DC}
	100 μF ≤ C < 220 μF	5A	
	≥ 220 μF	7A	
400V _{DC}	< 100 μF	4A	500/600V _{DC}
	100 μF ≤ C < 220 μF	5A	
	≥ 220 μF	7A	
450V _{DC}	< 100 μF	4A	550/675V _{DC}
	100 μF ≤ C < 220 μF	5A	
	≥ 220 μF	7A	

● Test circuit

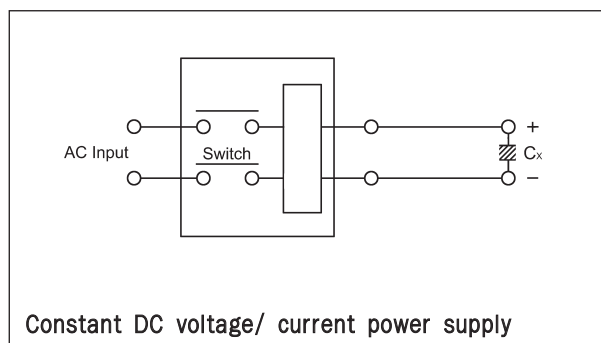

DL Series

• 85°C 2,000Hrs assured.

- Non-solvent proof.
- For AMP, AVR.
- General Audio grade.
- RoHS compliant.
- Halogen-free capacitors are also available.



SPECIFICATIONS

Item	Characteristics				
Rated Voltage Range	50 ~ 100 V _{DC}				
Operating Temperature Range	-40 ~ +85°C				
Capacitance Tolerance	±20%(M) (at 20°C, 120Hz)				
Leakage Current	I = 0.01CV or 2mA, whichever is smaller. Where, I: Leakage current (µA) C: Nominal capacitance (µF) V: Rated voltage (V _{DC}) (at 20°C, 5 minutes)				
Dissipation Factor(Tanδ)	Refer to the below table. (at 20°C, 120Hz)				
Temperature Characteristics (Max. Impedance ratio)	<table border="1" style="margin-left: auto; margin-right: auto;"> <tr> <td>Z(-25°C)/Z(20°C)</td> <td>4</td> </tr> <tr> <td>Z(-40°C)/Z(20°C)</td> <td>15</td> </tr> </table> (at 120Hz)	Z(-25°C)/Z(20°C)	4	Z(-40°C)/Z(20°C)	15
Z(-25°C)/Z(20°C)	4				
Z(-40°C)/Z(20°C)	15				
Load Life	The following specifications shall be satisfied when the capacitors are restored to 20°C after the rated voltage applied for 2,000 hours at 85°C. Capacitance change ≤ ±20% of the initial value. Tanδ ≤ 200% of the initial specified value. Leakage current ≤ The initial specified value				
Shelf Life	The following specifications shall be satisfied when the capacitors are restored to 20°C after the exposing them at 85°C for 1,000 hours without voltage applied. The rated voltage shall be applied to the capacitors for a minimum of 30 minutes, at least 24 hours and not more than 48 hours before the measurements. Capacitance change ≤ ±20% of the initial value. Tanδ ≤ 200% of the initial specified value. Leakage current ≤ The initial specified value.				
Charge & Discharge	5,000 times (at 70°C) After this test is completed, the capacitors shall be satisfied the following specifications Capacitance change ≤ ±20% of the initial value. Tanδ ≤ 150% of the initial specified value. Leakage current ≤ The initial specified value. where, Charge resistance : 2.2 Ω Charge conditions: rated volt. 1(A) Discharge resistance: 100 Ω Charge and discharge time:30 sec(each)				
Others	Satisfied characteristics KS C IEC 60384-4				

RATINGS OF DL Series

µF	V _{DC}	50			63			80			100		
		Case Size	Tanδ(Max.)	Rated Ripple Current (Arms/85°C, 120Hz)	Case Size	Tanδ(Max.)	Rated Ripple Current (Arms/85°C, 120Hz)	Case Size	Tanδ(Max.)	Rated Ripple Current (Arms/85°C, 120Hz)	Case Size	Tanδ(Max.)	Rated Ripple Current (Arms/85°C, 120Hz)
3,300	50	25.4 × 30	0.20	1.81	25.4 × 40	0.20	1.96	25.4 × 50	0.20	1.07	30 × 60	0.20	2.32
		30 × 25	0.20	1.86	30 × 30	0.25	1.75	30 × 40	0.20	1.08	35 × 50	0.20	2.32
								35 × 35	0.25	1.86	40 × 40	0.25	2.28
4,700	50	25.4 × 40	0.25	2.09	25.4 × 50	0.25	2.21	25.4 × 60	0.25	2.33	35 × 60	0.25	2.62
		30 × 30	0.25	2.09	30 × 40	0.25	2.22	30 × 50	0.25	2.35	40 × 50	0.25	2.61
					35 × 30	0.30	2.03	35 × 40	0.30	2.73			
6,800	50	25.4 × 50	0.25	2.65	30 × 50	0.30	2.58	30 × 60	0.30	2.72	40 × 60	0.25	3.29
		30 × 40	0.25	2.67	35 × 40	0.30	2.57	35 × 50	0.30	2.72			
		35 × 35	0.25	2.67				40 × 40	0.30	2.72			
8,200	50	30 × 50	0.35	2.63	30 × 60	0.35	2.77	35 × 60	0.30	3.16			
		35 × 40	0.35	2.61	35 × 50	0.35	2.77	40 × 50	0.30	3.15			
					40 × 40	0.35	2.77						
10,000	50	30 × 50	0.35	2.90	35 × 60	0.35	3.23	40 × 60	0.35	3.37			
		35 × 40	0.35	2.88	40 × 50	0.35	3.22						
12,000	50	30 × 60	0.35	3.32	35 × 60	0.40	3.31	50 × 50	0.40	3.50			
		35 × 50	0.35	3.34	40 × 50	0.40	3.30						
		40 × 40	0.35	3.35									
15,000	50	35 × 60	0.35	3.85	40 × 60	0.40	3.86						
		40 × 50	0.35	3.92									
22,000	50	40 × 60	0.35	5.00									

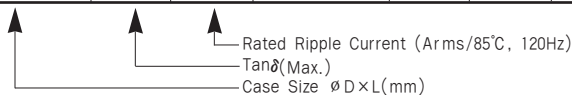

DIMENSIONS : Refer to next page.

AHS Series

• 85°C 2,000Hrs assured.

- Non-solvent proof.
- Hi-Fi Audio grade.
- For Audio, AMP, AVR.
- RoHS compliant.
- Halogen-free capacitors are also available.

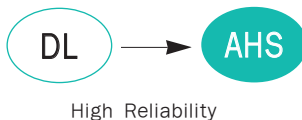

SPECIFICATIONS

Item	Characteristics				
Rated Voltage Range	50 ~ 100 V _{DC}				
Operating Temperature Range	-40 ~ +85°C				
Capacitance Tolerance	±20%(M) (at 20°C, 120Hz)				
Leakage Current	I = 0.01CV or 2mA, whichever is smaller. Where, I: Leakage current (µA) C: Nominal capacitance (µF) V: Rated voltage (V _{DC}) (at 20°C, 5 minutes)				
Dissipation Factor(Tanδ)	Tanδ shall not exceed the value shown in the table of RATINGS. (at 20°C, 120Hz)				
Temperature Characteristics (Max.Impedance ratio)	<table border="1" style="margin-left: auto; margin-right: auto;"> <tr> <td>Z(-25°C)/Z(20°C)</td> <td>4</td> </tr> <tr> <td>Z(-40°C)/Z(20°C)</td> <td>15</td> </tr> </table> (at 120Hz)	Z(-25°C)/Z(20°C)	4	Z(-40°C)/Z(20°C)	15
Z(-25°C)/Z(20°C)	4				
Z(-40°C)/Z(20°C)	15				
Load Life	The following specifications shall be satisfied when the capacitors are restored to 20°C after the rated voltage applied for 2,000 hours at 85°C. Capacitance change ≤ ±20% of the initial value. Tanδ ≤ 200% of the initial specified value. Leakage current ≤ The initial specified value				
Shelf Life	The following specifications shall be satisfied when the capacitors are restored to 20°C after exposing them at 85°C for 1,000 hours without voltage applied. The rated voltage shall be applied to the capacitors for a minimum of 30 minutes, at least 24 hours and not more than 48 hours before the measurements. Capacitance change ≤ ±20% of the initial value. Tanδ ≤ 200% of the initial specified value. Leakage current ≤ The initial specified value				
Charge & Discharge	5,000 times (at 70°C) After this test is completed, the capacitors shall be satisfied the following specifications. Capacitance change ≤ ±20% of the initial value. Tan δ ≤ 150% of the initial specified value. Leakage current ≤ The initial specified value No visible damage and no leakage electrolyte where, Charge resistance: 2.2 Ω Charge conditions: rated volt. 1(A) Discharge resistance: 100 Ω Charge and discharge time: 30 sec(each)				
Others	Satisfied characteristics KS C IEC 60384-4				

DIMENSIONS OF AHS/DL Series

Unit(mm)

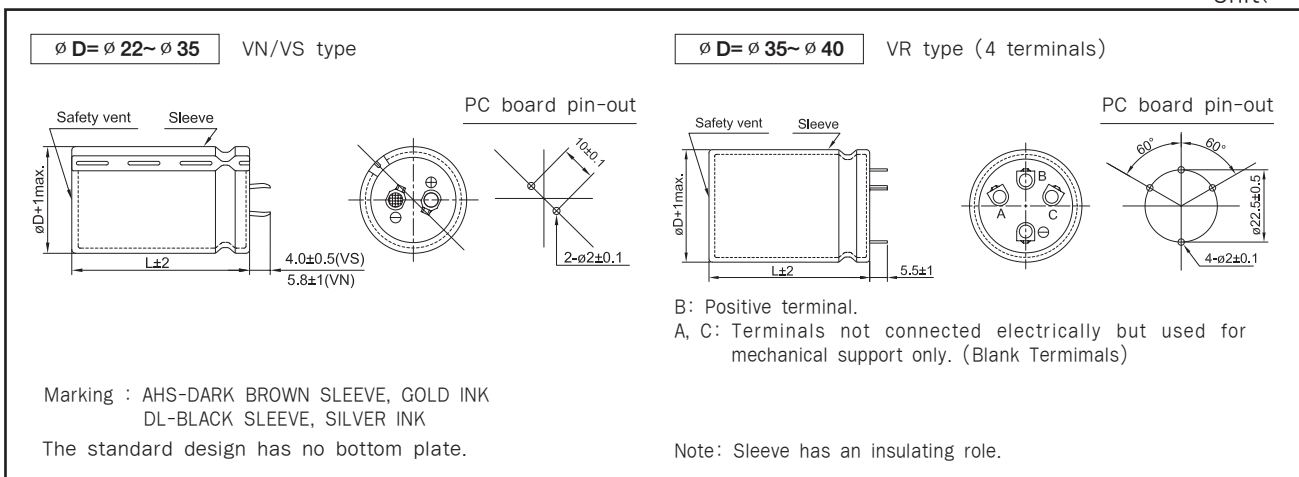

CAUTION: Please use the blank terminals for mechanical support only. The blank terminals must not be connected to a solder trace on the PC board, but be electrically isolated from negative or positive terminal.

RATINGS OF AHS Series

μF \ V _{DC}	50			63			80			100		
3,300	25.4 × 30	0.20	1.84	25.4 × 40	0.20	1.96	25.4 × 50	0.15	2.39	30 × 60	0.15	2.68
	30 × 25	0.20	1.86	30 × 30	0.20	1.96	30 × 40	0.15	2.40	35 × 50	0.15	2.69
							35 × 35	0.15	2.40	40 × 40	0.15	2.68
4,700	25.4 × 40	0.20	2.34	25.4 × 50	0.20	2.47	25.4 × 60	0.15	3.01	35 × 60	0.15	2.98
	30 × 30	0.20	2.36	30 × 40	0.20	2.48	30 × 50	0.15	3.04	40 × 50	0.20	2.92
				35 × 30	0.20	2.48	35 × 40	0.15	3.02			
6,800	25.4 × 50	0.22	2.83	30 × 50	0.22	3.02	30 × 60	0.15	3.35	40 × 60	0.20	3.68
	30 × 40	0.22	2.85	35 × 40	0.22	3.00	35 × 50	0.15	3.35			
	35 × 35	0.25	2.67				40 × 40	0.20	3.34			
8,200	30 × 50	0.25	3.11	30 × 60	0.25	3.27	35 × 60	0.20	3.87			
	35 × 40	0.25	3.09	35 × 50	0.25	3.28	40 × 50	0.20	3.86			
				40 × 40	0.25	3.28						
10,000	30 × 50	0.25	3.43	35 × 60	0.25	3.82	40 × 60	0.20	4.46			
	35 × 40	0.25	3.41	40 × 50	0.25	3.81						
12,000	30 × 60	0.25	3.66	35 × 60	0.25	4.19						
	35 × 50	0.30	3.62	40 × 50	0.25	4.18						
	40 × 40	0.30	3.62									
15,000	35 × 60	0.30	4.27	40 × 60	0.30	4.46						
	40 × 50	0.30	4.26									
22,000	40 × 60	0.30	5.40									

↑ Rated Ripple Current (Arms/85°C, 120Hz)
 ↑ Tan δ (Max.)
 ↑ Case Size $\phi D \times L$ (mm)

Frequency vs. Impedance Graph

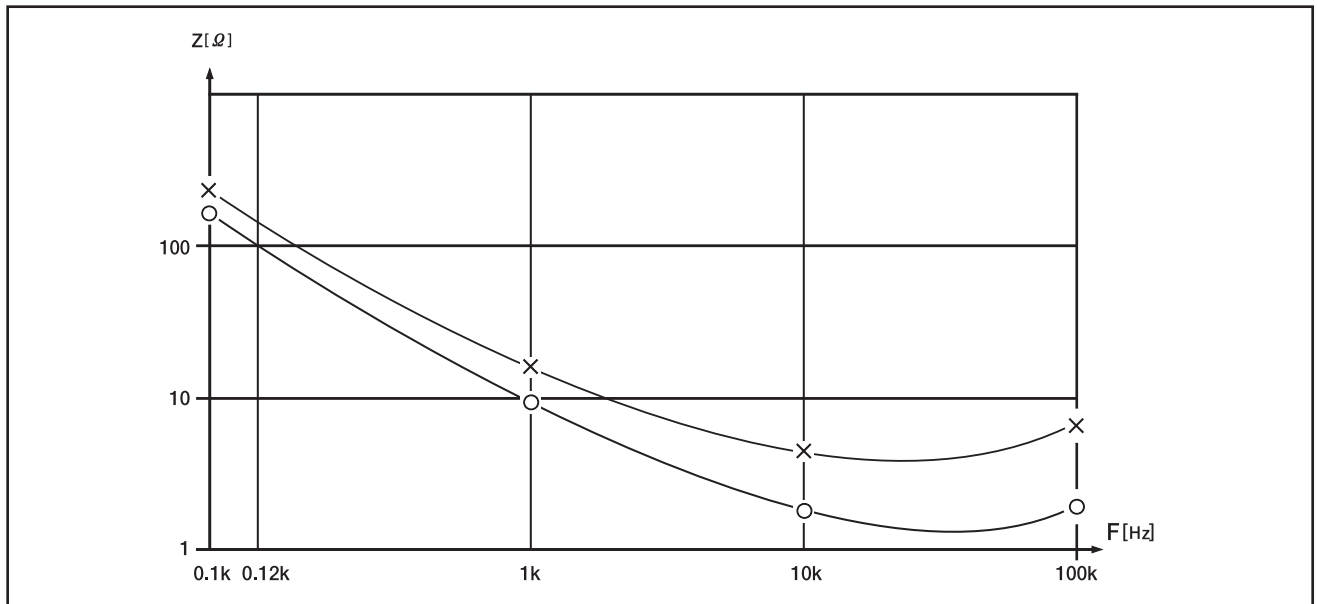

○ - ○ AHS 80 VR 8200
 × - × DL 80 VR 8200

TZF Series

• 105°C 2,000Hrs assured.

- Non-solvent proof
- This series adopts the electrolyte which was excellent in fire retardancy compared with the conventional series
- For SMPS, Inverter
- RoHS compliant.
- Halogen-free capacitors are also available.



SPECIFICATIONS

Item	Characteristics				
Rated Voltage	400~450 V _{DC}				
Operating Temperature Range	-25 ~ +105°C				
Capacitance Tolerance	±20% (M) (at 20°C, 120Hz)				
Leakage Current	I=0.02CV(µA) or 3mA, whichever is smaller. Where, I : Max. Leakage current(µA) C : Nominal capacitance(µF) V : Rated voltage(V _{DC}) (at 20°C , 5minutes)				
Dissipation Factor(Tanδ)	<table border="1"> <tr> <td>Rated Voltage(V_{DC})</td> <td>400~450</td> </tr> <tr> <td>Tanδ(Max.)</td> <td>0.20</td> </tr> </table> (at 20°C, 120Hz)	Rated Voltage(V _{DC})	400~450	Tanδ(Max.)	0.20
Rated Voltage(V _{DC})	400~450				
Tanδ(Max.)	0.20				
Temperature Characteristics (Max. Impedance ratio)	<table border="1"> <tr> <td>Rated Voltage(V_{DC})</td> <td>400~450</td> </tr> <tr> <td>Z(-25°C)/Z(20°C)</td> <td>8</td> </tr> </table> (at 120Hz)	Rated Voltage(V _{DC})	400~450	Z(-25°C)/Z(20°C)	8
Rated Voltage(V _{DC})	400~450				
Z(-25°C)/Z(20°C)	8				
Load Life	The following specifications shall be satisfied when the capacitors are restored to 20°C after the rated voltage with the rated ripple current is applied for 2,000 hours at 105°C. Capacitance change ≤ ±20 % of the initial value tan δ ≤ 200 % of the initial specified value Leakage current ≤ The initial specified value				
Shelf Life	The following specifications shall be satisfied when the capacitors are restored to 20°C after exposing them for 1,000 hours at 105°C without voltage applied. The rated voltage shall be applied to the capacitors for a minimum of 30 minutes, at least 24 hours and not more than 48 hours before the measurements. Capacitance change ≤ ±20 % of the initial value tan δ ≤ 200 % of the initial specified value Leakage current ≤ 500 % of the initial specified value				
Others	Satisfied characteristics KS C IEC 60384-4				

■ The specifications and the size depend on the safety requirement.(flame retardant)
Please consult us for any further details.

DIMENSIONS OF TZF Series

Unit(mm)

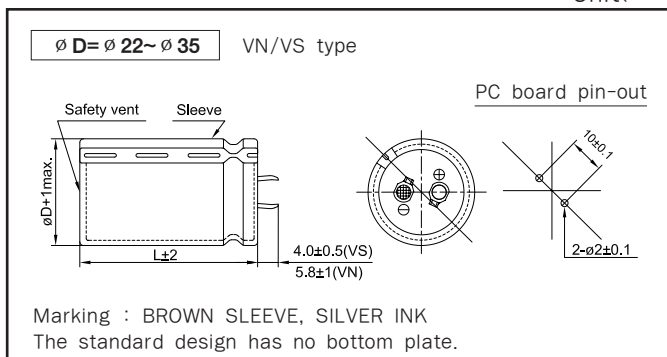

TGA(KMH) Series

• 105°C 2,000Hrs assured.

- Non-solvent proof.
- Wide Temperature range.
- For UPS.
- RoHS compliant.



SPECIFICATIONS

Item	Characteristics										
Rated Voltage Range	10 ~ 100 V _{DC}	160 ~ 450 V _{DC}									
Operating Temperature Range	-40 ~ +105°C	-25 ~ +105°C									
Capacitance Tolerance	±20%(M) (at 20°C, 120Hz)										
Leakage Current	I = 0.02CV or 5mA, whichever is smaller. Where, I: Leakage current (µA) C: Nominal capacitance (µF) V: Rated voltage (V _{DC}) (at 20°C, 5 minutes)										
Dissipation Factor(Tanδ)	Tanδ shall not exceed the values shown in the RATINGS. (at 20°C, 120Hz)										
Temperature Characteristics (Capacitance change ratio)	<table border="1" style="margin-left: auto; margin-right: auto;"> <thead> <tr> <th>Rated Voltage(V_{DC})</th> <th>10~100</th> <th>160~450</th> </tr> </thead> <tbody> <tr> <td>C(-25°C)/C(20°C)</td> <td>-</td> <td>≥0.7</td> </tr> <tr> <td>C(-40°C)/C(20°C)</td> <td>≥0.6</td> <td>-</td> </tr> </tbody> </table> (at 120Hz)		Rated Voltage(V _{DC})	10~100	160~450	C(-25°C)/C(20°C)	-	≥0.7	C(-40°C)/C(20°C)	≥0.6	-
Rated Voltage(V _{DC})	10~100	160~450									
C(-25°C)/C(20°C)	-	≥0.7									
C(-40°C)/C(20°C)	≥0.6	-									
Load Life	The following specifications shall be satisfied when the capacitors are restored to 20°C after the rated voltage with the rated ripple current is applied (the peak voltage shall not exceed the rated voltage) for 2,000 hours at 105°C. Capacitance change ≤ ±20% of the initial value Tanδ ≤ 200% of the initial specified value Leakage current ≤ The initial specified value										
Shelf Life	The following specifications shall be satisfied when the capacitors are restored to 20°C after the exposing them at 105°C for 500 hours without voltage applied. The rated voltage shall be applied to the capacitors for a minimum of 30 minutes, at least 24 hours and not more than 48 hours before the measurements. Capacitance change ≤ ±20% of the initial value Tanδ ≤ 200% of the initial specified value Leakage current ≤ The initial specified value										
Others	Satisfied characteristics KS C IEC 60384-4										

DIMENSIONS OF TGA(KMH) Series

Unit(mm)

Marking : BROWN SLEEVE, SILVER INK

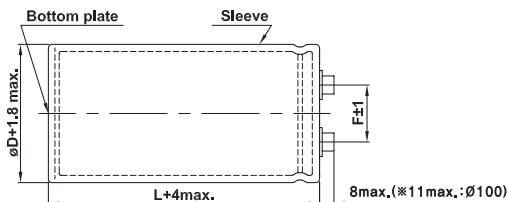

<Screw specifications>

∅D = ∅35 ~ ∅89

● Plus hexagon-headed screw:
M5×0.8×12

● Maximum screw tightening torque: 3.23N·m (33kg·cm)

∅D = ∅100

● Cross-recessed head (Phillips) screw:
M8×1.25×16

Spring washer, Washer

● Maximum screw tightening torque:
6.31N·m(64kg·cm)

B type mounting clamp

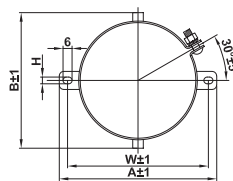

∅D	A	B	W	H	F
35	58	44	48	3.5	12.7
50	78	64	68	4.5	22.4
63.5	90	75	80	4.5	28.0
76.5	104.5	90	93.5	4.5	31.5

C type mounting clamp

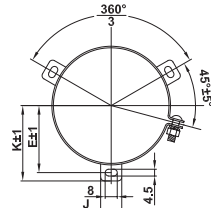

∅D	E	K	J	F
50	32.5	37.0	14	22.4
63.5	38.1	43.5	14	28.0
76.5	44.5	50.0	14	31.5
89	50.8	56.5	16	31.5
100	56.5	63.4	18	41.5

RATINGS OF TGA(KMH) Series

VDC	Capacitance (μF)	∅D×L(mm)	Tanδ	Rated Ripple Current (Arms/105°C, 120Hz)
10	22,000	35 × 50	0.70	4.9
	27,000	35 × 50	0.70	5.1
	33,000	35 × 60	0.70	5.9
	39,000	35 × 80	0.70	6.3
	47,000	35 × 80	0.70	6.9
	56,000	35 × 80	0.70	7.4
	68,000	35 × 100	0.70	8.5
	82,000	35 × 100	0.70	8.9
	100,000	35 × 120	0.70	10.7
	120,000	50 × 80	0.75	11.0
	150,000	50 × 100	0.80	13.2
	180,000	50 × 120	0.80	15.7
	220,000	50 × 120	0.85	16.8
	270,000	63.5 × 120	1.00	19.6
	330,000	63.5 × 120	1.20	19.7
	390,000	76.5 × 120	1.50	21.3
470,000	76.5 × 120	1.80	21.4	
560,000	76.5 × 140	2.00	23.6	
680,000	89 × 140	2.40	26.0	
16	18,000	35 × 50	0.45	4.2
	22,000	35 × 50	0.45	4.7
	27,000	35 × 60	0.45	5.5
	33,000	35 × 60	0.45	5.7
	39,000	35 × 80	0.45	6.8
	47,000	35 × 80	0.50	7.1
	56,000	35 × 100	0.50	8.4
	68,000	35 × 100	0.55	8.8
	82,000	50 × 80	0.55	10.7
	100,000	50 × 80	0.65	10.8
	120,000	50 × 100	0.65	13.1
	150,000	50 × 120	0.70	15.3
	180,000	50 × 120	0.80	15.7
	220,000	63.5 × 120	0.85	19.2
	270,000	63.5 × 120	1.00	19.6
	330,000	76.5 × 120	1.30	21.1
390,000	76.5 × 120	1.50	21.3	
470,000	76.5 × 140	1.60	24.2	
560,000	89 × 140	2.00	28.1	
680,000	89 × 140	2.40	28.5	
25	12,000	35 × 50	0.35	3.7
	15,000	35 × 50	0.35	4.1
	18,000	35 × 60	0.35	4.8
	22,000	35 × 60	0.35	5.3
	27,000	35 × 80	0.35	6.4
	33,000	35 × 80	0.40	6.7
	39,000	35 × 100	0.40	7.8
	47,000	35 × 120	0.40	9.3
	56,000	50 × 80	0.45	9.7
	68,000	50 × 100	0.45	10.7
	82,000	50 × 100	0.50	11.2
	100,000	50 × 120	0.50	14.8
	120,000	63.5 × 100	0.65	14.9
	150,000	63.5 × 120	0.65	17.9
	180,000	63.5 × 120	0.80	18.9
	220,000	76.5 × 120	0.85	21.3
270,000	76.5 × 120	1.00	21.7	
330,000	76.5 × 140	1.20	23.1	
390,000	89 × 140	1.50	24.9	
35	8,200	35 × 50	0.30	3.3
	10,000	35 × 50	0.30	3.6
	12,000	35 × 60	0.30	4.2
	15,000	35 × 60	0.30	4.7
	18,000	35 × 80	0.30	5.7
	22,000	35 × 80	0.30	6.8
	27,000	35 × 100	0.30	7.5
	33,000	35 × 120	0.30	9.0

VDC	Capacitance (μF)	∅D×L(mm)	Tanδ	Rated Ripple Current (Arms/105°C, 120Hz)
35	39,000	50 × 80	0.35	9.2
	47,000	50 × 100	0.35	11.2
	56,000	50 × 100	0.40	11.4
	68,000	50 × 120	0.40	13.6
	82,000	63.5 × 100	0.45	14.8
	100,000	63.5 × 120	0.45	16.5
	120,000	63.5 × 120	0.55	17.6
	150,000	76.5 × 120	0.65	18.5
	180,000	76.5 × 120	0.80	19.8
	220,000	76.5 × 140	0.80	23.4
	270,000	89 × 140	1.00	25.5
	50	3,900	35 × 50	0.20
4,700		35 × 50	0.20	3.1
5,600		35 × 50	0.20	3.3
6,800		35 × 50	0.25	3.5
8,200		35 × 60	0.25	3.8
10,000		35 × 80	0.25	4.6
12,000		35 × 80	0.25	5.1
15,000		35 × 80	0.25	5.7
18,000		35 × 80	0.25	6.0
22,000		35 × 100	0.25	6.7
27,000		50 × 80	0.25	9.1
33,000		50 × 100	0.25	11.1
39,000		50 × 120	0.25	13.1
47,000		50 × 120	0.30	13.9
56,000		63.5 × 100	0.35	14.9
68,000		63.5 × 120	0.35	16.6
82,000	76.5 × 120	0.40	18.9	
100,000	76.5 × 120	0.45	19.5	
120,000	76.5 × 120	0.55	21.0	
150,000	89 × 140	0.60	23.9	
180,000	89 × 140	0.75	24.0	
63	2,700	35 × 50	0.20	2.3
	3,300	35 × 50	0.20	2.5
	3,900	35 × 50	0.20	2.8
	4,700	35 × 50	0.20	3.1
	5,600	35 × 60	0.20	3.5
	6,800	35 × 60	0.20	3.9
	8,200	35 × 80	0.20	4.7
	10,000	35 × 80	0.25	4.9
	12,000	35 × 100	0.25	5.5
	15,000	35 × 120	0.25	6.6
	18,000	35 × 120	0.25	6.9
	22,000	50 × 80	0.25	7.4
	27,000	50 × 120	0.25	10.9
	33,000	50 × 120	0.25	12.0
	39,000	63.5 × 100	0.30	12.5
	47,000	63.5 × 120	0.30	14.9
56,000	63.5 × 120	0.30	16.3	
68,000	76.5 × 120	0.35	18.4	
82,000	76.5 × 140	0.40	20.0	
100,000	76.5 × 140	0.50	20.5	
120,000	89 × 140	0.60	21.8	
80	2,200	35 × 50	0.15	2.4
	2,700	35 × 50	0.15	2.7
	3,300	35 × 50	0.15	3.0
	3,900	35 × 60	0.15	3.4
	4,700	35 × 60	0.15	3.7
	5,600	35 × 80	0.15	4.5
	6,800	35 × 80	0.15	4.9
	8,200	35 × 100	0.20	5.1
	10,000	35 × 120	0.20	6.1
	12,000	50 × 80	0.20	6.7
	15,000	50 × 100	0.20	8.3
	18,000	50 × 120	0.20	9.9
22,000	50 × 120	0.20	11.0	

RATINGS OF TGA(KMH) Series

VDC	Capacitance (μF)	∅D×L(mm)	Tanδ	Rated Ripple Current (Arms/105°C, 120Hz)	VDC	Capacitance (μF)	∅D×L(mm)	Tanδ	Rated Ripple Current (Arms/105°C, 120Hz)
80	27,000	63.5 × 100	0.25	11.4	200	12,000	76.5 × 120	0.20	10.2
	33,000	76.5 × 100	0.25	13.9		15,000	76.5 × 120	0.20	11.2
	39,000	76.5 × 100	0.30	14.5		18,000	89 × 140	0.25	13.1
	47,000	76.5 × 120	0.30	16.5	250	270	35 × 50	0.15	0.8
	56,000	76.5 × 120	0.30	18.1		330	35 × 50	0.15	0.9
	68,000	76.5 × 140	0.35	19.7		390	35 × 50	0.15	1.0
82,000	89 × 140	0.40	22.1	470		35 × 50	0.15	1.1	
100	1,800	35 × 50	0.10	2.7		560	35 × 50	0.15	1.2
	2,200	35 × 50	0.10	3.0		680	35 × 60	0.15	1.4
	2,700	35 × 60	0.10	3.5		820	35 × 80	0.15	1.6
	3,300	35 × 80	0.10	4.2		1,000	35 × 80	0.20	1.7
	3,900	35 × 80	0.12	4.5		1,200	35 × 80	0.20	1.8
	4,700	35 × 100	0.12	5.0		1,500	35 × 100	0.20	2.1
	5,600	35 × 100	0.12	5.4		1,800	35 × 120	0.20	2.5
	6,800	35 × 120	0.15	5.8		2,200	35 × 120	0.20	2.8
	8,200	50 × 80	0.15	6.4		2,700	50 × 100	0.20	3.5
	10,000	50 × 100	0.15	7.8		3,300	50 × 120	0.20	4.2
	12,000	50 × 120	0.15	9.3		3,900	50 × 120	0.20	4.6
	15,000	50 × 120	0.15	10.4	4,700	63.5 × 120	0.20	5.7	
	18,000	63.5 × 100	0.20	11.0	5,600	63.5 × 120	0.20	6.3	
	22,000	63.5 × 120	0.20	12.5	6,800	76.5 × 120	0.20	7.7	
	27,000	76.5 × 120	0.25	13.7	8,200	76.5 × 120	0.20	8.4	
33,000	76.5 × 120	0.25	15.2	10,000	76.5 × 140	0.20	10.0		
39,000	76.5 × 140	0.30	16.1	12,000	89 × 140	0.20	11.9		
47,000	89 × 140	0.30	19.3	15,000	89 × 140	0.20	12.2		
56,000	89 × 140	0.30	21.1	315	180	35 × 50	0.10	0.8	
160	560	35 × 50	0.15		1.2	220	35 × 50	0.10	0.9
	680	35 × 50	0.15		1.3	270	35 × 50	0.10	1.0
	820	35 × 50	0.15		1.4	330	35 × 50	0.10	1.1
	1,000	35 × 50	0.15		1.6	390	35 × 50	0.10	1.2
	1,200	35 × 60	0.15		1.9	470	35 × 60	0.10	1.4
	1,500	35 × 60	0.15		2.1	560	35 × 60	0.10	1.5
	1,800	35 × 80	0.15		2.5	680	35 × 80	0.10	1.6
	2,200	35 × 80	0.15		2.8	820	35 × 80	0.15	1.7
	2,700	35 × 100	0.15		3.3	1,000	35 × 100	0.15	2.0
	3,300	35 × 120	0.15		3.8	1,200	35 × 120	0.15	2.4
	3,900	50 × 80	0.20		3.9	1,500	50 × 80	0.15	2.7
	4,700	50 × 100	0.20		4.6	1,800	50 × 100	0.15	3.3
	5,600	50 × 100	0.20		5.1	2,200	50 × 100	0.15	4.0
	6,800	50 × 120	0.20		6.1	2,700	50 × 120	0.15	4.4
	8,200	63.5 × 100	0.20	7.0	3,300	63.5 × 100	0.15	5.1	
10,000	63.5 × 120	0.20	8.4	3,900	63.5 × 120	0.15	6.0		
12,000	76.5 × 100	0.20	9.4	4,700	76.5 × 100	0.15	6.8		
15,000	76.5 × 120	0.20	11.4	5,600	76.5 × 120	0.15	8.0		
18,000	76.5 × 140	0.20	13.4	6,800	89 × 130	0.15	9.2		
22,000	89 × 140	0.25	14.5	8,200	89 × 140	0.15	11.4		
27,000	89 × 140	0.25	16.0	10,000	89 × 140	0.15	12.6		
200	330	35 × 50	0.15	0.9	350	180	35 × 50	0.10	0.8
	390	35 × 50	0.15	1.0		220	35 × 50	0.10	0.9
	470	35 × 50	0.15	1.1		270	35 × 50	0.10	1.0
	560	35 × 50	0.15	1.2		330	35 × 50	0.10	1.1
	680	35 × 50	0.15	1.3		390	35 × 50	0.10	1.1
	820	35 × 50	0.15	1.4		470	35 × 60	0.10	1.4
	1,000	35 × 60	0.15	1.7		560	35 × 80	0.10	1.6
	1,200	35 × 60	0.15	1.9		680	35 × 80	0.15	1.6
	1,500	35 × 80	0.15	2.3		820	35 × 100	0.15	1.8
	1,800	35 × 80	0.15	2.5		1,000	35 × 120	0.15	2.2
	2,200	35 × 100	0.15	2.7		1,200	50 × 80	0.15	2.4
	2,700	35 × 120	0.15	3.6		1,500	50 × 100	0.15	3.0
	3,300	50 × 80	0.15	4.1		1,800	50 × 120	0.15	3.6
	3,900	50 × 100	0.15	4.9		2,200	50 × 120	0.15	4.0
	4,700	63.5 × 100	0.20	5.3		2,700	63.5 × 100	0.15	4.6
5,600	63.5 × 100	0.20	5.8	3,900	76.5 × 120	0.15	6.7		
6,800	63.5 × 120	0.20	6.9	5,600	76.5 × 130	0.15	8.3		
8,200	63.5 × 120	0.20	7.6	6,800	76.5 × 140	0.15	9.5		
10,000	76.5 × 120	0.20	9.3	8,200	89 × 140	0.15	11.4		

RATINGS OF TGA(KMH) Series

VDC	Capacitance (μF)	∅D×L(mm)	Tanδ	Rated Ripple Current (Arms/105°C, 120Hz)
400	180	35 × 50	0.10	0.8
	220	35 × 50	0.10	0.9
	270	35 × 50	0.10	1.0
	330	35 × 60	0.10	1.2
	390	35 × 60	0.10	1.2
	470	35 × 80	0.10	1.4
	560	35 × 80	0.15	1.4
	680	35 × 100	0.15	1.7
	820	35 × 120	0.15	2.0
	1,000	50 × 80	0.15	2.2
	1,200	50 × 100	0.15	2.7
	1,500	50 × 120	0.15	3.3
	2,200	63.5 × 100	0.15	4.2
	3,300	63.5 × 120	0.15	5.5
	4,700	76.5 × 130	0.15	7.6
	5,600	89 × 140	0.15	9.4
	6,800	89 × 140	0.15	10.4
18,000	100 × 220	0.15	21.9	
22,000	100 × 250	0.15	25.6	

VDC	Capacitance (μF)	∅D×L(mm)	Tanδ	Rated Ripple Current (Arms/105°C, 120Hz)
450	1,000	50 × 80	0.15	2.0
	1,200	50 × 100	0.15	2.5
	1,500	50 × 120	0.15	3.1
	1,800	50 × 120	0.15	3.4
	2,200	63.5 × 100	0.15	3.9
	3,300	63.5 × 120	0.15	5.2
	3,900	76.5 × 120	0.15	5.9
	4,700	76.5 × 130	0.15	7.2
	5,600	89 × 140	0.15	8.9
	15,000	100 × 220	0.15	18.9
	18,000	100 × 250	0.15	22.0

RATED RIPPLE CURRENT

Frequency Multiplying Factor

Vdc	∅D(mm)	Frequency(Hz)				
		60	120	300	1k	10k~
10 ~ 50	∅35 ~ ∅100	0.95	1.00	1.03	1.05	1.09
63 ~ 80	∅35	0.90	1.00	1.06	1.10	1.08
	∅50 ~ ∅100	0.95	1.00	1.03	1.05	1.09
100	∅35	0.82	1.00	1.12	1.22	1.30
	∅50	0.90	1.00	1.06	1.10	1.18
	∅63.5 ~ ∅100	0.95	1.00	1.03	1.05	1.09
160 ~ 250	∅35	0.80	1.00	1.19	1.34	1.46
	∅50 ~ ∅63.5	0.81	1.00	1.14	1.26	1.36
	∅76.5 ~ ∅100	0.82	1.00	1.12	1.22	1.30
315 ~ 450	∅35 ~ ∅100	0.80	1.00	1.19	1.34	1.46

RGB Series

• 85°C 2,000Hrs assured.

- Non-solvent proof.
- General.
- RoHS compliant.

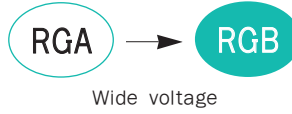

SPECIFICATIONS

Item	Characteristics	
Rated Voltage Range	16 ~ 100 V _{DC}	160 ~ 650 V _{DC}
Operating Temperature Range	-40 ~ +85°C	-25 ~ +85°C
Capacitance Tolerance	±20% (M) (at 20°C, 120Hz)	
Leakage Current	I = 0.02CV or 5mA, whichever is smaller. Where, I: Max. Leakage current (μA) C: Nominal capacitance (μF) V: Rated voltage (V _{DC}) (at 20°C, 5 minutes)	
Dissipation Factor(Tanδ)	Tanδ shall not exceed the values shown in the RATINGS. (at 20°C, 120Hz)	
Insulation Withstanding Voltage	When a voltage of 2,000V _{AC} is applied for one minute between the terminals shorted each other and the mounting clamp on the insulating sleeve covering the case, there shall not be electrical damage.	
Load Life	The following specifications shall be satisfied when the capacitors are restored to 20°C. after subjected to DC voltage with the rated ripple current is applied (the peak voltage shall not exceed the rated voltage) 2,000 hours at 85°C. Capacitance change ≤ ±20% of the initial value Tanδ ≤ 300% of the initial specified value Leakage current ≤ The initial specified value	
Shelf Life	The following specifications shall be satisfied when the capacitors are restored to 20°C after the exposing them at 85°C for 500 hours without voltage applied. The rated voltage shall be applied to the capacitors for a minimum of 30 minutes, at least 24 hours and not more than 48 hours before the measurements. Capacitance change ≤ ±20% of the initial value Tanδ ≤ 300% of the initial specified value Leakage current ≤ The initial specified value	
Others	Satisfied characteristics KS C IEC 60384-4	

DIMENSIONS OF RGB Series

Unit(mm)

Marking:BLACK SLEEVE, SILVER INK.

B type mounting clamp

øD	A	B	W	H	F
35	58	44	48	3.5	12.7
50	78	64	68	4.5	22.4
63.5	90	75	80	4.5	28.0
76.5	104.5	90	93.5	4.5	31.5

C type mounting clamp

øD	E	K	J	F
50	32.5	37.0	14	22.4
63.5	38.1	43.5	14	28.0
76.5	44.5	50.0	14	31.5
89	50.8	56.5	16	31.5
100	56.5	63.4	18	41.5

<Screw specifications>
 øD = ø 35 ~ ø 89 ● Cross-recessed head (Phillips) screw:
 ● Plus hexagon-headed screw: M5 × 0.8 × 12 M8 × 1.25 × 16
 ● Maximum screw tightening torque: 3.23N · m (33kg · cm) Spring washer, Washer
 ● Maximum screw tightening torque: 6.31N · m (64kg · cm)

RATINGS OF RGB Series

VDC	Capacitance (μF)	∅D×L(mm)	Tanδ	Rated Ripple Current (Arms/85°C, 120Hz)	VDC	Capacitance (μF)	∅D×L(mm)	Tanδ	Rated Ripple Current (Arms/85°C, 120Hz)
16	47,000	35×80	0.70	8.8	80	6,800	35×60	0.30	4.9
	68,000	35×100	0.70	11.5		10,000	35×80	0.30	6.3
	100,000	50×80	1.00	12.9		15,000	35×120	0.30	8.2
	150,000	50×100	1.00	16.2		22,000	50×80	0.35	9.3
	220,000	50×130	1.00	21.3		33,000	50×120	0.35	13.1
	330,000	63.5×120	1.30	23.1		47,000	63.5×100	0.40	15.5
	470,000	76.5×120	2.00	24.7		68,000	63.5×140	0.40	17.7
	680,000	76.5×160	2.00	33.9		100,000	76.5×140	0.45	23.6
25	33,000	35×80	0.45	8.2	100	4,700	35×60	0.20	4.5
	47,000	35×100	0.45	10.8		6,800	35×80	0.20	5.9
	68,000	50×80	0.60	12.7		10,000	35×100	0.20	7.7
	100,000	50×100	0.60	14.5		15,000	50×80	0.25	8.6
	150,000	50×130	0.60	18.8		22,000	50×100	0.25	11.3
	220,000	63.5×120	0.80	22.0		33,000	50×140	0.25	14.7
	330,000	76.5×120	1.60	23.7		47,000	63.5×140	0.30	17.0
	470,000	76.5×160	1.60	29.5		68,000	76.5×140	0.40	21.5
35	22,000	35×70	0.45	7.0	160	1,500	35×60	0.15	3.4
	33,000	35×100	0.45	9.3		2,200	35×80	0.15	4.6
	47,000	35×120	0.45	12.2		3,300	35×100	0.15	6.2
	68,000	50×100	0.60	14.3		4,700	50×80	0.15	7.7
	100,000	50×120	0.60	17.1		6,800	50×100	0.15	10.0
	150,000	63.5×120	0.70	19.6		10,000	50×140	0.15	14.1
	220,000	76.5×120	0.90	23.3		15,000	63.5×140	0.20	16.5
	330,000	76.5×160	0.90	27.8		22,000	76.5×140	0.25	17.6
50	10,000	35×60	0.30	5.2	200	1,000	35×60	0.15	2.8
	15,000	35×80	0.30	6.6		1,500	35×70	0.15	3.6
	22,000	35×100	0.30	8.7		2,200	35×100	0.15	5.1
	33,000	35×120	0.30	11.4		3,300	35×120	0.15	6.7
	47,000	50×100	0.45	13.2		4,700	50×100	0.15	8.3
	68,000	50×120	0.45	15.9		6,800	50×140	0.15	11.5
	100,000	63.5×120	0.50	18.8		10,000	63.5×120	0.20	12.1
	150,000	76.5×120	0.70	21.5		15,000	76.5×120	0.25	13.7
220,000	76.5×160	0.70	26.6	22,000	76.5×160	0.25	18.6		
63	6,800	35×50	0.30	4.5	250	680	35×50	0.15	2.1
	10,000	35×60	0.30	5.4		1,000	35×70	0.15	2.9
	15,000	35×80	0.30	6.9		1,500	35×80	0.15	3.8
	22,000	35×120	0.30	9.8		2,200	35×120	0.15	5.5
	33,000	50×100	0.45	12.5		3,300	50×100	0.15	7.0
	47,000	50×120	0.45	14.8		4,700	50×140	0.15	9.6
	68,000	63.5×100	0.50	16.6		6,800	63.5×120	0.20	10.0
	100,000	76.5×120	0.70	20.6		10,000	76.5×120	0.25	11.2
	150,000	76.5×140	0.70	24.0		15,000	76.5×160	0.25	15.3

RATED RIPPLE CURRENT

Frequency Multiplying Factor

Vdc	∅D(mm)	Frequency(Hz)				
		60	120	300	1k	10k~
16 ~ 50	∅35 ~ ∅100	0.95	1.00	1.03	1.05	1.09
63 ~ 80	∅35	0.90	1.00	1.06	1.10	1.08
	∅50 ~ ∅100	0.95	1.00	1.03	1.05	1.09
100	∅35	0.82	1.00	1.12	1.22	1.30
	∅50	0.90	1.00	1.06	1.10	1.18
	∅63.5 ~ ∅100	0.95	1.00	1.03	1.05	1.09
160 ~ 250	∅35	0.80	1.00	1.19	1.34	1.46
	∅50 ~ ∅63.5	0.81	1.00	1.14	1.26	1.36
	∅76.5 ~ ∅100	0.82	1.00	1.12	1.22	1.30
350 ~ 650	∅35 ~ ∅100	0.80	1.00	1.19	1.34	1.46



LARGE SIZED ALUMINUM ELECTROLYTIC CAPACITORS

RATINGS OF RGB Series

VDC	Capacitance (μF)	∅D×L(mm)	Tanδ	Rated Ripple Current (Arms/85°C, 120Hz)	VDC	Capacitance (μF)	∅D×L(mm)	Tanδ	Rated Ripple Current (Arms/85°C, 120Hz)
350	390	35×50	0.25	1.9	550	100	35×50	0.25	0.6
	680	35×80	0.25	2.9		180	35×80	0.25	1.0
	1,000	35×100	0.25	3.8		270	35×100	0.25	1.3
	1,200	35×120	0.25	4.2		330	35×120	0.25	1.6
	1,500	50×75	0.25	4.7		390	50×75	0.25	1.7
	2,200	50×100	0.25	6.3		560	50×95	0.25	2.1
	3,300	50×130	0.25	8.8		560	63.5×95	0.25	2.5
	3,300	63.5×95	0.25	8.8		680	50×115	0.25	2.7
	3,900	63.5×120	0.25	10.3		680	63.5×120	0.25	3.0
	4,700	63.5×130	0.25	12.0		820	50×130	0.25	3.1
	4,700	76.5×100	0.25	11.7		820	63.5×130	0.25	3.5
	5,600	76.5×115	0.25	12.6		1,200	76.5×95	0.25	4.2
	6,800	76.5×130	0.25	15.9		1,500	76.5×120	0.25	5.0
	8,200	76.5×155	0.25	19.0		1,800	76.5×130	0.25	5.8
	12,000	89×155	0.25	22.5		2,200	76.5×150	0.25	7.0
	22,000	100×220	0.25	38.0		3,300	89×160	0.25	9.3
	27,000	100×250	0.25	44.6		8,200	100×220	0.25	18.0
400	330	35×50	0.25	1.7	10,000	100×250	0.25	21.2	
	560	35×80	0.25	2.7	600	180	35×100	0.25	1.1
	820	35×100	0.25	3.4		270	35×120	0.25	1.4
	1,000	35×120	0.25	3.9		330	50×75	0.25	1.7
	1,200	50×75	0.25	4.2		390	50×95	0.25	1.8
	1,800	50×100	0.25	5.7		390	63.5×95	0.25	2.1
	2,200	50×130	0.25	7.2		560	50×115	0.25	2.2
	2,700	63.5×95	0.25	7.9		560	63.5×115	0.25	2.6
	3,300	63.5×120	0.25	9.5		680	50×130	0.25	2.9
	3,900	63.5×130	0.25	10.9		680	63.5×130	0.25	3.2
	3,900	76.5×100	0.25	10.6		820	76.5×95	0.25	3.3
	4,700	76.5×115	0.25	12.6		1,200	76.5×115	0.25	4.4
	5,600	76.5×130	0.25	14.5		1,500	76.5×130	0.25	5.4
	6,800	76.5×155	0.25	17.3		1,800	76.5×150	0.25	6.5
	10,000	89×155	0.25	20.5		2,200	89×130	0.25	7.8
	18,000	100×220	0.25	34.4		2,700	89×155	0.25	8.9
	22,000	100×250	0.25	40.3		4,700	100×220	0.25	14.7
450	270	35×50	0.25	1.6		5,600	100×250	0.25	17.0
	470	35×80	0.25	2.4	650	82	35×60	0.25	0.6
	680	35×100	0.25	3.1		120	35×80	0.25	0.9
	820	35×120	0.25	3.5		390	50×80	0.25	1.8
	1,000	50×75	0.25	3.9		470	50×100	0.25	2.5
	1,200	50×100	0.25	4.7		820	63.5×100	0.25	3.2
	1,500	50×115	0.25	5.6		1,200	63.5×130	0.25	4.2
	1,800	50×130	0.25	6.5		1,500	63.5×170	0.25	5.0
	2,200	63.5×95	0.25	7.2		2,700	76.5×150	0.25	7.2
	2,700	63.5×120	0.25	8.6		3,300	76.5×190	0.25	8.3
	3,300	63.5×130	0.25	10.0		3,900	89×170	0.25	10.5
	3,300	76.5×100	0.25	9.8		4,700	89×190	0.25	12.0
	3,900	76.5×115	0.25	11.5					
	4,700	76.5×130	0.25	13.3					
	5,600	76.5×155	0.25	15.7					
	8,200	89×155	0.25	18.6					
	15,000	100×220	0.25	31.4					
18,000	100×250	0.25	36.4						
500	120	35×50	0.25	0.7					
	270	35×80	0.25	1.2					
	330	35×100	0.25	1.4					
	390	35×120	0.25	1.7					
	470	50×75	0.25	1.8					
	680	50×90	0.25	2.5					
	820	50×120	0.25	2.9					
	1,000	50×130	0.25	3.4					
	1,000	63.5×95	0.25	3.4					
	1,500	63.5×120	0.25	4.5					
	1,500	76.5×95	0.25	4.6					
	1,800	63.5×130	0.25	5.2					
	2,200	76.5×120	0.25	6.1					
	2,700	76.5×160	0.25	7.7					
	3,900	89×160	0.25	10.1					
	12,000	100×220	0.25	21.7					
	15,000	100×250	0.25	25.7					

Note : When long life performance is required in actual use, the rms ripple current has to be reduced.

RFC(RWF) Series

• 85°C 5,000Hrs assured.

- Non-solvent proof.
- High Ripple Capability.
- Long Life.
- For UPS, Industrial Inverter.
- RoHS compliant.



SPECIFICATIONS

Item	Characteristics
Rated Voltage Range	350 ~ 550 V _{DC}
Operating Temperature Range	-25 ~ +85°C
Capacitance Tolerance	±20%(M) (at 20°C, 120Hz)
Leakage Current	I = 0.02CV or 5mA, whichever is smaller. Where, I: Leakage current (µA) C: Nominal capacitance (µF) V: Rated voltage (V _{DC}) (at 20°C, 5 minutes)
Dissipation Factor(Tanδ)	0.25max. (at 20°C, 120Hz)
Insulation Withstanding Voltage	When a voltage of 2,000V _{AC} is applied for one minute between the terminals shorted each other and the mounting clamp on the insulating sleeve covering the case, there shall not be electrical damage.
Load Life	The following specifications shall be satisfied when the capacitors are restored to 20°C after the rated voltage with the rated ripple current is applied (the peak voltage shall not exceed the rated voltage) for 5,000 hours at 85°C. Capacitance change ≤ ±30% of the initial value Tanδ ≤ 300% of the initial specified value Leakage current ≤ The initial specified value
Shelf Life	The following specifications shall be satisfied when the capacitors are restored to 20°C after the exposing them at 85°C for 500 hours without voltage applied. The rated voltage shall be applied to the capacitors for a minimum of 30 minutes, at least 24 hours and not more than 48 hours before measurements. Capacitance change ≤ ±20% of the initial value Tanδ ≤ 300% of the initial specified value Leakage current ≤ The initial specified value
Others	Satisfied characteristics KS C IEC 60384-4

RATED RIPPLE CURRENT MULTIPLIERS

Frequency Multiplying Factor

Frequency(Hz)	60	120	300	1k	3k
Factor	0.8	1.0	1.1	1.3	1.4

DIMENSIONS OF RFC(RWF) Series

Unit(mm)

Marking : BLACK SLEEVE, GOLD INK

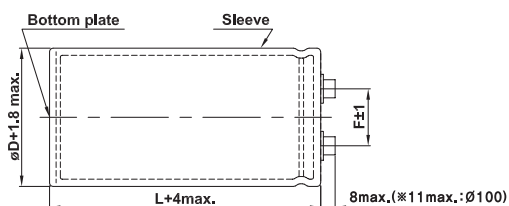

<Screw specifications>

øD = ø63 ~ ø89

● Plus hexagon-headed screw: M5×0.8×12

● Maximum screw tightening torque: 3.23N·m (33kg·cm)

øD = ø100

● Cross-recessed head (Phillips) screw: M8×1.25×16
Spring washer, Washer

● Maximum screw tightening torque: 6.31N·m(64kg·cm)

B type mounting clamp

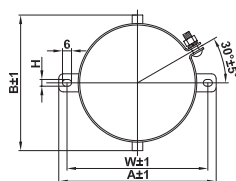

øD	A	B	W	H	F
63.5	90	75	80	4.5	28.0
76.5	104.5	90	93.5	4.5	31.5

C type mounting clamp

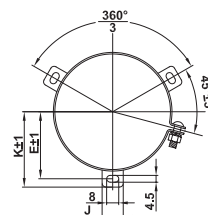

øD	E	K	J	F
63.5	38.1	43.5	14	28.0
76.5	44.5	50.0	14	31.5
89	50.8	56.5	16	31.5
100	56.5	63.4	18	41.5

RATINGS OF RFC(RWF) Series

VDC	Capacitance (μF)	∅D×L(mm)	Tanδ	Rated Ripple Current (Arms/85°C, 120Hz)	VDC	Capacitance (μF)	∅D×L(mm)	Tanδ	Rated Ripple Current (Arms/85°C, 120Hz)
350	3,900	63.5×120	0.25	12.1	500	1,500	63.5×90	0.25	6.3
	4,700	63.5×130	0.25	14.0		1,800	63.5×100	0.25	7.3
	5,600	63.5×160	0.25	16.6		2,200	63.5×120	0.25	8.4
	5,600	76.5×120	0.25	16.1		2,700	76.5×110	0.25	10.0
	6,800	63.5×190	0.25	20.0		3,300	76.5×130	0.25	11.3
	6,800	76.5×130	0.25	18.6		3,900	76.5×140	0.25	12.9
	8,200	76.5×160	0.25	22.2		4,700	76.5×150	0.25	14.3
	10,000	76.5×170	0.25	25.2		5,600	89×150	0.25	16.3
	12,000	89×160	0.25	29.1		6,800	89×170	0.25	19.2
	15,000	89×190	0.25	35.7		8,200	89×190	0.25	22.0
	18,000	100×220	0.25	44.2		12,000	100×220	0.25	30.2
	22,000	100×250	0.25	51.8		15,000	100×250	0.25	35.8
400	3,300	63.5×120	0.25	11.1	550	1,500	63.5×100	0.25	4.3
	3,900	63.5×130	0.25	12.7		1,800	63.5×120	0.25	5.3
	4,700	63.5×160	0.25	15.2		2,200	76.5×110	0.25	8.7
	4,700	76.5×120	0.25	14.7		2,700	76.5×130	0.25	9.3
	5,600	63.5×190	0.25	18.2		3,300	76.5×140	0.25	10.2
	5,600	76.5×130	0.25	16.9		3,900	76.5×150	0.25	11.3
	6,800	76.5×160	0.25	20.2		4,700	89×150	0.25	13.1
	8,200	76.5×170	0.25	22.8		5,600	89×170	0.25	15.2
	10,000	89×160	0.25	26.6		6,800	89×190	0.25	17.0
	12,000	89×170	0.25	30.0		8,200	100×220	0.25	21.3
	18,000	100×220	0.25	43.8		10,000	100×250	0.25	24.9
	22,000	100×250	0.25	51.3					
450	2,700	63.5×120	0.25	10.1					
	3,300	63.5×130	0.25	11.7					
	3,900	63.5×160	0.25	13.8					
	3,900	76.5×120	0.25	13.4					
	4,700	63.5×190	0.25	16.7					
	4,700	76.5×130	0.25	15.5					
	5,600	76.5×160	0.25	18.3					
	6,800	76.5×170	0.25	20.7					
	8,200	89×160	0.25	24.1					
	10,000	89×170	0.25	27.8					
	15,000	100×220	0.25	40.8					
	18,000	100×250	0.25	47.3					

RFA Series

- 85°C 20,000Hrs assured. (8,000Hrs for 550Vdc)

- Non-solvent proof.
- High Ripple Capability.
- Long Life.
- For Elevator, Industrial Inverter.
- RoHS compliant.



SPECIFICATIONS

Item	Characteristics
Rated Voltage Range	350 ~ 550 V _{DC}
Operating Temperature Range	-25 ~ +85°C
Capacitance Tolerance	±20% (M) (at 20°C, 120Hz)
Leakage Current	I = 0.02CV or 5mA, whichever is smaller. Where, I: Max. Leakage current (µA) C: Nominal capacitance (µF) V: Rated voltage (V _{DC}) (at 20°C, 5 minutes)
Dissipation Factor(Tanδ)	0.25max. (at 20°C, 120Hz)
Temperature Characteristics (Capacitance change ratio)	C(-25°C)/C(20°C) ≥ 0.7 (at 120Hz)
Insulation Withstanding Voltage	When a voltage of 2,000V _{AC} is applied for one minute between the terminals shorted each other and the mounting clamp on the insulating sleeve covering the case, there shall not be electrical damage.
Load Life	The following specifications shall be satisfied when the capacitors are restored to 20°C. after the rated voltage with the rated ripple current is applied (the peak voltage shall not exceed the rated voltage) for 20,000 hours 85°C. (8,000Hrs for 550 V _{DC}) Capacitance change ≤ ±30% of the initial value Tanδ ≤ 300% of the initial specified value Leakage current ≤ The initial specified value
Shelf Life	The following specifications shall be satisfied when the capacitors are restored to 20°C after the exposing them at 85°C for 500 hours without voltage applied. The rated voltage shall be applied to the capacitors for a minimum of 30 minutes, at least 24 hours and not more than 48 hours before the measurements. Capacitance change ≤ ±20% of the initial value Tanδ ≤ 300% of the initial specified value Leakage current ≤ The initial specified value
Others	Satisfied characteristics KS C IEC 60384-4

RATED RIPPLE CURRENT MULTIPLIERS

Frequency Multiplying Factor

Frequency(Hz)	60	120	300	1k	3k
Factor	0.8	1.0	1.1	1.3	1.4

DIMENSIONS OF RFA Series

Unit(mm)

Marking : BLACK SLEEVE, GOLD INK

B type mounting clamp

C type mounting clamp

<Screw specifications>

ø D = ø 63 ~ ø 89 ● Plus hexagon-headed screw: M5 × 0.8 × 12 ● Maximum screw tightening torque: 3.23N · m (33kg · cm)	ø D = ø 100 ● Cross-recessed head (Phillips) screw: M8 × 1.25 × 16 Spring washer, Washer ● Maximum screw tightening torque: 6.31N · m (64kg · cm)
---	--

ø D	A	B	W	H	F
63.5	90	75	80	4.5	28.0
76.5	104.5	90	93.5	4.5	31.5

ø D	E	K	J	F
63.5	38.1	43.5	14	28.0
76.5	44.5	50.0	14	31.5
89	50.8	56.5	16	31.5
100	56.5	63.4	18	41.5

RATINGS OF RFA Series

VDC	Capacitance (μF)	∅D×L(mm)	Tanδ	Rated Ripple Current (Arms/85°C, 120Hz)	VDC	Capacitance (μF)	∅D×L(mm)	Tanδ	Rated Ripple Current (Arms/85°C, 120Hz)	
350	3,300	63.5 × 120	0.25	11.1	500	1,200	63.5 × 90	0.25	5.3	
	3,900	63.5 × 130	0.25	12.8		1,500	63.5 × 100	0.25	6.3	
	4,700	63.5 × 160	0.25	15.2		1,800	63.5 × 120	0.25	7.4	
	4,700	76.5 × 120	0.25	14.7		2,200	76.5 × 110	0.25	9.0	
	5,600	63.5 × 170	0.25	17.3		2,700	76.5 × 130	0.25	10.3	
	5,600	76.5 × 130	0.25	16.9		3,300	76.5 × 140	0.25	11.9	
	6,800	63.5 × 190	0.25	20.0		3,900	76.5 × 150	0.25	13.3	
	6,800	76.5 × 160	0.25	20.2		4,700	89 × 150	0.25	15.3	
	8,200	76.5 × 170	0.25	23.1		5,600	89 × 170	0.25	18.2	
	10,000	89 × 160	0.25	26.6		6,800	89 × 190	0.25	21.0	
	12,000	89 × 190	0.25	32.0		10,000	100 × 220	0.25	29.0	
	18,000	100 × 220	0.25	44.7		12,000	100 × 250	0.25	33.7	
	22,000	100 × 250	0.25	52.3		550	1,000	63.5 × 120	0.25	4.7
	400	2,700	63.5 × 120	0.25			10.1	1,200	63.5 × 130	0.25
3,300		63.5 × 130	0.25	11.7	1,500		76.5 × 130	0.25	6.8	
3,900		63.5 × 160	0.25	13.5	2,200		89 × 130	0.25	9.4	
3,900		76.5 × 120	0.25	14.7	2,700		89 × 150	0.25	10.8	
4,700		63.5 × 170	0.25	15.8	3,300		89 × 170	0.25	12.6	
4,700		76.5 × 130	0.25	15.5	3,900		89 × 190	0.25	13.7	
5,600		63.5 × 190	0.25	18.2	4,700		89 × 220	0.25	15.1	
5,600		76.5 × 160	0.25	18.3	6,800		100 × 220	0.25	20.6	
6,800		76.5 × 170	0.25	21.0	8,200		100 × 250	0.25	24.9	
8,200		89 × 160	0.25	24.1	450		2,200	63.5 × 120	0.25	9.1
10,000		89 × 190	0.25	29.1			2,700	63.5 × 130	0.25	10.6
15,000		100 × 220	0.25	40.6			2,700	76.5 × 120	0.25	11.2
18,000		100 × 250	0.25	47.1			3,300	63.5 × 160	0.25	12.7
450		2,200	63.5 × 120	0.25		9.1	3,300	76.5 × 130	0.25	13.0
	2,700	63.5 × 130	0.25	10.6		3,900	63.5 × 170	0.25	14.4	
	2,700	76.5 × 120	0.25	11.2		4,700	76.5 × 160	0.25	16.7	
	3,300	63.5 × 160	0.25	12.7		5,600	76.5 × 170	0.25	21.1	
	3,300	76.5 × 130	0.25	13.0		5,600	89 × 160	0.25	19.9	
	3,900	63.5 × 170	0.25	14.4		6,800	89 × 170	0.25	23.0	
	4,700	76.5 × 160	0.25	16.7		8,200	89 × 190	0.25	26.4	
	5,600	76.5 × 170	0.25	21.1		12,000	100 × 220	0.25	36.3	
	5,600	89 × 160	0.25	19.9		15,000	100 × 250	0.25	42.9	
	6,800	89 × 170	0.25	23.0						
	8,200	89 × 190	0.25	26.4						
	12,000	100 × 220	0.25	36.3						
	15,000	100 × 250	0.25	42.9						

Note : When long life performance is required in actual use, the rms ripple current has to be reduced.

TFA Series

- 105°C 5,000Hrs assured, (2,000Hrs for 500~550V_{DC})

- Non-solvent proof.
- High Ripple Capability.
- Long Life.
- For Elevator, Industrial Inverter.
- RoHS compliant.



SPECIFICATIONS

Item	Characteristics
Rated Voltage Range	350 ~ 550 V _{DC}
Operating Temperature Range	-25 ~ +105°C
Capacitance Tolerance	±20% (M) (at 20°C, 120Hz)
Leakage Current	I = 0.02CV or 5mA, whichever is smaller. Where, I: Max. Leakage current (µA) C: Nominal capacitance (µF) V: Rated voltage (V _{DC}) (at 20°C, 5 minutes)
Dissipation Factor(Tanδ)	0.15max. (at 20°C, 120Hz)
Temperature Characteristics (Capacitance change ratio)	C(-25°C)/C(20°C) ≥ 0.7 (at 120Hz)
Insulation Withstanding Voltage	When a voltage of 2,000V _{AC} is applied for one minute between the terminals shorted each other and the mounting clamp on the insulating sleeve covering the case, there shall not be electrical damage.
Load Life	The following specifications shall be satisfied when the capacitors are restored to 20°C after their rated voltage with the rated ripple current is applied (the peak voltage shall not exceed the rated voltage) for 5,000 hours at 105°C. (2,000Hrs for 500~550V _{DC}) Capacitance change ≤ ±20% of the initial value Tanδ ≤ 200% of the initial specified value Leakage current ≤ The initial specified value
Shelf Life	The following specifications shall be satisfied when the capacitors are restored to 20°C after the exposing them at 105°C for 1,000 hours without voltage applied. The rated voltage shall be applied to the capacitors for a minimum of 30 minutes, at least 24 hours and not more than 48 hours before the measurements. Capacitance change ≤ ±20% of the initial value Tanδ ≤ 200% of the initial specified value Leakage current ≤ The initial specified value
Others	Satisfied characteristics KS C IEC 60384-4

RATED RIPPLE CURRENT MULTIPLIERS

Frequency Multiplying Factor

Frequency(Hz)	120	300	1k	3k
Factor	1.0	1.1	1.3	1.4

DIMENSIONS OF TFA Series

Unit(mm)

Marking : BROWN SLEEVE, SILVER INK

B type mounting clamp

∅D	A	B	W	H	F
63.5	90	75	80	4.5	28.0
76.5	104.5	90	93.5	4.5	31.5

C type mounting clamp

∅D	E	K	J	F
63.5	38.1	43.5	14	28.0
76.5	44.5	50.0	14	31.5
89	50.8	56.5	16	31.5
100	56.5	63.4	18	41.5

(Screw specifications)
 ∅D = ∅63 ~ ∅89 ∅D = ∅100
 • Plus hexagon-headed screw: M5×0.8×12 • Cross-recessed head (Phillips) screw: M8×1.25×16
 • Maximum screw tightening torque: 3.23N·m (33kg·cm) • Spring washer, Washer
 • Maximum screw tightening torque: 6.31N·m (64kg·cm)

RATINGS OF TFA Series

VDC	Capacitance (μF)	∅D×L(mm)	Tanδ	Rated Ripple Current (Arms/105°C, 120Hz)	VDC	Capacitance (μF)	∅D×L(mm)	Tanδ	Rated Ripple Current (Arms/105°C, 120Hz)
350	3,300	63.5×120	0.15	14.4	500	1,200	63.5×90	0.15	6.7
	3,900	63.5×130	0.15	16.6		1,500	63.5×100	0.15	7.8
	4,700	63.5×160	0.15	19.8		1,800	63.5×120	0.15	8.7
	4,700	76.5×120	0.15	19.1		2,200	76.5×110	0.15	9.9
	5,600	63.5×170	0.15	22.5		2,700	76.5×130	0.15	12.4
	5,600	76.5×130	0.15	21.9		3,300	76.5×140	0.15	13.9
	6,800	76.5×160	0.15	26.2		3,900	76.5×150	0.15	14.5
	8,200	76.5×170	0.15	30.0		4,700	89×150	0.15	15.8
	8,200	89×160	0.15	29.2		5,600	89×170	0.15	16.5
	10,000	89×170	0.15	33.7		6,800	89×190	0.15	18.8
	18,000	100×220	0.15	53.1		10,000	100×220	0.15	25.7
	22,000	100×250	0.15	62.2		12,000	100×250	0.15	29.9
	400	2,700	63.5×120	0.15		13.1	550	1,000	63.5×120
3,300		63.5×130	0.15	15.2	1,200	63.5×130		0.15	6.9
3,900		63.5×160	0.15	17.9	1,500	76.5×130		0.15	8.5
3,900		76.5×120	0.15	18.2	2,200	89×130		0.15	11.7
4,700		63.5×170	0.15	20.5	2,700	89×150		0.15	13.4
4,700		76.5×130	0.15	20.1	3,300	89×170		0.15	15.6
5,600		76.5×160	0.15	23.8	3,900	89×190		0.15	17.0
6,800		76.5×170	0.15	27.3	4,700	89×220		0.15	18.6
6,800		89×160	0.15	26.6	6,800	100×220		0.15	21.2
8,200		89×170	0.15	30.5	8,200	100×250		0.15	24.7
15,000		100×220	0.15	48.5					
18,000	100×250	0.15	56.2						
450	2,200	63.5×120	0.15	11.8					
	2,700	63.5×130	0.15	13.7					
	2,700	76.5×120	0.15	14.5					
	3,300	63.5×160	0.15	16.5					
	3,300	76.5×130	0.15	16.9					
	3,900	63.5×170	0.15	18.7					
	4,700	76.5×160	0.15	21.7					
	5,600	76.5×170	0.15	24.0					
	5,600	89×160	0.15	24.1					
	6,800	89×170	0.15	27.8					
	8,200	89×190	0.15	32.0					
	12,000	100×220	0.15	43.3					
	15,000	100×250	0.15	51.3					

Note : When long life performance is required in actual use, the rms ripple current has to be reduced.

PH Series

• 5~35°C 5,000Times.

- Non-solvent proof.
- For photo flash.
- RoHS compliant.



SPECIFICATIONS

Item	Characteristics				
Rated Voltage	330 V _{dc}				
Operating Temperature Range	-20 ~ +55°C				
Capacitance Tolerance	-10 ~ +20%(V) (at 20°C, 120Hz)				
Leakage Current	I = 1 × C Where, I: Leakage current (µA) C: Nominal capacitance (µF) (at 20°C, 5 minutes)				
Dissipation Factor(Tanδ)	<table border="1"> <tr> <td>Cap. ≤ 600µF</td> <td>0.10</td> </tr> <tr> <td>Cap. > 600µF</td> <td>0.15</td> </tr> </table> (at 20°C, 120Hz)	Cap. ≤ 600µF	0.10	Cap. > 600µF	0.15
Cap. ≤ 600µF	0.10				
Cap. > 600µF	0.15				
Charge and Discharge Characteristics	<p>The following specifications shall be satisfied when the capacitors are restored to 20°C after charge and discharge are repeated 5,000 times at room temperature. (5 to 35°C)</p> <p>Charge voltage: rated voltage Charge and discharge cycles:30 seconds Discharge resistance or Xenon tube:about 1 Ω</p> <p>Capacitance change ≤ ±10% of the initial value Tanδ ≤ 150% of the initial specified value Leakage current ≤ 150% of the initial specified value</p>				
Shelf Life	<p>The following specifications shall be satisfied when the capacitors are restored to 20°C after exposing them at 55°C for 1,000 hours without voltage applied.</p> <p>Capacitance change ≤ ±10% of the initial value Tanδ ≤ 150% of the initial specified value Leakage current ≤ 300% of the initial specified value</p>				
Others	Satisfied EIAJ RC-3801A				

RATINGS OF PH Series

µF	V _{dc} 330		V _{dc} 330	
	SV		SV	
165	16 × 27		500	25.4 × 54
180	14.5 × 35, 18 × 29		700	30 × 54
250	16 × 39		950	35 × 50
260	16 × 45		1,000	35 × 50
280	20 × 28		1,500	35 × 60
320	22 × 40		2,000	35 × 80
420	22 × 50			

↑
Case Size ØD×L(mm)

Note: Case sizes are changeable upon your requests.

DIMENSIONS

Unit(mm)

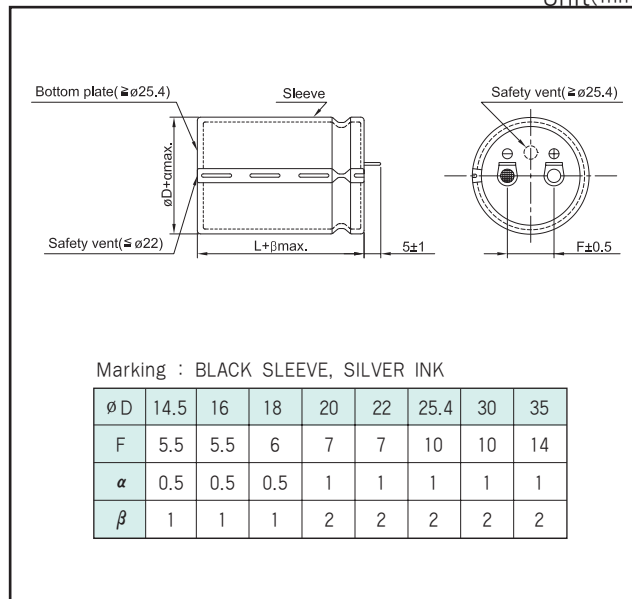

DH Series

• 40°C 1,000,000Times.

- Non-solvent proof.
- For Welding machine, Warning Light
- RoHS compliant.



SPECIFICATIONS

Item	Characteristics
Rated Voltage Range	315, 475 V _{DC}
Operating Temperature Range	-25 ~ +70°C
Capacitance Tolerance	-10 ~ +50%(T) (at 20°C, 120Hz)
Leakage Current	$I = 0.06CV$ or 3mA, whichever is smaller. Where, I:Max. Leakage current(µA) C:Nominal capacitance(µF) V:Rated voltage(V _{DC}) (at 20°C, 5 minutes)
Dissipation Factor(Tanδ)	0.10 Max. (at 20°C, 120Hz)
Temperature Characteristics (Capacitance change ratio)	$C(-10°C)/C(20°C) \geq 0.8$ (at 120Hz)
Load Life	The following specifications shall be satisfied when the capacitors are restored to 40°C after the rated working voltage applied. And then charge and discharge (charge 0.8sec. discharge 0.2sec) are repeated 1,000,000 times. And then the capacitors are restored to 20°C after the measurements. Capacitance change ≤ ±20% of the initial value Tanδ ≤ 200% of the initial specified value Leakage Current ≤ 200% of the initial specified value

RATINGS OF DH Series

µF \ V _{DC}	V _{DC}	
	315	475
100		35 × 110
150	35 × 100	
225		40 × 110
330	50 × 100	

↑
Case Size $\phi D \times L$ (mm)

*Case sizes are changeable upon your requests.

Note:When long life performance is required in actual use, the rms ripple current has to be reduced.

DIMENSIONS

Unit(mm)

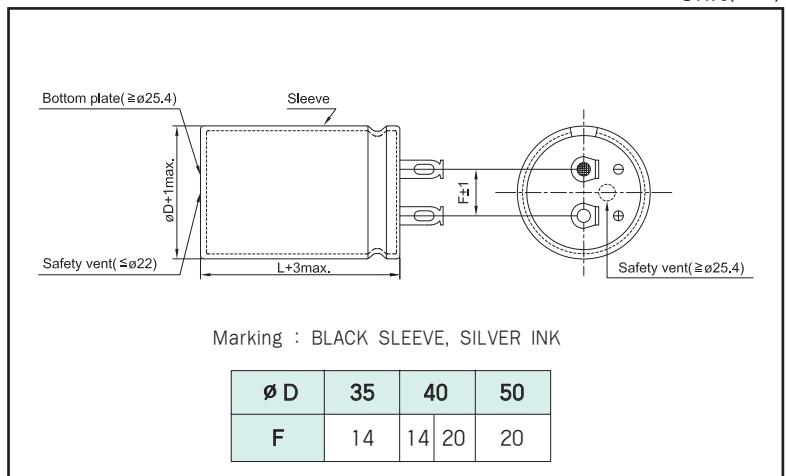

AVAILABLE TERMINALS

(mm)

D = ϕ 22to ϕ 40mm

Type : VN

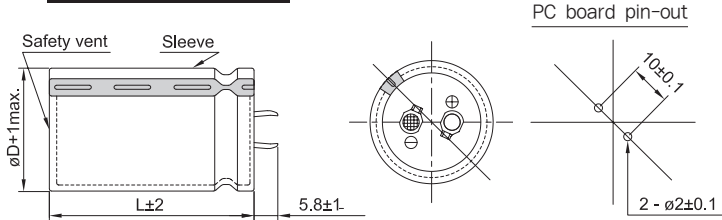

D = ϕ 22to ϕ 40mm

Type : VS

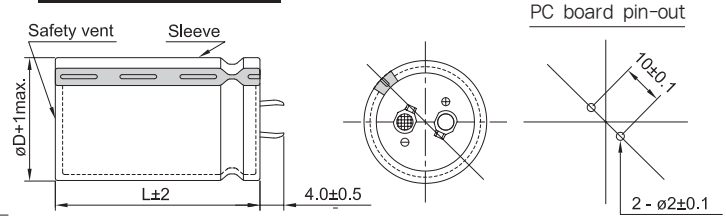

D = ϕ 35to ϕ 40mm

Type : VR (4 Terminals)

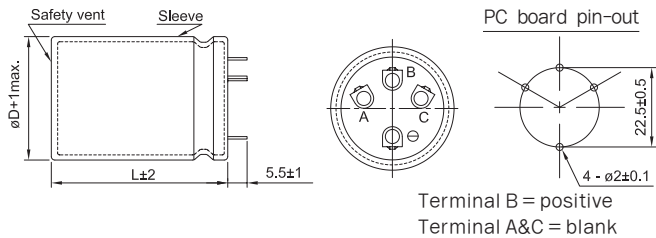

D = ϕ 35to ϕ 40mm

Type : VN4T (4 Terminals)

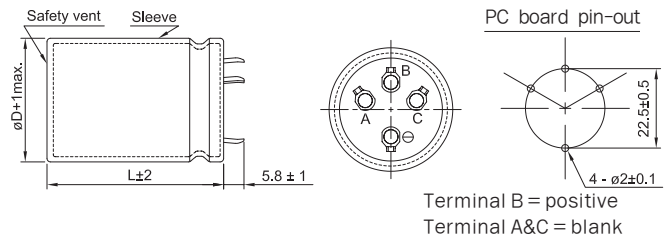

D = ϕ 35to ϕ 40mm

Type : LI

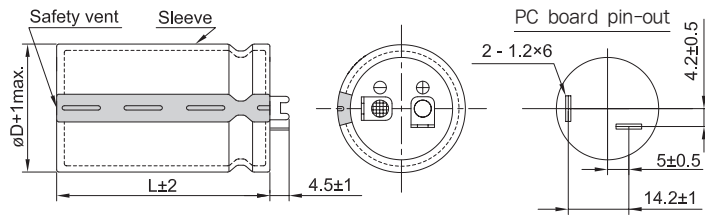

D = ϕ 22to ϕ 25.4mm

Type : VL

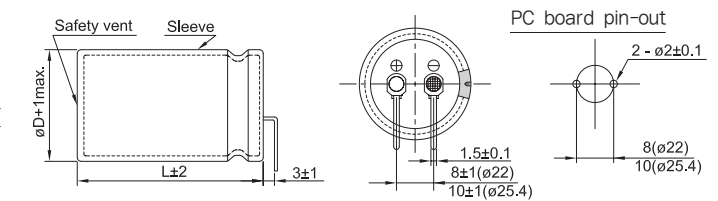

D = ϕ 35to ϕ 50mm

Type : LR

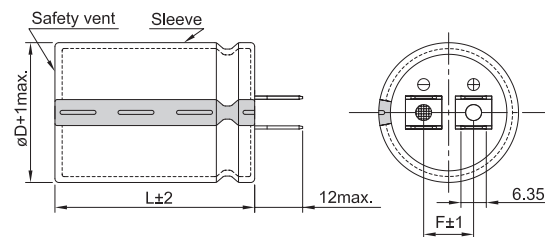

CAUTION

Use the blank terminals for mechanical support only.
The blank terminals must not be connected any copper on PC board.
Be sure to electrically isolate from negative or positive terminals.

ϕ D	35	40	50
F	12.5	14	



LARGE SIZED ALUMINUM ELECTROLYTIC CAPACITORS

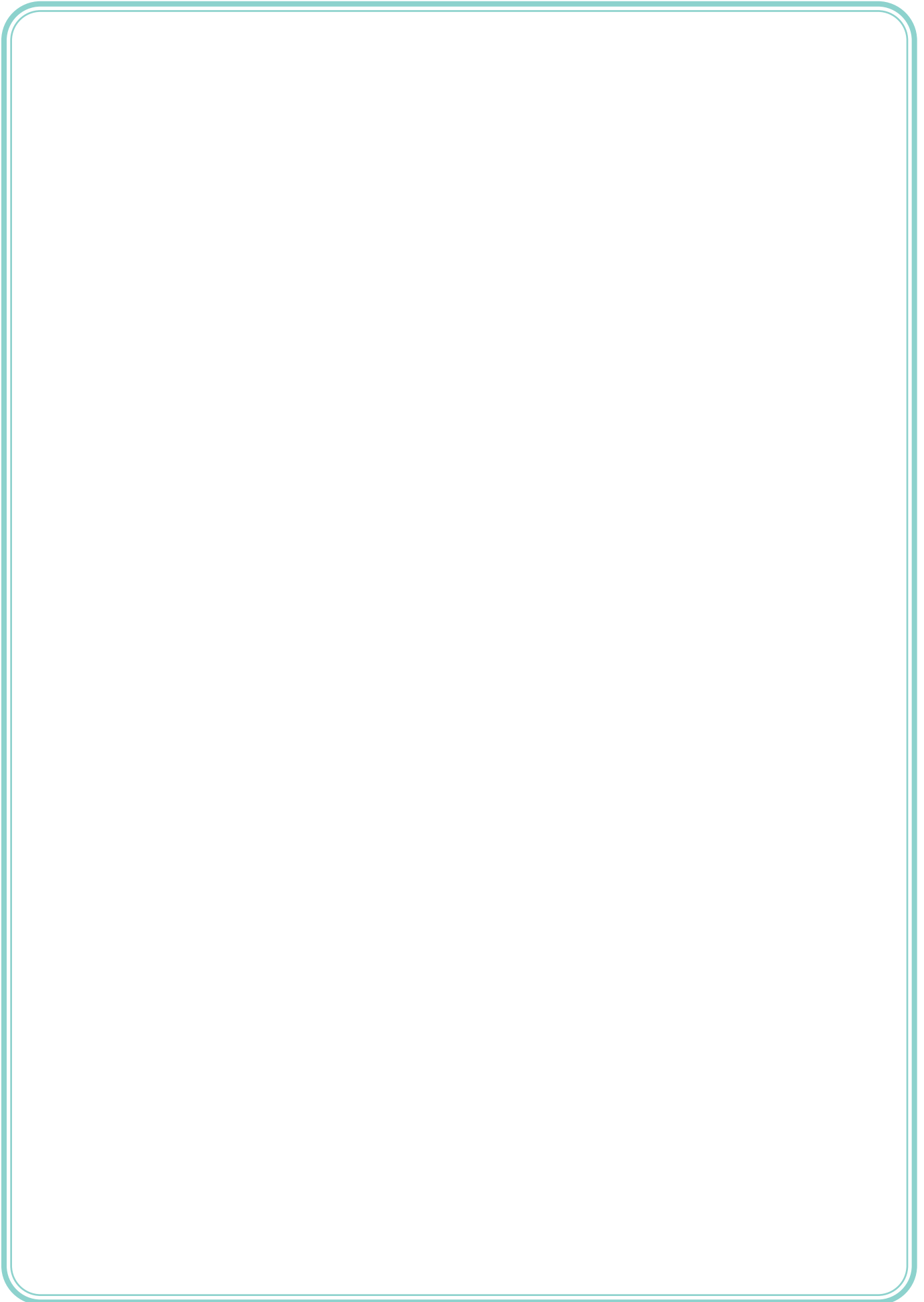



Sales Office

▶ OVERSEAS

OVERSEAS		ADDRESS	SALES	ENGINEERING	MARKETING		
SYHQs KOREA		47, Sagimakgol-ro, Jungwon-gu, Seongnam-si, Gyeonggi-do, 13209, Korea	e-Mail : ovs3@samyong.co.kr TEL : 82-31-740-2382 FAX : 82-31-741-3070				
SYHK HONG KONG		Samyoung Hong Kong Limited Room 1801, 18/F Pilkem Commercial Centre, 8 Pilkem Street, Jordan, Kowloon, Hong Kong	e-Mail : kbg@samyong.co.kr iris@samyong.com.hk TEL : 852-2377-0256/0270 FAX : 852-2377-1789				
QINGDAO SAMYOUNG	QINGDAO FACTORY	No.5 Chang Jiang Road, Ping Du City Shan Dong Province, China	e-Mail : guanbo@qsamyong.com TEL : 86-532-5865-7501 FAX : 86-532-5865-7011			e-Mail : pd19@samyong. co.kr TEL : 82-31-740-2220 FAX : 82-31-741-3070	e-Mail : ovs3@samyong. co.kr ovs11@samyong. co.kr ovs8@samyong. co.kr
	SHANGHAI BRANCH	Room 8C, 2016 YiShan Road, Shang Hai City, China	e-Mail : kyn@qsamyong.com TEL : 86-21-6242-1687 86-21-6242-2010 FAX : 86-21-6242-1103			TEL : 82-31-740-2382 82-31-740-2167 FAX : 82-31-741-3070	
	TIANJIN BRANCH	2-1910 Room, Jingcai Building, 459 Dagu South Street, Hexi District Tian Jin City, China	e-Mail : fym2008qd@qsamyong.com TEL : 86-22-8327-9979/9989 FAX : 86-22-8327-9989				
	SHENZHEN BRANCH	Room 17H, Building A Zhongzhishidai Plaza, Donghuan 2Road, Longhua District Shenzhen City, China	e-Mail : ww128@qsamyong.com TEL : 86-755-3307-0988 FAX : 86-755-3307-0989				



▶ LOCAL

DOMESTICS	ADDRESS	SALES	ENGINEERING
SALES SPEC 1	47, Sagimakgol-ro, Jungwon-gu, Seongnam-si, Gyeonggi-do, 13209, Korea	e-Mail : pd30@samyong.co.kr TEL : 82-31-740-2267 FAX : 82-31-741-3070	e-Mail : pd19@samyong.co.kr TEL : 82-31-740-2220 FAX : 82-31-741-3070
SALES SPEC 2		e-Mail : mk17@samyong.co.kr TEL : 82-31-740-2217 FAX : 82-31-741-3070	



SamYoung Electronics Co.,Ltd.

13209

HEAD OFFICE & FACTORY : 47, Sagimakgol-ro, Jungwon-gu,
Seongnam-si, Gyeonggi-do, KOREA

TELEPHONE : (031)743-6701~10, 740-2114

FAX : (031)741-3077, 3070

MARKETING SECTION : (031)741-3073~5

http : //www.samyoungh.co.kr



CAUTION FOR SAFETY

- Always read 「Notes on Use」 before using the product in order to enable you to use the product correctly and prevent any faults and accidents from occurring.
- Request the 「Deliverly Specification」 on the product of SAMYOUNG ELECTRONICS CORPORATION to refer to it as well as this brochure prior to the order of the products. Some specific notes on use of the ordered product may be described in the specifications.