

Technical Data Sheet

Side View LEDs (Height 0.6mm)

99-616LM2C/L6570S76/TR8-T

Features

- Side view white LED
- White SMT package
- Lead frame package with individual 2 pins
- Wide viewing angle
- Soldering methods: IR reflow soldering
- Pb-free
- The product itself will remain within RoHS compliant version.



Descriptions

- Due to the package design, 99-616 has wide viewing angle, low power consumption and white LEDs are devices which are materialized by combing blue chip and special phosphor. This feature makes the LED ideal for light guide application.

Applications

- LCD Back Light
- Mobile phones
- Indicators
- Illuminations
- Switch Lights

Device Selection Guide

Chip	Emitted Color	Resin Color
Material		
InGaN	Pure White	Water Clear

Technical Data Sheet

Side View LEDs (Height 0.6mm)

99-616LM2C/L6570S76/TR8-T

Package Outline Dimensions

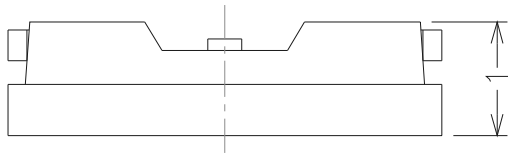

Polarity

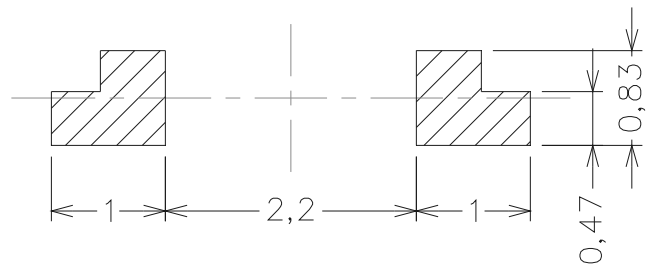
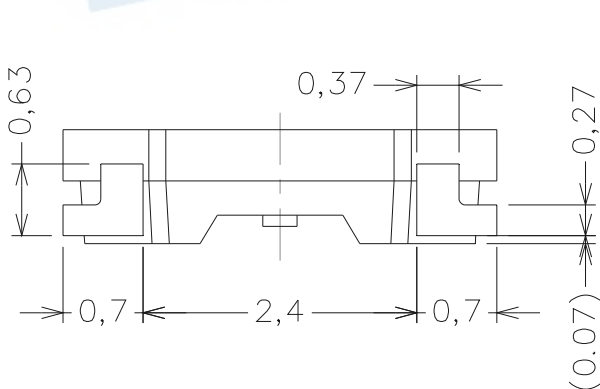
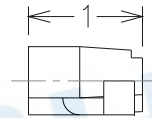
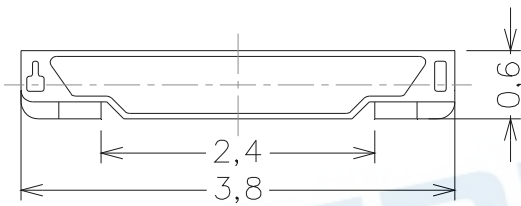

Recommended soldering pad design

Note: The tolerances unless mentioned are ± 0.1 mm, unit = mm.

Technical Data Sheet

Side View LEDs (Height 0.6mm)

99-616LM2C/L6570S76/TR8-T

Absolute Maximum Ratings (Ta=25°C)

Parameter	Symbol	Rating	Unit
Reverse Voltage	V _R	5	V
Forward Current	I _F	30	mA
Peak Forward Current (Duty 1/10 @10ms)	I _{FP}	100	mA
Power Dissipation	P _d	110	mW
Electrostatic Discharge(HBM)* ¹	ESD	2000	V
Operating Temperature	T _{opr}	-40 ~ +85	°C
Storage Temperature	T _{stg}	-40 ~ +90	°C
Soldering Temperature	T _{sol}	Reflow Soldering: 260 °C for 10 sec. Hand Soldering: 350 °C for 3 sec.	

Note: The products are sensitive to static electricity and must be carefully taken when handling products.

Electro-Optical Characteristics (Ta=25°C)

Parameter	Symbol	Min.	Typ.	Max.	Unit	Condition
Luminous Flux	Φ	6.50	-----	7.25	lm	I _F =20mA
Viewing Angle	2θ _{1/2}	-----	115	-----	deg	
Forward Voltage	V _F	2.95	-----	3.45	volt	
Reverse Current	I _R	-----	-----	50	μA	V _R =5V

Notes:

1. Tolerance of Luminous Flux: ±7%
2. Tolerance of Forward Voltage: ±0.05V

Technical Data Sheet

Side View LEDs (Height 0.6mm)

99-616LM2C/L6570S76/TR8-T

Bin Range of Luminous Flux

Bin Code	Lm		Condition	Mcd	
	Min.	Max.		Min.	Max.
65	6.50	6.75	I _F =20mA	2321	2411
67	6.75	7.00		2411	2500
70	7.00	7.25		2500	2589

Note: Measurement Tolerance of Luminous Flux: $\pm 7\%$

Bin Range of Forward Voltage

Bin Code	Min.	Max.	Unit	Condition
6-1	2.95	3.05	volt	I _F =20mA
6-2	3.05	3.15		
7-1	3.15	3.25		
7-2	3.25	3.35		
8-1	3.35	3.45		

Note: Tolerance of Forward Voltage: $\pm 0.05V$

Technical Data Sheet

Side View LEDs (Height 0.6mm)

99-616LM2C/L6570S76/TR8-T

Bin Code of Chromaticity Coordinates

Bin Code	CIE_x	CIE_y	Bin Code	CIE_x	CIE_y
NA0-3-1	0.2760	0.2530	NA0-3-2	0.2805	0.2600
	0.2720	0.2580		0.2770	0.2650
	0.2770	0.2650		0.2820	0.2720
	0.2805	0.2600		0.2850	0.2670
NA0-3-3	0.2800	0.2480	NA0-3-4	0.2840	0.2550
	0.2760	0.2530		0.2805	0.2600
	0.2805	0.2600		0.2850	0.2670
	0.2840	0.2550		0.2880	0.2620
NA0-4-1	0.2850	0.2670	NA0-4-2	0.2893	0.2743
	0.2820	0.2720		0.2865	0.2795
	0.2865	0.2795		0.2910	0.2870
	0.2893	0.2743		0.2935	0.2815
NA0-4-3	0.2880	0.2620	NA0-4-4	0.2920	0.2690
	0.2850	0.2670		0.2893	0.2743
	0.2893	0.2743		0.2935	0.2815
	0.2920	0.2690		0.2960	0.2760

Note: Tolerance of Chromaticity Coordinates: ± 0.01

Technical Data Sheet Side View LEDs (Height 0.6mm)

99-616LM2C/L6570S76/TR8-T

The C.I.E. 1931 Chromaticity Diagram

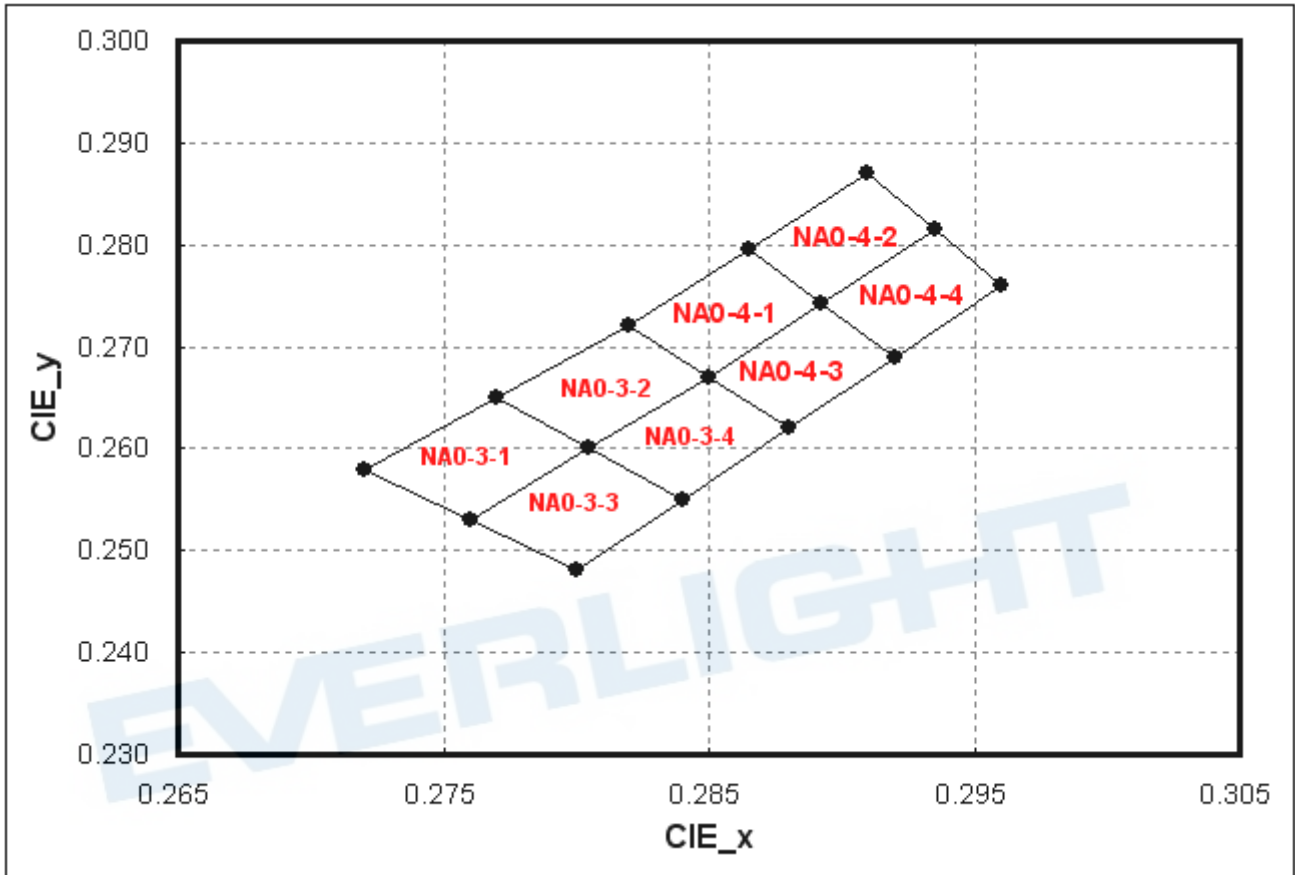

Technical Data Sheet

Side View LEDs (Height 0.6mm)

99-616LM2C/L6570S76/TR8-T

Typical Electro-Optical Characteristics Curves

1. Spectrum Distribution

($T_S=25^\circ\text{C}$, $I_F=20\text{mA}$)

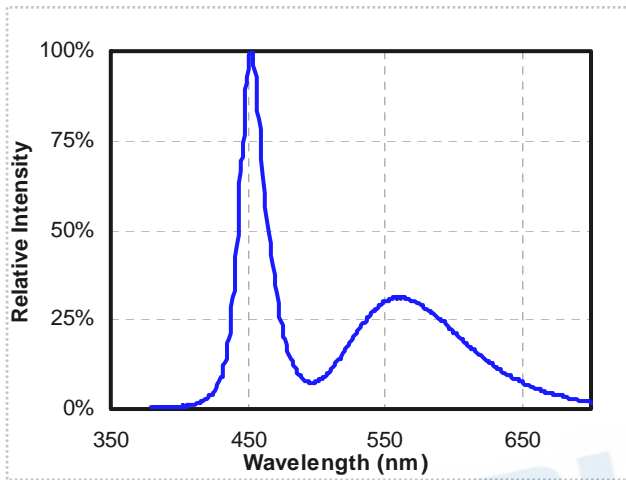

2. Relative Luminous Flux vs. Forward Current

($T_S=25^\circ\text{C}$)

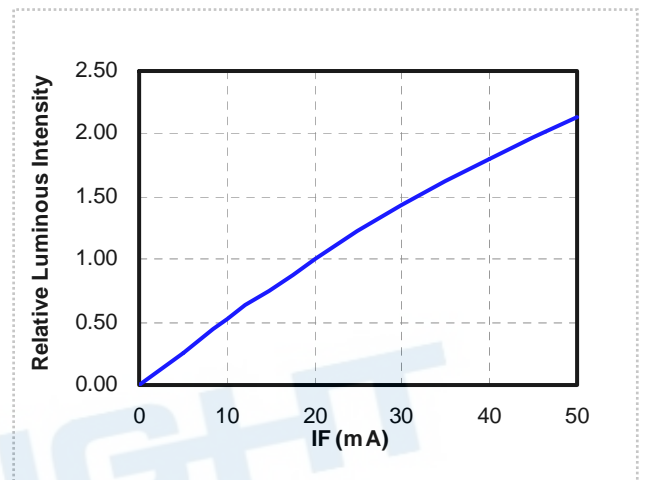

3. Relative Forward Voltage vs. Forward Current

($T_S=25^\circ\text{C}$)

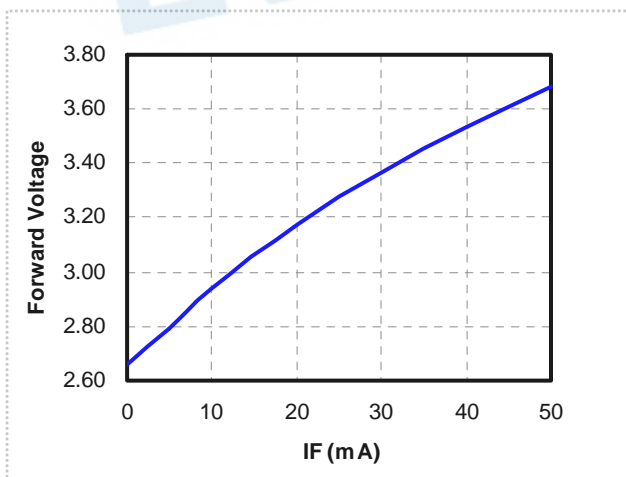

4. Radiation Diagram

($T_S=25^\circ\text{C}$, $I_F=20\text{mA}$)

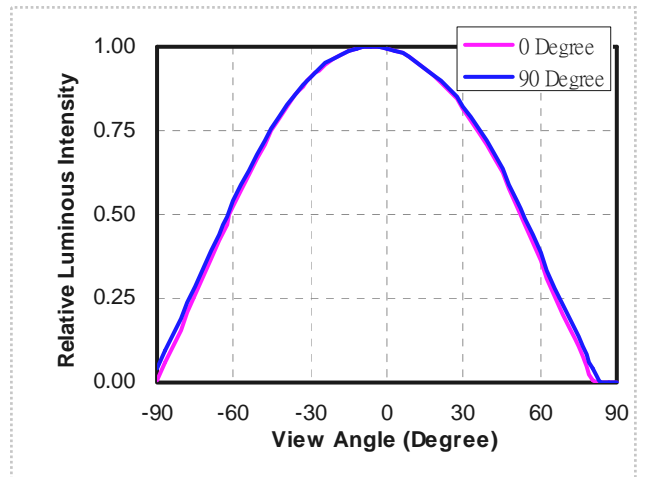

Technical Data Sheet

Side View LEDs (Height 0.6mm)

99-616LM2C/L6570S76/TR8-T

Typical Electro-Optical-Thermal Characteristics Curves

5. Relative Luminous Flux vs. Ambient Temperature
($I_f=20\text{mA}$)

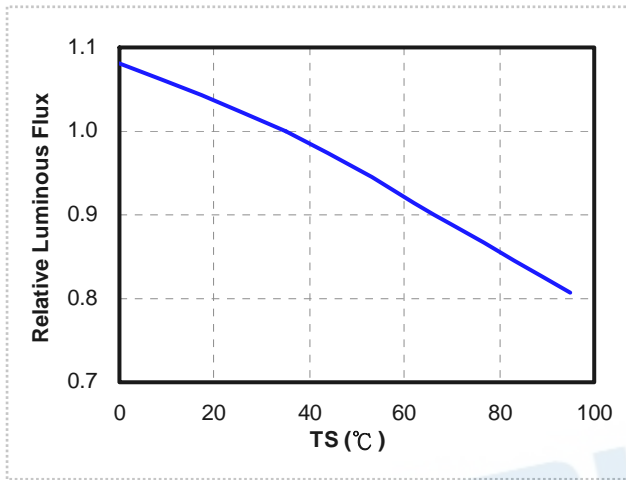

6. Forward Voltage vs. Ambient Temperature
($I_f=20\text{mA}$)

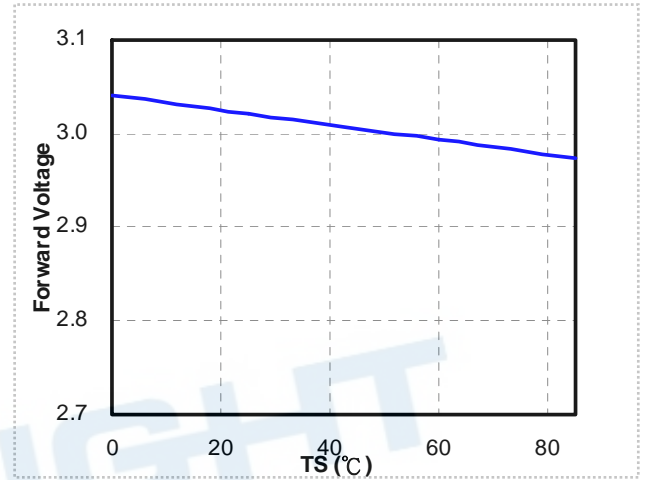

7. Chromaticity Coordinates vs. Ambient Temperature
($I_f=20\text{mA}$)

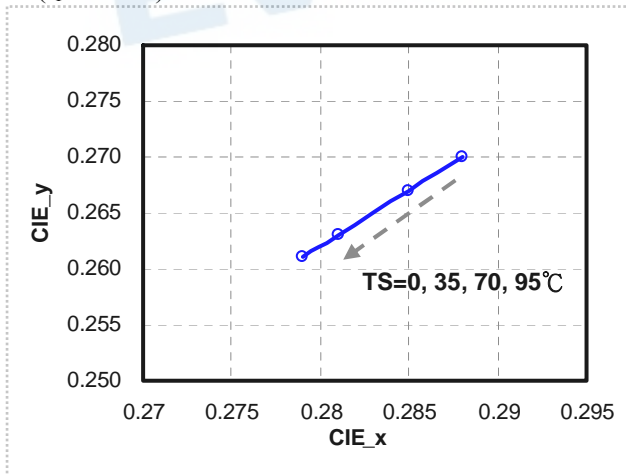

8. Forward Current De-rating Curve

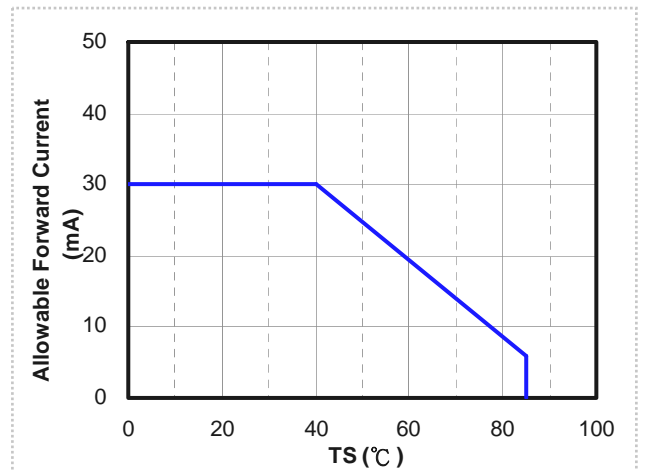

Technical Data Sheet

Side View LEDs (Height 0.6mm)

99-616LM2C/L6570S76/TR8-T

Label Explanation

CAT: Luminous Flux Rank
 HUE: Chromaticity Coordinates
 REF: Forward Voltage Rank



Reel Dimensions

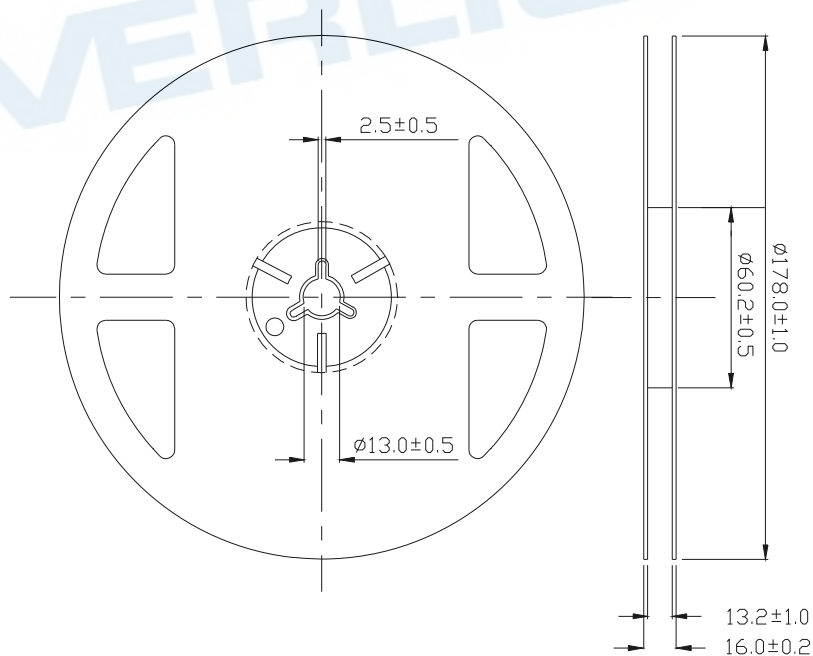

Note: The tolerance unless mentioned is ± 0.1 mm, unit = mm.

Technical Data Sheet

Side View LEDs (Height 0.6mm)

99-616LM2C/L6570S76/TR8-T

Carrier Tape Dimensions: Loaded Quantity 250 up/500/1000/2000 pcs. Per Reel

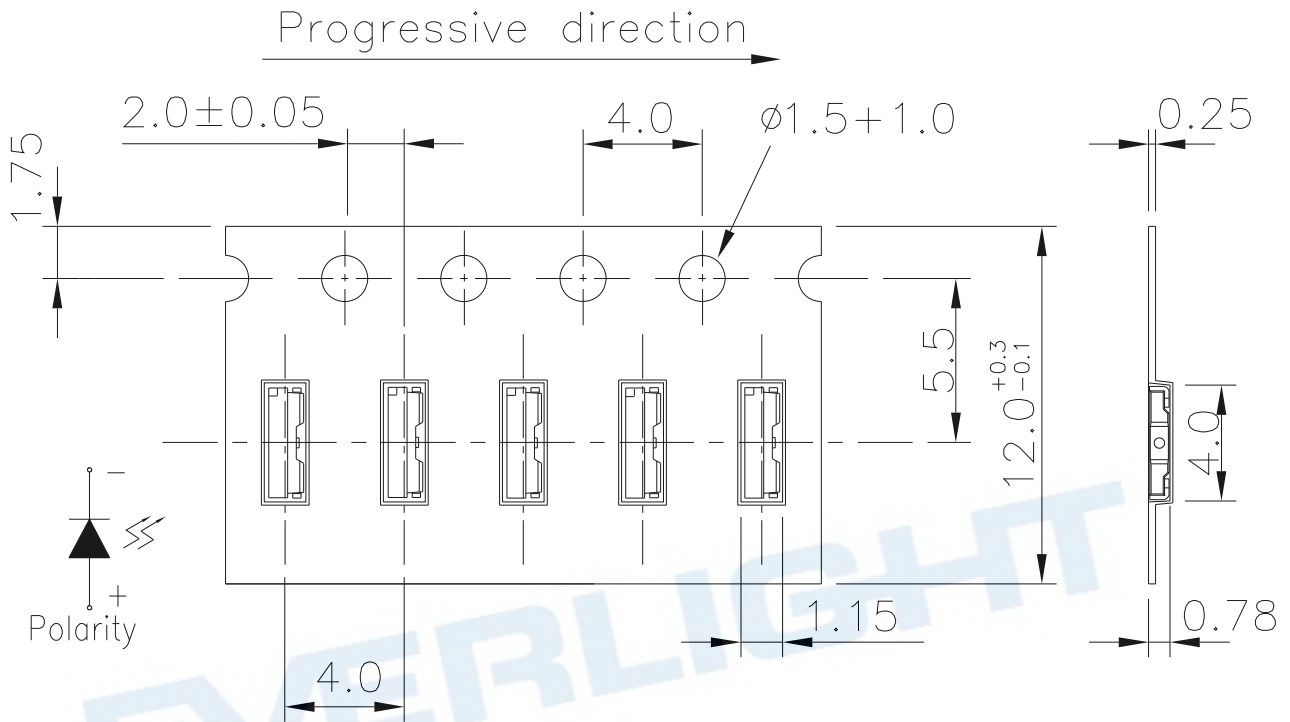

Note: The tolerance unless mentioned is ± 0.1 mm, unit = mm.

Moisture Resistant Packaging

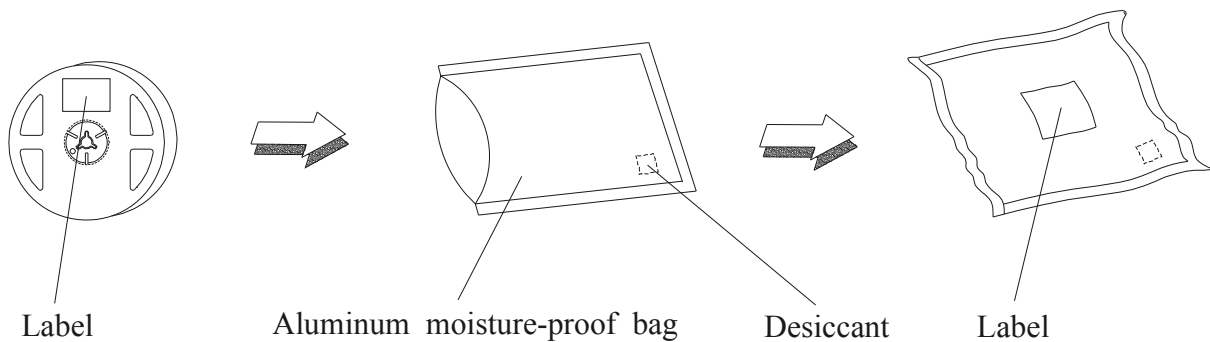

Technical Data Sheet

Side View LEDs (Height 0.6mm)

99-616LM2C/L6570S76/TR8-T

Reliability Test Items and Conditions

The reliability of products shall be satisfied with items listed below.

Confidence level : 90%

LTPD : 10%

NO	Item	Test Condition		Test Hours / Times	Criteria	
		Temp./ Humidity	I _F (mA)		I _v @ 20mA	V _F @ 20mA
1	Reflow Soldering	T _{Sld} = 260°C, Max. 10sec.		2 times	<±10%	<±10%
2	Thermal Cycle	-40°C ~ 100°C 30min. (5min.) 30min.		200 cycles	I _v > 70%, V _F < 110%,	
3	Thermal Shock	-10°C ~ 100°C 20min. (<15sec.) 20min.		200 cycles		
4	Low Temp. Storage	T _a = -40°C	--	1000 hrs		
5	High Temp. Storage	T _a = 100°C	--	1000 hrs		
6	Temp. Humidity Storage	T _a = 60°C / 90%RH	--	1000 hrs		
7	Steady State Operating Life of Low Temp.	T _a = -40°C	20	1000 hrs		
8	Steady State Operating Life Condition 1	T _a = 25°C / Room Humidity	20	1000 hrs		
9	Steady State Operating Life Condition 2	T _a = 60°C	20	1000 hrs		
10	Steady State Operating Life of High Temp.	T _a = 85°C	5	1000 hrs		
11	Steady State Operating Life of High Humidity Heat	T _a = 60°C / 90%RH	20	1000 hrs		

Technical Data Sheet

Side View LEDs (Height 0.6mm)

99-616LM2C/L6570S76/TR8-T

Precautions for Use

1. Over-current-proof

Customer must apply resistors for protection, otherwise slight voltage shift will cause big current change (Burn out will happen).

2. Storage

2.1 Do not open moisture proof bag before the products are ready to use.

2.2 Before opening the package: The LEDs should be kept at 30°C or less and 90%RH or less.

2.3 After opening the package: The LED's floor life is 1 year under 30°C or less and 60% RH or less.

If unused LEDs remain, it should be stored in moisture proof packages.

2.4 If the moisture absorbent material (silica gel) has faded away or the LEDs have exceeded the storage time, baking treatment should be performed using the following conditions.

Baking treatment : 60±5°C for 24 hours.

3. Soldering Condition

3.1 Pb-free solder temperature profile

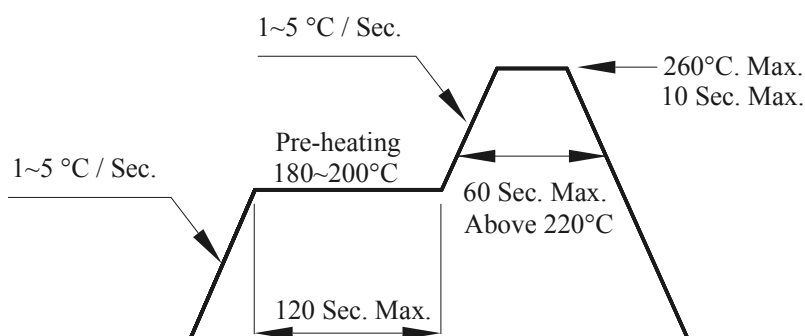

3.2 Reflow soldering should not be done more than two times.

3.3 When soldering, do not put stress on the LEDs during heating.

3.4 After soldering, do not warp the circuit board.

Technical Data Sheet

Side View LEDs (Height 0.6mm)

99-616LM2C/L6570S76/TR8-T

4. Soldering Iron

Each terminal is to go to the tip of soldering iron temperature less than 350°C for 3 seconds within once in less than the soldering iron capacity 25W. Leave two seconds and more intervals, and do soldering of each terminal. Be careful because the damage of the product is often started at the time of the hand solder.

5. Repairing

Repair should not be done after the LEDs have been soldered. When repairing is unavoidable, a double-head soldering iron should be used (as below figure). It should be confirmed beforehand whether the characteristics of the LEDs will or will not be damaged by repairing.

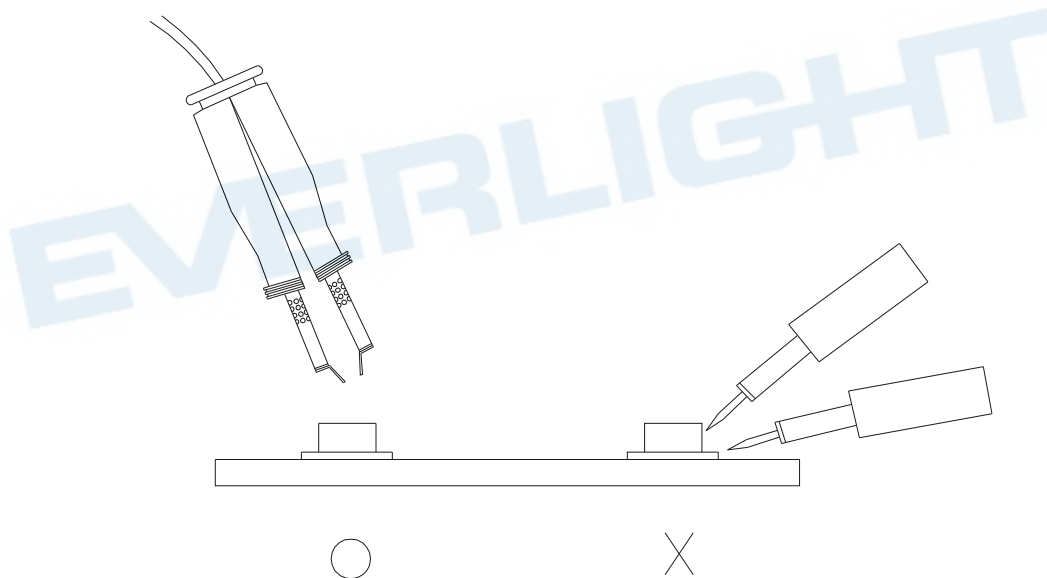

6. Handling Indications

During processing, mechanical stress on the surface should be minimized as much as possible. Sharp objects of all types should not be used to pierce the sealing compound

EVERLIGHT ELECTRONICS CO., LTD.
Office: No 25, Lane 76, Sec 3, Chung Yang Rd,
Tucheng, Taipei 236, Taiwan, R.O.C

Tel: 886-2-2267-2000, 2267-9936
Fax: 886-2267-6244, 2267-6189, 2267-6306
<http://www.everlight.com>