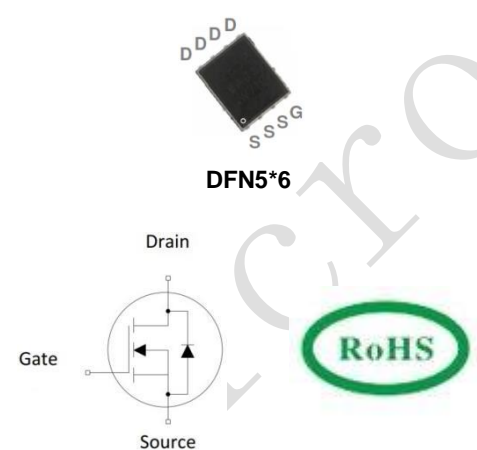

N-channel 100V, 70A, 7mΩ SGT MOSFET

<p>Description</p> <p>This power MOSFET is designed with split gate trench technology. The resulting device has extremely low on resistance, making it especially suitable for applications which require superior power density and outstanding efficiency.</p> <p>Features</p> <ul style="list-style-type: none"> ◆ Very low FOM $R_{DS(on)} \times Q_g$ ◆ 100% UIS tested ◆ RoHS compliant <p>Applications</p> <ul style="list-style-type: none"> ◆ Motor Drivers. ◆ DC-DC Converter. ◆ Uninterrupted power supply (UPS). 	<p>Product Summary</p> <table style="width: 100%; border: none;"> <tr> <td style="padding: 2px 5px;">$V_{DS} @ T_{j,25^\circ C}$</td> <td style="padding: 2px 5px;">100V</td> </tr> <tr> <td style="padding: 2px 5px;">$R_{DS(on),max}$</td> <td style="padding: 2px 5px;">7mΩ</td> </tr> <tr> <td style="padding: 2px 5px;">I_D</td> <td style="padding: 2px 5px;">70A</td> </tr> </table> <div style="text-align: center; margin-top: 10px;">  <p>DFN5*6</p> <p>Drain</p> <p>Gate</p> <p>Source</p> <p>RoHS</p> <p>N-Channel MOSFET</p> </div>	$V_{DS} @ T_{j,25^\circ C}$	100V	$R_{DS(on),max}$	7mΩ	I_D	70A
$V_{DS} @ T_{j,25^\circ C}$	100V						
$R_{DS(on),max}$	7mΩ						
I_D	70A						

Absolute Maximum Ratings

Parameter	Symbol	Value	Unit
Drain-Source Voltage	V_{DSS}	100	V
Continuous drain current ($T_C = 25^\circ C$)	I_D	70	A
($T_C = 100^\circ C$)		44	A
Pulsed drain current ¹⁾	I_{DM}	280	A
Gate-Source voltage	V_{GSS}	± 20	V
Avalanche energy, single pulse ²⁾	E_{AS}	200	mJ
Power Dissipation DFN5*6 ($T_C = 25^\circ C$)	P_D	102	W
- Derate above 25°C		0.82	W/°C
Operating and Storage Temperature Range	T_J, T_{STG}	-55 to +150	°C
Continuous diode forward current	I_S	70	A
Diode pulse current	$I_{S,pulse}$	280	A

Thermal Characteristics DFN5*6

Parameter	Symbol	Value	Unit
Thermal Resistance, Junction-to-Case	$R_{\theta JC}$	0.73	$^{\circ}C/W$
Thermal Resistance, Junction-to-Ambient	$R_{\theta JA}$	49	$^{\circ}C/W$
Soldering temperature, wave soldering only allowed at leads. (1.6mm from case for 10s)	T_{sold}	260	$^{\circ}C$

Electrical Characteristics $T_c = 25^{\circ}C$ unless otherwise noted

Parameter	Symbol	Test Condition	Min.	Typ.	Max.	Unit
Static characteristics						
Drain-source breakdown voltage	BV_{DSS}	$V_{GS}=0V, I_D=250\mu A$	100	-	-	V
Gate threshold voltage	$V_{GS(th)}$	$V_{DS}=V_{GS}, I_D=250\mu A$	1		3	V
Drain cut-off current	I_{DSS}	$V_{DS}=100V, V_{GS}=0V,$ $T_j = 25^{\circ}C$ $T_j = 125^{\circ}C$	-	-	1	μA
			-	10	-	
Gate leakage current, Forward	I_{GSSF}	$V_{GS}=20V, V_{DS}=0V$	-	-	100	nA
Gate leakage current, Reverse	I_{GSSR}	$V_{GS}=-20V, V_{DS}=0V$	-	-	-100	nA
Drain-source on-state resistance	$R_{DS(on)}$	$V_{GS}=10V, I_D=35A$ $T_j = 25^{\circ}C$	-	7	8.6	m Ω
			-		-	
Dynamic characteristics						
Input capacitance	C_{iss}	$V_{DS} = 50V, V_{GS} = 0V,$	-	3041	-	pF
Output capacitance	C_{oss}	$f = 1MHz$	-	486	-	
Reverse transfer capacitance	C_{rss}		-	12	-	
Turn-on delay time	$t_{d(on)}$	$V_{DD} = 50V, I_D = 35A$	-	16	-	ns
Rise time	t_r	$R_G = 25\Omega, V_{GS}=10V$	-	50	-	
Turn-off delay time	$t_{d(off)}$		-	135	-	
Fall time	t_f		-	90	-	
Gate charge characteristics						
Gate to source charge	Q_{gs}	$V_{DD}=80V, I_D=35A,$	-	8.6	-	nC
Gate to drain charge	Q_{gd}	$V_{GS}=0$ to 10 V	-	9.1	-	
Gate charge total	Q_g		-	42	-	
Gate plateau voltage	$V_{plateau}$		-	2.5	-	V
Reverse diode characteristics						
Diode forward voltage	V_{SD}	$V_{GS}=0V, I_F=35A$	-	0.85	-	V
Reverse recovery time	t_{rr}	$V_R=50V, I_F=35A,$	-	72	-	ns
Reverse recovery charge	Q_{rr}	$dI_F/dt=100A/\mu s$	-	110	-	nC

Notes:

- Limited by maximum junction temperature, maximum duty cycle is 0.75.
- $I_{AS} = 20A, V_{DD} = 50V,$ Starting $T_j = 25^{\circ}C$.
- Repetitive Rating: Pulse width limited by maximum junction temperature.

Electrical Characteristics Diagrams

Figure 1. Output Characteristics

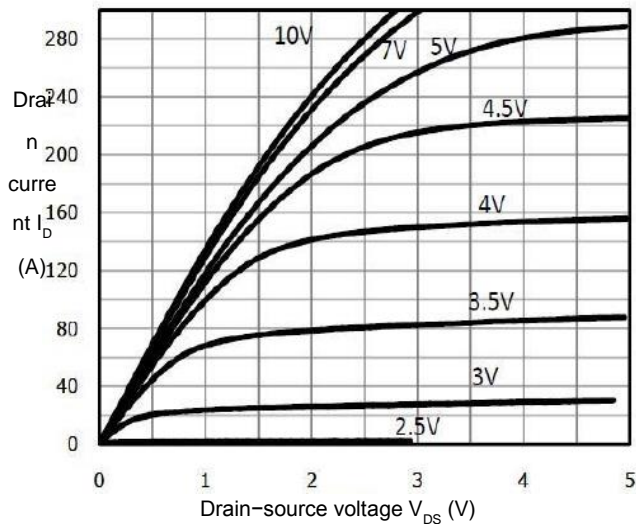

Figure 2. Transfer Characteristics

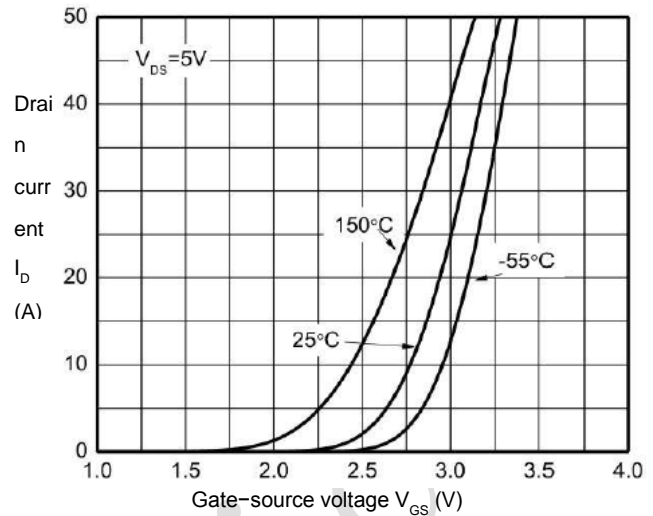

Figure 3. On-Resistance vs. Drain Current

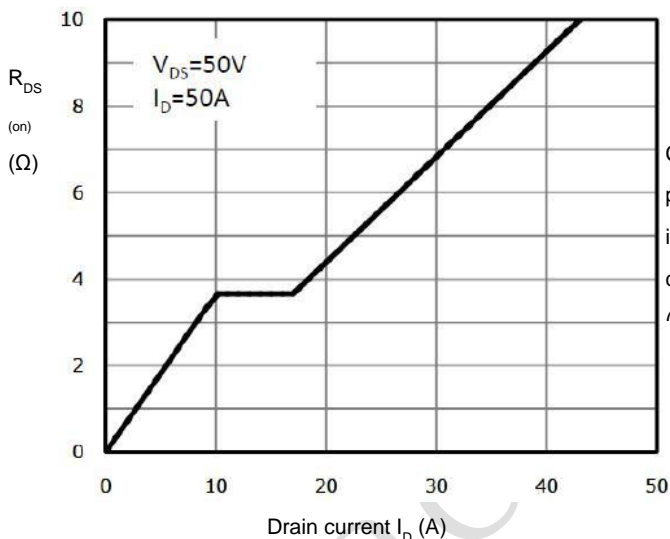

Figure 4. Capacitance Characteristics

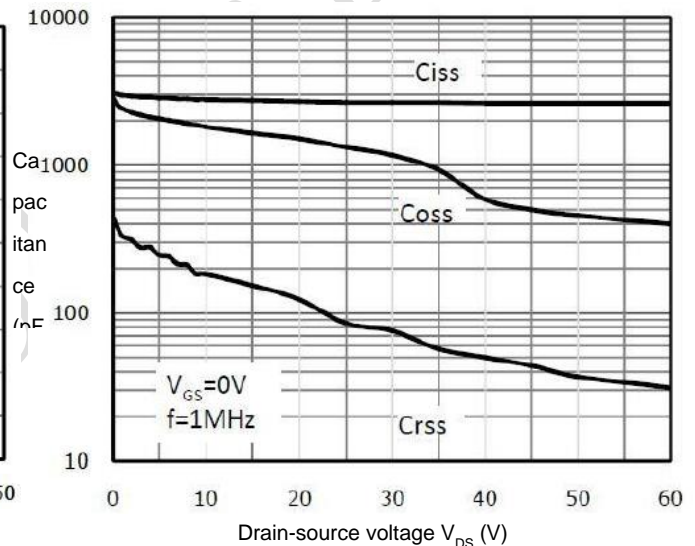

Figure 5. Gate Charge Characteristics

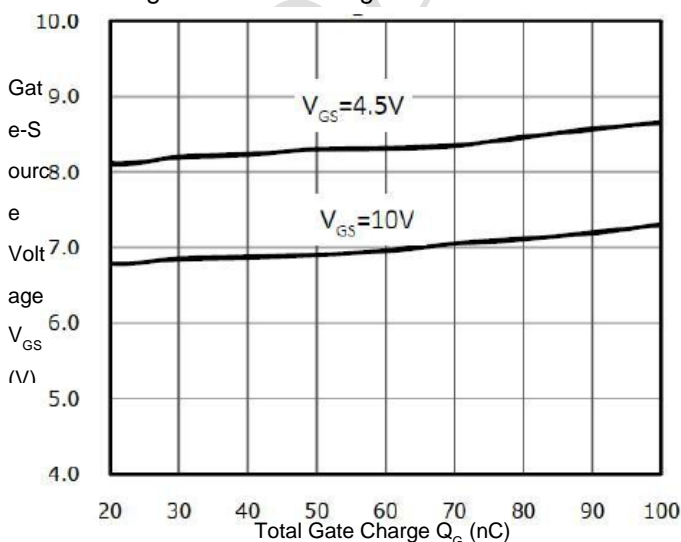

Figure 6. Body Diode Forward Voltage

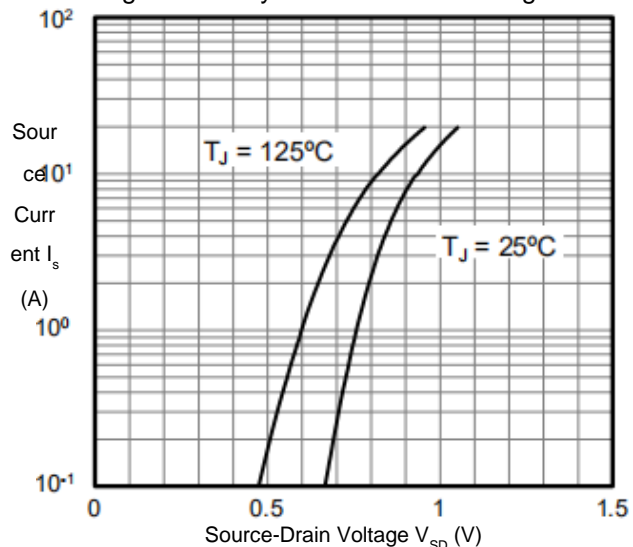

Figure 7. Breakdown Voltage vs. Temperature

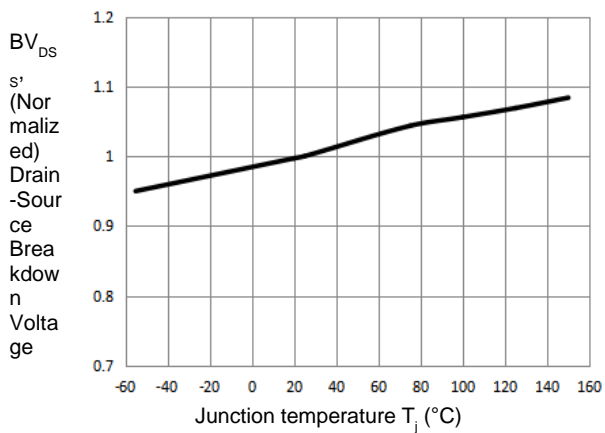

Figure 8. On-Resistance vs. Temperature

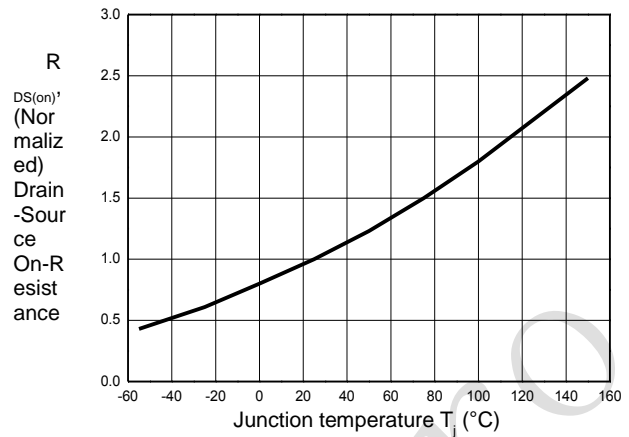

Figure 9. Transient Thermal Impedance

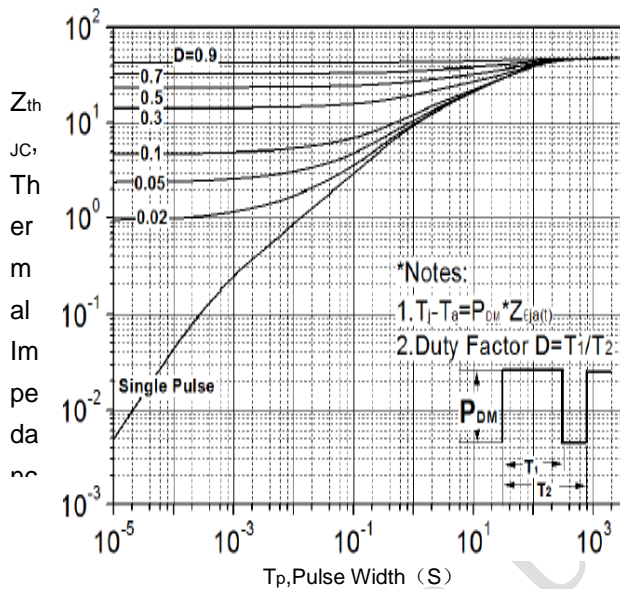
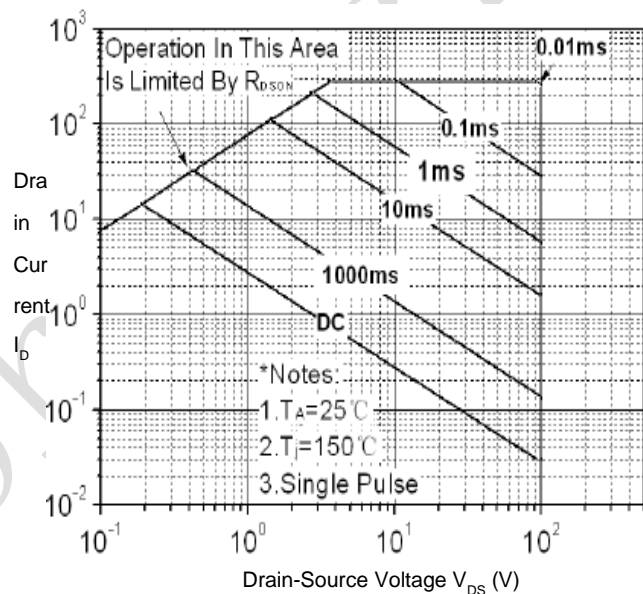
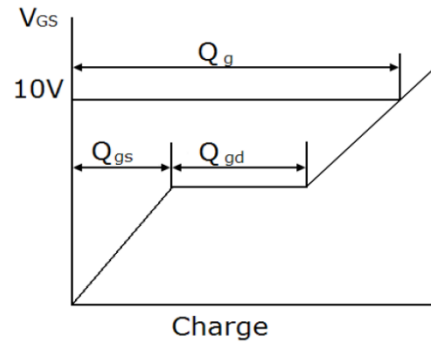
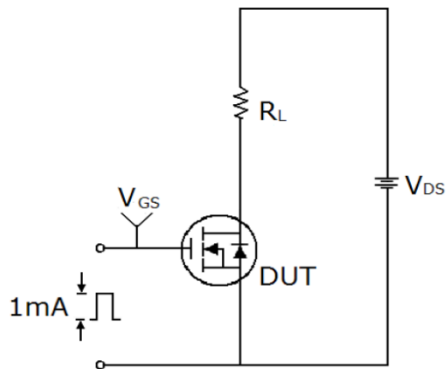

Figure 10. Maximum Safe Operating Area



Test Circuits

Gate Charge Test Circuit & Waveform



Switching Test Circuit & Waveform

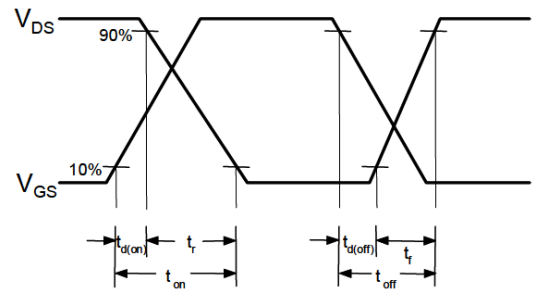
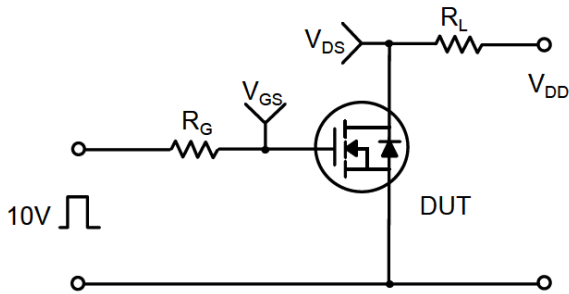

Unclamped Inductive Switching Test Circuit & Waveform

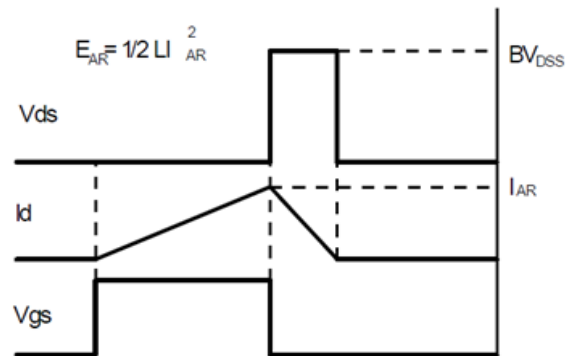
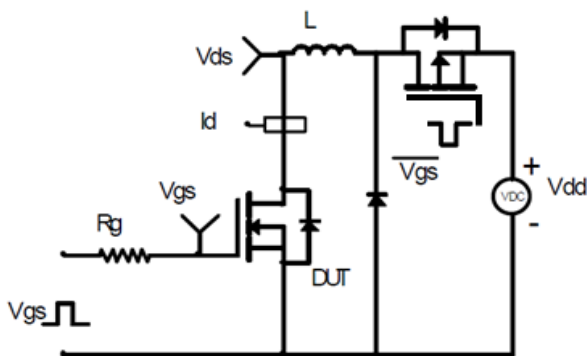

Mechanical Dimensions for DFN5*6

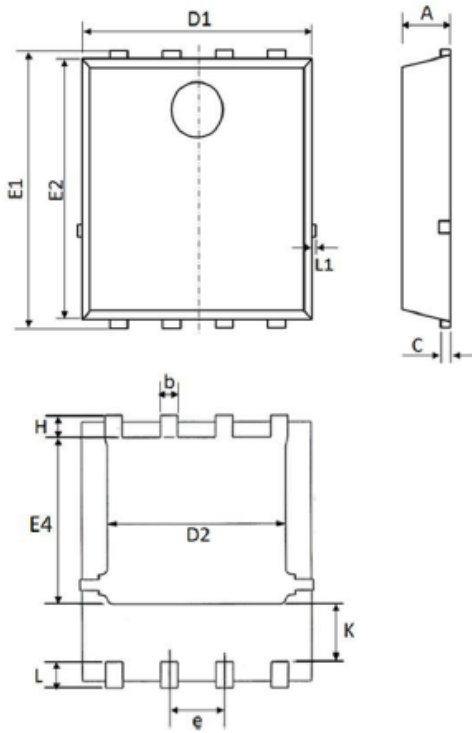

COMMON DIMENSIONS						
SYMBOL	MILLIMETERS			INCHS		
	MIN	NOM	MAX	MIN	NOM	MAX
A	1	1.1	1.2	0.039	0.043	0.047
b	0.3	0.4	0.5	0.012	0.016	0.020
C	0.154	0.254	0.354	0.006	0.010	0.014
D1	5	5.2	5.4	0.197	0.205	0.213
D2	3.8	4.1	4.25	0.150	0.161	0.167
E1	5.95	6.15	6.35	0.234	0.242	0.250
E2	5.66	5.86	6.06	0.223	0.231	0.239
E4	3.52	3.72	3.92	0.139	0.146	0.154
e	1.27 BSC			0.050 BSC		
H	0.4	0.5	0.6	0.016	0.020	0.024
L	0.5	0.6	0.7	0.020	0.024	0.028
L1	-	-	0.12	-	-	0.005
K	1.14	1.29	1.44	0.045	0.051	0.057

Reactor