

SMD ■ Mini Top LEDs

65-21-S2SC-B2S1T1B7E-2T8-AM



Features

- P-LCC-2 package.
- Colorless clear resin.
- Wide viewing angle 120°.
- Inner reflector and white package.
- Brightness: 180 to 355 mcd at 20mA.
- Precondition: Bases on JEDEC J-STD 020D Level 3.
- Qualification according to AEC-Q101 rev C.
- Automotive reflow profile (IR reflow or wave soldering)

Applications

- Automotive backlighting or indicator: Interior and exterior automotive lighting, Dashboard, LCD, signal switch, keys, display, symbol luminaire, audio and video equipments...etc.
- Backlight: LCD, switches, symbol, mobile phone and illuminated advertising.
- Display for indoor and outdoor application.
- Ideal for coupling into light guides.
- Substitution of traditional light.
- Optical indicator.
- General applications.

Device Selection Guide

| Chip Materials | Emitted Color | Resin Color |
|----------------|------------------|-------------|
| AlGaInP | Brilliant Orange | Water Clear |

Absolute Maximum Ratings (Ta=25°C)

| Parameter | Symbol | Rating | Unit |
|---|---------------|---|------|
| Reverse Voltage | V_R | 12 | V |
| Forward Current | I_F | 30 | mA |
| Peak Forward Current (Duty 1/10 @1KHz) | I_{FP} | 100 | mA |
| Power Dissipation | P_d | 120 | mW |
| Junction Temperature | T_j | 125 | °C |
| Operating Temperature | T_{opr} | -40 ~ +100 | °C |
| Storage Temperature | T_{stg} | -40 ~ +110 | °C |
| Thermal resistance | $R_{th\ J-A}$ | 400 | K/W |
| | $R_{th\ J-S}$ | 180 | K/W |
| ESD (Classification acc. AEC Q101) | ESD_{HBM} | 2000 | V |
| | ESD_{MM} | 200 | V |
| Soldering Temperature | T_{sol} | Reflow Soldering : 260 °C for 30 sec. Hand Soldering : 350 °C for 3 sec. | |

Electro-Optical Characteristics (Ta=25°C)

| Parameter | Symbol | Min. | Typ. | Max. | Unit | Condition |
|------------------------------|-----------------|------|------|------|---------------|---------------------|
| Luminous Intensity | I_v | 180 | --- | 355 | mcd | $I_F = 20\text{mA}$ |
| Viewing Angle | $2\theta_{1/2}$ | --- | 120 | --- | deg | $I_F = 20\text{mA}$ |
| Peak Wavelength | λ_p | --- | 611 | --- | nm | $I_F = 20\text{mA}$ |
| Dominant Wavelength | λ_d | 603 | --- | 609 | nm | $I_F = 20\text{mA}$ |
| Spectrum Radiation Bandwidth | $\Delta\lambda$ | --- | 17 | --- | nm | $I_F = 20\text{mA}$ |
| Forward Voltage | V_F | 1.7 | --- | 2.4 | V | $I_F = 20\text{mA}$ |
| Reverse Current | I_R | --- | --- | 10 | μA | $V_R = 12\text{V}$ |

Note:

1. Tolerance of Luminous Intensity: $\pm 11\%$
2. Tolerance of Dominant Wavelength: $\pm 1\text{nm}$
3. Tolerance of Forward Voltage: $\pm 0.1\text{V}$

Bin Range of Luminous Intensity

| Bin Code | Min. | Max. | Unit | Condition |
|----------|------|------|------|---------------------|
| S1 | 180 | 224 | mcd | $I_F = 20\text{mA}$ |
| S2 | 224 | 280 | | |
| T1 | 280 | 355 | | |

Note:

Tolerance of Luminous Intensity: $\pm 11\%$

Bin Range of Dominant Wavelength

| Bin Code | Min. | Max. | Unit | Condition |
|----------|------|------|------|----------------------|
| 1 | 603 | 606 | nm | I _F =20mA |
| 2 | 606 | 609 | | |

Note:
Tolerance of Dominant Wavelength: ± 1 nm

EVERLIGHT

Typical Electro-Optical Characteristics Curves

Typical Curve of Spectral Distribution

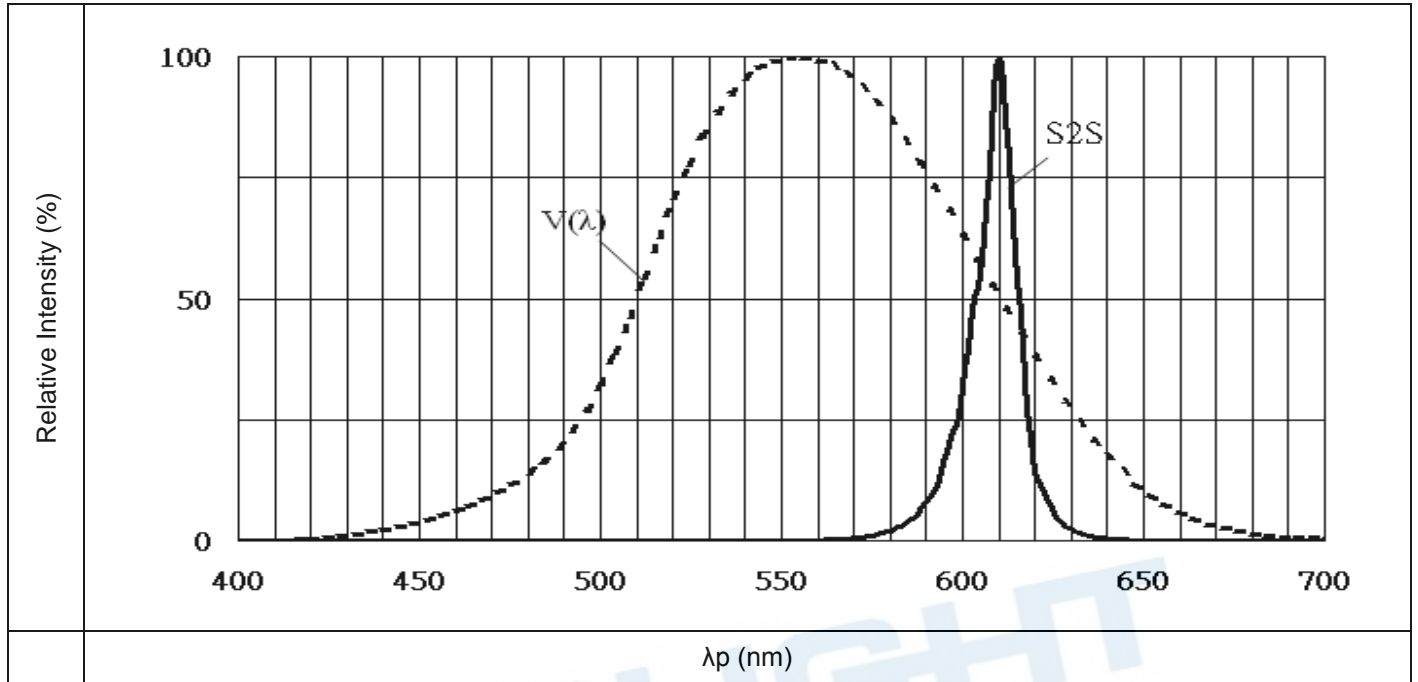

Note: $V(\lambda)$ =Standard eye response curve; $I_F = 20\text{mA}$

Diagram Characteristics of Radiation

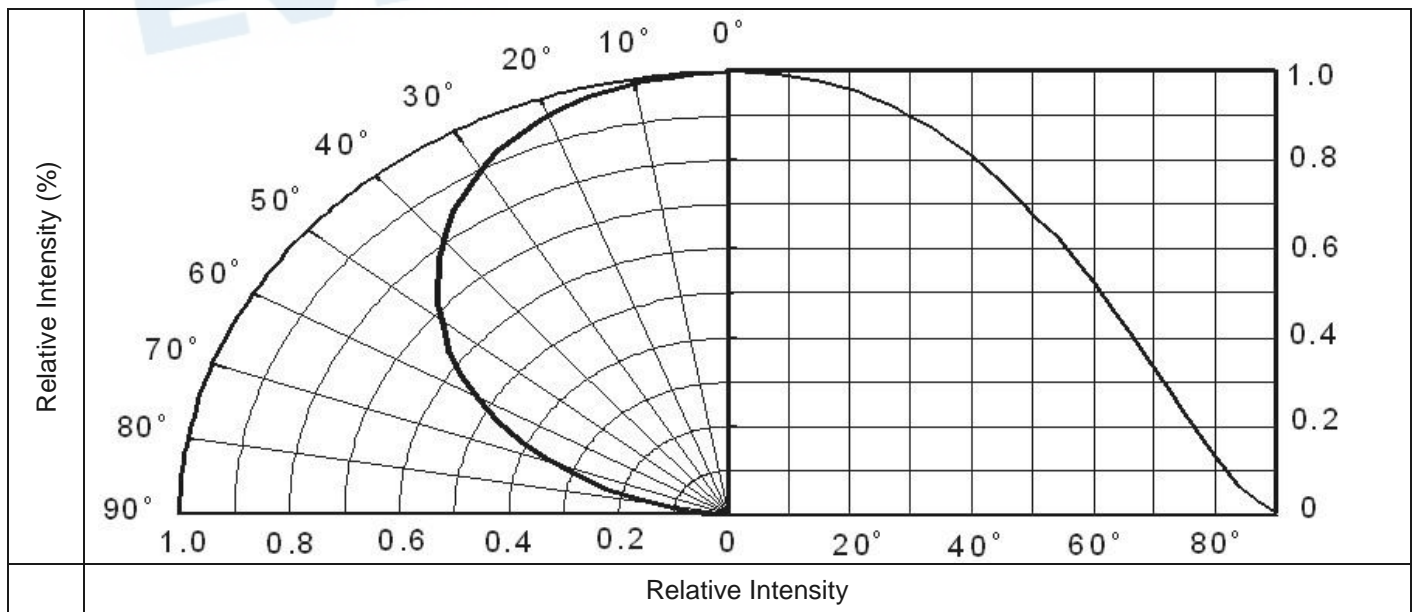

Forward Current vs. Forward Voltage

(Ta=25°C)

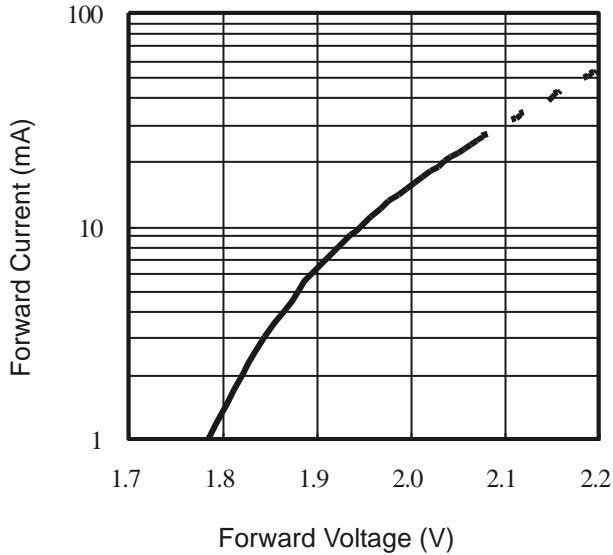

Dominant Wavelength vs. Forward Current

(Ta=25°C)

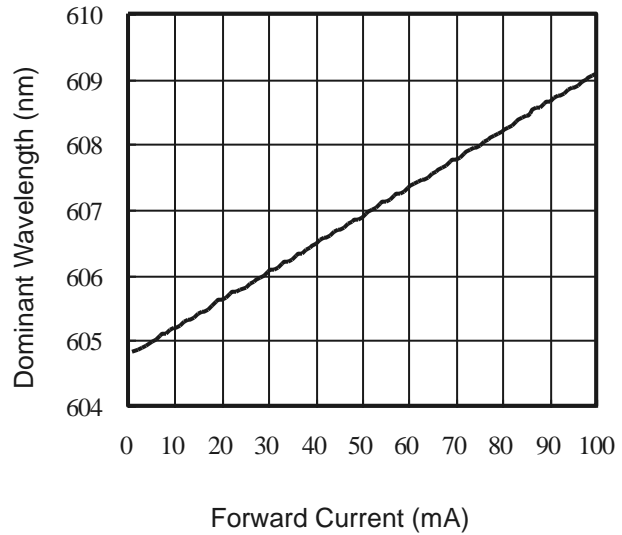

Relative Luminous Intensity vs.

Forward Current (Ta=25°C)

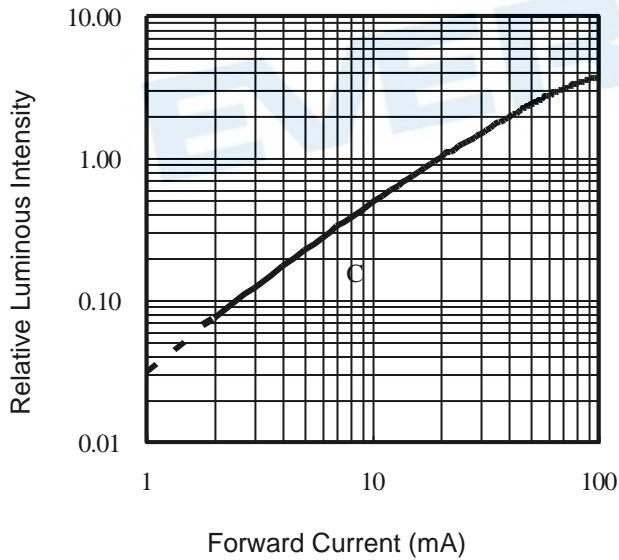

Forward current vs. Ambient and Solder Temperature

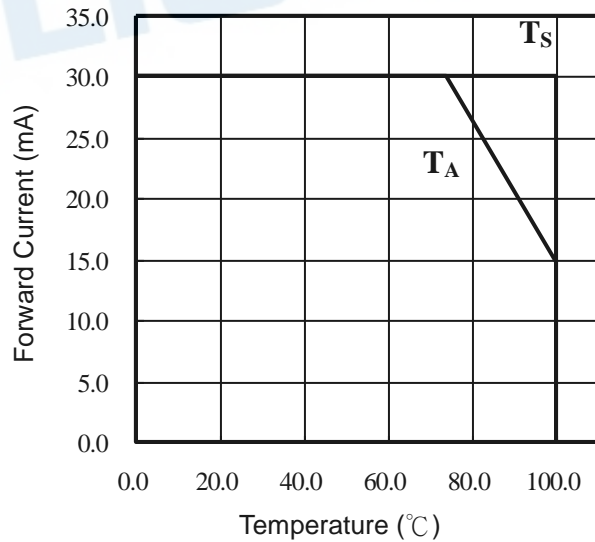

Package Dimension

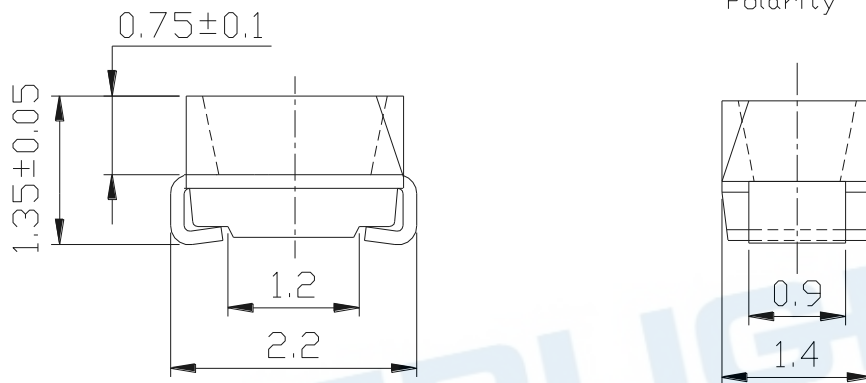
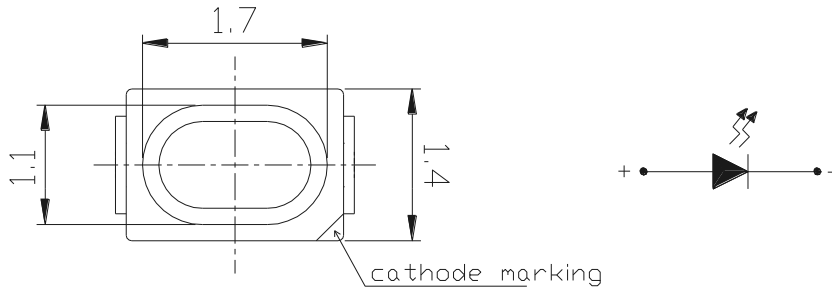

Note: Tolerances unless mentioned ± 0.1 mm. Unit = mm

Moisture Resistant Packing Materials

Label Explanation



- CPN: Customer's Product Number
- P/N: Product Number
- QTY: Packing Quantity
- CAT: Luminous Intensity Rank
- HUE: Dom. Wavelength Rank
- REF: Forward Voltage Rank
- LOT No: Lot Number

Reel Dimensions

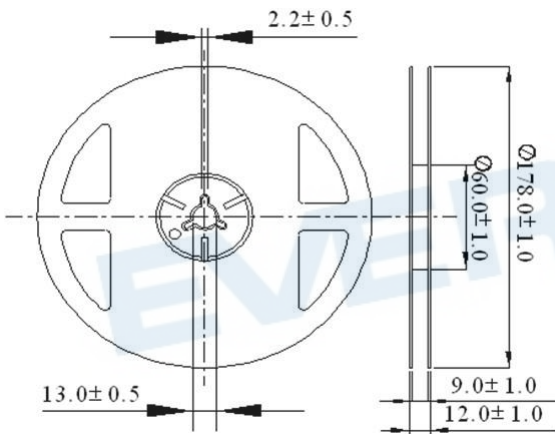

Carrier Tape Dimensions: Loaded Quantity 2000 pcs Per Reel

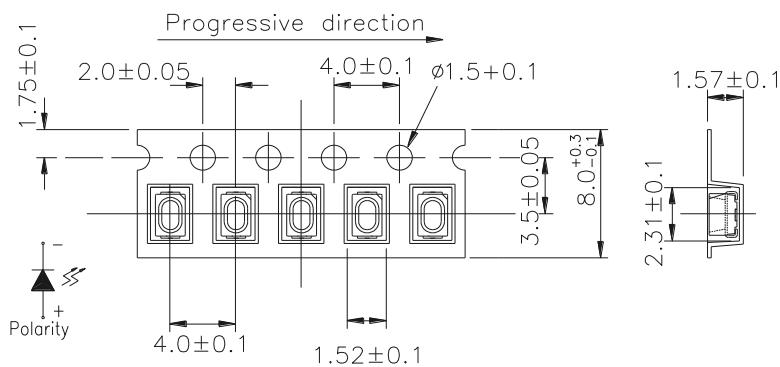

Note: Tolerances unless mentioned ± 0.1 mm. Unit = mm

Moisture Resistant Packing Process

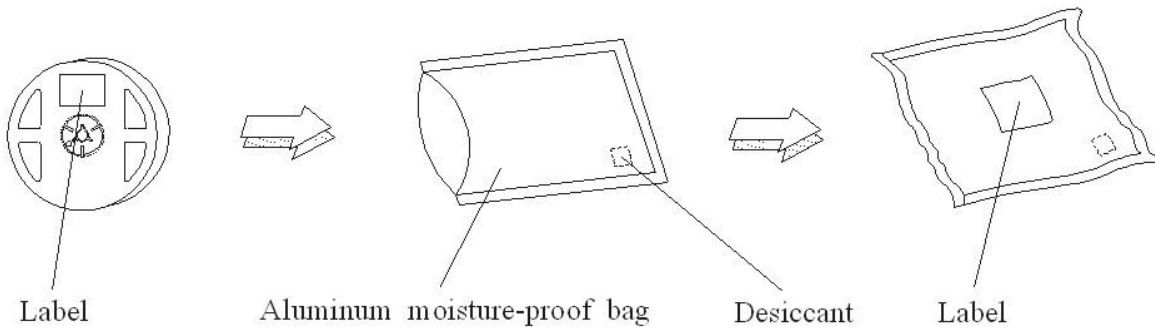

Note: Tolerances unless mentioned $\pm 0.1\text{mm}$. Unit = mm

Precautions for Use

1. Soldering Condition (Reference: IPC/JEDEC J-STD-020D)

a. IR reflow

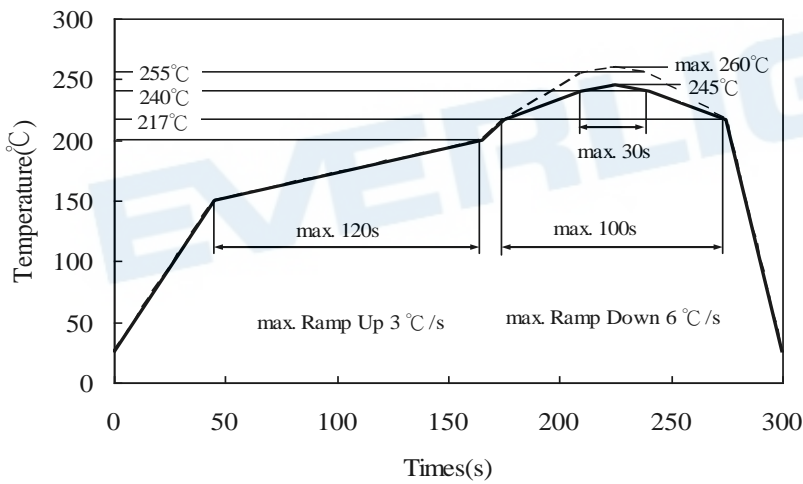

b. Wave soldering reflow

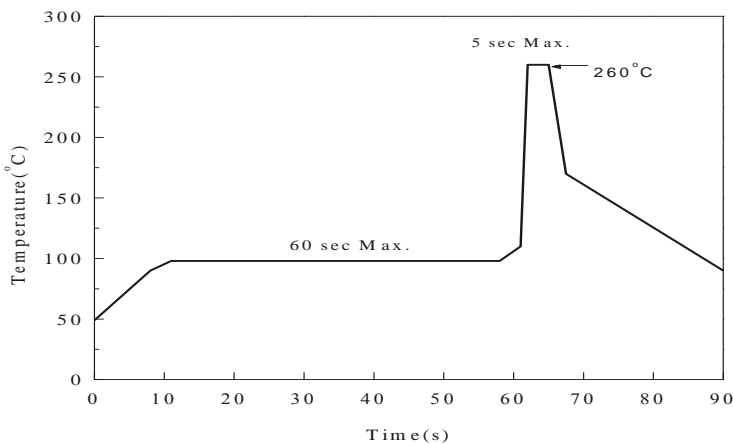

(B) Recommend soldering pad

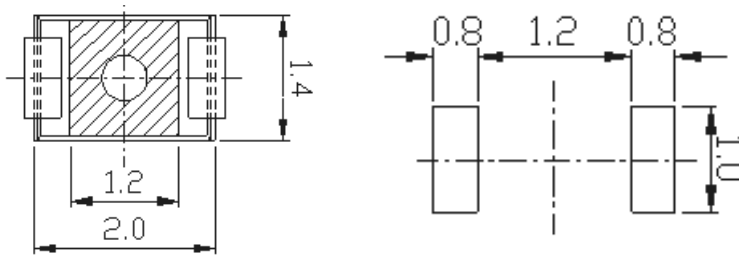

Note: Tolerances unless mentioned ± 0.1 mm. Unit = mm

2. Current limiting

A resistor should be used to limit current spikes that can be caused by voltage fluctuations. Otherwise damage could occur.

3. Storage

- 3.1 Moisture proof bag should only be opened immediately prior to usage.
- 3.2 Environment should be less than 30°C and 60% RH when moisture proof bag is opened.
- 3.3 After opening the package MSL Conditions stated on page 1 of this spec should not be exceeded.
- 3.4 If the moisture sensitivity card indicates higher than acceptable moisture, the component should be baked at min. 60°deg $\pm 5^{\circ}\text{deg}$ for 24 hours.

4. Iron Soldering

Hand soldering is not recommended for regular production. These guidelines are for rework only. Soldering iron tip should contact each terminal no more than 3 sec at 350°C , using soldering iron with nominal power less than 25W. Allow min. 2 sec. between soldering intervals.

5. Usage

Do not exceed the values given in this specification.

Application Restrictions

High reliability applications such as military/aerospace, automotive safety/security systems, and medical equipment may require different product. If you have any concerns, please contact Everlight before using this product in your application. This specification guarantees the quality and performance of the product as an individual component. Do not use this product beyond the specification described in this document