

## THREE-TERMINAL ADJUSTABLE OUTPUT POSITIVE VOLTAGE REGULATORS

The HT317A is adjustable 3-terminal positive voltage regulator capable of supplying in excess of 1.5 A over an output voltage range of 1.2 V to 37 V. These voltage regulator is exceptionally easy to use and require only two external resistors to set the output voltage. Further, it employ internal current limiting, thermal shutdown and safe area compensation, making them essentially blow-out proof.

The HT317A serve a wide variety of applications to make a programmable output regulator, or by connecting a fixed resistor between the adjustment and output, the HT317A series can be used as a precision current regulator.

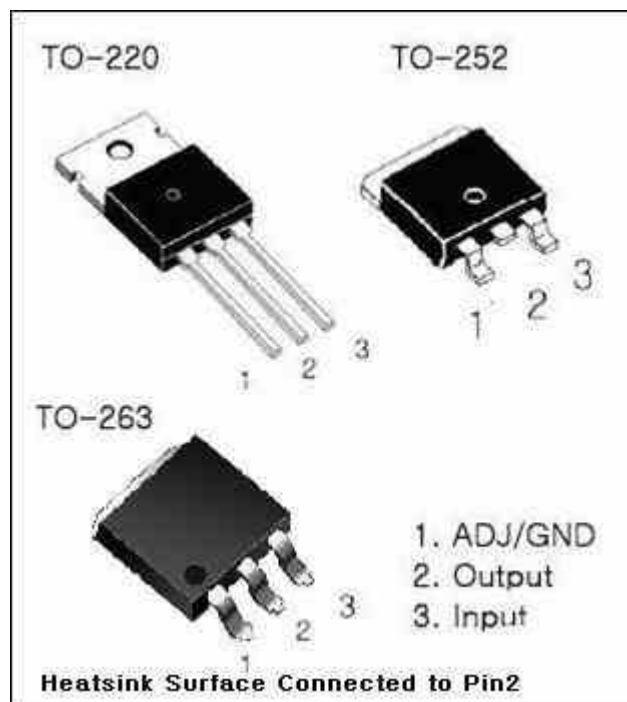

### Futures

- Output Current in Excess of 1.5 Ampere
- Output Adjustable between 1.2 V and 37 V
- Internal Thermal Overload Protection
- Internal Short - Circuit Current Limiting Constant with Temperature
- Output Transistor Safe-Area Compensation
- Floating Operation for High Voltage Applications
- Standard 3-lead Transistor Packages
- Eliminates Stocking Many Fixed

### ORDERING INFORMATION

Device	Operating Temperature Range	Package	Packing
HT317AT	T <sub>A</sub> = -40° to 125° C for all packages	TO-220	Tube
HT317AM		TO-252	Tape & Reel
HT317AS		TO-263	Tape & Reel
HT317AD		TO-223	Tape & Reel
HT317AE		ESOP8	Tape & Reel

### Standard application

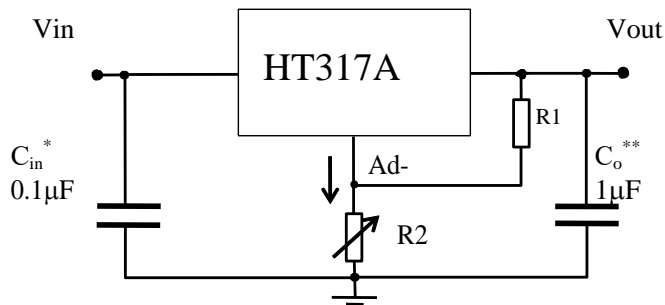

\* = Cin is required if regulator is

located an appreciable distance from power supply filter.

\*\* = Co is not needed for stability ; however, it does improve transient response.

$$V_{out} = 1.25V \left(1 + \frac{R2}{R1}\right) + I_{ADJ} * R2$$

Since IADJ is controlled to less than 100 µA, the error associated with this term is negligible in most applications.

### Maximum ratings

Rating	Symbol	Value	Unit
Input - Output Voltage Differential	Vi - Vo	40	Vdc
Power Dissipation and Thermal Characteristics	PD	Internally Limited	
Operating Junction Temperature Rang	TJ	-40 to +150	°C
Storage Junction Temperature Rang	Tstg	-65 to +150	°C

\* Stresses beyond those listed under "absolute maximum ratings" may cause permanent damage to the device. These are stress ratings only and functional operation of the device at these or any other conditions beyond those indicated under "recommended operating conditions" is not implied. Exposure to absolute-maximum-rated conditions for extended periods may affect device reliability.

**Electrical characteristics**

(Vi-Vo= 5.0V, Io = 0.5 A, Tj = Tlow to Thigh (see Note 1); Imax = 1.5 A and Pmax = 20 W unless otherwise noted)

Characteristic	Symbol	Min	Typ	Max	Unit
Line Regulation (TA=+25°C) 3.0V ≤ Vi - Vo ≤40 V	Regline	-	0.01	0.04	%/V
Load Regulation(TJ=+25°C) 10mA≤Io≤Imax, Vin ≤5V Vin≥5 V	Regload	-	5.0	25	mV
		-	0.1	0.5	%/Vo
Thermal Regulation (TA=+25°C) 20 ms Pulse	-	-	0.03	0.07	%/W
Adjustment Pin Current	IAdj	-	50	100	μA
Adjustment Pin Current Change 2.5 ≤ Vi - Vo ≤ 40 V 10mA ≤IL≤ Imax, PD ≤ Pmax	ΔIAdj	-	0.2	5.0	μA
Reference Voltage (Note 4) 3.0 ≤ Vi - Vo ≤ 40 V 10mA ≤IL≤ Imax, PD ≤ Pmax	Vref	1.2	1.25	1.3	V
Line Regulation (Note 3) 3.0 V ≤ Vi - Vo ≤40 V	Regline	-	0.02	0.07	%/V
Load Regulation (Note 3) 10mA≤Io≤Imax, Vin ≤5V Vin≥5 V	Regload	-	20	70	mV
		-	0.3	1.5	%/V
Temperature Stability (Tlow ≤ Tj ≤ Ttigh)	Ts	-	0.7	-	
Minimum Load Current to Maintain Regulation (Vi - Vo = 40 V)	ILmin	-	3.5	10	mA
Maximum Output Current Vi - Vo≤ 15 V , P ≤ 20 W Vi - Vo = 40 V, P ≤20W, TA=+25°C	Imax	1.5 0.15	2.2 0.4	- -	A
RMS Nose , % of Vo TA=+25°C, 10 Hz ≤ f ≤ 10 kHz	N	-	0.003	-	%/Vo
Ripple Rejection, Vo = 10 V, f = 120 Hz (Note 5) Without Cadj Cadj = 10 μF	RR	- 66	65 80	- -	dB
Long-Term Stability, Tj = Thigh (Note 6) TA=+25°C for Endpoint Measurements	S	-	0.3	1.0	%/1.0 k Hrs.
Thermal Resistance Junction to Case	RθJC	-	5.0	-	°C/W

Notes: (1) Tlow = -40 °C , Thigh = +125 °C

(2) Imax = 0.5 A , Pmax

(3) Load and line regulation are specified at constant junction temperature. Changes in Vo due to heating effects must be taken into account separately. Pulse testing with low duty cycle is used.

(4) Selected devices with tightened tolerance reference voltage available.

(5) Cadj , when used, connected between the adjustment pin and ground.

(6) Since Long - Term Stability cannot be measured on each device before shipment, this specification is an engineering estimate of average stability from lot to lot.

**TO-220AB PKG OUTLINE DIMENSIONS**

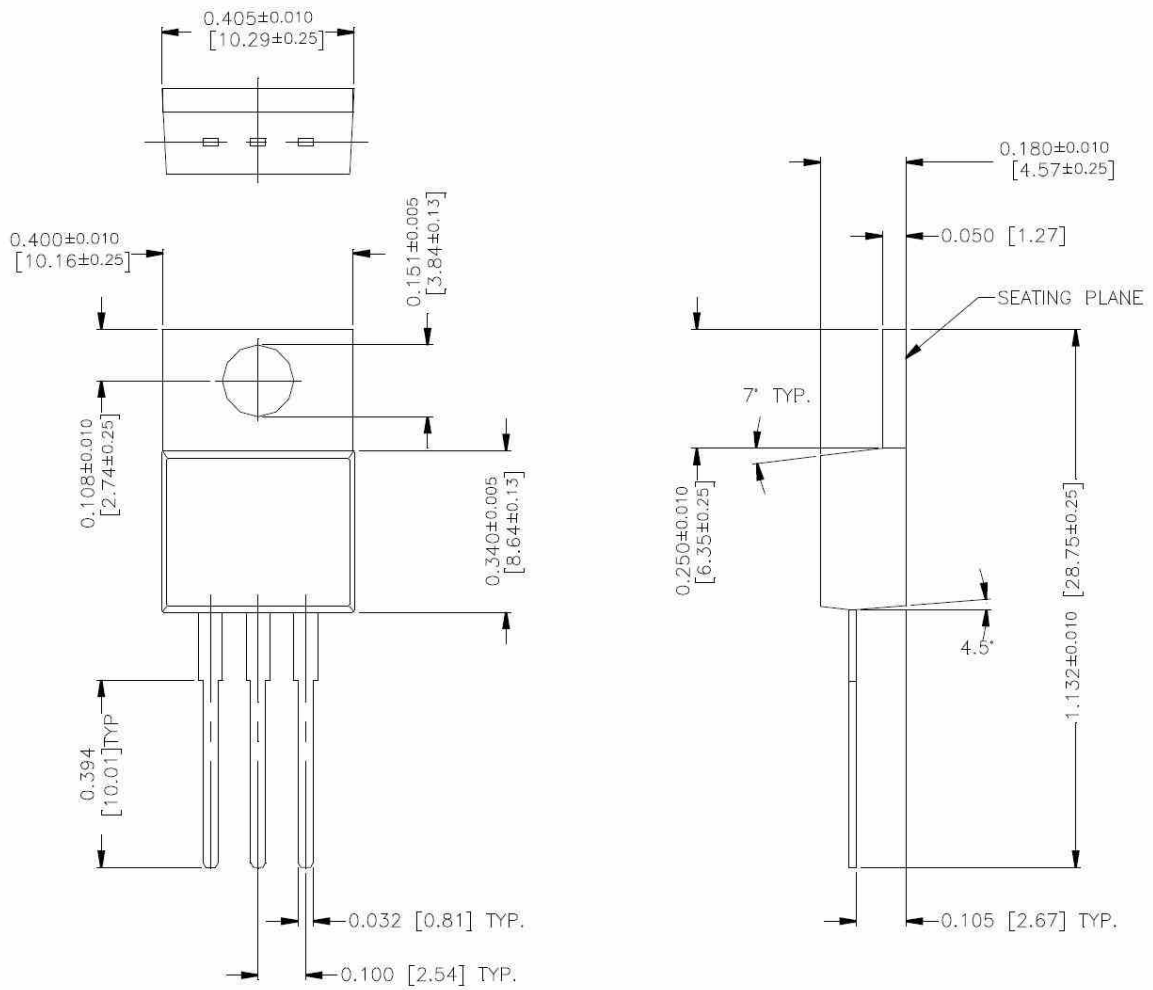

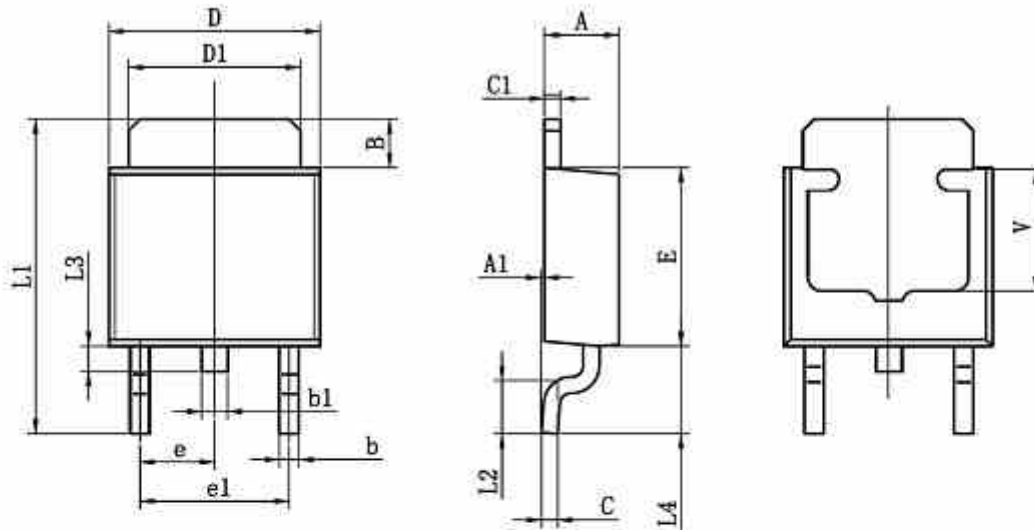
**TO-252 PACKAGE OUTLINE DIMENSIONS**

Symbol	Dimensions In Millimeters		Dimensions In Inches	
	Min	Max	Min	Max
A	2.200	2.400	0.087	0.094
A1	0.000	0.127	0.000	0.005
B	1.350	1.650	0.053	0.065
b	0.500	0.700	0.020	0.028
b1	0.700	0.900	0.028	0.035
c	0.430	0.580	0.017	0.023
c1	0.430	0.580	0.017	0.023
D	6.350	6.650	0.250	0.262
D1	5.200	5.400	0.205	0.213
E	5.400	5.700	0.213	0.224
e	2.300TYP		0.091TYP	
e1	4.500	4.700	0.177	0.185
L1	9.500	9.900	0.374	0.390
L2	1.400	1.780	0.055	0.070
L3	0.650	0.950	0.026	0.037
L4	2.550	2.900	0.100	0.114
V	3.80REF		0.150REF	

TO-263-3L PKG OUTLINE DIMENSIONS

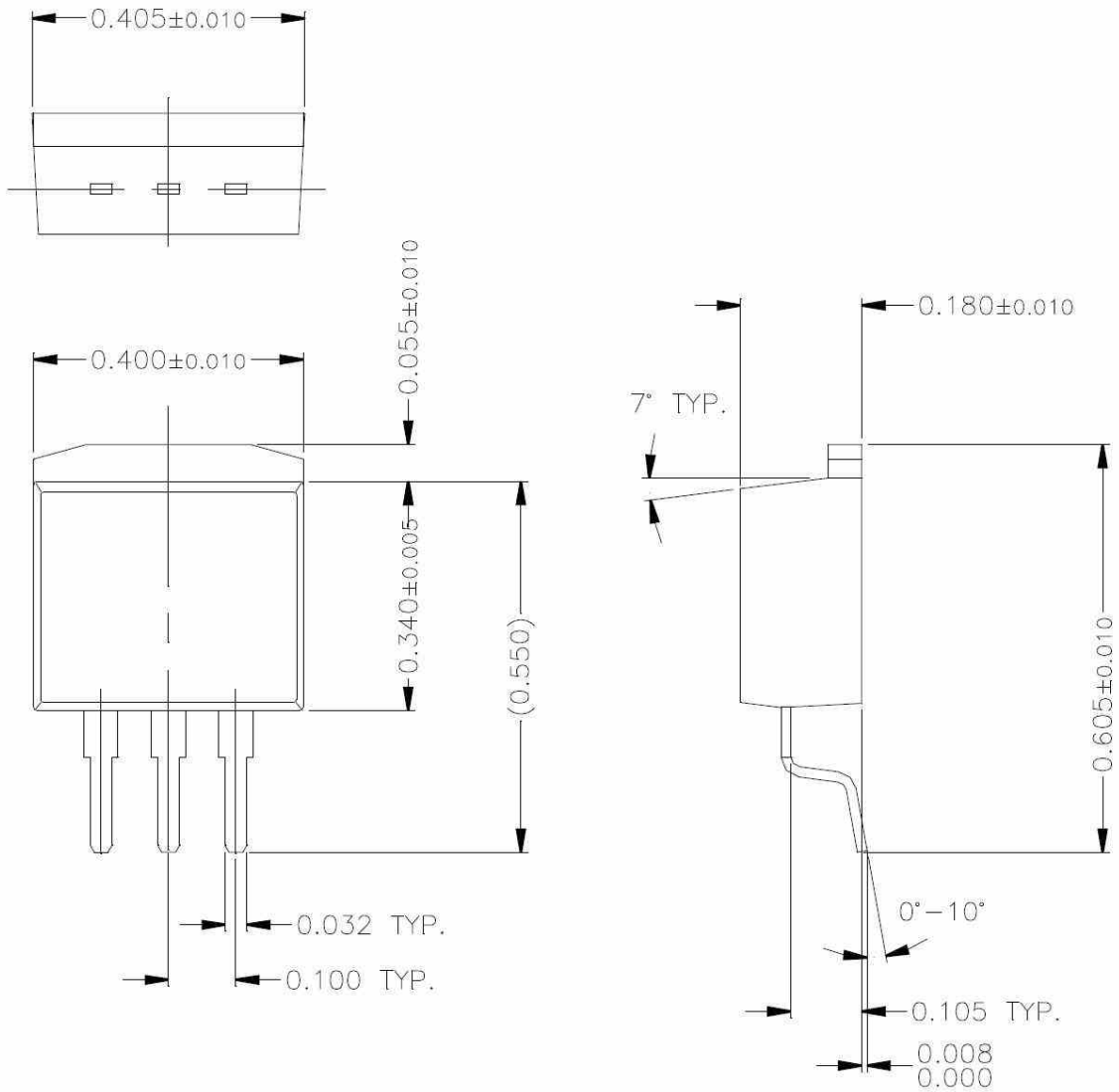

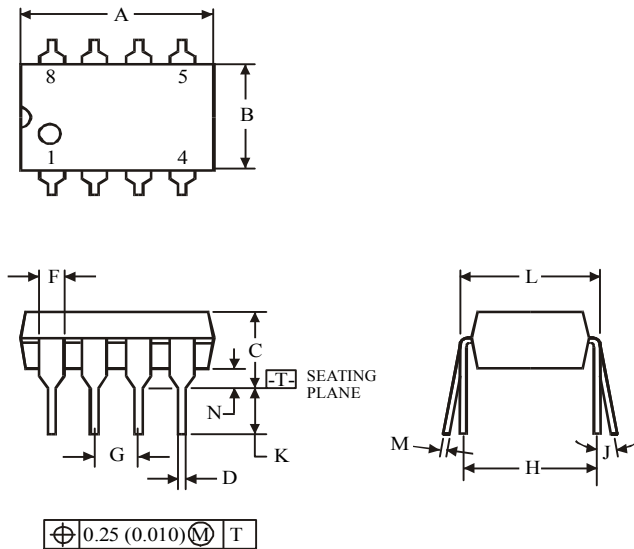
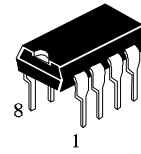
**(DIP8)**

Symbol	Dimension, mm	
	MIN	MAX
A	8.51	10.16
B	6.1	7.11
C		5.33
D	0.36	0.56
F	1.14	1.78
G	2.54	
H	7.62	
J	0°	10°
K	2.92	3.81
L	7.62	8.26
M	0.2	0.36
N	0.38	

**NOTES:**

- Dimensions "A", "B" do not include mold flash or protrusions.  
Maximum mold flash or protrusions 0.25 mm (0.010) per side.

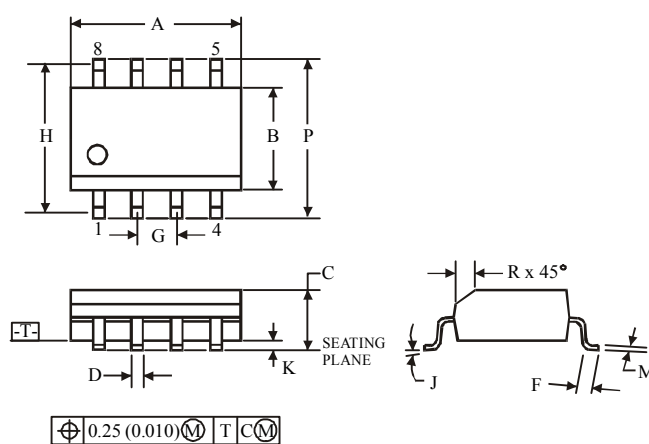
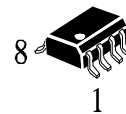
**(SOP8)**

Symbol	Dimension, mm	
	MIN	MAX
A	4.8	5
B	3.8	4
C	1.35	1.75
D	0.33	0.51
F	0.4	1.27
G	1.27	
H	5.72	
J	0°	8°
K	0.1	0.25
M	0.19	0.25
P	5.8	6.2
R	0.25	0.5

**NOTES:**

- Dimensions A and B do not include mold flash or protrusion.
- Maximum mold flash or protrusion 0.15 mm (0.006) per side for A; for B - 0.25 mm (0.010) per side.