



SOD-323 Plastic-Encapsulate Diodes

SD103AWS-SD103CWS SCHOTTKY BARRIER DIODE

FEATURES

- Low Forward Voltage Drop
- Guard Ring Construction for Transient Protection
- Negligible Reverse Recovery Time
- Low Reverse Capacitance

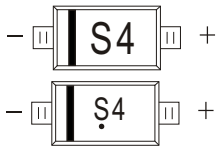
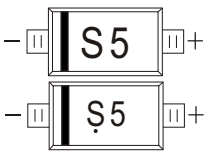
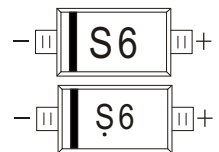
MARKING:

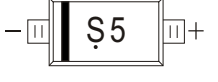
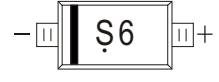
SD103AWS:S4	SD103BWS:S5	SD103CWS:S6
		
		

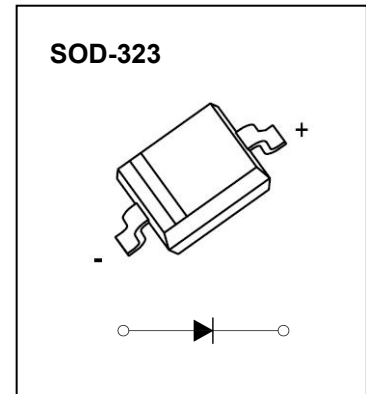

The marking bar indicates the cathode
 Solid dot = Green molding compound device, if none, the normal device.

Maximum Ratings and Electrical Characteristics, Single Diode @Ta=25°C

Parameter	Symbol	SD103AWS	SD103BWS	SD103CWS	Unit
Peak Repetitive Peak Reverse Voltage	V_{RRM}				
Working Peak Reverse Voltage	V_{RWM}	40	30	20	V
DC Blocking Voltage	V_R				
RMS Reverse Voltage	$V_{R(RMS)}$	28	21	14	V
Forward Continuous Current	I_{FM}		350		mA
Repetitive Peak Forward Surge Current @1, " a s	I_{FSM}		2.0		A
Power Dissipation	P_d		200		mW
Thermal Resistance Junction to Ambient	$R_{\theta JA}$		500		°C/W
Junction Temperature	T_j		125		°C
Storage Temperature	T_{STG}		-55~+150		°C

Electrical Ratings @Ta=25°C

Parameter	Symbol	Min	Typ	Max	Unit	Conditions
Reverse breakdown voltage	$V_{(BR)}$	40			V	$I_R=100\mu A$
SD103AWS		30				$I_R=100\mu A$
SD103BWS		20				$I_R=100\mu A$
Forward voltage	V_F			0.37 0.60	V	$I_F=20mA$ $I_F=200mA$
Reverse current	I_{RM}			5.0		μA
SD103AWS						
SD103BWS						
Capacitance between terminals	C_T			50	pF	$V_R=0V, f=1.0MHz$
Reverse recovery time	t_{rr}		10		ns	$I_F=I_R=200mA$ $I_{rr}=0.1I_R, R_L=100\Omega$

Typical Characteristics

Forward Characteristics

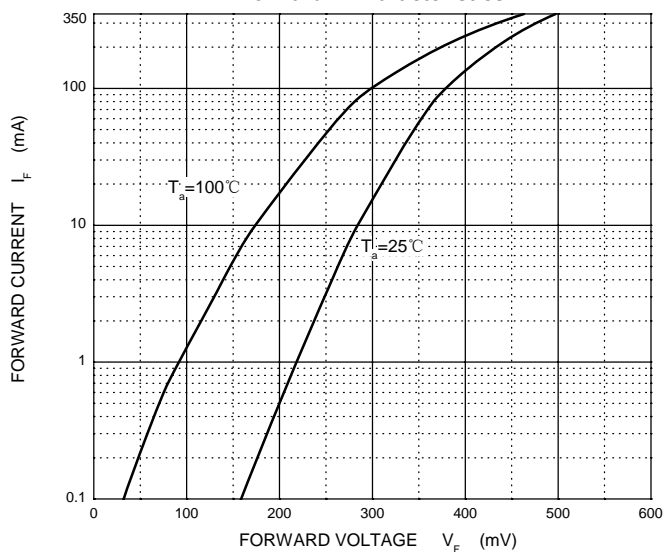

Reverse Characteristics

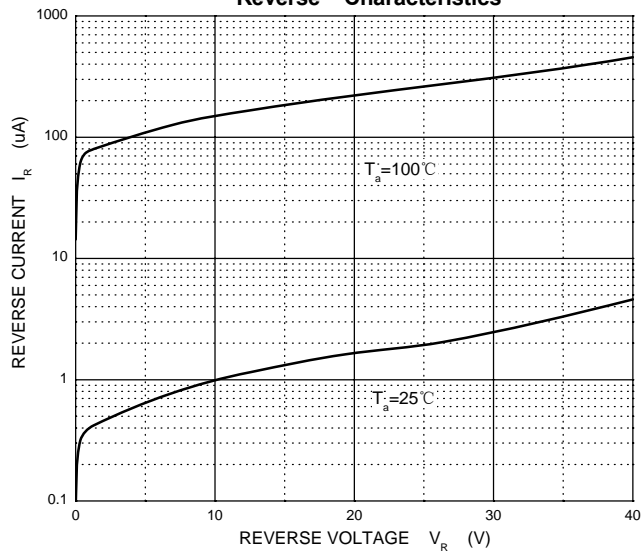

Capacitance Characteristics

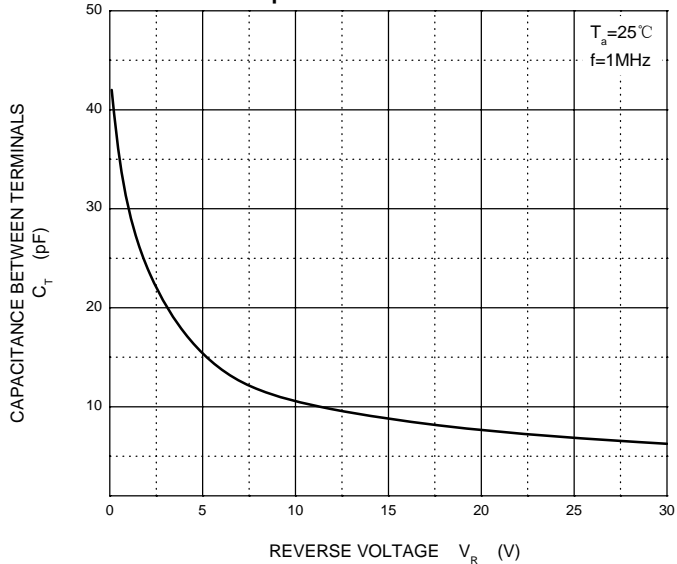

Power Derating Curve

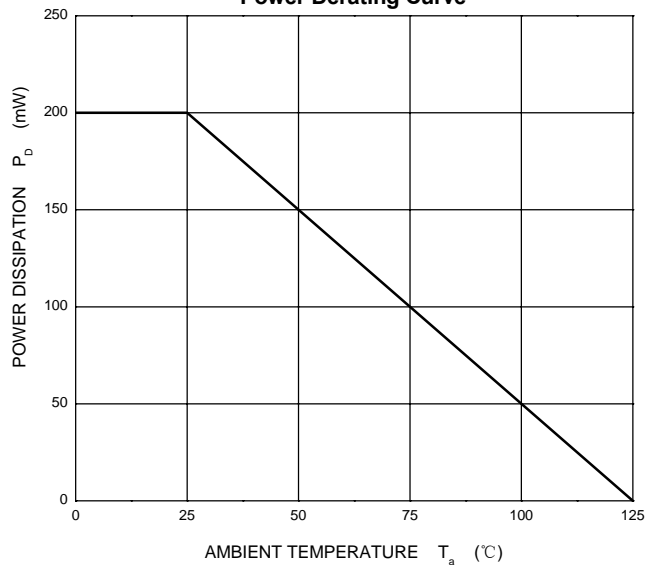

SOD-323 Package Outline Dimensions

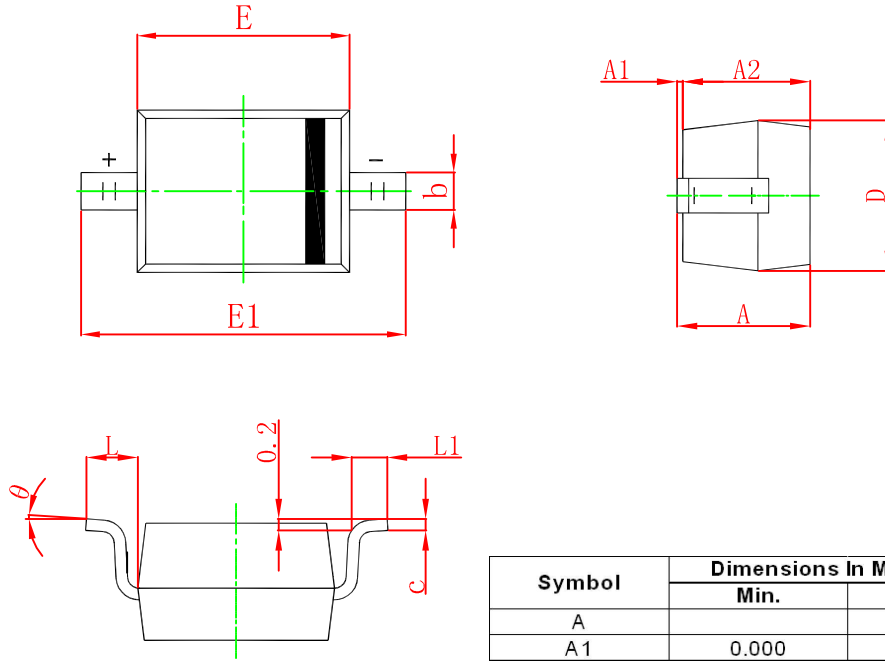

Symbol	Dimensions In Millimeters		Dimensions In Inches	
	Min.	Max.	Min.	Max.
A		1.000		0.039
A1	0.000	0.100	0.000	0.004
A2	0.800	0.900	0.031	0.035
b	0.250	0.350	0.010	0.014
c	0.080	0.150	0.003	0.006
D	1.200	1.400	0.047	0.055
E	1.600	1.800	0.063	0.071
E1	2.550	2.750	0.100	0.108
L	0.475 REF.		0.019 REF.	
L1	0.250	0.400	0.010	0.016
θ	0°	8°	0°	8°

SOD-323 Suggested Pad Layout

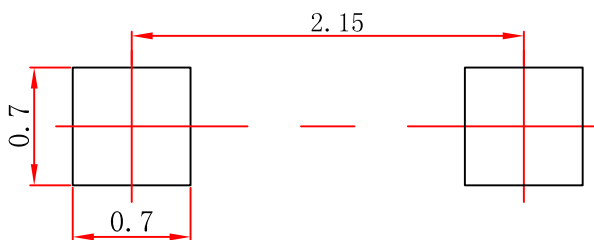

Note:

1. Controlling dimension: in millimeters.
2. General tolerance: $\pm 0.05\text{mm}$.
3. The pad layout is for reference purposes only.

NOTICE

JCET reserve the right to make modifications, enhancements, improvements, corrections or other changes without further notice to any product herein. JCET does not assume any liability arising out of the application or use of any product described herein.

SOD-323 Tape and Reel

SOD-323 Embossed Carrier Tape



Packaging Description:

SOD-323 parts are shipped in tape. The carrier tape is made from a dissipative (carbon filled) polycarbonate resin. The cover tape is a multilayer film (Heat Activated Adhesive in nature) primarily composed of polyester film, adhesive layer, sealant, and anti-static sprayed agent. These reeled parts in standard option are shipped with 3,000 units per 7" or 17.8cm diameter reel. The reels are clear in color and is made of polystyrene plastic (anti-static coated).

Dimensions are in millimeter										
Pkg type	A	B	C	d	E	F	P0	P	P1	W
SOD-323	1.48	3.3	1.25	Ø1.50	1.75	3.50	4.00	4.00	2.00	8.00

SOD-323 Tape Leader and Trailer

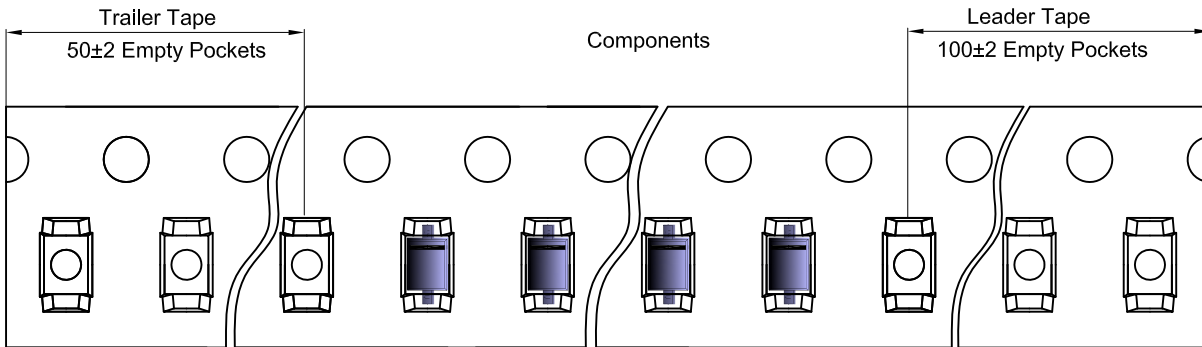

SOD-323 Reel

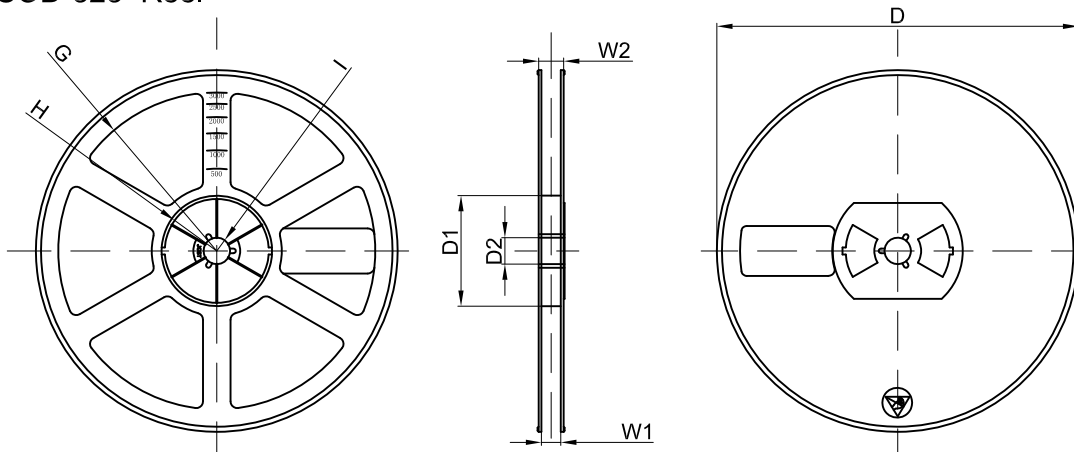

Dimensions are in millimeter								
Reel Option	D	D1	D2	G	H	I	W1	W2
7" Dia	Ø178.00	54.40	13.00	R78.00	R25.60	R6.50	9.50	12.30

REEL	Reel Size	Box	Box Size(mm)	Carton	Carton Size(mm)	G.W.(kg)
3000 pcs	7 inch	45,000 pcs	203×203×195	180,000 pcs	438×438×220	