

Document No.	Specifications
MLRME1600059	Multilayer Ceramic Capacitor (High dielectric type)

1. Scope

This specification covers multilayer chip type ceramic capacitor (Pb-Free) for use (for reflow soldering) in electronic appliances and electric communications equipment.

2. Part Numbering System

Part number is indicated as follows.

(Example) J DK 063 A BJ 225 M P -F
 ① ※ ② ③ ④ Capacitance ⑤ ⑥ ⑦

※Voltage in high temperature loading test.(100%)

①Rated voltage

Code	Voltage [VDC]
J	6.3

②Size

Code	L×W [mm]
063	0.6×0.3

③Control Code

※Per Fig.1.

④Temperature characteristics (High dielectric type)

Characteristic	Capacitance change rate [%]	Temperature range [°C]	Reference temperature [°C]
BJ(X5R)	±15(EIA)	-55 to +85	25

⑤Tolerance

Code	Tolerance
M	±20%

⑥Thickness code

Code	Thickness [mm]
P	0.3

⑦Packaging

Code	Packaging
- F	Taping

Multilayer Ceramic Chip Capacitor

3. Test Conditions

Standard test conditions shall be temperature of 5 to 35°C, relative humidity of 45 to 85% and air pressure of 86 to 106kPa. Tests shall be conducted at temperature of 25±3°C, relative humidity of 60 to 70% and air pressure of 86 to 106kPa if test results are suspicious.

Unless otherwise specified, all tests shall be conducted under the standard test conditions.

4. Construction, Dimensions and Performance

Details of construction, dimensions and performance shall be specified in the following sheets.

5. Packaging

Capacitors shall be packaged properly to avoid damage in the capacitors during transportation and storage.

The package shall be marked with part number, quantity, lot number, and manufacturer's name at its appropriate position.

6. Manufacturing site

TAIYO YUDEN CO., LTD. (JAPAN)

TAIYO YUDEN (GUANG DONG) CO., LTD. (CHINA)

TAIYO YUDEN (SARAWAK) SDN. BHD. (MALAYSIA)

TAIYO YUDEN (PHILIPPINES), INC. (PHILIPPINES)

7. Precautions

- This specification does not cover capacitors when Sn-Zn lead free solder is used.

If you need further information, please contact us.

8. Storage conditions

- Temperature and humidity in storage area shall be controlled carefully to maintain the solderability of terminal electrodes and to keep the packaging material in good condition. Humidity should especially be kept as low as possible.

- Recommended conditions

Ambient temperature: 30°C or below

Humidity: 70% RH or below

The ambient temperature must be kept below +40°C. Even under ideal storage conditions, capacitor electrode solderability decreases with time. Therefore ceramic chip capacitors should be used within 6 months from the time of delivery. If the period is exceeded, please check solderability before using the capacitors.

- The packaging material should be kept where no chlorine or sulfur exists in the air.

Multilayer Ceramic Chip Capacitor

9. RoHS compliance

- Our products conform to RoHS.
- "RoHS compliance" means that the product does not contain lead, cadmium, mercury, hexavalent chromium, PBB or PBDE referring to EU Directive 2011/65/EU, except other non-restricted substances or impurities which cannot be technically removed at refining process.
- Our products are halogen-free products.

10. Others

Resin-coating:

- Coating/molding capacitors with resin may have negative effects on the capacitor functions.
- When capacitors are coated/molded with resin, please check effects on the capacitors by analyzing them in actual applications prior to use.

No.	Item	Specified Value	Remarks				
1	Operating Temperature Range	Capable of continuous operation under these conditions.	-55 to +85°C				
2	Shape and Dimensions	Per Fig.1					
3	Heat Treatment		Initial value shall be measured after test sample is heat-treated at 150 +0/-10°C for an hour and kept at room temperature for 24±2 hours.				
4	Voltage Treatment		Initial value shall be measured after test sample is voltage-treated for an hour at temperature and voltage which are specified as test conditions, and kept at room temperature for 24±2 hours.				
5	Dielectric Withstanding Voltage (between terminals)	No abnormality.	Conforming to EIA RS-198 (1991). 160% of DC rated voltage for high dielectric type shall be applied for 1 to 5 seconds. Charging and discharging current shall be 50mA or less.				
6	Insulation Resistance (IR)	20MΩ·μFmin.	Conforming to EIA RS-198 (1991). Rated voltage shall be applied to test sample for 1 minute±5 seconds. Charging and discharging current shall be 50mA or less.				
7	Capacitance (Cap.)	2.2μF	Conforming to EIA RS-198 (1991). Heat treatment specified in this specification shall be conducted prior to measurement. Measuring frequency and voltage shall conform to the table below. <table border="1" data-bbox="842 1128 1299 1227"> <tr> <td>Measuring Frequency</td> <td>Measuring Voltage</td> </tr> <tr> <td>1kHz±10%</td> <td>0.5±0.1Vrms</td> </tr> </table>	Measuring Frequency	Measuring Voltage	1kHz±10%	0.5±0.1Vrms
Measuring Frequency	Measuring Voltage						
1kHz±10%	0.5±0.1Vrms						
8	Dissipation Factor (DF)	20.0%max.	Conforming to EIA RS-198 (1991). Heat treatment specified in this specification shall be conducted prior to measurement. Measuring frequency and voltage shall conform to the table below. <table border="1" data-bbox="850 1442 1289 1541"> <tr> <td>Measuring Frequency</td> <td>Measuring Voltage</td> </tr> <tr> <td>1kHz±10%</td> <td>0.5±0.1Vrms</td> </tr> </table>	Measuring Frequency	Measuring Voltage	1kHz±10%	0.5±0.1Vrms
Measuring Frequency	Measuring Voltage						
1kHz±10%	0.5±0.1Vrms						

No.	Item	Specified Value	Remarks				
9	Temperature Characteristic	Per P.1④	<p>Heat treatment specified in this specification shall be conducted prior to measurement. Maximum capacitance deviation in both (+) and (-) sides in range of lowest temperature to highest temperature for capacitor shall be indicated in ratio of variation in reference to capacitance value at reference temperature.</p> <table border="1" data-bbox="890 533 1329 629"> <thead> <tr> <th data-bbox="890 533 1098 591">Measuring Frequency</th> <th data-bbox="1098 533 1329 591">Measuring Voltage</th> </tr> </thead> <tbody> <tr> <td data-bbox="890 591 1098 629">1kHz±10%</td> <td data-bbox="1098 591 1329 629">0.2±0.05Vrms</td> </tr> </tbody> </table>	Measuring Frequency	Measuring Voltage	1kHz±10%	0.2±0.05Vrms
Measuring Frequency	Measuring Voltage						
1kHz±10%	0.2±0.05Vrms						
10	Adhesive Force of Terminal Electrodes	Terminal electrodes shall be no exfoliation or a sign of exfoliation.	<p>Conforming to EIA RS-198 (1991). Test sample shall be soldered to test board shown in Fig.2 and a force of 2N(200gf) shall be applied in vertically downward direction for 10±1 seconds.</p>				
11	Vibration	Initial performance shall be satisfied.	<p>Conforming to EIA RS-198 (1991). Test sample shall be soldered to test board shown in Fig.2. Heat treatment specified in this specification shall be conducted prior to test.</p> <p>Test conditions: Frequency range: 10-55Hz Overall amplitude: 1.5mm Sweeping method: 10-55-10Hz for 1 min. Each two hours in X,Y,Z direction: 6 hours in total</p>				

No.	Item	Specified Value	Remarks															
12	Solderability	More than 95% of terminal electrode shall be covered with fresh solder.	<p>【Eutectic】 Solder used shall be [JIS Z 3282 H60A or H63A]. Test sample shall be completely submerged in molten solder at 230±5°C for 4±1 seconds.</p>															
			<p>【Pb free】 Solder used shall be [Sn/3.0Ag/0.5Cu]. Test sample shall be completely submerged in molten solder at 245±3°C for 4±1 seconds.</p>															
13	Resistance to Soldering Heat	Appearance	No abnormality															
		Cap. Change	±25.0%															
		DF	20.0%max.															
		IR	Initial value shall be satisfied.															
		Dielectric Withstanding Voltage (between terminals)	No dielectric breakdown or damage															
			<p>Conforming to EIA RS-198 (1991). Solder used shall be [JIS Z 3282 H60A or H63A]. Heat treatment specified in this specification shall be conducted prior to test. Test sample shall be completely submerged in molten solder of 270±5°C for 3±0.5seconds. Preheating as shown in the table below shall be continuously conducted before submersion and test sample shall be kept at ambient temperature after test.</p> <table border="1"> <thead> <tr> <th>Temperature (°C)</th> <th>Time (min)</th> </tr> </thead> <tbody> <tr> <td>150±1</td> <td>1 to 2</td> </tr> </tbody> </table> <p>Measurement shall be conducted after test sample is kept at ambient temperature for 24±2 hours.</p>	Temperature (°C)	Time (min)	150±1	1 to 2											
Temperature (°C)	Time (min)																	
150±1	1 to 2																	
14	Thermal Shock	Appearance	No abnormality															
		Cap. Change	±40.0%															
		DF	20.0%max.															
		IR	Initial value shall be satisfied.															
		Dielectric Withstanding Voltage (between terminals)	No dielectric breakdown or damage															
			<p>Conforming to EIA RS-198 (1991). Test sample shall be soldered to test board shown in Fig.2. Heat treatment specified in this specification shall be conducted prior to test. Test sample shall be exposed to each of temperature conditions in the following Steps 1 to 4 in sequence for the specified time.</p> <table border="1"> <thead> <tr> <th>Step</th> <th>Temperature (°C)</th> <th>Time (min)</th> </tr> </thead> <tbody> <tr> <td>1</td> <td>Lowest operating temperature</td> <td>30±3</td> </tr> <tr> <td>2</td> <td>Ambient temperature</td> <td>2 to 3</td> </tr> <tr> <td>3</td> <td>Highest operating temperature</td> <td>30±3</td> </tr> <tr> <td>4</td> <td>Ambient temperature</td> <td>2 to 3</td> </tr> </tbody> </table> <p>Temperature cycle shall be repeated five times in this method, and measurement shall be conducted after test sample is kept at ambient temperature for 24±2 hours.</p>	Step	Temperature (°C)	Time (min)	1	Lowest operating temperature	30±3	2	Ambient temperature	2 to 3	3	Highest operating temperature	30±3	4	Ambient temperature	2 to 3
Step	Temperature (°C)	Time (min)																
1	Lowest operating temperature	30±3																
2	Ambient temperature	2 to 3																
3	Highest operating temperature	30±3																
4	Ambient temperature	2 to 3																

No.	Item	Specified Value	Remarks	
15	Humidity (Steady State)	Appearance	No abnormality	Conforming to EIA RS-198 (1991). Heat treatment specified in this specification shall be conducted prior to test. Test sample shall be put into constant temperature/humidity bath at 40±2°C and 90 to 95%RH for 500+24/-0 hours. Measurement shall be conducted after test sample is kept at ambient temperature for the 24±2 hours.
		Cap. Change	±25.0%	
		DF	20.0%max.	
		IR	2MΩ·μFmin.	
16	High Temperature Loading	Appearance	No abnormality	Conforming to EIA RS-198 (1991). Voltage treatment specified in this specification shall be conducted prior to test. Test sample shall be put in thermostatic oven with maximum temperature and 100% of DC rated voltage shall be continuously applied for 1000+48/-0 hours. Charging and discharging current shall be 50mA or less. Measurement shall be conducted after test sample is kept at ambient temperature for 24±2 hours.
		Cap. Change	±25.0%	
		DF	20.0%max.	
		IR	2MΩ·μFmin.	
17	Humidity Loading	Appearance	No abnormality	Conforming to EIA RS-198 (1991). Voltage treatment specified in this specification shall be conducted prior to test. Test sample shall be put into constant temperature/humidity bath at 40±2°C and 90 to 95%RH, and DC rated voltage shall be continuously applied for 500 +24/-0 hours. Charging and discharging current shall be 50mA or less. Measurement shall be conducted after test sample is kept at ambient temperature for 24±2 hours.
		Cap. Change	±60.0%	
		DF	20.0%max.	
		IR	1MΩ·μFmin.	
18	Bending Strength	Appearance	No abnormality	Test sample shall be soldered to test board as shown in Fig.3. Sample shall be carefully soldered to avoid abnormality such as heat shock. The board is bent 1.0mm for 10 seconds as shown in Fig.4. Measurement shall be conducted as the board is bent 1.0mm.
		Cap. Change	±12.5%	

Fig.1 Shape and Dimensions

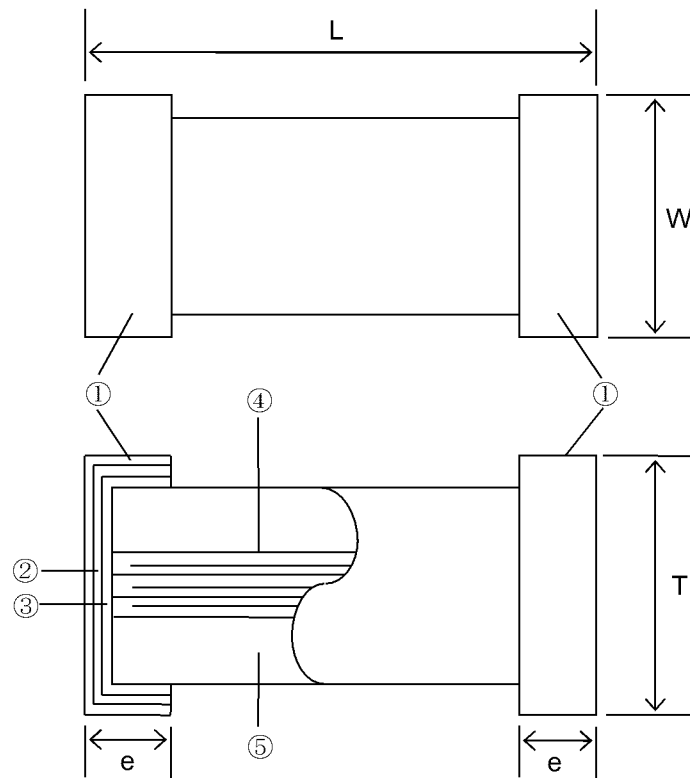

[High dielectric type]

No.	Name	Material
①	Terminal Electrodes (Surface)	Sn Plating
②	Terminal Electrodes	Ni Plating
		Cu Plating
③	External Electrodes	Ni
④	Internal Electrodes	Ni
⑤	Dielectric	Barium titanate

Item type	Control Code	Dimension [Unit: mm]			
		L	W	T	e
063	A	0.6 ± 0.05	0.3 ± 0.05	0.3 ± 0.05	0.15 ± 0.05

Fig.2 Board / Test Jig of Adhesive force of Terminal Electrodes, Vibration and Thermal Shock

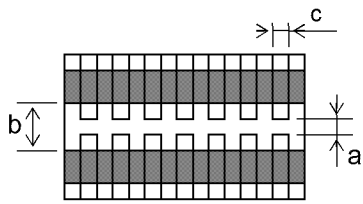

Size (L×W)	a	b	c
0.6×0.3	0.3	0.9	0.3

[Unit: mm]

Material: Glass epoxy board [JIS C 6484]

- Copper foil (thickness: 0.035mm)
- Solder resist

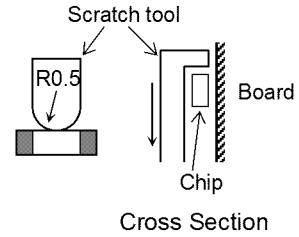

Remarks: Uniform soldering shall be conducted with solder (H60A or H63A in JIS Z 3282) by using soldering iron or soldering oven.
Soldering shall be conducted with care to avoid abnormality such as heat shock.

Fig.3 Test Board

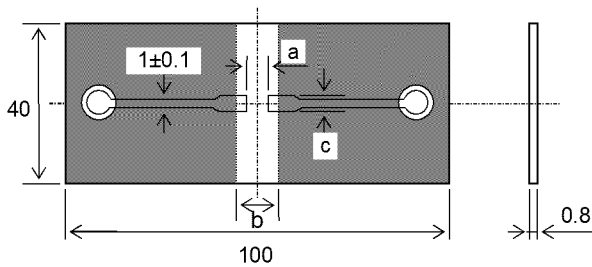

Material: Glass epoxy board [JIS C 6484]

- Copper foil (thickness: 0.035mm)
- Solder resist

Fig.4

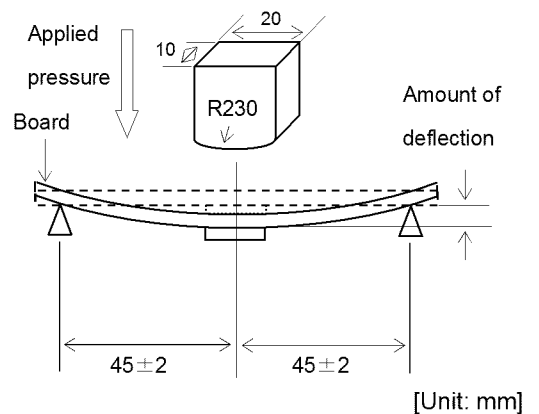

Apply pressure at the rate of 0.5mm/sec. until amount of deflection reaches to 1.0mm.

Size (L×W)	a	b	c
0.6×0.3	0.3	0.9	0.3

[Unit: mm]

Tape Packaging 063 Type

◎Tape packaging type: Paper tape (Press pocket taping)

Dimensions [Unit: mm]

Type	A ※1	B ※1
063	0.37±0.06	0.67±0.06
	0.39±0.06 ※2	0.69±0.06 ※2
	0.44±0.06 ※3	0.74±0.06 ※3

Dimensions [Unit: mm]

C	D	E	F	G	H	J
8.0±0.3	3.5±0.05	1.75±0.1	2.0±0.05	2.0±0.05	4.0±0.1	φ1.5 ^{+0.1} ₋₀

t	t1 ※1
0.45max	0.42max
0.50max ※2	0.45max ※2
0.65max ※3	0.50max ※3

※1: A, B, t1: Sufficient clearance

※2: *MK063A*****F / JDK063ABJ225MP-F

※3: *MK063B*****F

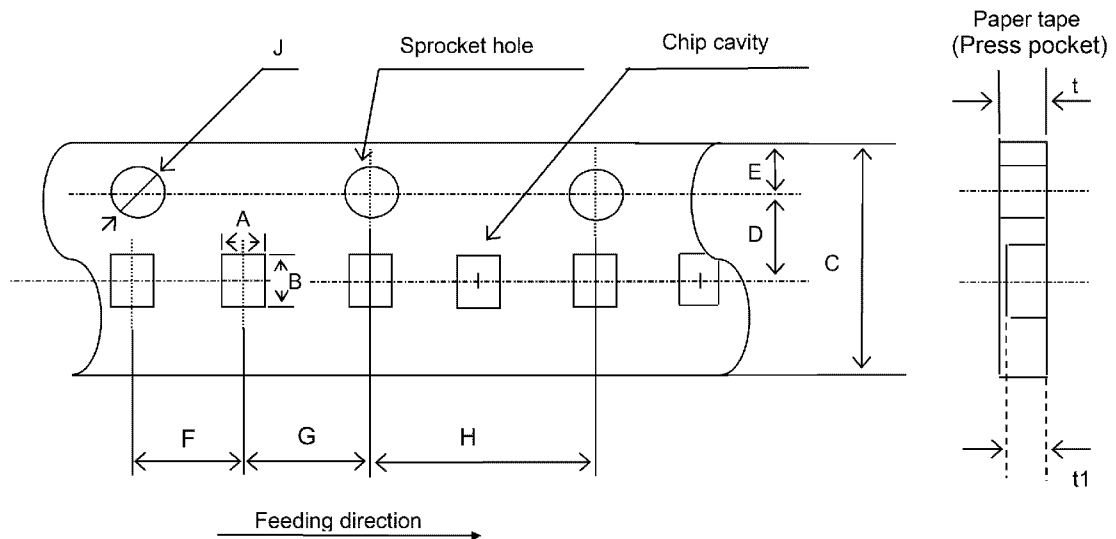

Tape Packaging 063 Type

Dimensions of Reel [Unit: mm]

A	B	C	D	E	W	t	R
$\phi 178 \pm 2.0$	$\phi 50 \text{min.}$	$\phi 13.0 \pm 0.2$	$\phi 21.0 \pm 0.8$	2.0 ± 0.5	10.0 ± 1.5	2.5max.	1.0

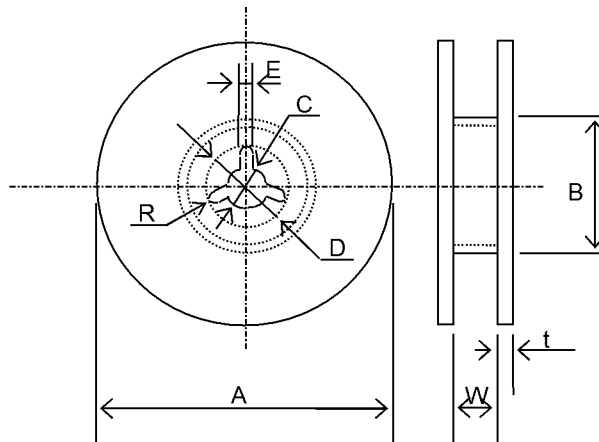

Tape Packaging 063 Type

1. Taping shall be right-sided wound. Sprocket hole shall be on the right side against the pull-out direction.
2. Either the width side (W) or the thickness side (T) of the components faces up at random when the components are inserted in the chip cavities.
3. There shall be blank spaces in each reel tape as shown in the following figure.
 - Leader part 400mm min.
 - Leader part (Blank part) 100mm min.
 - Trailer (Blank part) 160mm min.

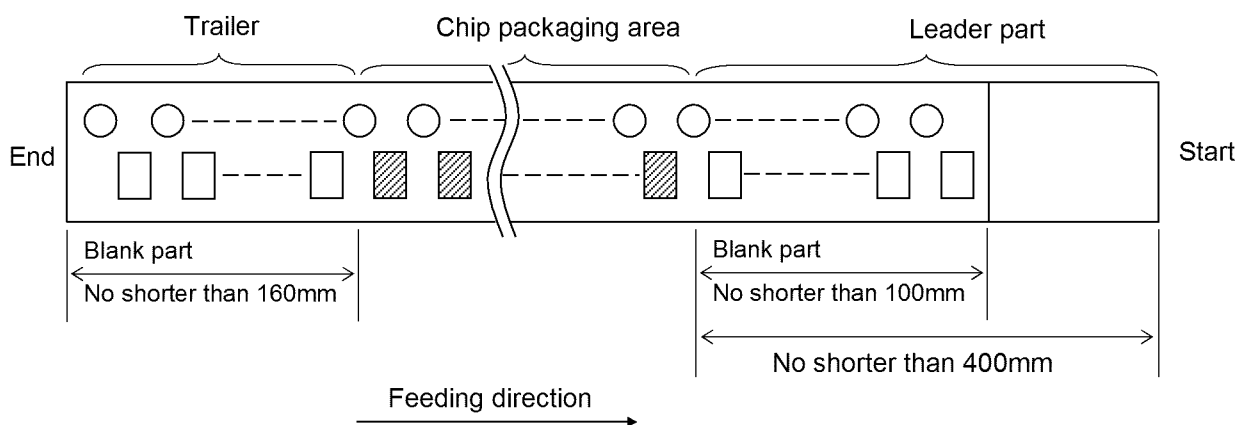

4. Top tape of paper taping shall not be crossed over sprocket holes.
5. Paper tape shall not be seamed.
6. Tensile strength of the tape is 5N (0.51kgf) or over.
7. The number of the chip missing from tape reel shall be 1 piece at a maximum per reel.
8. The number of packaged chips per reel is 15,000 pieces.
9. Label indicating part No., quantity and control No. shall be attached to the outside of reel.
10. Peeling strength of top tape shall be 0.1 to 0.7N (10.2 to 71.4gf) when top tape is peeled from carrier tape at an angle of 0° to 20° .

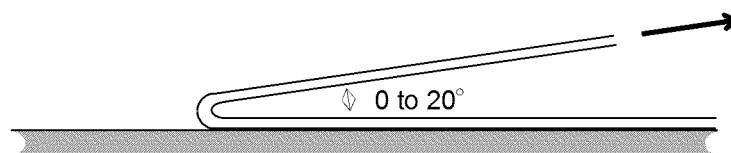

Tape Packaging 063 Type

[Packaging Mode]

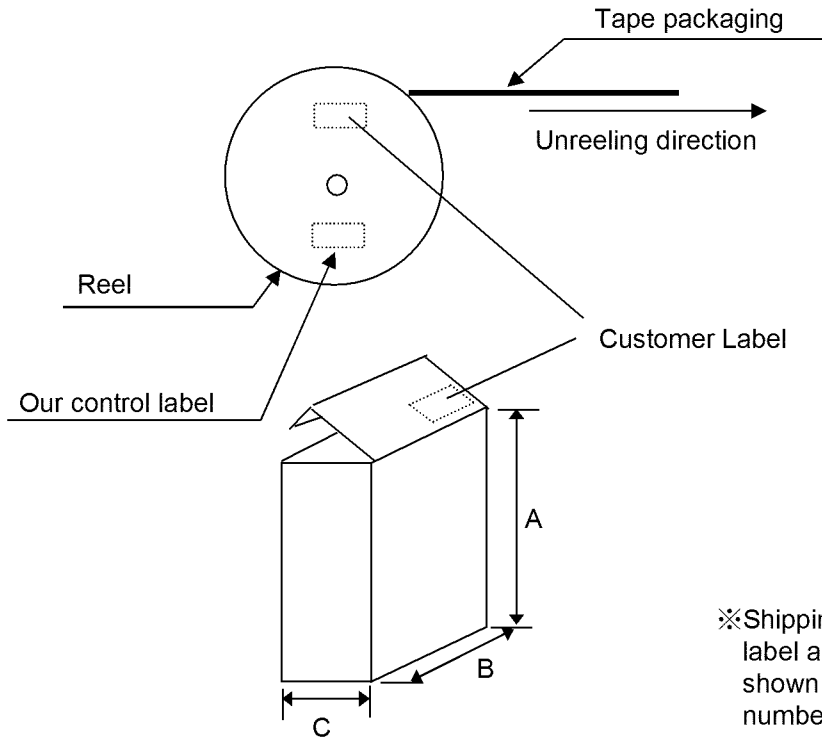

Customer Label contents

1. Manufacture Name
2. Customer Parts No.
3. Our parts no.
4. Quantity
5. Control No.
(Shipping lot number)※
6. Manufacturing site
MADE IN ○○○
7. RoHS

※Shipping lot number is marked on our control label and is also traceable from Control number shown in customer label; no shipping lot number is marked on customer label.

Code	A	B	C	reel
Size	190	185	70	5reel max.
			140	10reel max.

Material: Paper [Unit: mm]

(The size is only for reference.)

Note: Labels are attached on reels/boxes only after components passed all inspections.
Labeled products: Acceptance components

Composition of the shipping lot number

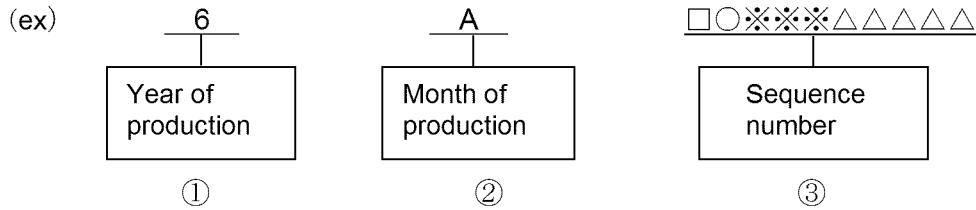

- ① First digit of lot No.: Production year (Last number of the Christian era)
Example: 2016year → 6
- ② Second digit of lot No.: Month of production (See the table below.)
- ③ Sequence number of lot No.: Alphanumeric characters including space

Month	1	2	3	4	5	6	7	8	9	10	11	12
Code	A	B	C	D	E	F	G	H	J	K	L	M

Recommended Soldering Profiles for Lead-free Solder Paste

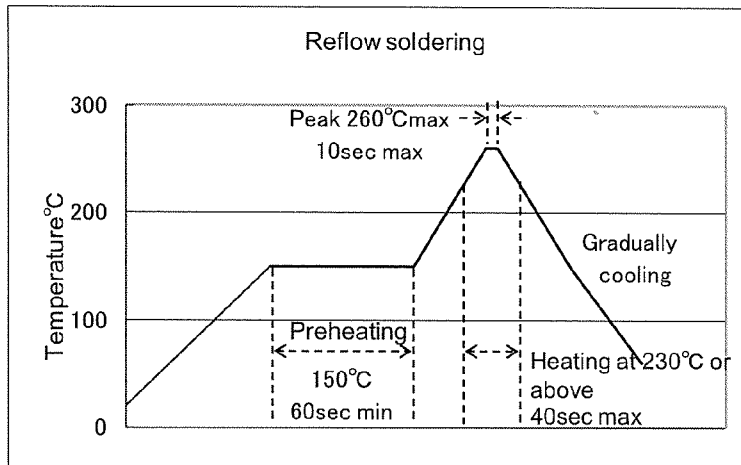

*Ceramic chip component should be preheated sufficiently to maintain the temperature difference between the component surface and solder at 130°C or below.

*Allowable number of reflow soldering: **2 times max.**

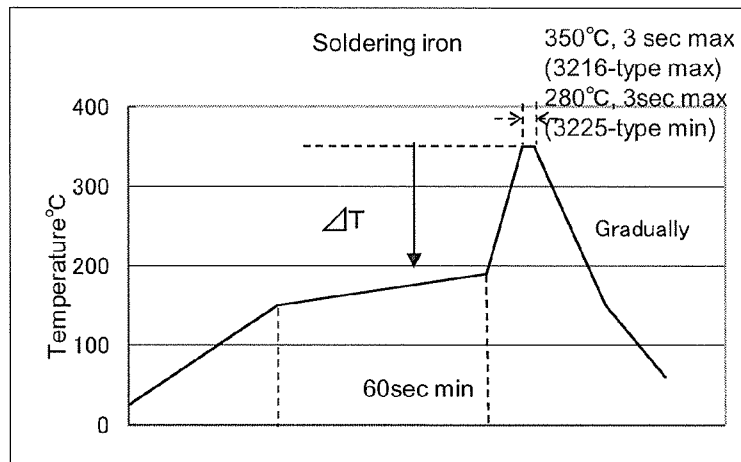

* $\Delta T \leq 150^\circ\text{C}$ (3216-type max), $\Delta T \leq 130^\circ\text{C}$ (3225-type min)

*Preheating control: Boards and components should be preheated sufficiently at 150°C or over, and soldering should be conducted with soldering iron as boards and components are maintained at sufficient temperatures.

*The soldering iron should not directly touch the components.

*Allowable number of hand soldering: **1 time max.**

*Recommendation: Use 20W-soldering iron with the 1φ-tip or less.

Temperature in usage of Pb-free solder (Sn-3Ag-0.5Cu)

Case size	Soldering iron tip temp	Preheating temp.
3216-type max.	$\leq 350^\circ\text{C}$	$\geq 150^\circ\text{C}$
3225-type min.	$\leq 280^\circ\text{C}$	$\geq 150^\circ\text{C}$

**Note: The above profiles are the maximum allowable soldering condition; therefore, these profiles are not always recommended.

TAIYO YUDEN CO.,LTD.

Operating conditions for guarantee of products are as shown in the specification.

Please note that TAIYO YUDEN CO., LTD. shall not be responsible for a failure and/or abnormality which are caused by use under the conditions other than aforesaid operating conditions.

■ All electronic components listed in this specification are developed, designed and intended for use in general electronics equipment(for AV, office automation, household, office supply, information service, telecommunications, [such as mobile phone or PC] etc). Before incorporating the components or devices into any equipment in the field such as transportation, (automotive control, train control, ship control), transportation signal, disaster prevention, medical, public information network(telephone exchange, base station) etc. which may have direct influence to harm or injure a human body, please contact TAIYO YUDEN CO., LTD. for more detail in advance.

Do not incorporate the components into any equipment in fields such as aerospace, aviation, nuclear control, submarine system, military, etc. where higher safety and reliability are especially required. In addition, even electronic components or functional modules that are used for the general electronic equipment, if the equipment or the electric circuit require high safety or reliability function or performances, a sufficient reliability evaluation check for safety shall be performed before commercial shipment and moreover, due consideration to install a protective circuit is strongly recommended at customer's design stage.

■ Please conduct validation and verification of products in actual condition of mounting and operating environment before commercial shipment of the equipment.

■ The contents of this specification are applicable to the components which are purchased from our sales offices or distributors (so called TAIYO YUDEN's official sales channel).

It is only applicable to the components purchased from any of TAIYO YUDEN's official sales channel.

■ Please note that TAIYO YUDEN CO., LTD. shall have no responsibility for any controversies or disputes that may occur in connection with a third party's intellectual property rights and other related rights arising from your usage of products in this specification. Taiyo Yuden Co., Ltd. grants no license for such rights.

■ Caution for export

Certain items in this specification may require specific procedures for export according to Foreign Exchange and Foreign Trade Control Law of Japan, U.S. Export Administration Regulations, and other applicable regulations. Should you have any question or inquiry on this matter, please contact our sales staff.