

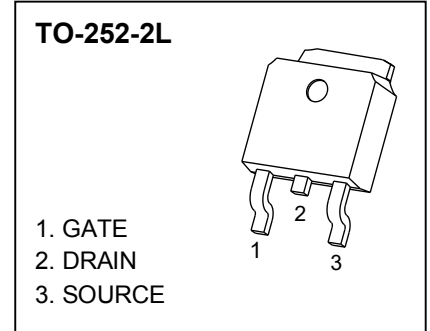

TO-252-2L Plastic-Encapsulate MOSFETS

CJU4828 N-Channel Power MOSFET

$V_{(BR)DSS}$	$R_{DS(on)TYP}$	I_D
60V	37mΩ@10V	4.5A
	60mΩ@4.5V	



DESCRIPTION

The CJU4828 uses advanced trench technology and design to provide excellent $R_{DS(ON)}$ with low gate charge. It can be used in a wide variety of applications.

FEATURES

- High density cell design for ultra low $R_{DS(on)}$
- Fully characterized avalanche voltage and current
- Good stability and uniformity with high E_{AS}
- Special process technology for high ESD capability
- Excellent package for good heat dissipation

APPLICATIONS

- Hard switched and high frequency circuits
- Uninterruptible power supply
- Power switching application

MARKING

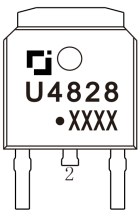

U4828= Device code
 Solid dot = Green molding compound device,
 if none, the normal device
 XXXX=Code

EQUIVALENT CIRCUIT

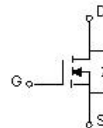

MAXIMUM RATINGS ($T_a=25^{\circ}C$ unless otherwise noted)

Parameter	Symbol	Limit	Unit
Drain-Source Voltage	V_{DS}	60	V
Gate-Source Voltage	V_{GS}	±20	V
Continuous Drain Current	I_D	4.5	A
Pulsed Drain Current	I_{DM}	20	A
Single Pulsed Avalanche Energy	$E_{AS}^{(1)}$	18	mJ
Power Dissipation	P_D	1.25	W
Thermal Resistance from Junction to Ambient	$R_{\theta JA}$	100	$^{\circ}C/W$
Junction Temperature	T_J	150	$^{\circ}C$
Storage Temperature Range	T_{stg}	-55 ~+150	$^{\circ}C$
Lead Temperature for Soldering Purposes(1/8" from case for 10s)	T_L	260	$^{\circ}C$

(1). E_{AS} condition: $V_{DD}=50V, L=0.5mH, R_G=25\Omega$, Starting $T_J = 25^{\circ}C$

Electrical characteristics (T_a=25°C unless otherwise noted)

Parameter	Symbol	Test Condition	Min	Typ	Max	Unit
STATIC PARAMETERS						
Drain-source breakdown voltage	V _{(BR)DSS}	V _{GS} = 0V, I _D =250μA	60			V
Zero gate voltage drain current	I _{DSS}	V _{DS} =60V, V _{GS} = 0V			1	μA
Gate-body leakage current	I _{GSS}	V _{GS} =±20V, V _{DS} = 0V			±100	nA
Gate threshold voltage (note 3)	V _{GS(th)}	V _{DS} =V _{GS} , I _D =250μA	1		3	V
Drain-source on-resistance (note 3)	R _{DS(on)}	V _{GS} =10V, I _D =4.5A		37	56	mΩ
		V _{GS} =4.5V, I _D =3A		60	77	mΩ
Forward tranconductance (note 3)	g _{FS}	V _{DS} =5V, I _D =4.5A	4			S
Diode forward voltage (note 3)	V _{SD}	I _S =1A, V _{GS} = 0V			1	V
DYNAMIC PARAMETERS (note 4)						
Input Capacitance	C _{iss}	V _{DS} =30V, V _{GS} =0V, f =1MHz			540	pF
Output Capacitance	C _{oss}			60		pF
Reverse Transfer Capacitance	C _{rss}			25		pF
SWITCHING PARAMETERS (note 4)						
Turn-on delay time	t _{d(on)}	V _{GS} =10V, V _{DS} =30V, R _L =6.7Ω, R _{GEN} =3Ω		4.7		ns
Turn-on rise time	t _r			2.3		ns
Turn-off delay time	t _{d(off)}			15.7		ns
Turn-off fall time	t _f			1.9		ns
Total Gate Charge (10V)	Q _g	V _{DS} =30V, V _{GS} =10V, I _D =4.5A			10.5	nC
Total Gate Charge (4.5V)					5.5	nC
Gate-Source Charge	Q _{gs}			1.6		nC
Gate-Drain Charge	Q _{gd}			2.2		nC

Notes :

1. The value in any given application depends on the user's specific board design.
2. Repetitive rating : Pulse width limited by junction temperature.
3. Pulse Test : Pulse Width≤300μs, Duty Cycle≤0.5%.
4. These parameters have no way to verify.

Typical Characteristics

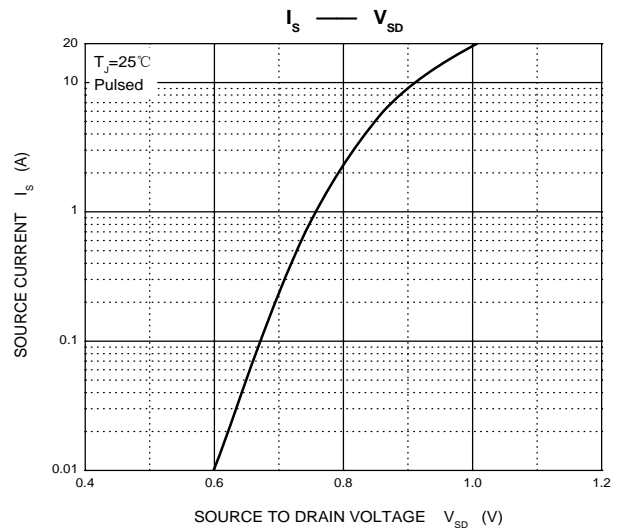
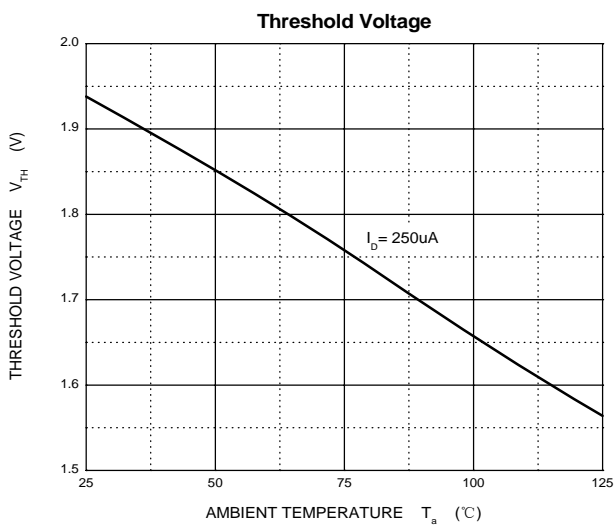
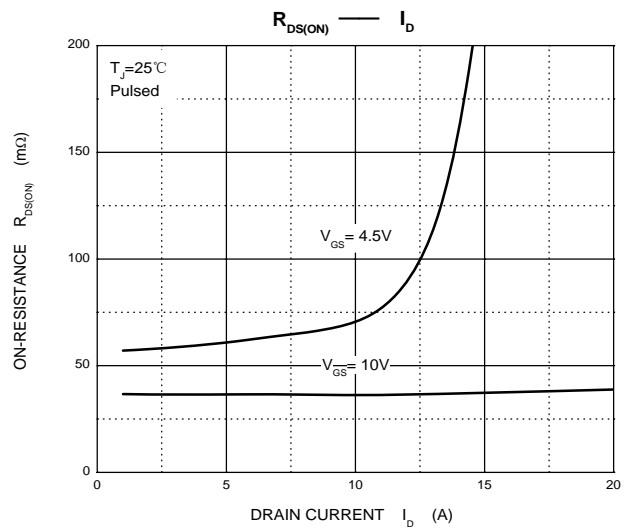
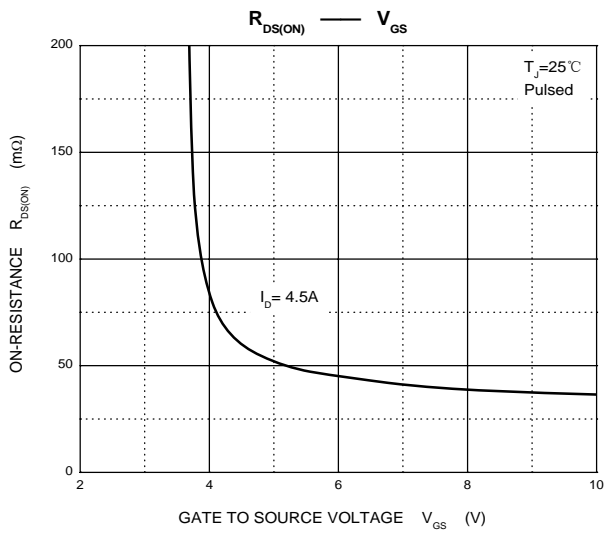
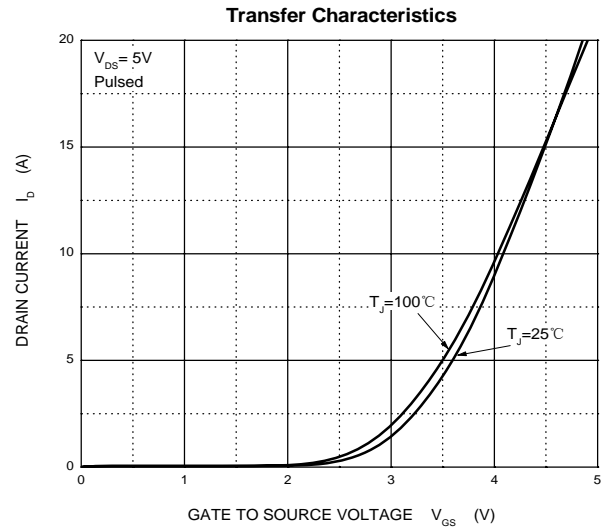
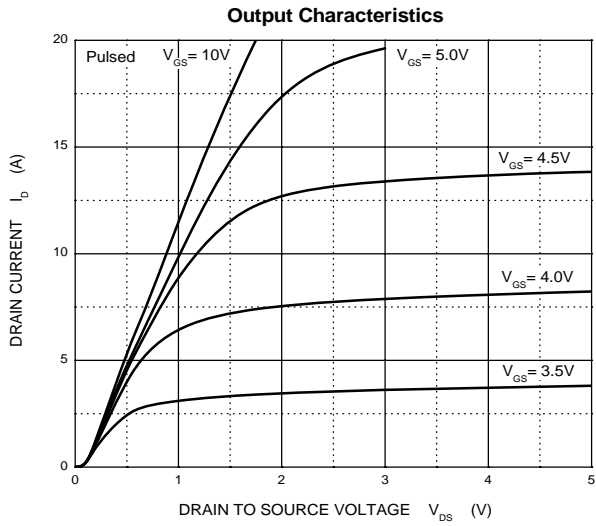

TO-252-2L Package Outline Dimensions

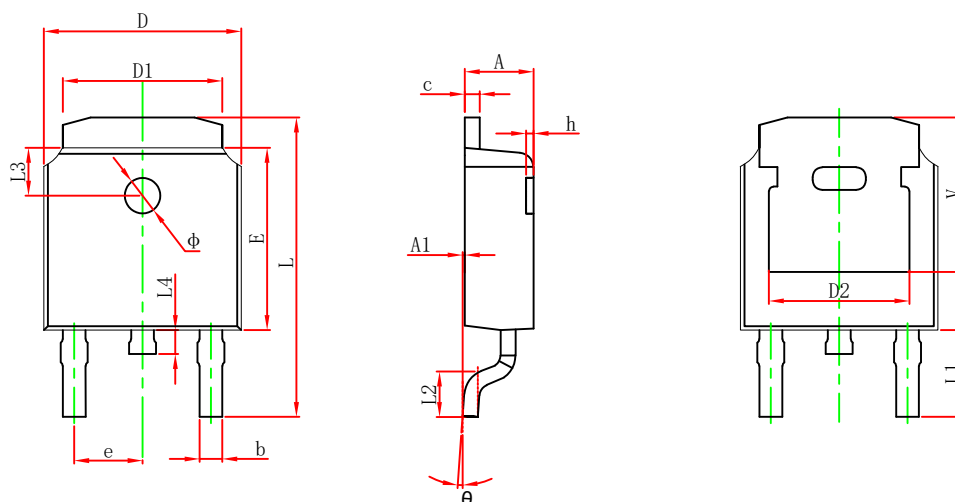

Symbol	Dimensions In Millimeters		Dimensions In Inches	
	Min.	Max.	Min.	Max.
A	2.200	2.400	0.087	0.094
A1	0.000	0.127	0.000	0.005
b	0.635	0.770	0.025	0.030
c	0.460	0.580	0.018	0.023
D	6.500	6.700	0.256	0.264
D1	5.100	5.460	0.201	0.215
D2	4.830 REF.		0.190 REF.	
E	6.000	6.200	0.236	0.244
e	2.186	2.386	0.086	0.094
L	9.712	10.312	0.382	0.406
L1	2.900 REF.		0.114 REF.	
L2	1.400	1.700	0.055	0.067
L3	1.600 REF.		0.063 REF.	
L4	0.600	1.000	0.024	0.039
Φ	1.100	1.300	0.043	0.051
θ	0°	8°	0°	8°
h	0.000	0.300	0.000	0.012
V	5.250 REF.		0.207 REF.	

TO-252-2L Suggested Pad Layout

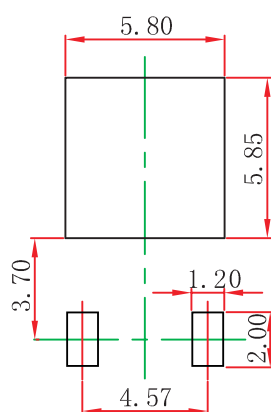

- Note:
1. Controlling dimension: in millimeters.
 2. General tolerance: ± 0.05 mm.
 3. The pad layout is for reference purposes only.

NOTICE

JSCJ reserves the right to make modifications, enhancements, improvements, corrections or other changes without further notice to any product herein. JSCJ does not assume any liability arising out of the application or use of any product described herein.

TO-252-2L Tape and Reel

TO-252 Embossed Carrier Tape

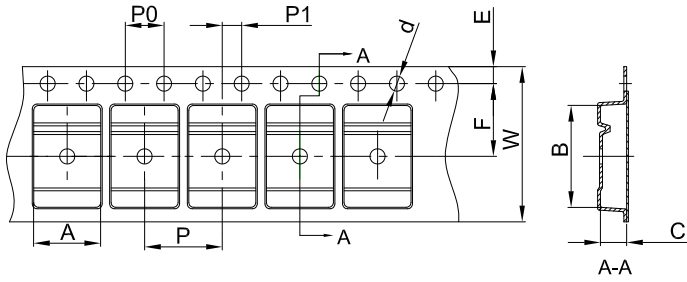

Packaging Description:

TO-252 parts are shipped in tape. The carrier tape is made from a dissipative (carbon filled) polycarbonate resin. The cover tape is a multilayer film (Heat Activated Adhesive in nature) primarily composed of polyester film, adhesive layer, sealant, and anti-static sprayed agent. These reeled parts in standard option are shipped with 25,00 units per 13" or 33.0 cm diameter reel. The reels are clear in color and is made of polystyrene plastic (anti-static coated).

Dimensions are in millimeter										
Pkg type	A	B	C	d	E	F	P0	P	P1	W
TO-252	6.90	10.50	2.70	Ø1.55	1.75	7.50	4.00	8.00	2.00	16.00

TO-252 Tape Leader and Trailer

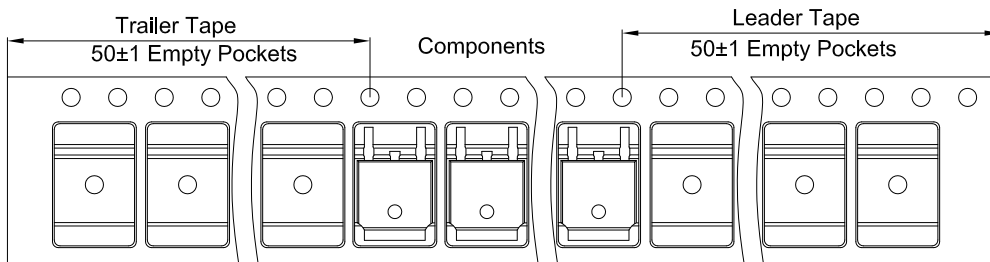

TO-252 Reel

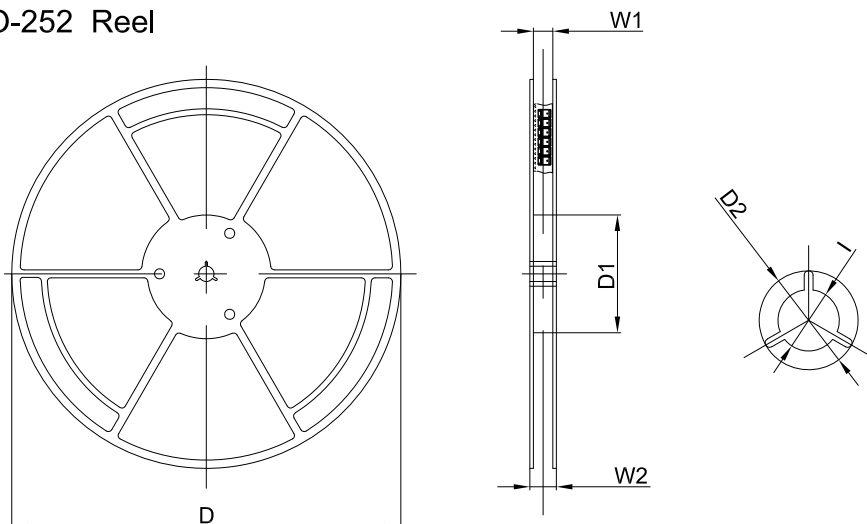

Dimensions are in millimeter						
Reel Option	D	D1	D2	W1	W2	I
13" Dia	330.00	100.00	Ø21.00	16.40	21.00	Ø13.00

REEL	Reel Size	Box	Box Size(mm)	Carton	Carton Size(mm)	G.W.(kg)
2,500 pcs	13inch	2,500 pcs	340×336×29	25,000 pcs	353×346×365	