

Specification:

- 1.Electrical Characteristics:
Contact Current Rating: 5 Amperes FOR VBUS,
1.25 A FOR GND PIN
0.25 A FOR OTHER

- Rated Voltage: 20V Max.
- Dielectric Withstanding Voltage: AC 100V r.m.s.
- Insulation Resistance: 100 MΩ Minimum.
- Contact Resistance: 40 mΩ Maximum.

- 2.Environmental:
Operating Temperature: -40°C~+85°C.

- 3.Mechanical Characteristics:
Insertion Force: 5~20Nf.
Withdrawal Force: 6~20Nf.
Durability Cycles: 3000 Cycles.

- 4. Make is FAI test Dimension
 Make is major test Dimension

A5	CC1	B5	CC2
A9	VBUS	B9	VBUS
A12	GND	B12	GND
PIN	SIGNAL NAME	PIN	SIGNAL NAME

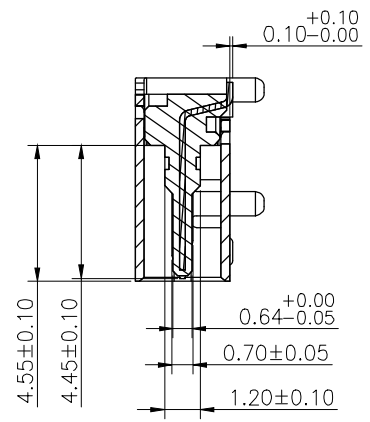
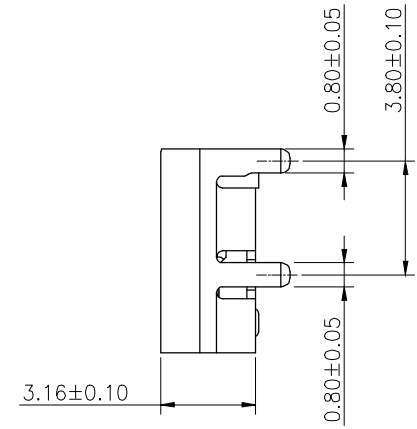
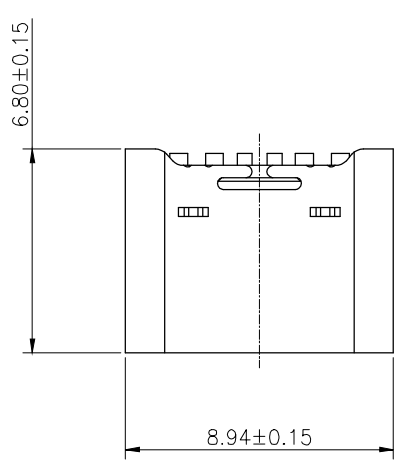

Section:A-A

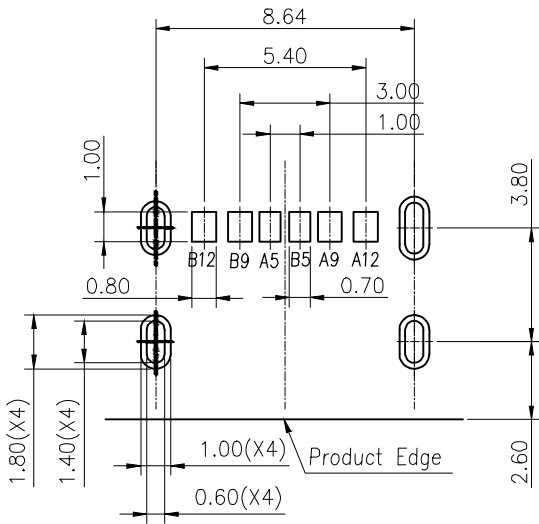

RECOMMENDED P.C.B. LAYOUT
TOLERANCE UNSPECIFIED ±0.05mm

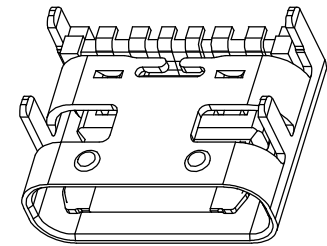
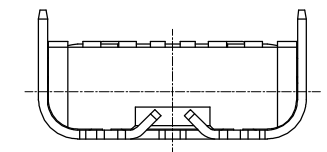
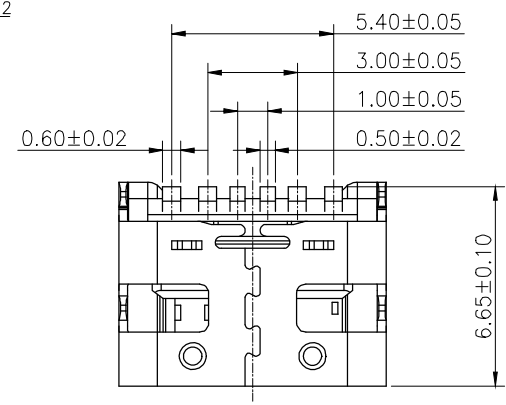
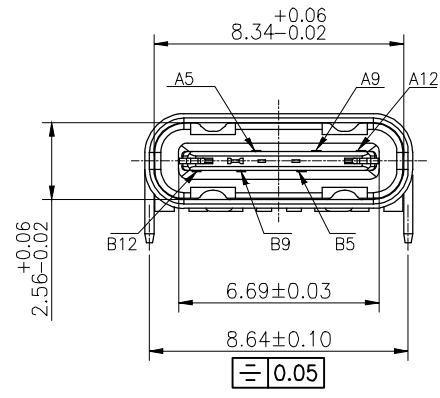

HADFU ELECTRONICS TECHNOLOGY
CO.,LTD

COPYRIGHT RESERVED,PLEASE DO NOT COPY.

PART NAME		CONNECTOR		DRAWING		Y,C,ZHANG		DWG.No.		SBICL	
PART NO.		TYPE-C 2.0 6PIN		CHECK		G.C.Chen		REV.		A1	
UNIT : mm	TOLERANCE OTHERWISE	UP TO 5 ±0.2	ABOVE 5~30 ±0.3	ANGLE	APPROVAL		DATE		14-03-2013		
					SCALE		PAGE		1 OF 1		

文件履历表						
No.	Date	Document No.	Prepared	Checked	Approved	Summary
<p>Product specification</p> <p>产品规格书</p>						
Product Name			Part Number.		Rev.	
USB3.1 C TYPE CONNECTOR,			/		A	

- 1; SCOPE (适用范围)
- 2; REFERENCE DOCUMENTS (参考文件)
- 3; FEATURE & DIMENSIONS (特征及尺寸)
 - 3.1. PRODUCT DIMENSION (产品尺寸)
 - 3.2. PCB/PANEL LAYOUT (印刷电路板布局)
 - 3.3. MATERIAL (材料)
 - 3.4. MECHANICAL & ELECTRICAL CHARACTERISTIC (机械及电气特性)
 - 3.5. PACKAGING (包装)
 - 3.6. TRANSPORTATION (运输)
 - 3.7. STORAGE (存贮)
4. ENVIRONMENTAL (环境要求)
 - 4.1. SOLDERABILITY (可焊性)
 - 4.2. RESISTANCE TO SOLDER HEAT (耐焊接热)
 - 4.2.1. Wave Soldering (波峰焊)
 - 4.2.1.1. Preheat (预热)
 - 4.2.1.2. Soldering (焊接)
 - 4.2.1.3. Cool Down (冷却)
 - 4.2.2. INFRARED REFLOW (红外线回流焊)
 - 4.2.2.1. Preheat (预热)
 - 4.2.2.2. Soldering (焊接)
 - 4.2.2.3. Cool Down (冷却)
 - 4.3. CLEANING (清洗)
5. PERFORMANCE AND TEST DESCRIPTION (性能及测试)
 - 5.1. REQUIREMENT (要求)
 - 5.2. TEST CONDITION (测试条件)
 - 5.3. SAMPLE SELECTION (样品选择)
 - 5.4. TEST SEQUENCE (测试顺序)
6. QUALITY ASSURANCE PROVISIONS (品质保证)

TABLE I: PRODUCT QUALIFICATION TEST SEQUENCE

TABLE II: REFLOW SOLDERING PROFILE

1. SCOPE (适用范围)

This product specification specifies the characteristics and test methods of USB 3.1 series "C type" connectors designed and produced by yifeng.

本产品规格书规定了由意丰设计生产的 **USB 3.1 系列“C 型”** 连接器产品的特性及测试方法。

2. REFERENCE DOCUMENTS (参考文件)

MIL-STD-1344A Test method for electrical connector (电子连接器测试方法)

MIL-STD-202F Test method for electrical components (电子零件测试方法)

EIA364 Test method for electrical components (电子零件测试方法)

JIS C 0051 Test method for electrical components (电子零件测试方法)

MIL-G-45204C Specification for gold plating (镀金规格)

IEC-512-3 IEC standard for current carrying capacity tests (IEC电流测试标准)

QQ-N-290A Specification for nickel plating (镀镍规格)

MIL-P-81728A Specification for tin/lead plating (镀锡铅规格)

MIL-T-10727B Specification for tin plating (镀锡规格)

UL498 UL standard for safety of attachment plug and receptacle (UL安规要求标准)

EN/ISO5961 Determination of total lead & cadmium content (总铅和总镉含量测定)

EN1122 Determination of total lead & cadmium content (总铅和总镉含量测定)

EN13346 Determination of heavy metals content (重金属含量测定)

EPA3052 Determination of total lead & cadmium content (总铅和总镉含量测定)

3. FEATURE & DIMENSIONS (特征及尺寸)

3.1. PRODUCT DIMENSION (产品尺寸)

These connectors shall have the dimensions as shown in customer drawing.

本产品的相关尺寸参见客户图面。

3.2. PCB/PANEL LAYOUT (印刷电路板布局)

The recommended PCB layout is shown in customer drawing.

本产品适用的PCB layout参见客户图面。

3.3. MATERIAL (材料)

The harmful material can follow the requirement of RoHS.

本产品使用的材料符合 RoHS 指令要求。

3.4. MECHANICAL & ELECTRICAL CHARACTERISTIC (机械及电气特性)

The connector shall have the mechanical and electrical performance as described in table I:

本产品的机械及电气特性见附表I。

3.5. PACKAGING (包装)

This product adopts tray or REEL package

本产品采用tray 盘或REEL包装,

3.6. TRANSPORTATION (运输)

Any vehicle can be adopted for the transportation, but moisture-proof and no mechanical damage.

可采用任何运输工具运输, 勿淋湿及机械性损伤。

3.7. STORAGE (存贮)

Temperature: $-25^{\circ}\text{C}\sim+85^{\circ}\text{C}$, Relative humidity: $\leq 80\%$, Not to storage in corrosive environments A re-qualification test shall be conducted immediately while the storage duration exceed 6 months.

温度: $-25^{\circ}\text{C}\sim+85^{\circ}\text{C}$; 相对湿度: $\leq 80\%$; 勿贮存于腐蚀环境内。贮存期超过6个月后需重新进行品质确认。

4. ENVIRONMENTAL (环境要求)

4.1. SOLDERABILITY (可焊性)

Connector's solderability can meet MIL-STD-202F standard. Finish shall be free of contaminants.

产品可焊性符合 MIL-STD-202F 标准规定的相关要求, 表面不得有污染物。

4.2. RESISTANCE TO SOLDER HEAT (耐焊接热)

4.2.1. Wave Soldering (波峰焊)

Consists of three consecutive phases. 包括三个连续的阶段完成;

4.2.1.1. Preheat (预热)

Increase in temperature not to exceed 4°C per second. Final preheat temperature will be within 125°C of solder temperature. 温度增加不超过 4°C /秒, 最终预热温度不超过 125°C 。

4.2.1.2. Soldering (焊接)

Device leads will be exposed to solder wave at 250°C for a maximum of 5 seconds. 设备中的引导焊接温度最高 250°C 不超过5秒。

4.2.1.3. Cool Down (冷却)

Cool down in ambient air at approximately 20°C to 25°C . 冷却到周围环境温度 $20^{\circ}\text{C}\sim 25^{\circ}\text{C}$ 。

4.2.2. INFRARED REFLOW (红外线回流焊)

Three cycles. Each cycle consisting of three consecutive phased. 三个周期, 每个周期包括三个连续的阶段完成;

4.2.2.1. Preheat (预热)

Increase in temperature not to exceed 4°C per second. 温度增加不超过 4°C /秒,

4.2.2.2. Soldering (焊接)

Maximum allowable time above reflow temperature of 183°C is 90 seconds. Maximum temperature in this interval is 250°C , not to exceed 10 seconds. 回流焊温度 183°C 以上的时最长不超过 90秒。最高温度 250°C 时间不超过10秒。

4.2.2.3. Cool Down (冷却)

Cool down shall not exceed 6°C per second. 冷却速度不超过 6°C /秒。 **Note:** (注) Device temperature measurements are referenced from the top-center of the package outer surface. 设备温度量测时以从顶部中间位置测量为准;

4.3. CLEANING (清洗)

Connectors resist to cleaning process. Aqueous Cleaning: Three cycles; each cycle consisting of a

maximum of one minute exposure to 54°C to 66°C dematerialized tap water at a maximum pressure of 30 psi; followed by air drying for 60°C to 90 seconds at 93°C to 121°C.

产品本身可以承受清洗制程。水洗：包含三个循环，每个循环包括以下：以最大压力30帕，温度 54°C~66°C，去除矿物质的水，用水龙头冲洗最多一分钟，然后用温度 93°C~121°C的空气吹60到90秒；

5. PERFORMANCE AND TEST DESCRIPTION (性能及测试)

5.1. REQUIREMENT (要求)

Product is designed to meet electrical, mechanical, and environmental performance requirements specified in **Table I**.

本产品设计符合附表一所述的机械，电气及环境要求。

5.2. TEST CONDITION (测试条件)

Unless otherwise specified, all tests shall be performed at ambient environmental conditions. 除非特别注明，所有测试在室温条件下完成；

5.3. SAMPLE SELECTION (样品选择)

Test samples shall be selected at random from current production. No test samples shall be reused.

Samples are pre-conditioned with 10cycles of durability. Each group shall be containing 5 test samples.

测试样品从现生产的产品中随机抽取，所有测试过的样品不得重复使用。样品已预先插拔10次，每组测试有5个样品；

6. QUALITY ASSURANCE PROVISIONS (品质保证)

The company is responsible for the quality of all products sent to customers, and the defective batches are returned or corrected by the supplier

本公司对于出给客户的所有产品品质负责，不良批次的产品退回或由供应商做矫正；

TABLE I: PERFORMANCE REQUIREMENTS

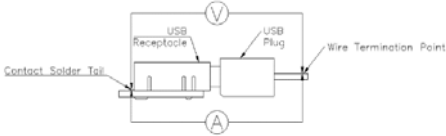
TABLE I: PERFORMANCE REQUIREMENTS		
Items	Requirements	Test Methods
1	Confirmation of Product 产品确认 Product shall be conforming to the requirements of applicable product drawing 产品必须满足相关文件的规定	Visually dimensions and functionally inspected per applicable product drawing. 目视尺寸及功能依照客户图面检查
Electrical Requirement		
Items	Requirements	Test Methods
2	Low level Contact resistance 低电平接触阻抗 1. 40 mΩ (Max) initial for VBUS, GND and all other contacts. 2. Maximum change (delta) of +10 mΩ after environmental stresses. 1.电源 PIN、接地 PIN 及其它 PIN 脚接触阻抗均为 40mΩ 最大。 2.产品阻抗变化值不超过 10mΩ。 	The low level contact resistance measurement is made from the solder tail of the receptacle to the soldering point of the plug. when measured at 20mV Max. open circuit at 100mA. Mated test contacts must be in a connector housing. Test reference standard: EIA-364-23B 接触阻抗测量方式从母头的焊脚处至公头的焊脚处。 在开路最大电流为 100mA 电压为 20mV 情况下测试胶芯插入时端子之间接触处的阻抗值。 测试参考标准: EIA 364-23B
3	Insulation Resistance 绝缘阻抗 100 MΩ Min. 100 MΩ 最小	Test between adjacent circuits Insulation Resistance of unmated and mated connectors. Test reference standard: EIA 364-21. 测试对插的连接器两个相邻端子之间的绝缘阻抗值。 测试参考标准: EIA 364-21
4	Dielectric Strength 耐电压 No breakdown shall occur. 产品不能出现衰竭、损坏现象。	when 100 Volts AC (RMS) is applied between adjacent contacts of unmated and mated connectors. Test reference standard: EIA-364-20. 使用 100V 交流电压测试公母头插入与拔出时相邻端子之间的承受电压情况。 测试参考标准: EIA 364-20

5	Contact current rating 温升	<p>1.A current of 3.0 A shall be applied collectively to VBUS pins (pins A4, A9, B4, and B9)</p> <p>2.1.25 A applied to the VCONN pin (B5 of the plug connector) with the return path through the corresponding GND pins (pins A1, A12, B1, and B12).</p> <p>3. A minimum current of 0.25 A shall also be applied individually to all the other contacts.</p> <p>1.VBUS pins 需通过电流5.0A(pin A4, A9, B4, and B9)。</p> <p>2. VCONN pin(公头B5 pin)及GND pins需通过电流1.25A(pins A1, A12, B1, and B12)。</p> <p>3.其余pins需通过最小电流0.25A。</p>	<p>When the currents are applied to the contacts, the temperature rise shall not exceed 30 °C at any point on the USB Type-C mated plug and receptacle under test, when measured at an ambient temperature of 25 °C.</p> <p>Test reference standard: EIA -364-70 method B</p> <p>在相对温度为25℃，当电流通过USB C type公母头连接器时，测试连接器中端子任一点温度不超过+30℃。</p> <p>测试参考标准：EIA 364-70 方法B</p>
---	------------------------------	--	--

Mechanical Requirement

	Items	Requirements	Test Methods
6	Insertion Force 插入力	<p>The initial connector insertion force shall be within the range from 5 N to 20 N.</p> <p>连接器初始插入力需在 5N~20N 范围内。</p>	<p>Measure the force required to mate connector, At a maximum rate of 12.5mm(0.492") per minute.</p> <p>Test reference standard: EIA-364-13</p> <p>测试的力必须是相匹配的连接器，插入速度不超过每分钟 12.5mm。</p> <p>测试参考标准：EIA 364-13</p>
7	Extraction Force 拔出力	<p>The initial connector Extraction force shall be within the range from 8 N to 20 N.</p> <p>连接器初始拔出力需在 8N~20N 范围内。</p>	<p>Measure the force required to mate connector, At a maximum rate of 12.5mm(0.492") per minute.</p> <p>Test reference standard: EIA-364-13</p> <p>测试的力必须是相匹配的连接器，拔出速度不超过每分钟 12.5mm。</p> <p>测试参考标准：EIA 364-13</p>
8	Durability or Insertion/extraction Cycles 耐久或插入拔出次数	<p>The durability rating shall be 10,000 cycles minimum.</p> <p>耐久测试最小 10000 次。</p>	<p>The durability test shall be done at a maximum rate of 200 cycles per Hour and no physical damage to any part of the connector and cable assembly shall occur.</p> <p>Test reference standard:EIA-364-09</p> <p>耐久测试速度不超过每小时 200 个循环，且测试后的产品及线材本身任何部位不能出现损坏。</p> <p>测试参考标准：EIA 364-09</p>

9	Physical Shock 物理冲击	No breakdown shall occur. 产品不能出现损坏现象。	No discontinuities of 1 μ s or Longer duration. when mated USB C type connectors are subjected to 11ms duration 30Gs half-sine shock pluses. Three shocks in each direction applied along three mutually perpendicular planes for a total of 18 shocks. Test reference standard: EIA 364-27 Test Condition H. 匹配USB C TYPE 连接器, 中断不得大于或等于1 μ s, 30Gs的半波脉冲承受11ms, 从三个正交的方向施加冲击, 总冲击次数为18次。
---	------------------------	--	--

Environmental Requirements

Items	Requirements	Test Methods
10	Humidity 恒温恒湿	Temperature: 25~65 $^{\circ}$ C, Relative humidity: 90-95%, Duration: 96Hours, Circulate test: 10 Cycles. Test reference standard: EIA 364-31 温度: 25~65 $^{\circ}$ C, 相对湿度: 90-95%, 持续时间: 96 小时, 循环测试: 10次 测试参考标准: EIA 364-31。
11	Thermal shock 冷热冲击	Temperature range from -55 $^{\circ}$ C to +85 $^{\circ}$ C .Start from -55 $^{\circ}$ C. After 30 min. change to +85 $^{\circ}$ C, change time is no more than 30 seconds. Total 5 cycles. Test reference standard: EIA 364-32 温度变化范围: -55 $^{\circ}$ C ~ +85 $^{\circ}$ C, 从-55 $^{\circ}$ C开始, 30分钟后换到+85 $^{\circ}$ C; 转换时间不超过30秒; 共5 个循环。 测试参考标准: EIA 364-32
12	Hot air reflow or IR reflow for SMT curing process SMT 热风回流焊	Place subjected connector on the PCB Board and expose them to the reflow oven and apply the following condition: Room 1: preheat temperature 150 $^{\circ}$ C - 170 $^{\circ}$ C for 100 seconds. Room 2: preheat temperature 170 $^{\circ}$ C - 200 $^{\circ}$ C for 100 seconds. Room 3: reflow temperature 200 $^{\circ}$ C -

			<p>260°C for 120-60 seconds. (For 260°C ONLY 5-10 seconds) 将产品放在PCB板上,然后放入回焊炉中并用于以下条件: 时间段1: 预热温度150°C-170°C 100秒。 时间段2: 预热温度170°C - 200°C 100秒。 时间段3: 回焊炉温度200°C - 260°C 100秒。(260°C 时间仅5~10S)</p>
13	<p>Solderability 可焊性</p>	<p>The inspected area of each lead must have 95% solder coverage Minimum. 检测焊接端的锡覆盖率需大于95%</p>	<p>Solder pot temperature: 250±5°C Soldering time: 3 to 5 Seconds Test reference standard: EIA 364-52 锡炉温度: 250±5°C, 焊接时间: 3~5 秒 测试参考标准: EIA 364-52。</p>
14	<p>Salt Spray 盐雾测试</p>	<p>Shall meet visual requirements, No detrimental corrosion allowed in contact area and base metal exposed. 产品外观良好, 端子及外壳金属无生锈、腐蚀及露底材不良。</p>	<p>Subject mated connectors to 35+/-2 °C and 5+/-1% salt condition for 24 hours. After test, rinse the sample with water and recondition the room temperature for 1 hour. Test reference standard:EIA-364-26B. 测试的连接器需放于温度35±2°C, 盐水浓度(重量比)5±1%的容器中测试24小时。测试后的产品使用清水冲洗后放入常温下1小时。 测试参考标准: EIA 364-26。</p>

TABLE II:

REFLOW SOLDERING PROFILE

Pb-free reflow profile requirements:

Parameter	Reference	Specification
Average temperature gradient in preheating		2.5°C/s
Soak time	T soak	2-3 minutes
Time above 217°C	t1	60 s
Time above 230°C	t2	50 s
Time above 250°C	t3	5 s
Peak temperature in reflow	T peak	260°C (+/-5°C)
Temperature gradient in cooling		Max -5°C/s

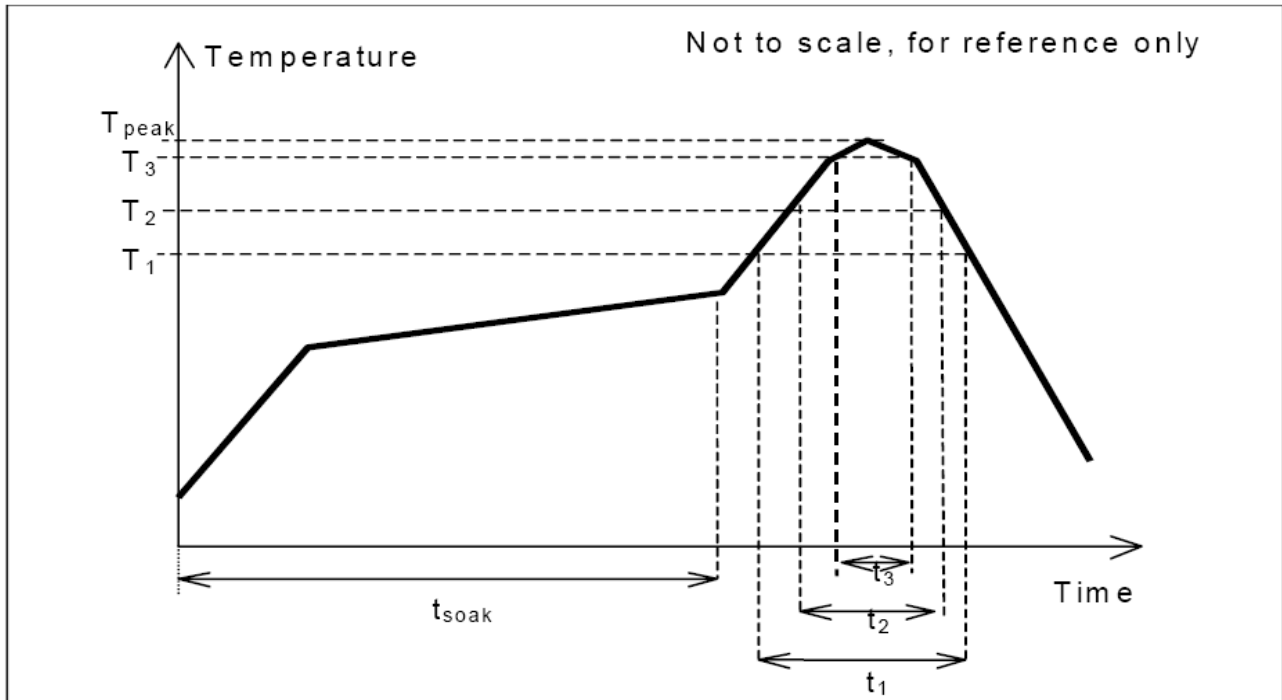

This profile is the minimum requirement for evaluating soldering heat resistance of components. Heat transfer method used for reflow soldering is hot air convection. The actual air temperatures used to achieve the specified profile is higher and largely dependent on the reflow equipment.