

← F
← E
← D
← C
← B
← A

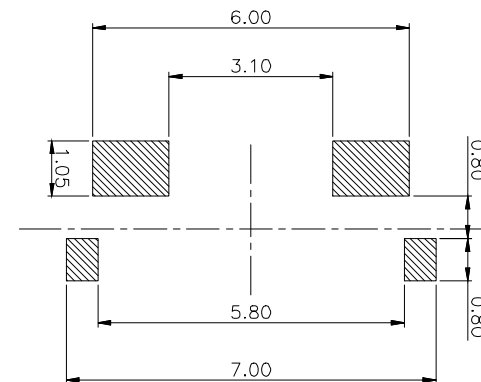
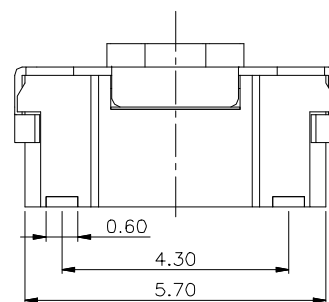
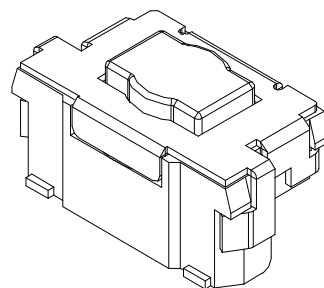

安装参考图

主要技术规格:

1. 额定值: 50mA DC12V
2. 接触电阻: 100mΩ
3. 操作力: 160gf
4. 行程: 0.2+0.1mm
5. 绝缘电阻: 100MΩ
6. 抗电强度: 250V 50HZ 1Min.
7. 寿命: 10万Cycles

材料:

- A卡 件: 磷铜 (镀银)
- B底座: LCP (黑色)
- C簧 片: 不锈钢 (镀银)
- D内薄膜: 进口聚酰亚胺 (黄色)
- E盖 板: 磷铜 (镀银)
- F按 钮: LCP (白色)

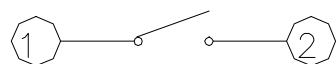

电路图

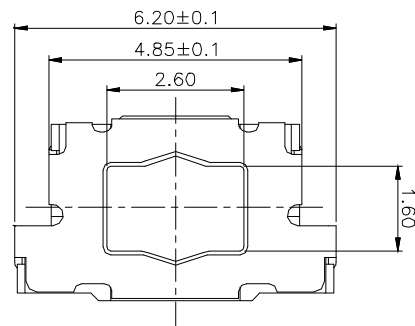
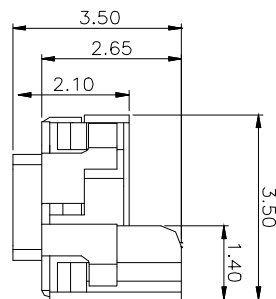

HAOFU ELECTRONCS TECHNOLOGY CO.,LTD

COPYRIGHT RESERVED,PLEASE DO NOT COPY.

PART NAME		TACT SWITCH		DRAWING		Y,C,ZHANG		DWG.No.		SBICL	
PART NO.		TD-601XB		CHECK		G.C.Chen		REV.		A1	
UNIT :	TOLERANCE OTHERWISE	UP TO 5	±0.2	ANGLE	APPROVAL	DATE	PAGE	1 OF 1			
		ABOVE 5~30	±0.3								
mm		ABOVE 30	±0.5	0°±3'	SCALE	2:1					

TACT SWITCH SPECIFICATION(轻触开关说明书)

1. General specification 基本说明

1.1 Scope 范围 This specification covers the requirements for single key switches which have no keytop (TACT SWITCHES:MECHANICAL CONTACT). 此规范含盖单推柄和无推柄的轻触开关要求。

1.2 Operating Temperature Range 使用温度范围
-20 to 70 °C(normal humidity, normal press).正常湿度，标准压力

1.3 Storage Temperature Rang 保存温度范围
-40 to 85 °C(normal humidity, normal press).

1.4 Test Conditions 测试条件

Tests and measurements shall be made in the following standard cnditions unless otherwise specified:

测试和计量按下列标准条件除非特殊说明

Normal temperature (temperature 5 to 35°C) 标准温度

Normal humidity (relative humidity 45 to 85%) 正常湿气

Normal pressure (pressure 860 to 1060 mbars) 标准压力

In case any question arises from the judgement made, tests shall be conducted in the following conditions:

Temperature (20±2°C) 温度

Relative humidity (65±5%) 相对湿度

Pressure (860 to 1060 mbars) 压力

2. APPEARANCE, STYLE, AND DIMENSIONS 外形，类型和尺寸

2.1 Appearance 外形

There shall be no defects that affect the serviceability of the product 外形必须无缺陷才不影响产品适用性

2.2 Style and Dimensions 类型和尺寸

Shall conform to the assembly drawings. 符合装配图

3. TYPE OF ACTUATION 动作类型

Tactile feedback 轻触返回

4. CONTACT ARRANGEMENT 1 poles 1 throws 接触形式 1 接点 1 回路

(Details of contact arrangement are given in the assembly drawings).

细接点形式在装配图中

5. MAXIMUM RATINGS DC 12 V 50 mA 最大额定值

6. MINIMUM RATINGS DC 1 V 10 μA 最小额定值

						APPD	CHKD	DSGD	TD-601XB 160g
ZONE	SYMB	DATE	APPD	CHKD	DSGD				1/7

TACT SWITCH SPECIFICATION(轻触开关说明书)

6.2 Mechanical 机械特性

Item 项目	Test Condition 试验条件	Requirements 规格
6.2.1. Actuating Force 动作力	Placing the switch such that the direction of switch operation is vertical and then gradually increasing the load applied to the center of the stem, the maximum load required for the stem to come to a stop shall be measured. 开关的动作方向为垂直放置开关向推柄中心逐渐增加负荷直到推柄停止时所测量的最大负荷	160±30gf
手感值	过回流焊 270℃后用曲线仪测试手感	40%-60%
6.2.2. Travel 行程	Placing the switch such that the direction of switch operation is vertical and then applying a static load twice the actuation force to the center of the stem, the travel distance for the stem to come to a stop shall be measured. 开关的动作方向为垂直放置开关，在已有行程的推柄中心向上减小压力，推柄回到自由位置时所测到的力	0.15±0.05mm
6.2.3. Return Force 返回力	The sample switch is installed such that the direction of switch operation is vertical and, upon depression of the stem in its center the whole travel distance ,the force of the stem to return to its free position shall be measured. 开关的动作方向垂直放置开关，在已有行程的推柄中心向上减小压力，推柄回到自由位置时所测量到的力	30gf min
6.2.4. Stop Strength 静止强度	Placing the switch such that the direction of switch operation is vertical, a static load of <u>3</u> kgf shall be applied in the direction of stem operation for a period of <u>60</u> seconds. 开关的动作方向为垂直放置开关，在推柄动作方向施加 3 KG 的静负荷，60 秒时间	There shall be no sign of damage mechanically and electrically 无机械的和电气的损伤迹象
6.2.5. Stem Strength 推柄的强度	Placing the switch such that the direction of switch operation is vertical, the maximum force to withstand a pull applied oppsite to the direction of stem operation shall be measured. 开关的动作方向为垂直放置开关从推柄动作方向反方向施加拉力所测量到的最大承受力	3 kgf
	APPD CHKD DSGD	TD-601XB 160g
2/7		
ZONE SYMB DATE APPD CHKD DSGD		

TACT SWITCH SPECIFICATION(轻触开关说明书)

6.PERFORMANCE 性能

6.1 Electrical 电气

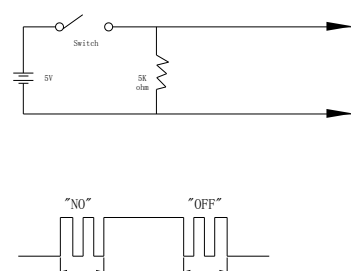
Item 项目	Test Condition 试验条件	Requirements 要求
6.1.1. Contact Resistance 接触电阻	Applying a static load twice the actuating force to the center of the stem, measurements shall be made with a 1 kHz small-current contact resistance meter. 用两倍的动作用力作静负载施加于按钮的中心, 并用 1 千赫小电流接触电阻仪测量	<u>50</u> mΩmax.
6.1.2. Insulation Resistance 绝缘电阻	Measurements shall be made following application of DC 100 V potential across terminals and across terminals and frame for one minute. 在端子之间, 端子与外壳之间施加 DC100V, 一分钟	<u>100</u> MΩmin
6.1.3. Dielectric Withstanding voltage 电气耐压	AC250V (50Hz or 60Hz) shall be applied across terminals and across terminals and frame for one minute. 在端子与端子之间, 端子与外壳之间施加 AC250V(50Hz or 60Hz)	There shall be no breakdown 没有击穿
6.1.4. Bounce 抖动	Lightly striking the center of the stem at a rate encountered in normal use (3 to 4 operations per sec), Bounce shall be tested at "ON" and "OFF" 在正常使用中(以每秒 3-4 次周期)轻轻地在手柄中心加力, 在通与断瞬间测试抖动。 <div style="text-align: center; margin-top: 10px;">  </div>	<u>20</u> m sec max .

						APP	CHKD	DSGD	TD-601XB 160g
ZONE	SYMB	DATE	APPD	CHKD	DSGD				3/7

TACT SWITCH SPECIFICATION(轻触开关说明书)

6.3 Environmental 环境

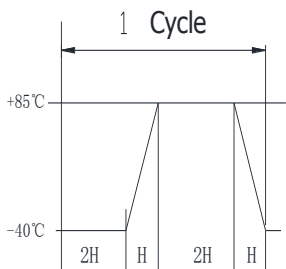
Item 项目	Test Condition 试验条件	Requirements 要求				
6.3.1. Resistance to Low Temperatures 耐低温	Following the test set forth below the sample shall be left in normal temperature and humidity conditions for one hour before measurements are made: 样品按下列条件进行耐低温试验, 测试前在正常温度和湿度条例上放置 1 小时 (1) Temperature: $-40\pm 2^{\circ}\text{C}$ 温度 (2) Time: 96 hours 时间 (3) Water drops shall be removed 擦除水珠	Contact resistance: 200m Ω Max. 接触电阻 Insulation resistance : 50 M Ω Min. 绝缘电阻 Item 6.1 Item 6.2.1 Item 6.2.2				
6.3.2. Heat Resistance 耐热	Following the test set forth below the sample shall be left in normal temperature and humidity conditions for one hour before measurements are made: 样品按下列条件进行耐热试验, 测试前在正常温度和湿度条件下放置 1 小时 (1) Temperature: $85\pm 2^{\circ}\text{C}$ 温度 (2) Time: 96 hours 时间	Contact resistance: 200m Ω Max. 接触电阻 Insulation resistance : 50 M Ω Min. 绝缘电阻 Item 6.1 Item 6.2.1 Item 6.2.2				
6.3.3. Moisture Resistance 耐潮湿	Following the test set forth below the sample shall be left in normal temperature and humidity conditions for one hour before measurements are made: 样品按下列条件进行耐潮湿试验, 测试前在正常温度和湿度条件下放置 1 小时 (1) Temperature: $60\pm 2^{\circ}\text{C}$ 温度 (2) Relative humidity: 90 to 95% 相对湿度 (3) Time: 96 hours 时间 (4) Water drops shall be removed 擦除水珠	Contact resistance: 200 m ohm max 接触电阻 Insulation resistance 50 M ohm min. 绝缘电阻 Item 6.1 Item 6.2.1 Item 6.2.2				
6.3.4. Temperature Cycling 温度循环	Following the test set forth below the sample shall be left in normal temperature and humidity conditions for one hour before measurements are made. 样品按下列条件进行温度循环试验, 测试前在正常温度和湿度条件下放置 1 小时 During this test, water drops shall be removed, 在试验期间, 擦除水珠。 Cycling: 20 cycles 周期: 20 次 	Contact resistance: 200 m ohm max 接触电阻 Insulation resistance 50 M ohm min. 绝缘电阻 Item 6.1 Item 6.2.1 Item 6.2.2				
	APPD CHKD DSGD	TD-601XB 160g				
ZONE	SYMB	DATE	APPD	CHKD	DSGD	4/7

TACT SWITCH SPECIFICATION(轻触开关说明书)

6.4 Endurance 耐久特性

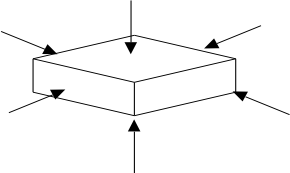
Item 项目	Test Condition 试验条件	Requirements 要求						
<p>6.4.1. Operating Life 动作寿命</p>	<p>Measurements shall be made following the test set forth below: 按下列条件进行寿命试验</p> <p>(1)DC 12V 50mA resistive load. DC 12V 50mA 阻性负载</p> <p>(2)Rate of operation:1 to 2 operations per second 动作频率:1-2 次/每秒</p> <p>(3)Depression: 240 gf 减压力</p> <p>(4)Cycles of operation: 100000 cycles 动作次数: 10 万次</p>	<p>Contact resistance: 200 mΩ Max. 接触电阻</p> <p>Insulation resistance : 50 MΩ Min. 绝缘电阻</p> <p>Actuating force: 动作力 + 30 %or- 30%of initial force. ±30%初始动作力</p> <p>Item 6.1.3 Item 6.2.2</p>						
<p>6.4.2. Vibration Resistance 耐振动</p>	<p>Measurements shall be made following the test set forth below: 按下列条件进行抗振动试验</p> <p>(1) Range of oscillation : 10 to 55 Hz 频率范围</p> <p>(2) Amplitude,pk-to -pk : 1.5mm 振幅: 峰-峰 1.5mm</p> <p>(3) Cycle of sweep : 10-55-10Hz in one minute, approx</p> <p>(4) Mode of sweep : Logarithmically sweep or</p> <p>(5) uniform sweep. 扫描周期: 10-55-10-Hz 约一分钟内</p> <p>(6) Direction of oscillation: 振动方向 Three mutually perpendicular directions, including the direction of stem travel, 3 个相互垂直方向, 包括推柄行程方向</p> <p>(7) Duration of testing 持续时间 2 hours each ,for a total of 6hours. 每方向 2 小时, 共 6 小时</p>	<p>Item 6.1 Item 6.2.1 Item 6.2.2</p>						
<p>6.4.3. Impact Shock Resistance 抗冲击</p>	<p>Measurements shall be made following the test set forth below: 按下列条件进行冲击试验</p> <p>(1) Acceleration : 80g 加速度</p> <p>(2) Cycles of test :3 cycles each in 6 directions,</p> <p>(3) for a total of 18cycles 试验次数: 每个方向 3 次, 6 个方向共 18 次</p> <div style="text-align: center;">  </div>	<p>Item 6.1 Item 6.2.1 Item 6.2.2</p>						
		<table border="1" style="margin: auto;"> <tr> <td style="width: 15%;">APPD</td> <td style="width: 15%;">CHKD</td> <td style="width: 15%;">DSGD</td> </tr> <tr> <td></td> <td></td> <td></td> </tr> </table>	APPD	CHKD	DSGD			
APPD	CHKD	DSGD						
		TD-601XB 160g						
		5/7						
ZONE	SYMB	DATE	APPD	CHKD	DSGD			

CTING SWITCH SPECIFICATION

7.1 Other precautions 其他注意事项

- (1) **Following the soldering process,do not try to clean the switch with a solvent or the like .**
进行焊接过程中，不可以用溶剂或类似品清洗开关
- (2) **Safeguard the switch assembly against flux penetration from its topside.**
防止助焊剂从开关的顶端渗入。
- (3) **Please have the products keep in close status and the storage time is 90 days guaranty after delivering the goods at most.**
交货后保证开关处于封密状态并库存时间不超过 90 天以上

						APPD	CHKD	DSGD	TD-601XB 160g
ZONE	SYMB	DATE	APPD	CHKD	DSGD				6/7

TACT SWITCH SPECIFICATION(轻触开关说明书)

7.2 SWITCH HANDLING PRECAUTION 使用开关时注意事项

1. In case an automatic flow soldering apparatus is use for soldering.

用自动焊接设备焊接时应参照如下条件

ITEM 项 目	SOLDERING CONDITIONS 焊接条件
PREHEAT TEMPERATURE 预热温度	180°C MAX (AMBIENT TEMPERATURE OF PRINTED CIRCUIT BOARD ON ITS SOLDERING SIDE) (电路板周围焊锡面的温 度)
PREHEAT TIME 预热时间	45 SEC MAX 45 秒 MAX
FLUX FOAMING 助焊剂浸泡	TO SUCH AN EXTENT THAT FLUX WILL BE KEPT FLUSH WITH THE PRINTED CIRCUIT BOARDS, TOP SURFACE ON WHICH COMPONENTS ARE MOUNTED. PREPARATORY FLUX MUST NOT BE APPLIED TO THAT SIDE OF PRINTED CIRCUIT BOARD ON WHICH COMPONENTS ARE MOUNTED AND TO THE AREA WHERE TERMINALS ARE LOCATED. 助焊剂应涂在电路板上组装开关的印刷面上半部位，应防止助焊剂过量到电路板。
SOLDERING TEMPERATURE 焊锡温度	260°C MAX 260°C MAX
DURATION OF SOLDER IMMERSION 焊接时间	5 SEC MAX 5 秒 MAX
ALLOWABLE FREQUENCY 允许重焊次数	2 TIMES MAX 2 次 MAX

2. Other precautions 其他注意事项

(1) FOLLOWING THE SOLDERING PROCESS, DO NOT TRY TO CLEAN THE SWITCH SOLVENT OR THE LIKE.

进行焊接工艺时不应使用不整洁的东西对开关进行清洁。

(2) SAFEGUARD THE SWITCH ASSEMBLY AGAINST FLUX PENETRATION FROM ITS TOP SIDE.

在组装开关时应防止助焊剂从开关的上部流入到开关内部。

						APPD	CHKD	DSGD	TD-601XB 160g
ZONE	SYMB	DATE	APPD	CHKD	DSGD				7/7