

RoHS compliant

FEATURES

- RoHS compliant
- Optimum for high density board mounting applications
- Compatible with most automatic pick & place machinery (J-hook and Gull wing types only)
- Compatible with reflow and wave soldering
- Protection against dust and washable after soldering
- Excellent reliability due to precious metal contact
- Resin materials are UL Recognized 94V-0 or 94V-1 equivalent

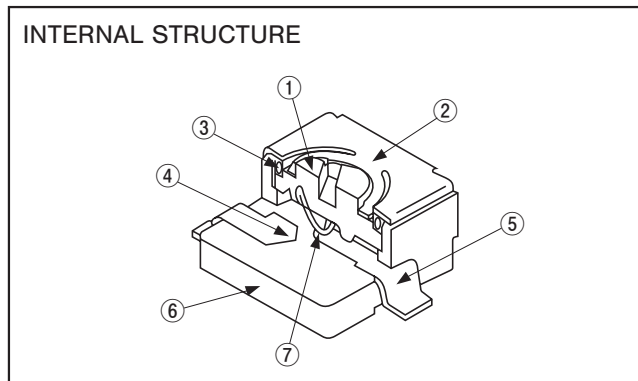

| Part name | Material |
|------------------|---------------------------|
| ① Rotor | Polyphenylenesulphide |
| ② Cover | Stainless steel (SUS 304) |
| ③ "O" ring | Silicone rubber |
| ④ Fixed contact | Copper alloy, Gold-plated |
| ⑤ Terminal pin | |
| ⑥ Housing | Epoxy |
| | ※ LCP (LC polymer) |
| ⑦ Slider contact | Multi metal alloy |

※ : 1 pole 4 contacts only

PART NUMBER DESIGNATION

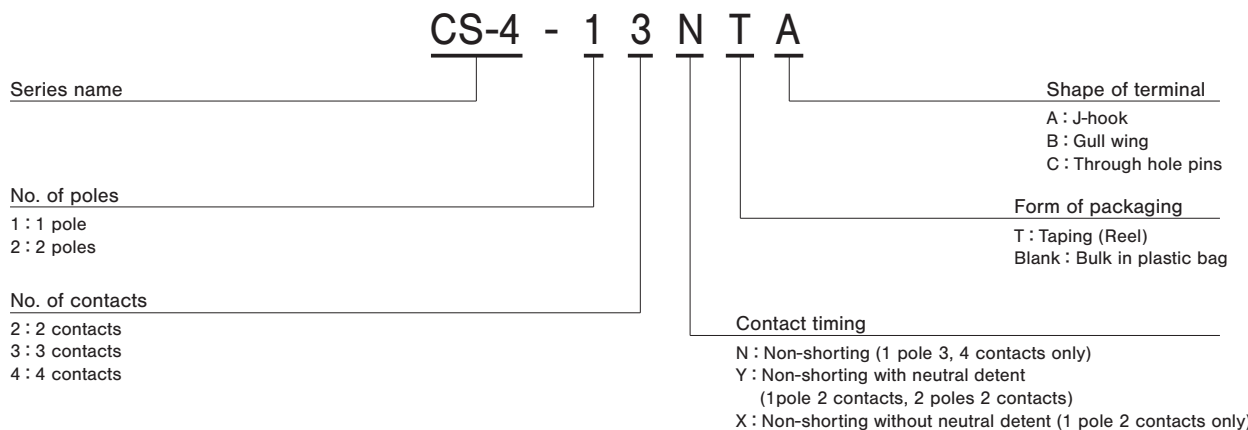

※ Please refer to the LIST OF PART NUMBERS when placing orders.

CS-4

ROTARY SELECTOR SWITCHES (SMD)

SCHEMATICS DIAGRAMS

● 1 pole 2 contacts

| Series | Switching specifications | Schematic |
|---|--------------------------|-----------|
| CS-4-12YA // YTA // YB // YTB // YC | | |
| CS-4-12XA // XTA // XB // XTB // XC | | |

● 1 pole 4 contacts

| Series | Switching specifications | Schematic |
|--|--------------------------|-----------|
| CS-4-14NA // NTA // NB // NTB | | |

● 1 pole 3 contacts

| Series | Switching specifications | Schematic |
|--|--------------------------|-----------|
| CS-4-13NA // NTA // NB // NTB | | |

● 2 poles 2 contacts

| Series | Switching specifications | Schematic |
|--|--------------------------|-----------|
| CS-4-22YA // YTA // YB // YTB | | |

LIST OF PART NUMBERS

| Circuit type | | Form of packaging | A J-hook | B Gull wing | C Through hole pin | Pieces in package |
|----------------------|------------------------|-------------------|-------------|----------------|-----------------------|-------------------|
| 1 pole 2 contacts | With neutral detent | Taping | CS-4-12YTA | CS-4-12YTB | CS-4-12YC | 500 pcs./reel |
| | | Plastic bag | CS-4-12YA | CS-4-12YB | | 50 pcs./pack |
| | Without neutral detent | Taping | CS-4-12XTA | CS-4-12XTB | CS-4-12XC | 500 pcs./reel |
| | | Plastic bag | CS-4-12XA | CS-4-12XB | | 50 pcs./pack |
| 1 pole 3 contacts | | Taping | CS-4-13NTA | CS-4-13NTB | | 500 pcs./reel |
| | | Plastic bag | CS-4-13NA | CS-4-13NB | | 50 pcs./pack |
| 1 pole 4 contacts | | Taping | CS-4-14NTA | CS-4-14NTB | | 500 pcs./reel |
| | | Plastic bag | CS-4-14NA | CS-4-14NB | | 50 pcs./pack |
| 2 poles 2 contacts | | Taping | CS-4-22YTA | CS-4-22YTB | | 500 pcs./reel |
| | | Plastic bag | CS-4-22YA | CS-4-22YB | | 50 pcs./pack |

☐: Not manufactured

※ Verify the above part numbers when placing orders.
Taping version can be supplied only in reel unit.

STANDARD SPECIFICATIONS

| | |
|-----------------------------|--|
| Circuit type | 1 pole 2 contacts 2 poles 2 contacts 1 pole 3 contacts 1 pole 4 contacts |
| Operating temperature range | - 25 ~ 70 °C |
| Storage temperature range | - 40 ~ 70 °C |
| Sealing | Washable by "O" ring ※ Please refer to page 150, 151 |
| Net weight | Approx. 0.08 g (CS-4-12, CS-4-13) Approx. 0.1 g (CS-4-14, CS-4-22) |

MECHANICAL CHARACTERISTICS

| | |
|-------------------|--|
| No. of positions | 2, 3, 4 |
| Adjustment torque | 10 mN·m {102 gf·cm} maximum |
| Stopper strength | 25 mN·m {255 gf·cm} minimum |
| Stepping angle | 45° 90° (CS-4-12X only) |
| Solderability | 245 ± 3 °C, 2 ~ 3 s |
| Soldering heat | Flow : 260 ± 3 °C as the temperature in a pot of molten solder, immersion from head of terminal to backside of board, 5 ~ 6 s, two times maximum Reflow : Peak temperature 255 °C (Please refer to the profile below.) Manual soldering : 350 ± 10 °C, 3 ~ 4 s |
| Shear (Adhesion) | 5 N {0.51 kgf}, 10 s |
| Substrate bending | Width 90 mm, bend 3 mm, 5 s, 1 time |
| Pull-off strength | 5 N {0.51 kgf}, 10 s |

{ } : Reference only

ELECTRICAL CHARACTERISTICS

| | |
|-----------------------|--------------------------|
| Contact rating | 0.5 VA |
| Maximum current | 100 mA |
| Minimum current | 1 μA |
| Maximum voltage | 16 V |
| Minimum voltage | 20 mV |
| Contact timing | Non-shorting |
| Contact resistance | 100 mΩ maximum |
| Insulation resistance | 100 MΩ (DC500 V) minimum |
| Dielectric strength | AC500 V, 60 s |

ENVIRONMENTAL CHARACTERISTICS

| | |
|---------------------------|---|
| Vibration | (Amplitude) 1.5 mm (or (Acceleration) 98 m/s ² , 10-500-10 Hz, 3 directions for 2 h each |
| Shock | 490 m/s ² , 11 ms 6 directions for 3 times each |
| Load life | 200 cycles minimum DC16 V, 30 mA |
| Humidity (Steady state) | 40 °C, Relative humidity 90 ~ 95 %, 48 h |
| High temperature exposure | 70 °C, 16 h |
| Low temperature exposure | - 40 °C, 16 h |
| Thermal shock | - 40 (0.5 h) ~ 70 °C (0.5 h), 5 cycles |

〈Reflow profile for soldering heat evaluation〉

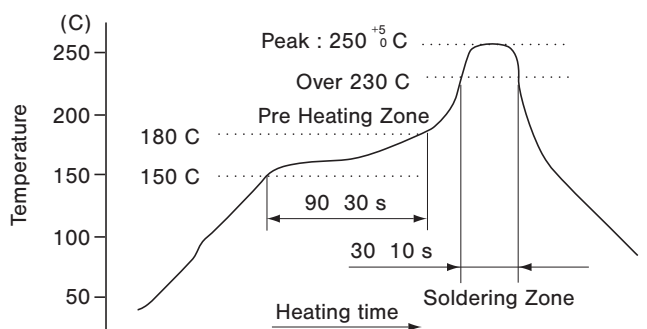

Reflow : two times maximum

CS-4

ROTARY SELECTOR SWITCHES (SMD)

OUTLINE DIMENSIONS

Unless otherwise specified, tolerance: ± 0.3 (Unit: mm)

CS-4-12YA

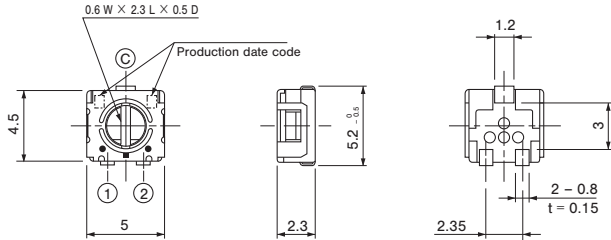

CS-4-12YB

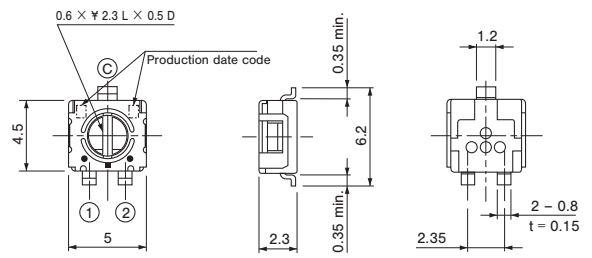

CS-4-12YC

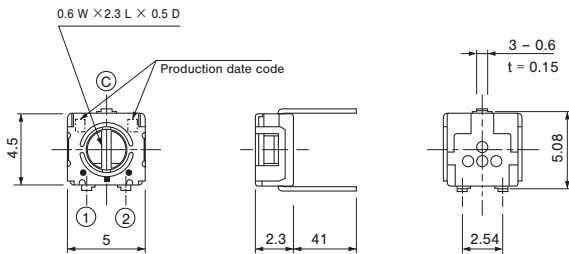

CS-4-12XA

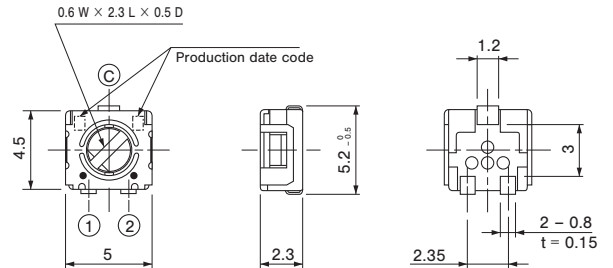

CS-4-12XB

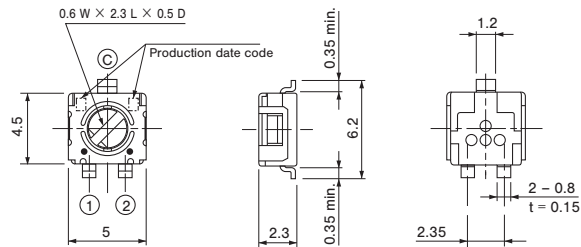

CS-4-12XC

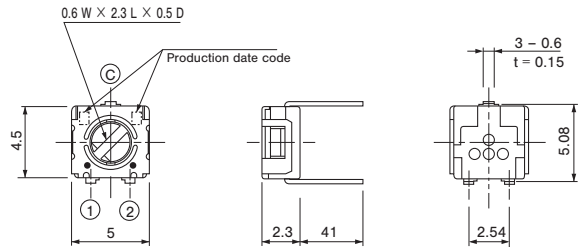

CS-4-13NA

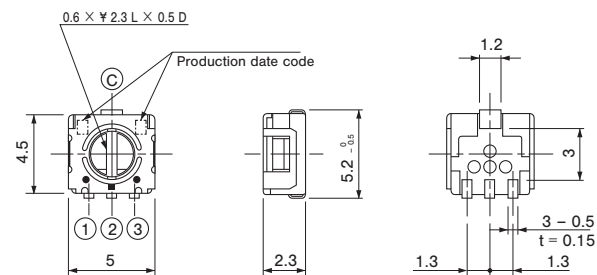

CS-4-13NB

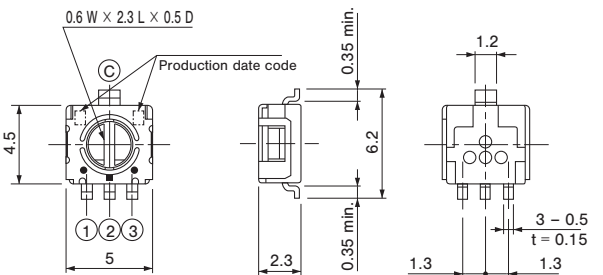

CS-4-14NA

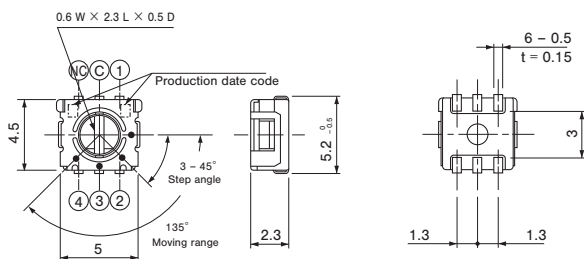

CS-4-14NB

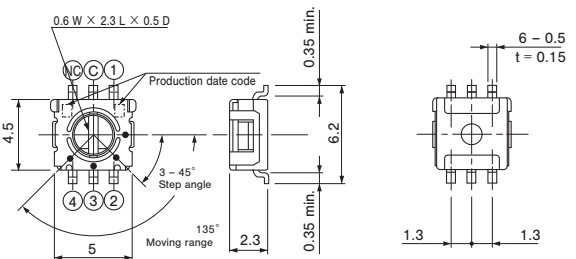

OUTLINE DIMENSIONS

CS-4-22YA

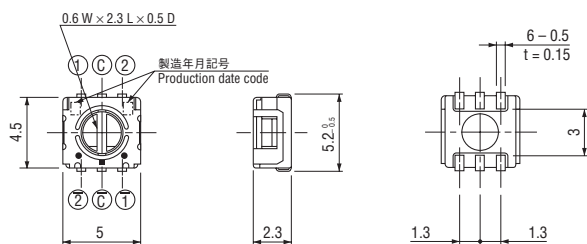

Unless otherwise specified, tolerance: ± 0.3 (Unit: mm)

CS-4-22YB

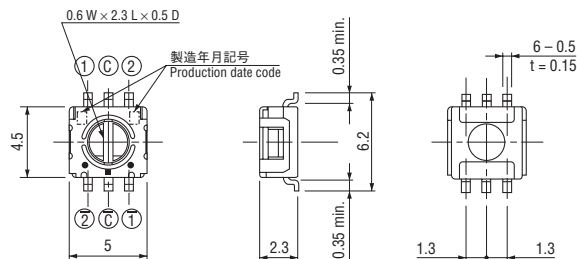

RECOMMENDED P.C.B. PAD OUTLINE DIMENSIONS

CS-4-12YA

CS-4-12XA

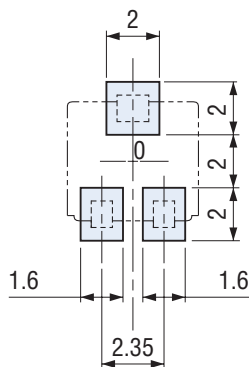

CS-4-12YB

CS-4-12XB

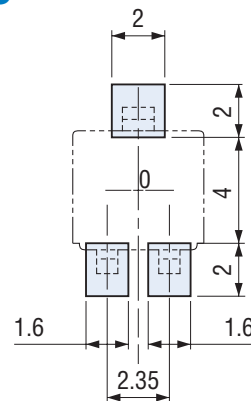

(Unit: mm)

CS-4-13NA

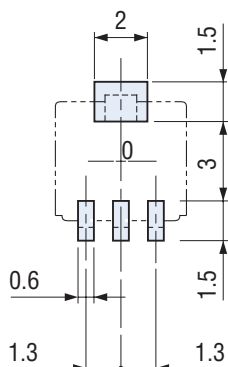

CS-4-13NB

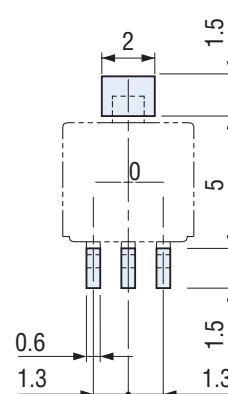

CS-4-14NA

CS-4-22YA

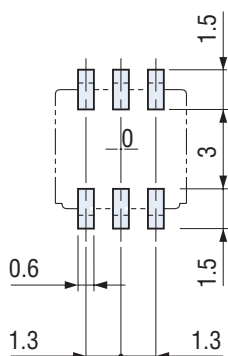

CS-4-14NB

CS-4-22YB

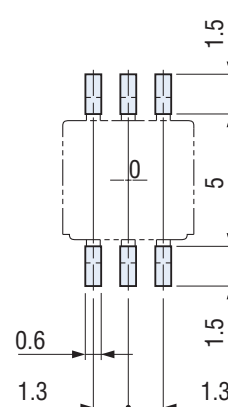

Note) The zero point is the center of mounting.

CS-4

ROTARY SELECTOR SWITCHES (SMD)

SOLDERING CONDITIONS

When dip-soldering CS-4-13NA, NB or CS-4-22YA, YB, solder bridges may occur between terminals depending upon soldering conditions.

In order to prevent such bridges, vertical flow direction is recommended as shown in the below figure.

For dip-soldering, preheating should be done after applying flux.

Handle carefully in case of parallel flow direction in which solder bridges occur more often because solder flow moves toward the vertical direction against the terminals.

In addition, other soldering conditions such as soldering temperature, preheating temperature, specific gravity of flux, and belt speed affect the occurrence of bridges.

Depending on flux to be applied, markings may, though at rare case, disappear or fade out at soldering. Please make sure before its use.

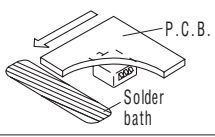
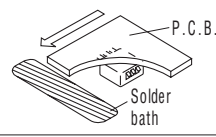
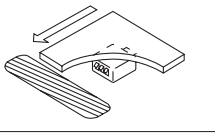
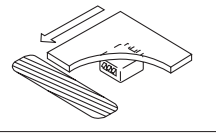
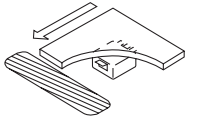
| Flow direction | CS-4-13NA, NB | CS-4-22YA, YB |
|----------------|---|--|
| Vertical |  |  |
| Parallel |  |  |
| |  | |

PACKAGING SPECIFICATIONS

<Taping packaging specifications>

- Taping version is packaged in 500 pcs. per reel.
Orders will be accepted for units of 500 pcs., i.e., 500, 1000, 1500 pcs., etc.
- Taping version is boxed with 4 reels (2000 pcs.).

Maximum number of consecutive missing pieces=2

Leader length and reel dimension are shown in the dia-grams below:

● Embossed tape dimensions

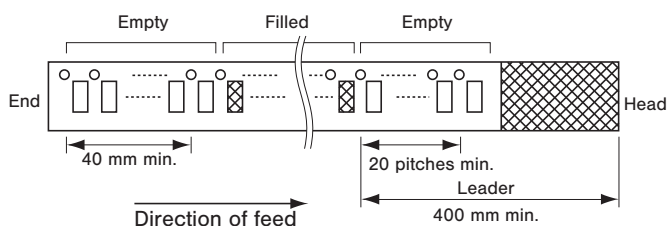

● Reel dimensions

(Unit: mm)

(Conforms to JIS C 0806-3)

(In accordance with EIAJ ET-7200A)

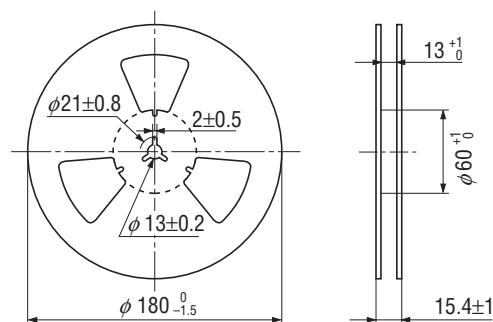

● CS-4-□□□ TA/CS-4-□□□ TB

(Conforms to JIS C 0806)

(Unit: mm)

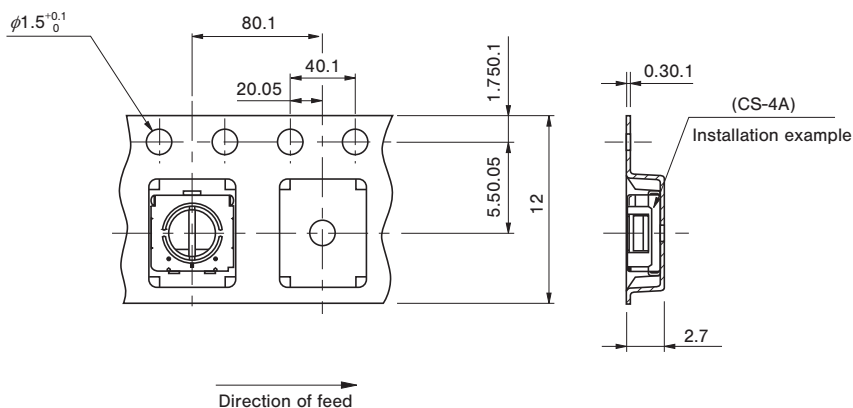

<Bulk pack specifications>

- The smallest unit of bulk pack in a plastic bag is 10 pcs. per pack. Orders will be accepted for unit of minimum 10 pcs., i.e., 10, 20, 30 pcs., etc.
- Boxing of bulk in a plastic bag is performed with 50 pcs. (standard 500 pcs.) per box.