



## LoRaWAN Gateway Module Datasheet

### Gateway module series

#### GL5211 LoRaWAN Gateway Module Datasheet

---

Version: V1.0.0

Data: 2021-10-15

## Document Information

Version	Time	Description	Remark
V1.0.0	2021-10-15	Preliminary version	Ming

## Copyright Notice

All contents in the files are protected by copyright law, and all copyrights are reserved by Shenzhen Naviecare Technology Co.,Ltd. Without written permission, all commercial use of the files from Naviecare are forbidden, such as copy, distribute, reproduce the files, etc., but non-commercial purpose, downloaded or printed by individual are welcome.

## Disclaimer

Shenzhen Naviecare Technology Co.,Ltd reserves the right to change, modify or improve the document and product described herein . Its contents are subject to change without notice. These instructions are intended for you use at your own risk .

## Table of Contents

1. Description.....	- 1 -
1.1 Overview.....	- 1 -
1.2 Product features.....	- 1 -
1.3 Function block diagram.....	- 2 -
2. Pin Definition.....	- 2 -
2.1 Pin assignment.....	- 2 -
2.2 Pin description.....	- 3 -
3. Specifications.....	- 4 -
3.1 General specifications.....	- 4 -
3.2 Electric specifications.....	- 5 -
3.3 Absolute maximum rating.....	- 5 -
3.4 Operating conditions.....	- 5 -
3.5 Operating conditions.....	- 6 -
3.6 RF Characteristics.....	- 6 -
3.7 Electrical Requirements.....	- 6 -
3.8 Operating Frequencies.....	- 7 -
4. Typical Hardware Connections.....	- 7 -
4.1 Physical dimensions.....	- 7 -
4.2 Reference Circuit.....	- 8 -
4.3 Interfaces.....	- 8 -
5. Reliability Test and Approves.....	- 9 -
6. Package.....	- 9 -
7. Contact US.....	- 9 -

## 1. Description

### 1.1 Overview

GL5211 is a LoRa gateway module with industrial standard mini PCI express form factor based on SX1302 chipset. This mPCIe module can be used in any embedded platform offering a free mPCIe slot with SPI connectivity and capable of providing enough power for the module, enables low-power wide area communication capabilities to your new gateway design or existing industrial routers/computer.

GL5211 is a complete and cost efficient LoRa gateway solution offering up to ten(10) programmable parallel demodulation paths, an 8 x 8 channel LoRa packet detectors, 8 x SF5-SF12 LoRa demodulators and 8 x SF5-SF10 LoRa demodulators. It is capable of detecting uninterrupted combination of packets at 8 different spreading factors and 10 channels with continuous demodulation of up to 16 packets. It targets Internet-of-Things (IoT) applications, covering up to 500 nodes per square kilometer in an environment with moderate interference.

GL5211 LoRa gateway module are available in six product variants:

NO.	Model	Description	Remark
1	GL5211-C	470~510 MHz, is mainly designed for China.	
2	GL5211-CX	470~510 MHz, with LBT function, is mainly designed for China.	
3	GL5211-E	863~870 MHz, is mainly designed for operation in Europe and other countries.	
4	GL5211-EX	863~870 MHz, with LBT function, is mainly designed for operation in Europe and other countries.	
5	GL5211-U	902~928 MHz, is mainly designed for operation in America south-east Asia.	
6	GL5211-UX	902~928 MHz, with LBT function, is mainly designed for operation in America south-east Asia.	

Table 1.1 Product model list

### 1.2 Product features

- ✓ **Multichannel:** ten(10) programmable parallel demodulation paths, an 8 x 8 channel LoRa packet detectors, 8 x SF5-SF12 LoRa demodulators and 8 x SF5-SF10 LoRa demodulators, one 125 /250 / 500 kHz high-speed LoRa demodulator and one (G)FSK demodulator.
- ✓ **SPI Interface:** The SPI interface gives access to the configuration register of SX1302 via a synchronous full-duplex protocol.
- ✓ Compact min-PCI express form factor TYP. 50.95\*30\*10.5mm (W\*L\*H)
- ✓ Environmentally friendly RoHS compliant
- ✓ Voltage of mini PCI-e is 3.3V, compatible with 3G/LTE mPCIe card
- ✓ Tx power up to 27dBm, Rx sensitivity down to -139dBm@SF12, BW125kHz

### 1.3 Function block diagram

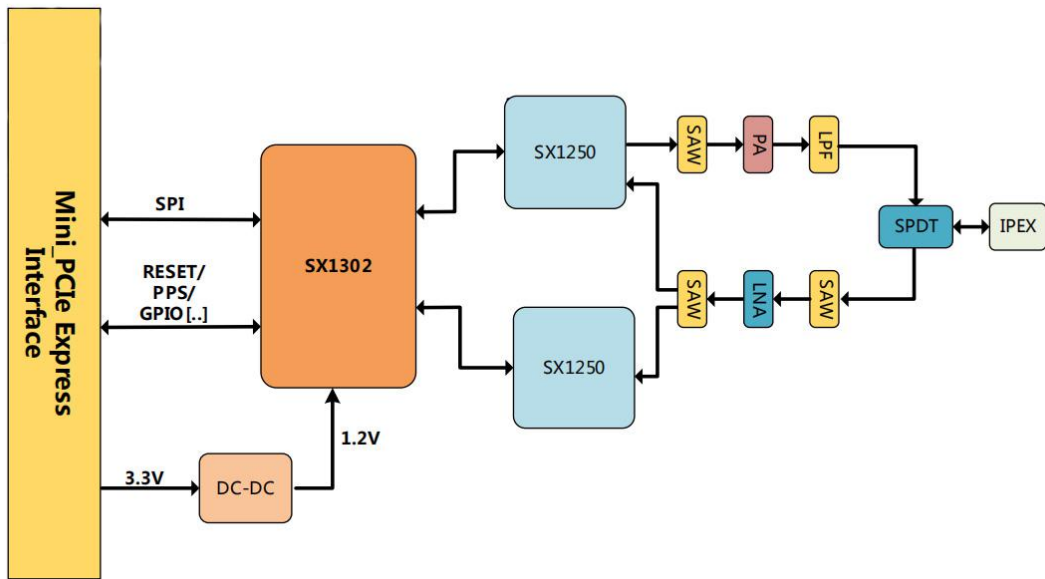

Figure 1.3 Functional block diagram

## 2. Pin Definition

### 2.1 Pin assignment

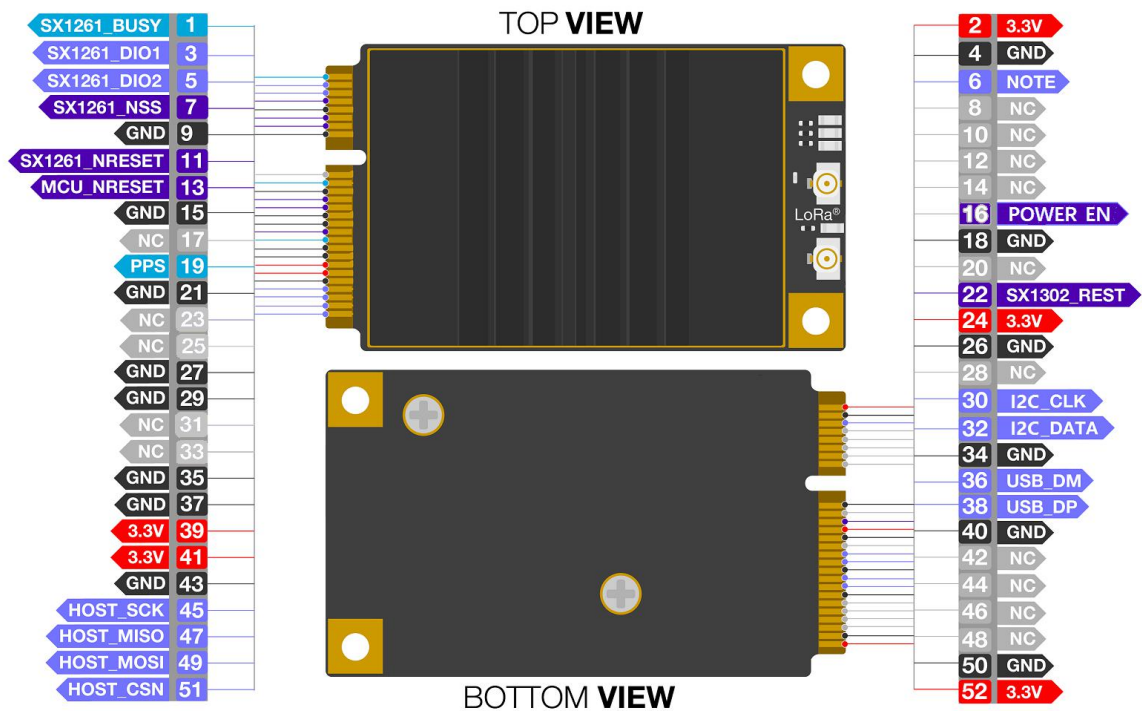

Figure 2.1 Pin definition diagram

## 2.2 Pin description

No.	Mini PCIe Pin Rev 2.0	Type	Description
1	NC	N/A	No Connection.Reserved for SX1261_BUSY
2	+3.3V	Power input	3.3V DC supply.
3	NC	N/A	No connection.Reserved for SX1261_DIO1
4	GND	GND	Ground
5	NC	N/A	No connection.Reserved for SX1261_DIO2
6	1.5V	I/O	Connect to SX1302's GPIO[6]
7	NC	N/A	No connection.Reserved for SX1261_NSS
8	NC	N/A	No connection
9	GND	GND	Ground
10	NC	N/A	No connection
11	NC	N/A	No connection.Reserved for SX1261_NRESET
12	NC	N/A	No connection
13	MCU_NRESET	DI	No connection.Reserved for future applications
14	NC	N/A	No connection
15	GND	GND	Ground
16	NC	N/A	No connection.Reserved for POWER_EN
17	NC	N/A	No connection
18	GND	GND	Ground
19	1PPS	DO	GPS time pulse input, Leave open if
20	NC	N/A	No connection
21	GND	GND	Ground
22	SX1302-Reset	DI	Active high $\geq$ 100ns for SX1302 Reset input
23	NC	N/A	No connection
24	+3.3V	PI	3.3V DC supply
25	NC	N/A	No connection
26	GND	GND	Ground
27	GND	GND	Ground
28	NC	N/A	No connection
29	GND	GND	Ground
30	I2C_SCL	I/O	Connect the SCL of the internal temperature detection sensor. If you are not using it, please keep it open.
31	NC	N/A	No connection
32	I2C_SDA	I/O	Connect the SDA of the internal temperature detection sensor. If you are not using it, please keep it open.

33	NC	N/A	No connection
34	GND	GND	Ground
35	GND	GND	Ground
36	NC	N/A	No connection.Reserved for USB_DM
37	GND	GND	Ground
38	NC	N/A	No connection.Reserved for USB_DP
39	+3.3V	PI	3.3DC supply
40	GND	GND	Ground
41	+3.3V	PI	3.3V DC supply
42	NC	N/A	No connection
43	GND	GND	Ground
44	NC	N/A	No connection
45	HOST_SCK	I/O	Host SPI CLK
46	NC	N/A	No Connection
47	HOST_MISO	I/O	Host SPI MISO
48	NC	N/A	Not connected
49	HOST_MOSI	I/O	Host SPI MISI
50	GND	N/A	Ground
51	HOST_CSN	I/O	Host SPI CS
52	+3.3V	PI	3.3V DC supply

**Table 2.2 Pin definition**

## 3. Specifications

### 3.1 General specifications

Parameters	Description
Modulation type	ISM Band LoRa <sup>®</sup>
LoRa chipset	SX1302
Multi-channel	Eight (8) uplink, one (1) down link
Package	Mini PCI express
Host interface	SPI
Frequency	863~870MHZ, 902~928MHZ(Opt.),CN470MHz
Receiving sensitivity	-139dBm
Tx power	+27dBm
Supply voltage	+3.3V
Power consumption	Tx (Max)<415mA,Rx <40mA, standby 7.5mA

Operating temperature	-40~+85°C (industrial grade)
Operating humidity	10%~90%, no-condensing
Dimensions	TYP. 50.95*30*10.5mm (W*L*H)
ESD (Human Body Model)	JEDEC JS-001 Standard ±1kV, Class 2

Table3.1 General specification

### 3.2 Electric specifications

**ESD Notice:** GL5211 is a high-performance radio frequency device. It satisfies:

- ✓ Class 2 of the JEDEC standard JESD22-A114 (Human Body Model) on all pins.
- ✓ Class III of the JEDEC standard JESD22-C101 (Charged Device Model) on all pins

It should thus be handled with all the necessary ESD precautions to avoid any permanent damage.



The limiting values given are in accordance with the Absolute Maximum Rating System. Stress above one or more of the limiting values may cause permanent damage to the device. These are stress ratings only, and operation of the device at these or at any other conditions above those given in the Characteristics sections of the specification is not implied. Exposure to these limits for extended periods may affect device reliability.

### 3.3 Absolute maximum rating

Symbol	Description	Condition	Min	Max.	Unit
3.3Vaux	Module supply voltage	Input DC voltage at 3.3Vaux pins	-0.3	3.6	V
RESET	MPCI reset input	Input DC voltage at RESET input pin	-0.3	3.6	V
SPI	SPI interface	Input DC voltage at SPI interface pin	-0.3	3.6	V
GPS_PPS	GPS 1 pps input	Input DC voltage at GPS_PPS input pin	-0.3	3.6	V
I2C	Temperature detection	Input DC voltage at I2C input pin	-0.3	3.6	V
Rho_ANT	Antenna ruggedness	Output RF load mismatch ruggedness at ANT1		10:1	VSWR
Tstg	Storage Temperature		-40	85	°C

Table3.3 absolute maximum rating



Stressing the device beyond the “Absolute Maximum Ratings” may cause permanent damage. The product is not protected against over-voltage or reversed voltages. If necessary, voltage spikes exceeding the power supply voltage specification, given in table above, must be limited to values within the specified boundaries by using appropriate protection diodes.

### 3.4 Operating conditions



All specifications are at an ambient temperature of 25 ° C. Extreme operating temperatures can significantly impact specification values. Applications operating near the temperature limits should be tested to ensure the specification.



Parameter	Min.	Typ	Max.	Unit	Remarks
Normal operating temperature	-40	+25	+85	°C	Normal operating temperature range

**Table3.4 operating temperature range**



Operating beyond the specified operating conditions can affect device reliability.

### 3.5 Operating conditions

#### 3.5.1 Power Supply Range

The table below lists the power supply range. Input voltage at 3.3V<sub>aux</sub> must be above the normal operating range minimum limit to switch-on the module.

Symbol	Parameter	Min.	Typical	Max.	Unit
3.3V	Module supply operating input voltage	3.00	3.30	3.60	V

**Table3.5.1 Operating power supply range**



Operating beyond the specified operating conditions can affect device reliability.

#### 3.5.2 Power Consumption

Mode	Condition	Min.	Typical	Max.
Active-Mode(TX)	The power of TX channel is 27dBm and 3.3V supply.	500mA	520mA	550mA
Active-Mode(RX)	TX disabled and RX enabled.	70mA	85mA	105mA

**Table3.5.2 Working current**

### 3.6 RF Characteristics

The following table gives typically sensitivity level of the GL5211 card.

Signal Bandwidth/[KHz]	Spreading Factor	Sensitivity/[dBm]
125	SF12	-139
125	SF10	-134
125	SF7	-125
125	SF5	-121
GFSK_50	50 kbps, GFSK modulation	-111
250	SF9	-124

**Table3.6 RF characteristics**

### 3.7 Electrical Requirements

Stressing the device above one or more of the ratings listed in the Absolute Maximum Rating section may cause permanent damage. These are stress ratings only. Operating the module at these or at any conditions other than

those specified in the Operating Conditions sections of the specification should be avoided. Exposure to Absolute Maximum Rating conditions for extended periods may affect device reliability.

The operating condition range define those limit within which the functionality of the device is guaranteed. Where application information is given, it is advisory only and does not form part of the specification.

### 3.8 Operating Frequencies

The board supports the following LoRaWAN frequency channels, allowing easy configuration while building the firmware from the source code.

Region	Frequency (MHz)
Europe	EU868
North America	US915
Asia	AS923
Australia	AU915
Korea	KR920
Indian	IN865
China	CN470

Table3.8 operating frequencies

## 4. Typical Hardware Connections

### 4.1 Physical dimensions

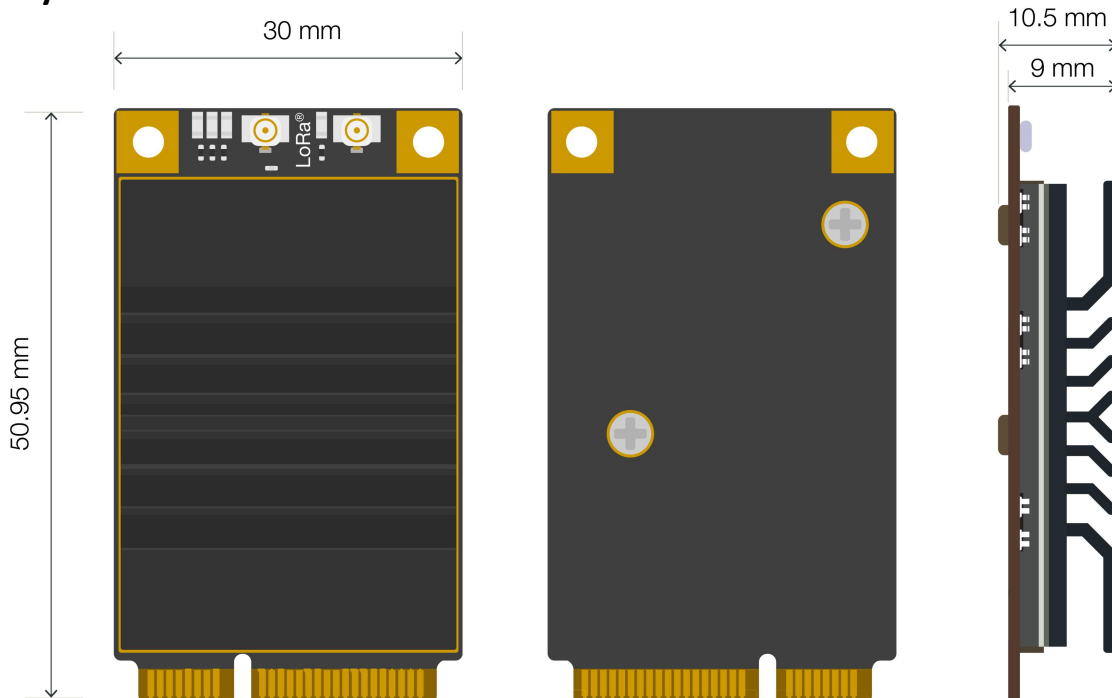

Figure 4.1 dimensions

Item	Length	Width	Thickness	Unit	Remark
Dimensions	50.95	30	10.5	mm	

Table 4.1 dimensions

### 4.2 Reference Circuit

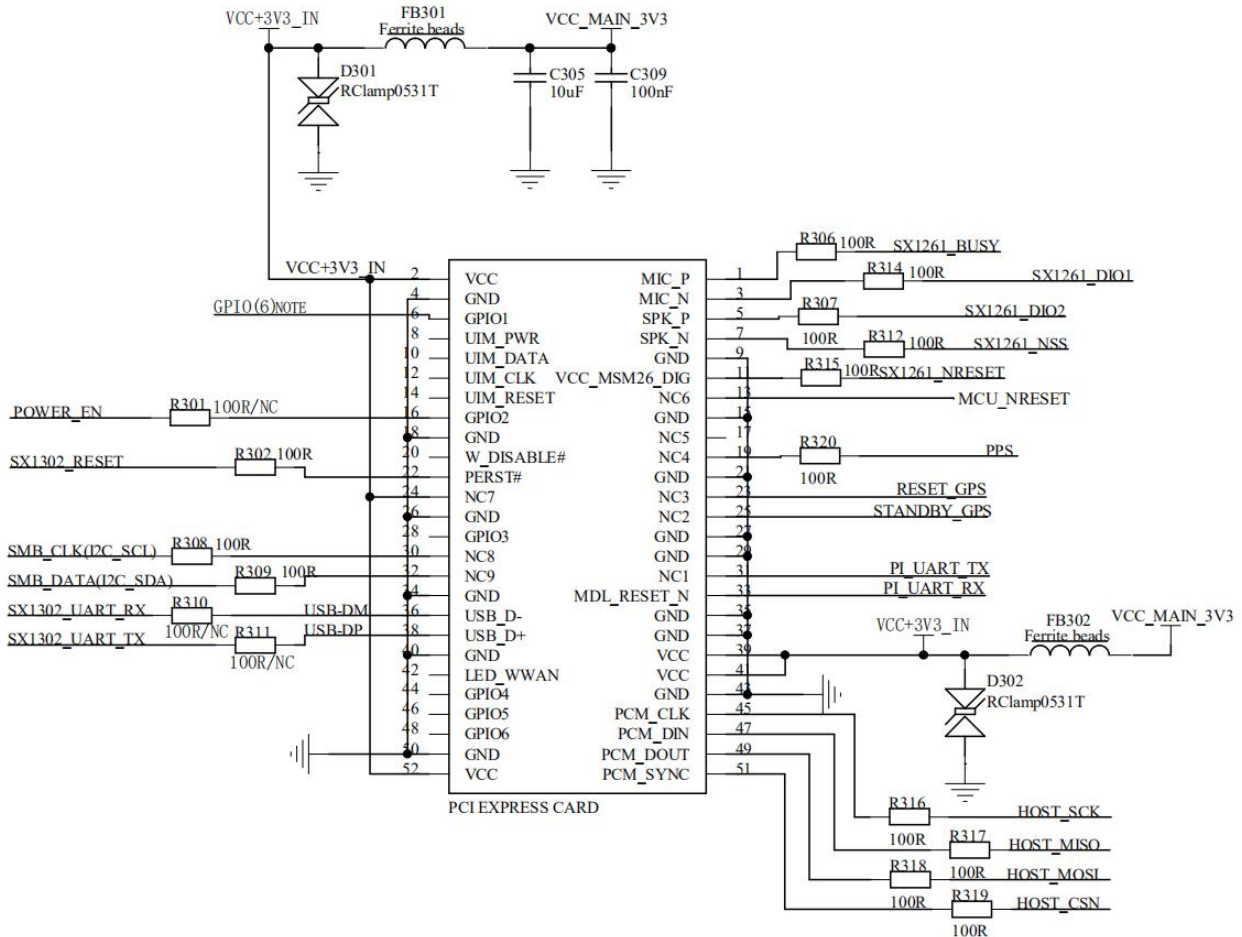

Figure 4.2 Reference Circuit of GL5211

### 4.3 Interfaces

Reference circuit design shows the typical hardware connections for the module. Interfacing to the module requires connecting to the signals provided on the GL5211 mPCIe connector as listed in pin description. Specific interface connections are discussed in this chapter.

#### 4.3.1 SPI Interface

SPI interface is provided on the Host\_SCK, Host\_MISO, Host\_MOSI, Host\_CSN pins of the system connector. The SPI interface gives access to the configuration register of SX1302 via a synchronous full-duplex protocol. Only the slave side is implemented.

#### 4.3.2 Power pins

GL5211 series modules has multiple power and ground pins available on the mPCIe connector. It is recommended that all power and ground pins be used when connecting to the module.

**4.3.3 RF connection**

The modules have two RF interfaces over standard UFL connector (Hirose U. FL-R- SMT) with the characteristic impedance of 50Ω. Port (J1) is the LoRa antenna interface and Port (J2) is the GPS antenna interface.

**4.3.4 RESET pin**

GL5211 series modules card includes the RESET active-high input signal to reset the radio operations as specified by the SX1302 Specification.

**4.3.5 GPS\_PPS**

GL5211 card includes the GPS\_PPS input for received packets time-stamped.

**4.3.6 I2C Interface**

GL5211 integrates STTS series temperature sensor, which is connected by I2C interface. The PIN on the golden finger provides I2C connection, allowing I2C to directly connect to the sensor, and obtain the temperature information detected by the current module sensor

**5. Reliability Test and Approves**

Tests for product family qualifications are according to ISO 16750 "Road vehicles – Environmental conditions and testing for electrical and electronic equipment”, and appropriate standards.



Products marked with this lead-free symbol on the product label comply with the "Directive 2002/95/EC and Directive 2011/65/EU of the European Parliament and the Council on the Restriction of Use of certain Hazardous Substances in Electrical and Electronic Equipment" (RoHS). All Naviecare GL5211 modules are RoHS compliant.

**6. Package**

Module	Package			Article number
	Form	QTY	Size	
GL5211	Trays	As required	As required	Undetermined

Table6.1 package

**7. Contact US**

Shenzhen Naviecare Technology Co.,Ltd

Web: <http://www.naviecare.com/>

Tel:+86-755-2645-9429 13510632596

Fax: +86-755-2947-6513

Office address : Room 302,3F, No. 16, Lane 1,Liuxian No.2 Road,Bao'an District.

518100 Shenzhen, China