

DESCRIPTION

The MT7853BD is a high-PF, non-isolate LED Driver IC. The floating-ground, high-side BUCK topology makes full wave detection possible. High precision output current is achieved. MT7853BD works in Quasi-Resonant Mode (QRM), which improves both of efficiency and EMI performance.

The system integrates the ultra-high voltage power supply circuit, the start-up resistor and power supply diode are not needed. MT7853BD also integrates compensation circuit, which eliminates COMP pin and COMP capacitor. MT7853BD can meet low THD requirements through internal THD compensation circuit.

Various protections such as over voltage protection (OVP), over current protection (OCP) and over temperature compensation, etc. are embedded to improve reliability. The MT7853BD integrates 600V MOSFET, which further simplifies external circuit.

FEATURES

- Single-stage active power factor correction (PFC > 0.90)
- Ultra-high voltage power supply without start-up resistor and power supply diode
- Built-in compensation circuit, no COMP capacitor is needed
- Integrate THD compensation circuit, THD < 15%
- High subharmonic-Distortion-Suppression
- High accurate LED current ($\pm 3\%$)
- Good Line and Load Regulation ($\pm 2\%$)
- Quasi-Resonant mode (QRM) operation
- Various protection schemes
- Available in DIP7 packages

APPLICATIONS

- E14/E27/PAR30/PAR38/GU10 LED lamp
- T8/T10 LED tube
- Other LED lighting applications

Typical Application Circuit

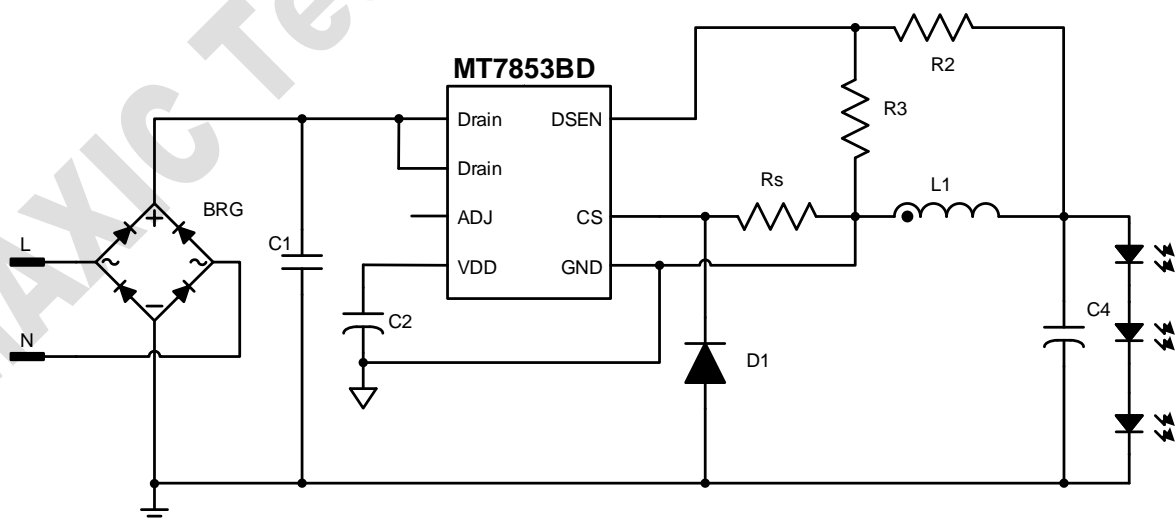

ABSOLUTE MAXIMUM RATINGS

VDD Pin Voltage	-0.3V to 30V
DRAIN Pin Voltage	-0.3V to 600V
CS/DSEN/ADJ Pins Voltage	-0.3V to 6V
Lead Temperature (soldering, 10 sec.)	260°C
P _{DMAX} (maximum power consumption)	0.8W
Storage Temperature	-55°C to 150°C
Junction Temperature (T _j)	150°C

Recommended operating conditions

Supply voltage	7.2V to 12V
Operating Temperature (Environment)	-40°C to 125°C
Input Power (Environment temperature ≤90°C)	≤24W @176VAC~265VAC ≤18W @85VAC~265VAC

Thermal resistance^①

Junction to ambient (R _{θJA})	70°C/W
Junction to Case (R _{θJC})	47°C/W

Note:

- ① R_{θJA}, R_{θJC} are measured in the natural convection at TA = 25°C on a low effective single layer thermal conductivity test board of JEDEC 51-3 thermal measurement standard. Test condition: Device mounted on 2" X 2" FR-4 substrate PCB, 2oz copper, with minimum recommended pad on top layer and thermal vias to bottom layer ground plane.

ORDERING INFORMATION

Part Number	Package	Packing Method	Chip Mark
MT7853BD	DIP7	Tube 50 Pcs/Tube	MT7853BD YYWWXXX XXXX

PIN CONFIGURATIONS

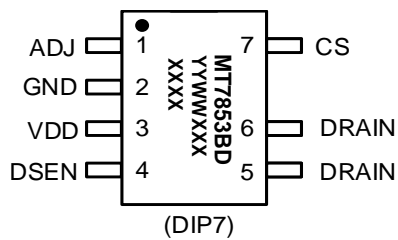

Chip Mark

MT7853BD: Part Number
Y: Year Code
W: Week Code
X: Manufacture code

PIN DESCRIPTION

Name	Pin No.	Description
ADJ	1	T_{ON_MAX} adjusting pin. When this pin is left floating, the T_{ON_MAX} is maximum.
GND	2	Ground pin.
VDD	3	Power Supply pin.
DSEN	4	Feedback pin for inductor zero current crossing detection.
DRAIN	5,6	Drain of internal MOSFET.
CS	7	Source of internal MOSFET, and Current Sense pin.

ELECTRICAL CHARACTERISTICS

(Test conditions: $V_{DD}=12V$, $T_A=25^{\circ}C$ unless otherwise stated.)

Symbol	Parameter	Conditions	Min	Typ	Max	Unit
Start-up (VDD Pin)						
V_{STP}	Start-up Voltage	VDD Ramp-up from 0V	10.8	12	13.2	V
UVLO	Under Voltage Lockout	VDD Ramp-down from ($V_{STP}+1V$)	7	8	9	V
I_{STP}	Start-up Current	VDD=12V	15	30	50	μA
Power Supply Current						
I_Q	Quiescent Current		0.33	0.4	0.5	mA
Control Loop (DSEN Pin)						
V_{REF-FB}	Voltage Reference for Feedback Loop	Close the Feedback Loop	194	200	206	mV
OVP	Over Voltage Protection of DSEN Pin		3.0	3.2	3.5	V
LEB1	Leading Edge Blank for DSEN Pin		1.56	2	2.44	us
MinT	Minimum Switching Period		7.8	10	12.2	us
T_{OFF_MAX}	Maximum OFF time		195	250	305	μs
T_{ON_MAX}	Maximum ON time	Refer to "TON_MAX Adjusting" Section	21	27.5	35	μs
Current Sense Pin (CS Pin)						
OCP	Threshold of Over Current Protection at CS Pin		1.3	1.4	1.5	V
LEB2	Leading Edge Blank for CS Pin		240	300	360	ns
Thermal Protection						
T_{Trig}	Temperature compensation trigger point		142.5	150	157.5	$^{\circ}C$
Internal MOSFET (DRAIN Pin)						
R_{on}	Internal MOSFET turn-on resistance	$V_{GS}=10V/I_{DS}=1.0A$		3.5		Ω
BV_{DSS}	Breakdown voltage	$V_{GS}=0V/I_{DS}=250\mu A$	600	650		V

BLOCK DIAGRAM

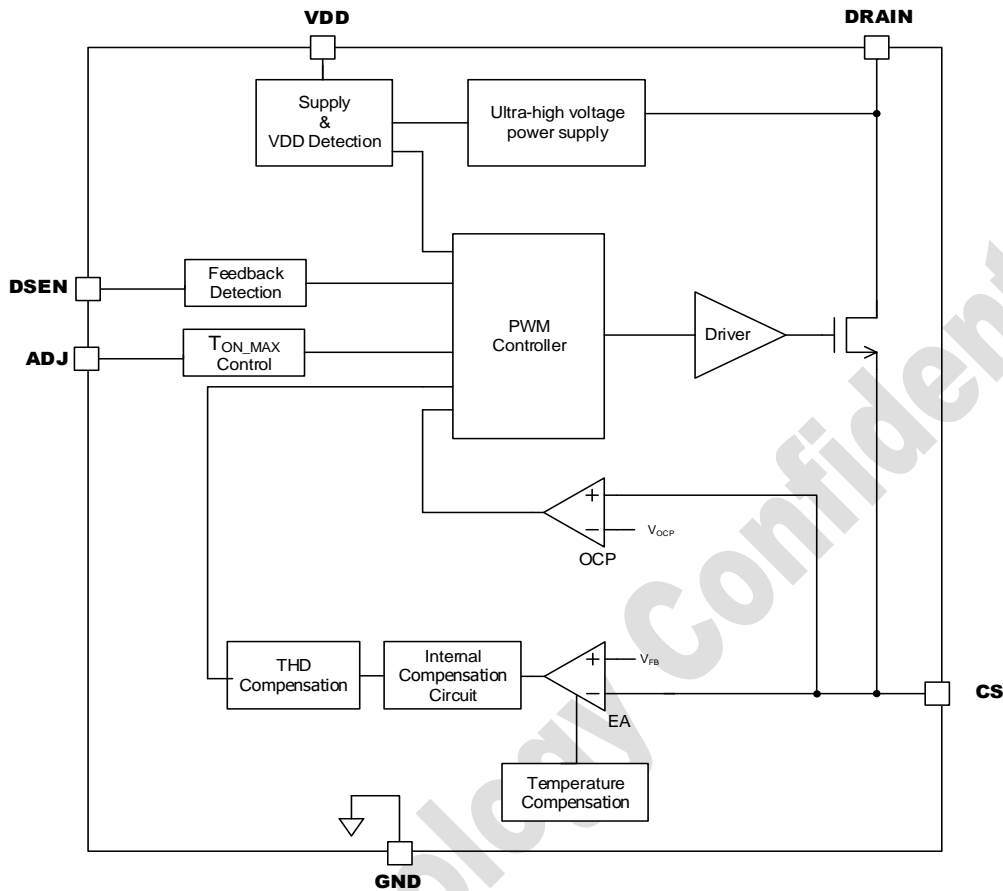

APPLICATION INFORMATION

The MT7853BD integrates compensation circuit, which eliminates COMP pin and COMP capacitor. It completely avoids the disturbance caused by board-level leakage or interference on the COMP pin. The system starts up fast.

MT7853BD integrates an adaptive THD compensation circuit. The compensation value will be automatically adjusted according to the system operating mode, without any external compensation circuit, the system can achieve THD less than 15% @220Vac. And the system can effectively reduce the odd harmonic components to meet the IEC61000-3-2 standard. It's insensitive to inductance and the inductance can be selected arbitrarily in a wide range.

Averaged Current Control

The MT7853BD accurately regulates LED current through sensing the inductor current signal. The LED current can be easily set by:

$$I_{LED} = \frac{V_{FB}}{R_S}$$

Where V_{FB} (=200mV) is the internal reference voltage and R_S is an external current sensing resistor (Refer to the typical application circuit in page1).

Start Up and High Voltage Power Supply

MT7853BD integrates ultra-high voltage power supply circuit, the VDD directly gets the power

from the DRAIN pin (Pin5&6) without start-up resistor and power supply diode. During start-up, the capacitor at VDD is charged through the internal ultra-high voltage power supply circuit. The internal control logic starts to work when VDD reaches 12V.

As the VDD goes below 8V, the system is considered to be UVLO, the MOSFET is turned off.

When the system works in normal operation, the MT7853BD controls the internal ultra-high voltage power supply circuit to charge the VDD capacitor. The circuit stops to provide power once the VDD voltage exceeds 12V, and resumes provide power as the VDD voltage lower than 11.5V. So the VDD voltage keeps in about 12V as the system works in normal operation.

Auxiliary Sensing

The voltage waveform of the inductor is sensed during PWM OFF period for switching logic control, over-voltage protection (OVP), short-circuit protection (SCP), etc.

The DSEN pin senses the inductor voltage through a resistor divider. The sampling strobe window is 2us LEB (Leading Edge Blanking) time right after the MOSFET is turned off for better noise immunity, as shown in Fig. 2.

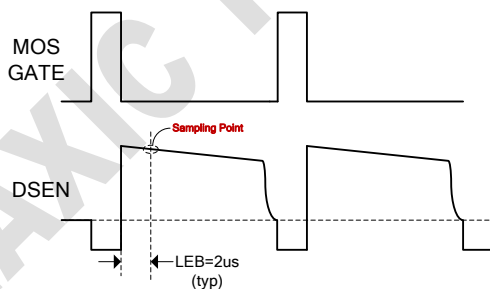

Fig.2 Auxiliary Signal Sensing

Hiccup Mode

Once detected any fault conditions, such as, over-voltage (OV), short-circuit (SC) conditions, the MT7853BD goes into hiccup mode. PWM

signal is turned off. The chip quiescent current drops lower (about 100uA). After about 400ms, the internal ultra-high voltage power supply circuit stops providing power to VDD. The VDD capacitor is therefore discharged. Then VDD continues to drop below UVLO threshold. A start-up sequence is initiated.

If the fault conditions are removed, the LED driver goes back to normal.

The hiccup mode keeps the system at low power dissipation state during fault conditions, enhancing system reliability.

Over-voltage Protection

The MT7853BD integrates Over Voltage Protection function. If the DSEN voltage exceeds 3.2V three times accumulatively during PWM OFF period (Refer to "Auxiliary Sensing"), the MT7853BD gets in Hiccup mode to protect the system and lower the power consumption. The threshold of Over Voltage Protection for LED can be set as following (refer to the application circuit in page 1):

$$V_{OUT_OV} = 3.2 \times \left(1 + \frac{R2}{R3}\right)$$

Short-circuit Protection

The MaxOFF is triggered for a continuous time of 12 to 16ms. The MT7853BD gets into hiccup mode.

Over-current Protection

The MT7853BD immediately turns off the power MOSFET once the voltage at CS pin exceeds 1.4V. This cycle by cycle current limitation scheme prevents the relevant components, such as power MOSFET, inductor, etc. from damage.

Temperature Compensation

When the Junction Temperature reaches 150°C(±7.5°C), the compensation circuit starts to

reduce output current along with the temperature increasing. As the junction temperature drops below 150°C(±7.5°C), the output current back to normal level. This thermal fold back scheme prevents the system goes into thermal runaway.

T_{ON_MAX} Adjusting

The T_{ON_MAX} can be set through adjusting the ratio of R_{ADJ} and R_{DSEN}, as shown in Fig. 3.

R _{ADJ} /R _{DSEN} ratios	T _{ON_MAX} (μs)
0	4.4
1.5	4.9
2.5	5.5
3.5	6.4
4.5	7.3
5.5	8.8
6.5	11
∞	27.5

Refer to the typical application circuit in page1, the R_{DSEN} is the total equivalent resistance on DSEN pin, so it is the parallel value of R2 and R3, since R2 is much greater than R3, R_{DSEN} is approximately equal to R3.

Limited by T_{ON_MAX}, the output current begins to decrease when the main voltage is lower than a certain threshold. The lower the T_{ON_MAX}, the main voltage threshold will be higher.

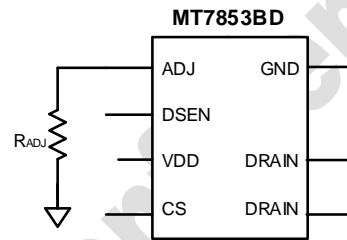
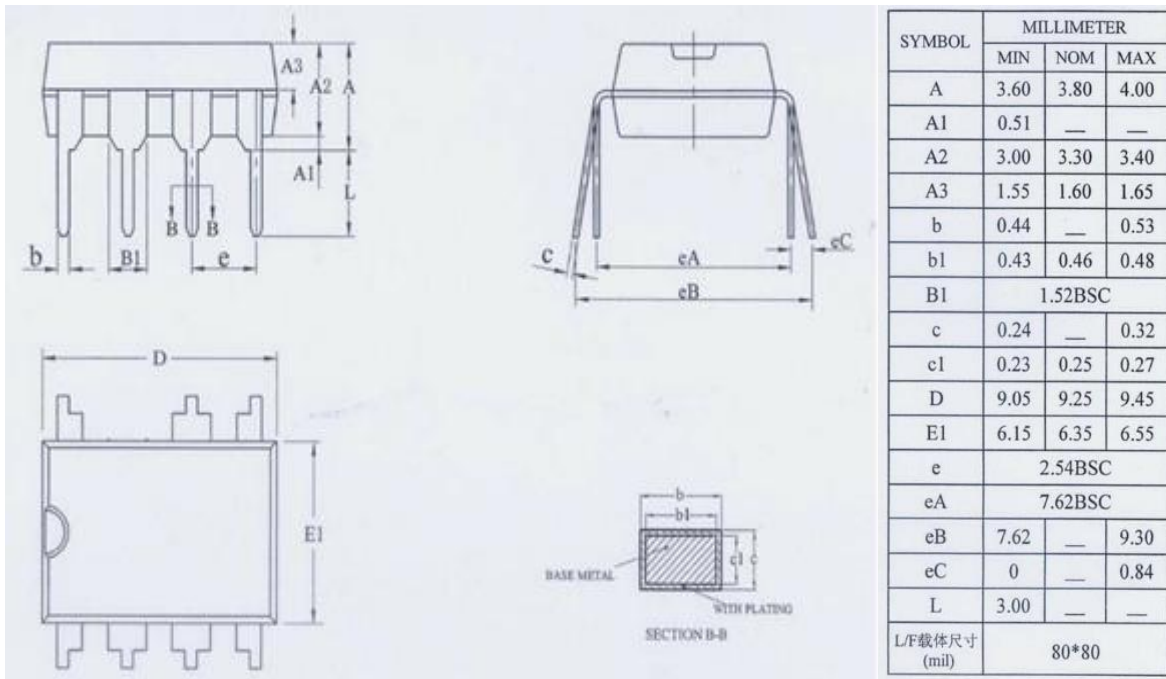

Fig.3 T_{ON_MAX} Adjusting

PACKAGE INFORMATION



Important Notice

- Maxic Technology Corporation (Maxic) reserves the right to make correction, modifications, enhancements, improvements and other changes to its products and services at any time and to discontinue any product or service without notice. Customers should obtain the latest relevant information before placing orders and should verify that such information is current and complete. All products are sold subject to Maxic's terms and conditions of sale supplied at the time of order acknowledgement.
- Reproduction, copying, transferring, reprinting this paper without Maxic's written permission is prohibited.
- Maxic assumes no liability for applications assistance or the design of customers' products. Maxic warrants the performance of its products to the specifications applicable at the time of sale. Customers are responsible for their products and applications using Maxic components. To minimize the risks associated with customers' products and applications, customers should provide adequate design and operating safeguards.