

3 Appearance and dimensions

Unit [mm]

Negative polarity marking

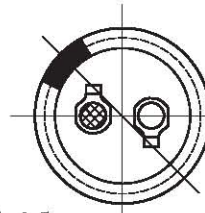
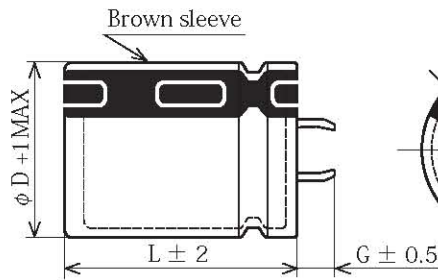
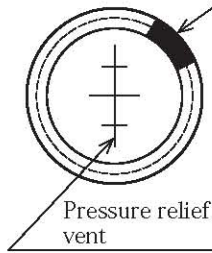

D	L	G
35	50	3.5

or

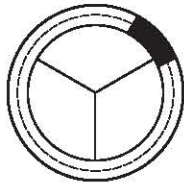

Terminal dimensions

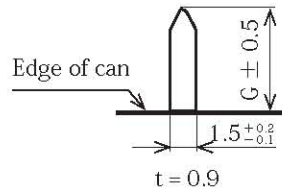

PC board pin-out

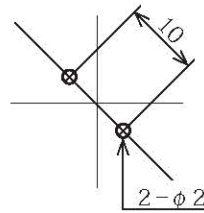

4 Construction

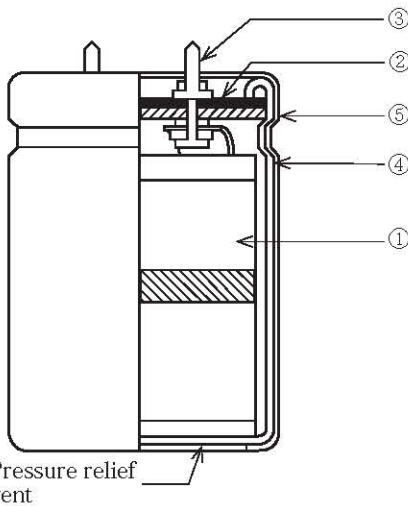

No.	Composition	Materials
①	Anode foil	Aluminum
	Cathode foil	Aluminum
	Separator	Paper
	Fixing tape	P.P tape
	Electrolyte	
②	Seal material	Rubber - laminated Bakelite
③	Terminals	SPCC (tin coated copper clad steel)
④	Case	Aluminum
⑤	Sleeve	PET

※ Ozone depleting substance is not used.

※ RoHS Directive(2002/95/EC)

Substances banned in the RoHS directive are not used in these products.

5 Rating and characteristics

No.	Item	Specification	Conditions
1	Category temperature range	- 25 to + 105°C	
2	Rated voltage	500 V _{dc}	
3	Surge voltage	550 V _{dc}	
4	Rated capacitance	390 μF	at + 20°C ,120Hz
5	Capacitance tolerance	- 20 to + 20%	at + 20°C ,120Hz
6	Dissipation factor (tan δ)	0.25 Max.	at + 20°C ,120Hz
7	Leakage current	1320 μA Max.	at + 20°C after 5minutes, rated voltage
8	Rated ripple current	1.51 Arms	at + 105°C ,120Hz

Rated ripple current multipliers

Frequency multipliers

Frequency [Hz]	50	120	300	1k	10k	50k
Rated voltage [V _{dc}]						
500	0.77	1.00	1.16	1.30	1.41	1.43

When the frequency of ripple current is different from the specified condition, do not exceed the value obtained by multiplying the rated ripple current by the multiplier above.

6 Marking

The following items shall be marked on each capacitor.(White marking)

- | | |
|------------------------------|--------------------------------------|
| ① Rated voltage | ⑤ Manufacturer's identification mark |
| ② Rated capacitance | ⑥ Series name |
| ③ Upper category temperature | ⑦ Capacitance tolerance |
| ④ Negative polarity marking | ⑧ Lot No. |

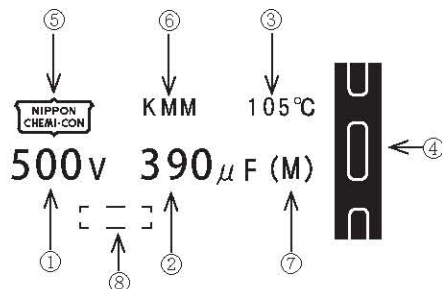

Finish method

- 1.The rivet head of the negative terminal shall be carved in a grid pattern ④.
- 2.The sleeve shall be placed on the capacitor body so that its negative polarity marking can fit to the negative terminal.

7 Performance

Unless otherwise specified, the capacitors shall be measured at a temperature of + 15 to + 35°C , a humidity of 45 to 75% RH and an atmospheric pressure of 86 to 106kPa. However, if any doubt arises on the judgment, the measurement conditions shall be + 20 ± 2°C , 60 to 70% RH and 86 to 106kpa.

7.1 Leakage current (L.C.)

- [Conditions] Rated voltage shall be applied to capacitors in series with a resistor of $1000 \pm 10 \Omega$. Then, leakage current shall be measured at the end of a specified period after the capacitors reached the rated voltage across the terminals.
- [Criteria] As specified in section 5.

7.2 Capacitance (Cap.)

- [Conditions] Measuring frequency : 120Hz ± 20%
- Measuring voltage : 0.5Vrms max. + 1.5 to + 2.0V_{dc}
- Measuring circuit : Series equivalent circuit (○—|—||—○)
- [Criteria] As specified in section 5.

7.3 Dissipation factor (tan δ)

- [Conditions] Measuring frequency : 120Hz ± 20%
- Measuring voltage : 0.5Vrms max. + 1.5 to + 2.0V_{dc}
- Measuring circuit : Series equivalent circuit (○—|—||—○)
- [Criteria] As specified in section 5.

7.4 Terminal strength

(1)Pull strength

- [Conditions] The capacitor body shall be clamped. A force shall be gradually applied to the terminal in the horizontal axis of the terminal, and retained for 10 ± 1 seconds after reaching the pull force specified below.

Pull force [N]
20

- [Criteria] The terminal shall neither loosen nor break away.

(2)Bending strength

- [Conditions] A pull force shall be gradually applied to the terminal in the mechanically weakest direction of the terminal, and retained for 30 ± 5 seconds after reaching the pull force specified below. If the terminal is bent , it shall be raised up to its original position, and then the pull force shall be applied in the opposite direction in the same manner.

Bending force [N]
25

- [Criteria] The terminal shall neither loosen nor break away.

7.5 Soldering heat

[Conditions]	Type of solder	: Sn-3Ag-0.5Cu
	Flux	: Ethanol solution (25 wt.% rosin)
	Solder temperature/immersion time	: + 260 ± 5°C for 10 ± 1 seconds or + 350 ± 10°C for 3.5 ± 0.5 seconds.
	Depth of immersion	: Up to 1.5 to 2.0mm from the root of the terminal covered with a thermal shield plate.
	Speed of immersion	: 25 ± 2.5mm/sec.
[Criteria]	Appearance	: No significant damage.
	Leakage current	: Shall not exceed the initial specified value.
	Capacitance change	: Shall be within ± 10% of the initial measured value.
	Dissipation factor (tan δ)	: Shall not exceed the initial specified value.

7.6 Solderability

[Conditions]	Type of solder	: Sn-3Ag-0.5Cu
	Flux	: Ethanol solution (25 wt.% rosin)
	Solder temperature	: + 245 to + 250°C
	Solder immersion time	: 2 ± 0.5 seconds
	Speed of immersion	: 25 ± 2.5mm/sec.
[Criteria]	Solder shall cover at least 3/4 of the immersed surface of the terminal.	

7.7 Vibration

[Conditions]	Vibration frequency range	: 10 to 55Hz
	Peak to peak amplitude	: 1.5mm
	Sweep rate	: 10 to 55 to 10Hz, about 1 minute.
	Direction and time	: 2 hours in each of 3 mutually perpendicular directions. (total of 6 hours)
	※ The capacitors shall be fixed to test equipment by means of any clamp.	
[Criteria]	Capacitance(during test)	: The reading shall be stable.
	Appearance	: No significant damage.
	Capacitance change	: Shall be within ± 5% of the initial measured value.

7.8 Damp heat

[Conditions]	Temperature	: + 40 ± 2°C
	Relative humidity	: 90 to 95% RH
	Time	: 240 ± 8 hours
[Criteria]	Appearance	: No significant damage.
	Leakage current	: Shall not exceed the initial specified value.
	Capacitance change	: Shall be within ± 15% of the initial measured value.
	Dissipation factor (tan δ)	: Shall not exceed the initial specified value.

7.9 Endurance

[Conditions]	After the capacitors are subjected to a DC voltage with the specified rated ripple current within the rated voltage for 3000 ± 7% hours at + 105 ± 3°C , the following specifications shall be satisfied at + 20°C . The sum of a DC voltage and a peak AC voltage must not exceed the full rated voltage.	
[Criteria]	Leakage current	: Shall not exceed the initial specified value.
	Capacitance change	: Shall be within ± 20% of the initial measured value.
	Dissipation factor (tan δ)	: Shall not exceed 200% of the initial specified value.

7.10 Surge voltage test

[Conditions]	Temperature	: + 15 to + 35°C
	Series protective resistor	: 1000 ± 10 Ω
	Voltage	: As specified in section 5.
	Applying condition	: 30 ± 5 seconds every 6 ± 0.5 minutes.
	Number of cycle	: 1000 cycles.
[Criteria]	Leakage current	: Shall not exceed the initial specified value.
	Capacitance change	: Shall be within ± 15% of the initial measured value.
	Dissipation factor (tan δ)	: Shall not exceed the initial specified value.

7.11 Pressure relief vent

[Conditions] Apply a reverse voltage with the DC current shown the table below.

Diameter of capacitor [mm]	DC current [A]
22.4mm and smaller	1
Over 22.4mm	10

[Criteria] When the vent operates, the capacitor shall not flame although emission of gas and blowout of a part of the inside element is allowable. If the vent does not operate with the voltage applied for 30 minutes, it is considered to be passed the test.

7.12 High Temperature Storage

[Conditions] After the capacitors are subjected to $+ 105 \pm 3^\circ\text{C}$ for 1000^{+48} hours without voltage applied, the following specifications shall be satisfied at $+ 20^\circ\text{C}$. Before the measurements, the capacitor shall be preconditioned by applying voltage according to Item 4.1 of JIS C 5101-4.

[Criteria] Leakage current : Shall not exceed the initial specified value.
 Capacitance change : Shall be within $\pm 15\%$ of the initial measured value.
 Dissipation factor (tan δ) : Shall not exceed 150% of the initial specified value.

7.13 High and low temperature characteristics

[Conditions] Step 1 : Measure capacitance and impedance.

Step 2 : Measure impedance.

Step 3 : Measure capacitance.

Step	Temperature [$^\circ\text{C}$]
1	$+ 20 \pm 2$
2	$- 25 \pm 3$
3	$+ 105 \pm 3$

[Criteria] Step 2 Impedance ratio : Shall not exceed the values shown in the table below.

Step 3 Capacitance change : Shall be within $\pm 25\%$ of the initial measured value at step 1.

Impedance ratio	[120Hz]
Rated voltage [V_{dc}]	500
$Z(-25^\circ\text{C})/Z(+20^\circ\text{C})$	15

8 Others

8.1 Export Trade Control Ordinance (When our products are exported from Japan)

(1) Export Trade Control Ordinance (Section 1 through 15 of Appendix Table 1).

Export regulation of the capacitors for pulse use (750V or higher) and the capacitors for high voltage (5,000V or higher) is carried out according to (item 41-4) in Section 2 of Appendix Table 1 (Section 49 in Chapter 1 of METI's Ordinance) and (item 7) in Section 7 of Appendix Table 1 (Section 6 in Chapter 6 of METI's Ordinance). However, the aluminum electrolytic capacitors, which are described in this specification, don't fulfill the regulated level. Therefore, the aluminum electrolytic capacitors are not applicable to Export Trade Control Ordinance.

(2) Export Trade Control Ordinance (Section 16 of Appendix Table 1)

The aluminum electrolytic capacitors, which are described in this specification, are applicable to goods under Export Regulations (Category 85 of Appendix Table in Customs Tariff Law) based on Section 16 of Appendix Table 1 in Export Trade Control Ordinance.

If the exporter got information that their export goods can be used in the development of weapon, the exporter must apply for exporting permission to Ministry of Economy, Trade and Industry (METI), and get METI's approval.

Regardless of the above, if the exporter is notified by METI that his/her export goods can be potentially used in the development of weapon, the exporter must seek permission from METI to export, and get METI's approval. When Nippon Chemi-Con receives such notice from METI, we will inform your company of that.

8.2 Cleaning PC board

These products are not solvent-proof type.

8.3 Manufacturing plant

CHEMI-CON FUKUSHIMA CORPORATION(JAPAN)

CHEMI-CON (MALASIA) SDN.BHD.(MALASIA)

UNITED CHEMI-CON,INC.(U.S.A)

8.4 For aluminum electrolytic capacitors, please refer to PRECAUTIONS AND GUIDELINES.

PRECAUTIONS AND GUIDELINES(Aluminum Electrolytic Capacitors)

Designing Device Circuits

[1] Select the capacitors to suit installation and operating conditions, and use the capacitors to meet the performance limits prescribed in this catalog or the product specifications.

[2] Polarity

Aluminum Electrolytic Capacitors are polarized. Apply neither reverse voltage nor AC voltage to polarized capacitors. Using reversed polarity causes a short circuit or venting. Before use, refer to the catalog, product specifications or capacitor body to identify the polarity marking. (The shape of rubber seal does not represent the directional rule for polarity.) Use a bi-polar type of non-solid aluminum electrolytic capacitor for a circuit where the polarity is occasionally reversed. However, note that even a bi-polar aluminum electrolytic capacitor must not be used for AC voltage applications.

[3] Operating voltage

Do not apply a DC voltage which exceeds the full rated voltage. The peak voltage of a superimposed AC voltage (ripple voltage) on the DC voltage must not exceed the full rated voltage. A surge voltage value, which exceeds the full rated voltage, is prescribed in the catalogs, but it is a restricted condition, for especially short periods of time.

[4] Ripple current

Do not apply overcurrent which exceeds the full rated ripple current. The superimposition of a large ripple current increases the rate of heating within the capacitor. When excessive ripple current is imposed the internal temperature increases which may occur failure mode as follows.

- Shorten lifetime
- Open vent
- Short circuit

The rated ripple current has been specified at a certain ripple frequency. The rated ripple current at several frequencies must be calculated by multiplying the rated ripple current at the original frequency using the frequency multipliers for each product series. For more details, refer to the paragraph on Aluminum Electrolytic Capacitor Life.

[5] Category temperature

Do not apply over temperature which exceeds the maximum category temperature.

The use of a capacitor outside the maximum rated category temperature will considerably shorten the life or cause the capacitor to vent. The relation between the lifetime of aluminum electrolytic capacitors and ambient temperature follows Arrhenius' rule that the lifetime is approximately halved with each 10°C rise in ambient temperature.

[6] Life expectancy

Select the capacitors to meet the service life of a device.

[7] Charge and discharge

Do not use capacitors in circuits where heavy charge and discharge cycles are frequently repeated. Frequent and sharp heavy discharging cycles will result in decreasing capacitance and damage to the capacitors due to generated heat. Specified capacitors can be designed to meet the requirements of charging-discharging cycles, frequency, operating temperature, etc.

[8] Failure mode of capacitors

Non-solid aluminum electrolytic capacitors, in general, have a lifetime which ends in an open circuit, but depending on conditions of usage or products type, failure mode of capacitors will be venting. Please contact a representative of Nippon Chemi-Con.

[9] Insulating

Electrically isolate the following parts of a capacitor from the negative terminal, the positive terminal and the circuit traces.

- The outer can case of a non-solid aluminum capacitor.
- The dummy terminal of a non-solid aluminum capacitor, which is designed for mounting stability.

[10] The outer sleeve

The outer sleeve of a capacitor is not assured as an insulator (Except for screw type).

[11] Condition

Do not use/expose capacitors to the following conditions.

- a) Oil, water, salty water storage in damp locations.
- b) Direct sunlight
- c) Toxic gases such as hydrogen sulfide, sulfurous acid, nitrous acid, chlorine or its compounds, and ammonium.
- d) Ozone, ultraviolet rays or radiation
- e) Severe vibration or mechanical shock conditions beyond the limits prescribed in the catalogs or the product specification.

[12] Mounting

- a) The paper separators and the electrolytic-conductive electrolytes in a non-solid aluminum electrolytic capacitor are flammable. Leaking electrolyte on a printed circuit board can gradually erode the copper traces, possibly causing smoke or burning by short-circuiting the copper traces. Verify the following points when designing a PC board.
 - Provide the appropriate hole spacing on the PC board to match the terminal spacing of the capacitor.

- Make the following open space over the vent so that the vent can operate correctly.

<u>Case diameter</u>	<u>Clearance</u>
φ 6.3 to φ 16mm	2mm minimum
φ 18 to φ 35mm	3mm minimum
φ 40mm and up	5mm minimum

- Do not place any wires or copper traces over the vent of the capacitor.
 - Installing a capacitor with the vent facing the PC board needs an appropriate ventilation hole in PC board.
 - Do not pass any copper traces beneath the seal side of a capacitor. The trace must pass 1 or 2mm to the side of the capacitor.
 - Avoid placing any heat-generating objects adjacent to a capacitor or even on the reverse side of the PC board.
 - Do not pass any via holes underneath a capacitor on double sided PC board.
 - In designing double-sided PC boards, do not locate any copper trace under the seal side of a capacitor.
- b) Do not mount the terminal side of a screw mount capacitor downwards. If a screw terminal capacitor is mounted on its side, make sure the positive terminal and vent are higher than the negative terminal. Do not tighten the screws of the terminals and the mounting clamps over the specified torque prescribed in the catalog or the production specification.
- c) For a surface mount capacitor, design the copper pads of the PC board in accordance with the catalog or the product specifications.

[13] Others

- a) Using capacitor for applications which always consider safety. Consult with our factory before use in applications which can affect human life. (space equipment, aerial equipment, nuclear equipment, medical equipment, vehicle control equipment, etc) Please note that the product, which is designed only for specific usage cannot be used in other usages. (ex. Photo flash type, etc.)
- b) The electrical characteristics of capacitors vary in respect to temperature, frequency and service life. Design the device circuits by taking these changes into account.
- c) Capacitors mounted in parallel need the current to flow equally through the individual capacitors.
- d) Capacitors mounted in series require resistors in parallel with the individual capacitors to balance the voltage.

Installing Capacitors

[1] Installing

- a) Used capacitors are not reusable, except in the case that the capacitors are detached from a device for periodic inspection to measure their electrical characteristics.
- b) If the capacitors have self charged, discharge in the capacitors through a resistor of approximately 1k Ω before use.
- c) If capacitors are stored at a temperature of 35°C or more and more than 75% RH, the leakage current may increase. In this case, they can be reformed by applying the rated voltage through a resistor of approximately 1k Ω.
- d) Verify the rated capacitance and voltages of the capacitors when installing.
- e) Verify the polarity of the capacitors.
- f) Do not use the capacitors if they have been dropped on the floor.
- g) Do not deform the cases of capacitors.
- h) Verify that the lead spacing of the capacitor fits the hole spacing in the PC board before installing the capacitors. Some standard pre-formed leads are available.
- i) For radial or snap-in terminals, insert the terminals into PC board and press the capacitor downward until the bottom of the capacitor body reaches PC board surface.
- j) Do not apply any mechanical force in excess of the limits prescribed in the catalogs or the product specifications of the capacitors. Also, note the capacitors may be damaged by mechanical shocks caused by the vacuum/insertion head, component checker or centering operation of an automatic mounting or insertion machine.

[2] Soldering and Solderability

- a) When soldering with a soldering iron
- Soldering conditions (temperature and time) should be within the limits prescribed in the catalogs or the product specifications.
 - If the terminal spacing of a capacitor does not fit the terminal hole spacing of the PC board, reform the terminals in a manner to minimize a mechanical stress into the body of the capacitor.
 - Remove the capacitors from the PC board, after the solder is completely melted, reworking by using a soldering iron minimizes the mechanical stress to the capacitors.
 - Do not touch the capacitor body with the hot tip of the soldering iron.
- b) Flow soldering
- Do not dip the body of a capacitor into the solder bath only dip the terminals in. The soldering must be done on the reverse side of PC board.
 - Soldering conditions (preheat, solder temperature and dipping time) should be within the limits prescribed in the catalogs or the product specifications.
 - Do not apply flux to any part of capacitors other than their terminals.
 - Make sure the capacitors do not come into contact with any other components while soldering.

- c) Reflow soldering
 - Soldering conditions (preheat, solder temperature and soldering time) should be within the limits prescribed in the catalogs or the product specifications.
 - When setting the temperature infrared heaters, consider that the infrared absorption causes material to be discolored and change in appearance.
 - Do not solder capacitors more than two times using reflow. If you need to do three times, be sure to consult with us.
 - Make sure capacitors do not come into contact with copper traces.
 - Vapor phase soldering (VPS) is not used.
- d) Do not re-use surface mount capacitors which have already been soldered. In addition, when installing a new capacitor onto the assembly board to rework, remove old residual flux from the surface of the PC board, and then use a soldering iron within the prescribed conditions.
- e) Confirm before running into soldering that the capacitors are SMD for reflow soldering.

[3] Handling after soldering

Do not apply any mechanical stress to the capacitor after soldering onto the PC board.

- a) Do not lean or twist the body of the capacitor after soldering the capacitors onto the PC board.
- b) Do not use the capacitors for lifting or carrying the assembly board.
- c) Do not hit or poke the capacitor after soldering to PC board. When stacking the assembly board, be careful that other components do not touch the aluminum electrolytic capacitors.
- d) Do not drop the assembly board.

[4] Cleaning PC boards

- a) Do not wash capacitors by using the following cleaning agents.
 - Halogenated solvents; cause capacitors to fail due to corrosion.
 - Alkali system solvents; corrode (dissolve) an aluminum case.
 - Petroleum and terpene system solvents; cause the rubber seal material to deteriorate.
 - Xylene; causes the rubber seal material to deteriorate.
 - Acetone; erases the marking.

Solvent resistant capacitors are only suitable for washing using the cleaning conditions prescribed in the catalogs or the product specifications. In particular, ultrasonic cleaning will accelerate damaging capacitors.
- b) Verify the following points when washing capacitors.
 - Monitor conductivity, pH, specific gravity, and the water content of cleaning agents. Contamination adversely affects these characteristics.
 - Be sure not to expose the capacitors under solvent rich conditions or keep capacitors inside a closed container. In addition, please dry the solvent sufficiently on the PC board and the capacitor with an air knife (temperature should be less than the maximum rated category temperature of the capacitor) over 10 minutes. Aluminum electrolytic capacitors can be characteristically and catastrophically damaged by halogen ions, particularly by chlorine ions, though the degree of the damage mainly depends upon the characteristics of the electrolyte and rubber seal material. When halogen ions come into contact with the capacitors, the foil corrodes when voltages applied. This corrosion causes ; extremely high leakage current, which causes in line with, venting, and an open circuit. Global environmental warnings (Greenhouse effects and other environmental destruction by depletion of the ozone layer), new types of cleaning agents have been developed and commercialized as substitutes for CFC-113,1,1,2-trichloroethylene and 1,1,1-trichloroethylene. The following are recommended as cleaning conditions for some of new cleaning agents.

-Higher alcohol system cleaning agents

Recommended cleaning agents:

Pine Alpha ST-100S (Arakawa Chemical)

Clean Through 750H, 750K, 750L, and 710M (Kao)

Technocare FRW-14,15,16,17 (Momentive performance materials)

Cleaning conditions:

Using these cleaning agents capacitors are capable of withstanding immersion or ultrasonic cleaning for 10 minutes at a maximum liquid temperature of 60°C . Find optimum condition for washing, rinsing, and drying. Be sure not to rub the marking off the capacitor by contacting any other components or the PC board. Note that shower cleaning adversely affects the markings on the sleeve.

-Non-Halogenated Solvent Cleaning

AK225AES (Asahi Glass)

Cleaning conditions:

Solvent resistant capacitors are capable of withstanding any one of immersion, ultrasonic or vapor cleaning for 5 minutes; exception is 2 minutes max. for KRE, and KRE-BP series capacitors and 3 minutes for SRM series capacitors. However, from a view of the global environmental problems, these types of solvent will be banned in near future. We would recommended not using them as much as possible.

Isopropyl alcohol cleaning agents

IPA (Isopropyl Alcohol) is one of the most acceptable cleaning agents; it is necessary to maintain a flux content in the cleaning liquid at a maximum limit of 2 Wt%.

[5] Precautions for using adhesives and coating materials

- a) Do not use any adhesive and coating materials containing halogenated solvent.
- b) Verify the following before using adhesive and coating material.
 - Remove flux and dust leftover between the rubber seal and the PC board before applying adhesive or coating materials to the capacitor.
 - Dry and remove any residual cleaning agents before applying adhesive and coating materials to the capacitors. Do not cover over the whole surface of the rubber seal with the adhesive or coating materials.
 - For permissible heat conditions for curing adhesives or coating materials, follow the instructions in the catalogs or the product specifications of the capacitors.
 - Covering over the whole surface of the capacitor rubber seal with resin may result in a hazardous condition because the inside pressure cannot release completely. Also, a large amount of halogen ions in resins will cause the capacitors to fail because the halogen ions penetrate into the rubber seal and the inside of the capacitor.
- c) Some coating materials, it cannot be implemented to the capacitor.
Please note that loose luster and whitening on the surface of the outer sleeve might be caused according to the kind of solvents used for mounting adhesives and coating agents.

[6] Fumigation

In many cases when exporting or importing electronic devices, such as capacitors, wooden packaging is used. In order to control insects, many times, it becomes necessary to fumigate the shipments. Precautions during "Fumigation" using halogenated chemical such as Methyl Bromide must be taken. Halogen gas can penetrate packaging materials used, such as, cardboard boxes and vinyl bags. Penetration of the halogenide gas can cause corrosion of Electrolytic capacitors.

The Operation of Devices

- a) Do not touch terminals of capacitor directly with bare hands.
- b) Do not short-circuit the terminal of a capacitor by letting it come into contact with any conductive object. Also, do not spill electric-conductive liquid such as acid or alkaline solution over the capacitor.
- c) Do not use capacitors in circumstance where they would be subject to exposure to the following materials exist or expose.
 - Oil, water, salty water or damp location.
 - Direct sunlight.
 - Toxic gases such as hydrogen sulfide, sulfurous acid, nitrous acid, chlorine or its compounds, and ammonium.
 - Ozone, ultraviolet rays or radiation.
 - Severe vibration or mechanical shock conditions beyond the limits prescribed in the catalogs or product specification.

Maintenance Inspection

- a) Make periodic inspections of capacitors that have been used in industrial applications. Before inspection, turn off the power supply and carefully discharge the electricity in the capacitors. Verify the polarity when measuring the capacitors with a volt-ohm meter. Also, do not apply any mechanical stress to the terminals of the capacitors.
- b) The following items should be checked during the periodic inspections.
 - Significant damage in appearance : venting and electrolyte leakage.
 - Electrical characteristics: leakage current, capacitance, $\tan \delta$ and other characteristics prescribed in the catalogs or product specifications.We recommend replacing the capacitors if the parts are out of specification.

In Case of Venting

- a) If a non-solid aluminum electrolytic capacitor expels gas when venting, it will discharge odors or smoke, or burn in the case of a short-circuit failure. Immediately turn off or unplug the main power supply of the device.
- b) When venting, a non-solid aluminum electrolytic capacitor blows out gas with a temperature of over 100°C. (A solid aluminum electrolytic capacitor discharges decomposition gas or burning gas while the outer resin case is burning.) The gas which comes out from the pressure vent of a capacitor, it is not smoke by flammable. This is the vaporized electrolyte. Never expose the face close to a venting capacitor. If your eyes should inadvertently become exposed to the spouting gas or you inhale it, immediately flush the open eyes with large amounts of water and gargle with water respectively. If electrolyte is on the skin, wash the electrolyte away from the skin with soap and plenty of water. Do not lick the electrolyte of non-solid aluminum electrolytic capacitors.

Storage

We recommend the following conditions for storage.

- a) Do not store capacitors at a high temperature or in high humidity. Store the capacitors indoors at a temperature of 5 to 35°C and a humidity of less than 75% RH.
- b) Keep capacitors in the original package.

- c) Store the capacitors in places free from water, oil or salt water.
- d) Store the capacitors in places free from toxic gasses (hydrogen sulfide, sulfurous acid, chlorine, ammonium, etc.)
- e) Store the capacitors in places free from acidic and alkaline solvents.
- f) Store the capacitors in places free from ozone, ultraviolet rays or radiation.
- g) Store the capacitor in place free vibrations and mechanical shocks.
- h) It is not applied to a regulation of JEDEC J-STD-020(Rev.C).

Disposal

Please consult with a local industrial waste disposal specialist when disposing of aluminum electrolytic capacitors.

Precautions and guidelines

For more details of precautions and guidelines for aluminum electrolytic capacitors, please refer to Engineering Bulletin No. 634A.

Regarding compliance for EU REACH Regulation

According to the content of REACH handbook (Guidance on requirements for substances in articles which is published on May 2008), our electronic components are "articles without any intended release". Therefore they are not applicable for "Registration" for EU REACH Regulation Article 7 (1).

Reference: Electrolytic Condenser Investigation Society

"Study of REACH Regulation in EU about Electrolytic Capacitor" (publicized on 13 March 2008)